



# OWNER'S MANUAL

**JSS™**

**MODEL JSS120A60, JSS230A50I**



Copyright SawStop, LLC  
All Rights Reserved.

Rev F - January 2025

Updates of this manual may be available at [www.sawstop.com](http://www.sawstop.com)

SawStop, the SawStop blade logo, and the configuration of this product are either registered trademarks or trademarks of SawStop, LLC. Software copyright by SawStop, LLC. All rights reserved. Protected by one or more of the following U.S. patents: 6857345, 6997090, 7024975, 7055417, 7098800, 7100483, 7197969, 7210383, 7225712, 7228772, 7284467, 7308843, 7350445, 7472634, 7481140, 7525055, 7536238, 7600455, 7610836, 7640835, 7661343, 7681479, 7707918, 7707920, 7788999, 7832314, 7895927, 7921754, 7958806, 7971613, 7991503, 7997176, 8006595, 8011279, 8051759, 8061245, 8079292, 8087438, 8122807, 8151675, 8191450, 8196499, 8266997, 8291797, 8371196, 8402869, 8408106, 8438958, 8469067, 8489223, 8490527, 8498732, 8505424, 8522655, 8646369, 9038515, 9522476, 9555491, 9623498, 9757871, 9724840, 9844891, 9908189, 9919369, 9925683, 9969014, 10022811, 10052786, 10071499, 10092968, 10118308. Also protected by Australia patents 785422, 2007201914, and 2011236043, Canada patents 2389596, 2660280, and 2762156, China patent ZL00816099.6, Europe patent EP 1234285 B1, Japan patent 5043267, Mexico patent 250009, and Taiwan patent 143466. Additional U.S. and foreign patents pending.

# TABLE OF CONTENTS



<b>How to Get Help</b> .....	6
<b>Warranty</b> .....	7
<b>Safety Warnings</b> .....	8
<b>No Warranty of Safety</b> .....	8
<b>Safety</b> .....	8
<b>Wood Dust</b> .....	8
<b>General Power Tool Safety Warnings</b> .....	8
<b>Safety Instructions for Table Saws</b> .....	10
<b>Additional Safety Warnings</b> .....	14
<b>Warning Labels</b> .....	17
<b>The SawStop Safety System</b> .....	18
<b>Get to Know Your Saw</b> .....	22
<b>Overview</b> .....	22
Power Controls .....	22
<b>Location of Accessories</b> .....	23
Accessory Drawer .....	23
Location of Storage Drawer Accessories .....	23
Fence, Power Cord, and Push Stick Storage .....	24
<b>Use Your Saw</b> .....	25
<b>Mobile Cart</b> .....	25
Setup and Transport .....	25
Remove/Install Mobile Cart .....	27
<b>Remove/Install Table Insert</b> .....	28
Remove Table Insert .....	28
Install Table Insert .....	28
<b>Remove/Install Blade</b> .....	29
<b>Blade Guard and Spreader</b> .....	30
How to Use Blade Guard .....	30
Remove/Install Blade Guard .....	31
Anti-Kickback Pawls .....	32
<b>Riving Knife</b> .....	33
<b>Brake Cartridge</b> .....	34
How to Change Brake .....	34
How to Replace Activated Brake Cartridge .....	35
<b>Attach Dust Collection</b> .....	37
<b>Set Blade Elevation and Tilt</b> .....	38
<b>Rip Fence and Extension Table</b> .....	40

Low Fence . . . . .	43
Support Shelf . . . . .	44
<b>Operation . . . . .</b>	<b>45</b>
About Power Controls . . . . .	45
Status Lights & Codes . . . . .	45
Normal Mode . . . . .	47
Start in Normal Mode . . . . .	47
Non-Conductive Materials . . . . .	47
Stop in Normal Mode . . . . .	48
Bypass Mode . . . . .	49
How to Disable Your Saw . . . . .	49
Conductive Materials . . . . .	49
Start in Bypass Mode . . . . .	50
Bypass Mode . . . . .	50
Stop in Bypass Mode . . . . .	51
How Disable Bypass Mode . . . . .	51
How to Test Material Conductivity . . . . .	51
<b>Care for &amp; Adjust Your Saw . . . . .</b>	<b>52</b>
<b>Maintenance . . . . .</b>	<b>52</b>
User-Replaceable Parts . . . . .	52
All Parts . . . . .	52
Power Cord . . . . .	52
Blade Guard . . . . .	53
Cabinet . . . . .	53
<b>Make Adjustments . . . . .</b>	<b>54</b>
Adjust Table Insert . . . . .	54
Vertical Movement . . . . .	54
Align to the Table Top Surface . . . . .	54
Adjust Fence . . . . .	55
Clamping Force . . . . .	55
Alignment . . . . .	55
Adjust Indicator Lens . . . . .	56
Align Blade to Table . . . . .	57
Align Extension Table . . . . .	59
<b>Troubleshooting . . . . .</b>	<b>61</b>
<b>Reference . . . . .</b>	<b>64</b>
<b>Dimensions . . . . .</b>	<b>64</b>
<b>Electrical Connection . . . . .</b>	<b>65</b>
JSS-120A60 . . . . .	66
JSS-230A50I . . . . .	66
<b>Cut Slot in Zero-Clearance Insert . . . . .</b>	<b>67</b>

<b>Cutting Operations</b> .....	69
Saw Blade .....	69
Material Requirements .....	70
Auxiliary Fence and Push Block .....	71
Featherboard .....	71
<b>Miter Gauge</b> .....	72
Adjust Miter Gauge .....	72
Miter Gauge Extension .....	73
<b>Cut Types</b> .....	74
Rip Cut .....	75
Non-Through Cut .....	76
Cross Cut .....	77
Dado Cut .....	78
Groove Cut .....	79
Rabbet Cut .....	80
Grooving Cut .....	81
Plunge Cut .....	82
Other Cut Types .....	83
Resawing and Plowing (Cove Cutting) .....	83
<b>Exploded Views and Parts Lists</b> .....	84
Table and Fence .....	84
Cabinet Assembly .....	86
Internal Assembly .....	88
Arbor Assembly .....	90
Blade Guard and Miter Gauge Assembly .....	90
Mobile Cart Assembly .....	92
Literature and Tools .....	93
<b>Templates</b> .....	94
Push Stick .....	94
Featherboard .....	95
Auxiliary Fence .....	96
Push Block .....	97



## Have Questions? Contact Us:



Main	503.570.3200 or 1.866.729.7867	info@sawstop.com
Technical Support (Service)	503.582.9934	service@sawstop.com
Parts	503.486.6923	parts@sawstop.com
Sales	503.595.2665	sales@sawstop.com



SawStop, LLC  
11555 SW Myslony Street, Tualatin, Oregon 97062 USA  
[www.sawstop.com](http://www.sawstop.com)



SawStop warrants to the original retail purchaser of a new Jobsite Saw Pro from an authorized SawStop distributor that the saw will be free from defects in material and workmanship for TWO YEARS from the date of purchase.

SawStop warrants to the original retail purchaser of a refurbished Jobsite Saw Pro from an authorized SawStop distributor that the saw will be free from defects in material and workmanship for ONE YEAR from the date of purchase.

This warranty does not apply to defects arising from misuse, abuse, negligence, accidents, normal wear-and-tear, unauthorized repair or alteration, or lack of maintenance. This warranty is void if the saw or any portion of the Jobsite Saw Pro is modified without the prior written permission of SawStop, LLC, or if the Jobsite Saw Pro is located or has been operated outside of the country where the authorized SawStop distributor from whom the saw was purchased resides.

Please contact SawStop to take advantage of this warranty. If SawStop determines the Jobsite Saw Pro is defective in material or workmanship, and not due to misuse, abuse, negligence, accidents, normal wear-and-tear, unauthorized repair or alteration, or lack of maintenance, then SawStop will, at its expense, and upon proof of purchase, send replacement parts to the original retail purchaser necessary to cure the defect.

SawStop disclaims any and all other express or implied warranties, including merchantability and fitness for a particular purpose. SawStop shall not be liable for death, injuries to persons or property, or incidental, consequential, contingent or special damages arising from the use of the Jobsite Saw Pro.

This warranty gives you specific legal rights. You may have other rights, which vary from state to state.



## NO WARRANTY OF SAFETY

It is important to understand that the braking technology in SawStop table saws does not prevent contact with the blade—it minimizes the effect of the contact. If you do contact the blade, the braking technology will stop the blade, and in most cases there will be no injury or only a small nick. However, you may incur a serious injury on a SawStop saw depending on factors such as the speed and direction your hand is moving when it contacts the blade and the type of blade you are using. Also, if you decide to use the saw in Bypass Mode ([see page 49](#)), the safety system will be disabled and will not activate in the event you contact the spinning blade.

## SAFETY

A table saw is a dangerous tool and there are hazards inherent with using this saw. Some of these hazards are discussed in the following sections. Use common sense when operating the saw and use the saw only as instructed. ***You are responsible for your own safety!***

## WOOD DUST

 This product can expose you to chemicals including wood dust, which is known to the State of California to cause cancer. This exposure can come from drilling, sawing, sanding or machining wood products. For more information go to [www.P65Warnings.ca.gov/wood](http://www.P65Warnings.ca.gov/wood). In addition, some types of dust created by sawing, power sanding, grinding, drilling, and other construction activities also contain chemicals known to cause cancer, birth defects or other reproductive harm. Some examples of these chemicals are lead from lead-based paints, crystalline silica from bricks, cement, and other masonry products, and arsenic and chromium from chemically treated lumber. In addition, wood dust has been listed as a known human carcinogen by the U.S. government. The risk from exposure to these chemicals and to dust varies depending on how often you do this type of work. To reduce your exposure, work in a well ventilated area and work with approved safety equipment including dust masks or respirators designed to filter out such dust and chemicals.

## GENERAL POWER TOOL SAFETY WARNINGS

 **WARNING** Read all safety warnings, instructions, illustrations and specifications provided with this power tool. *Failure to follow all instructions listed below may result in electric shock, fire and/or serious injury.*

 **General Power Tool Safety Warnings - Work Area Safety**

- **Keep work area clean and well lit.** *Cluttered or dark areas invite accidents.*
- **Do not operate power tools in explosive atmospheres, such as in the presence of flammable liquids, gases or dust.** *Power tools create sparks which may ignite the dust or fumes.*
- **Keep children and bystanders away while operating a power tool.** *Distractions can cause you to lose control.*



## General Power Tool Safety Warnings - Electrical Safety

- **Power tool plugs must match the outlet. Never modify the plug in any way. Do not use any adapter plugs with earthed (grounded) power tools.** *Unmodified plugs and matching outlets will reduce risk of electric shock.*
- **Avoid body contact with earthed or grounded surfaces, such as pipes, radiators, ranges and refrigerators.** *There is an increased risk of electric shock if your body is earthed or grounded.*
- **Do not expose power tools to rain or wet conditions.** *Water entering a power tool will increase the risk of electric shock.*
- **Do not abuse the cord. Never use the cord for carrying, pulling or unplugging the power tool. Keep cord away from heat, oil, sharp edges or moving parts.** *Damaged or entangled cords increase the risk of electric shock.*
- **When operating a power tool outdoors, use an extension cord suitable for outdoor use.** *Use of a cord suitable for outdoor use reduces the risk of electric shock.*
- **If operating a power tool in a damp location is unavoidable, use a residual current device (RCD) protected supply.** *Use of an RCD reduces the risk of electric shock.*



## General Power Tool Safety Warnings - Personal Safety

- **Stay alert, watch what you are doing and use common sense when operating a power tool. Do not use a power tool while you are tired or under the influence of drugs, alcohol or medication.** *A moment of inattention while operating power tools may result in serious personal injury.*
- **Use personal protective equipment. Always wear eye protection.** *Protective equipment such as a dust mask, non-skid safety shoes, hard hat or hearing protection used for appropriate conditions will reduce personal injuries.*
- **Prevent unintentional starting. Ensure the switch is in the off-position before connecting to power source and/or battery pack, picking up or carrying the tool.** *Carrying power tools with your finger on the switch or energizing power tools that have the switch on invites accidents.*
- **Remove any adjusting key or wrench before turning the power tool on.** *A wrench or a key left attached to a rotating part of the power tool may result in personal injury.*
- **Do not overreach. Keep proper footing and balance at all times.** *This enables better control of the power tool in unexpected situations.*
- **Dress properly. Do not wear loose clothing or jewelry. Keep your hair and clothing away from moving parts.** *Loose clothes, jewelry or long hair can be caught in moving parts.*
- **If devices are provided for the connection of dust extraction and collection facilities, ensure these are connected and properly used.** *Use of dust collection can reduce dust-related hazards.*
- **Do not let familiarity gained from frequent use of tools allow you to become complacent and ignore tool safety principles.** *A careless action can cause severe injury within a fraction of a second.*



## General Power Tool Safety Warnings - Power Tool Use and Care

- **Do not force the power tool. Use the correct power tool for your application.** *The correct power tool will do the job better and safer at the rate for which it was designed.*
- **Do not use the power tool if the switch does not turn it on and off.** *Any power tool that cannot be controlled with the switch is dangerous and must be repaired.*
- **Disconnect the plug from the power source and/or remove the battery pack, if detachable, from the power tool before making any adjustments, changing accessories, or storing power tools.** *Such preventive safety measures reduce the risk of starting the power tool accidentally.*
- **Store idle power tools out of the reach of children and do not allow persons unfamiliar with the power tool or these instructions to operate the power tool.** *Power tools are dangerous in the hands of untrained users.*
- **Maintain power tools and accessories. Check for misalignment or binding of moving parts, breakage of parts and any other condition that may affect the power tool's operation. If damaged, have the power tool repaired before use.** *Many accidents are caused by poorly maintained power tools.*
- **Keep cutting tools sharp and clean.** *Properly maintained cutting tools with sharp cutting edges are less likely to bind and are easier to control.*
- **Use the power tool, accessories and tool bits etc., in accordance with these instructions, taking into account the working conditions and the work to be performed.** *Use of the power tool for operations different from those intended could result in a hazardous situation.*
- **Keep handles and grasping surfaces dry, clean and free from oil and grease.** *Slippery handles and grasping surfaces do not allow for safe handling and control of the tool in unexpected situations.*



## General Power Tool Safety Warnings - Electrical Safety

- **Have your power tool serviced by a qualified repair person using only identical replacement parts.** *This will ensure that the safety of the power tool is maintained.*

# SAFETY INSTRUCTIONS FOR TABLE SAWS



## Guarding-Related Warnings

- **Keep guards in place. Guards must be in working order and be properly mounted.** *A guard that is loose, damaged, or is not functioning correctly must be repaired or replaced.*
- **Always use saw blade guard, riving knife and anti-kickback pawls for every through-cutting operation.** *For through-cutting operations where the saw blade cuts completely through the thickness of the workpiece, the guard and other safety devices help reduce the risk of injury.*

- **Immediately reattach the guarding system after completing an operation (such as rabbeting, Dadoing or re-sawing cuts) which requires removal of the guard, riving knife and/or anti-kickback pawls.** *The guard, riving knife, and anti-kickback pawls help to reduce the risk of injury.*
- **Make sure the saw blade is not contacting the guard, riving knife or the workpiece before the switch is turned on.** *Inadvertent contact of these items with the saw blade could cause a hazardous condition.*
- **Adjust the riving knife as described in this instruction manual.** *Incorrect spacing, positioning and alignment can make the riving knife ineffective in reducing the likelihood of kickback.*
- **For the riving knife and anti-kickback pawls to work, they must be engaged in the workpiece.** *The riving knife and anti-kickback device are ineffective when cutting workpieces that are too short to be engaged with the riving knife and anti-kickback device. Under these conditions a kickback cannot be prevented by the riving knife and anti-kickback pawls.*
- **Use the appropriate saw blade for the riving knife.** *For the riving knife to function properly, the saw blade diameter must match the appropriate riving knife and the body of the saw blade must be thinner than the thickness of the riving knife and the cutting width of the saw blade must be wider than the thickness of the riving knife.*



### Cutting Procedures Warnings

- **⚠ DANGER: Never place your fingers or hands in the vicinity or in line with the saw blade.** *A moment of inattention or a slip could direct your hand towards the saw blade and result in serious personal injury.*
- **Feed the workpiece into the saw blade only against the direction of rotation.** *Feeding the workpiece in the same direction that the saw blade is rotating above the table may result in the workpiece, and your hand, being pulled into the saw blade.*
- **Never use the miter gauge to feed the workpiece when ripping and do not use the rip fence as a length stop when cross cutting with the miter gauge.** *Guiding the workpiece with the rip fence and the miter gauge at the same time increases the likelihood of saw blade binding and kickback.*
- **When ripping, always apply the workpiece feeding force between the fence and the saw blade.** *Use a push stick when the distance between the fence and the saw blade is less than 150 mm, and use a push block when this distance is less than 50 mm. Work helping devices will keep your hand at a safe distance from the saw blade.*
- **Use only the push stick provided by the manufacturer or constructed in accordance with the instructions.** *This push stick provides sufficient distance of the hand from the saw blade.*
- **Never use a damaged or cut push stick.** *A damaged push stick may break causing your hand to slip into the saw blade.*
- **Do not perform any operation ‘freehand.’ Always use either the rip fence or the miter gauge to position and guide the workpiece.** *‘Freehand’ means using your hands to support or guide the workpiece, in lieu of a rip fence or miter gauge. Freehand sawing leads to misalignment, binding and kickback.*
- **Never reach around or over a rotating saw blade.** *Reaching for a workpiece may lead to*

*accidental contact with the moving saw blade.*

- **Provide auxiliary workpiece support to the rear and/or sides of the saw table for long and/or wide workpieces to keep them level.** *A long and/or wide workpiece has a tendency to pivot on the table's edge, causing loss of control, saw blade binding and kickback.*
- **Feed workpiece at an even pace. Do not bend or twist the workpiece. If jamming occurs, turn the tool off immediately, unplug the tool then clear the jam.** *Jamming the saw blade by the workpiece can cause kickback or stall the motor.*
- **Do not remove pieces of cut-off material while the saw is running.** *The material may become trapped between the fence or inside the saw blade guard and the saw blade pulling your fingers into the saw blade. Turn the saw off and wait until the saw blade stops before removing material.*
- **Use an auxiliary fence in contact with the table top when ripping workpieces less than 2 mm thick.** *A thin workpiece may wedge under the rip fence and create a kickback.*



### **Kickback Causes and Warnings**

Kickback is a sudden reaction of the workpiece due to a pinched, jammed saw blade or misaligned line of cut in the workpiece with respect to the saw blade or when a part of the workpiece binds between the saw blade and the rip fence or other fixed object.

Most frequently during kickback, the workpiece is lifted from the table by the rear portion of the saw blade and is propelled towards the operator.

Kickback is the result of saw misuse and/or incorrect operating procedures or conditions and can be avoided by taking proper precautions as given below.

- **Never stand directly in line with the saw blade. Always position your body on the same side of the saw blade as the fence.** *Kickback may propel the workpiece at high velocity towards anyone standing in front and in line with the saw blade.*
- **Never reach over or in back of the saw blade to pull or to support the workpiece.** *Accidental contact with the saw blade may occur or kickback may drag your fingers into the saw blade.*
- **Never hold and press the workpiece that is being cut off against the rotating saw blade.** *Pressing the workpiece being cut off against the saw blade will create a binding condition and kickback.*
- **Align the fence to be parallel with the saw blade.** *A misaligned fence will pinch the workpiece against the saw blade and create kickback.*
- **Use a featherboard to guide the workpiece against the table and fence when making non-through cuts such as rabbeting, Dadoing or re-sawing cuts.** *A featherboard helps to control the workpiece in the event of a kickback.*
- **Use extra caution when making a cut into blind areas of assembled workpieces.** *The protruding saw blade may cut objects that can cause kickback.*
- **Support large panels to minimize the risk of saw blade pinching and kickback.** *Large panels tend to sag under their own weight. Support(s) must be placed under all portions of the panel overhanging the table top.*

- **Use extra caution when cutting a workpiece that is twisted, knotted, warped or does not have a straight edge to guide it with a miter gauge or along the fence.** *A warped, knotted, or twisted workpiece is unstable and causes misalignment of the kerf with the saw blade, binding and kickback.*
- **Never cut more than one workpiece, stacked vertically or horizontally.** *The saw blade could pick up one or more pieces and cause kickback.*
- **When restarting the saw with the saw blade in the workpiece, center the saw blade in the kerf so that the saw teeth are not engaged in the material.** *If the saw blade binds, it may lift up the workpiece and cause kickback when the saw is restarted.*
- **Keep saw blades clean, sharp, and with sufficient set. Never use warped saw blades or saw blades with cracked or broken teeth.** *Sharp and properly set saw blades minimize binding, stalling and kickback.*



### Table Saw Operating Procedures Warnings

- **Turn off the table saw and disconnect the power cord when removing the table insert, changing the saw blade or making adjustments to the riving knife, anti-kickback device or saw blade guard, and when the machine is left unattended.** *Precautionary measures will avoid accidents.*
- **Never leave the table saw running unattended. Turn it off and don't leave the tool until it comes to a complete stop.** *An unattended running saw is an uncontrolled hazard.*
- **Locate the table saw in a well-lit and level area where you can maintain good footing and balance. It should be installed in an area that provides enough room to easily handle the size of your workpiece.** *Cramped, dark areas, and uneven slippery floors invite accidents.*
- **Frequently clean and remove sawdust from under the saw table and/or the dust collection device.** *Accumulated sawdust is combustible and may self-ignite.*
- **The table saw must be secured.** *A table saw that is not properly secured may move or tip over.*
- **Remove tools, wood scraps, etc., from the table before the table saw is turned on.** *Distraction or a potential jam can be dangerous.*
- **Always use saw blades with correct size and shape (diamond versus round) of arbor holes.** *Saw blades that do not match the mounting hardware of the saw will run off-center, causing loss of control.*
- **Never use damaged or incorrect saw blade mounting means such as flanges, saw blade washers, bolts or nuts.** *These mounting means were specially designed for your saw, for safe operation and optimum performance.*
- **Never stand on the table saw, do not use it as a stepping stool.** *Serious injury could occur if the tool is tipped or if the cutting tool is accidentally contacted.*
- **Make sure that the saw blade is installed to rotate in the proper direction. Do not use grinding wheels, wire brushes, or abrasive wheels on a table saw.** *Improper saw blade installation or use of accessories not recommended may cause serious injury.*

## ADDITIONAL SAFETY WARNINGS

- 1) Read and understand this owner's manual and all safety warnings before operating this saw. Failure to follow instructions or heed warnings may result in electric shock, fire, serious personal injury or property damage. Save these instructions and refer to them whenever necessary.
- 2) This saw must be connected to a grounded wiring system or to a system having an equipment-grounding conductor (see page 65). In the event of a malfunction or breakdown, grounding provides a path of least resistance for electric current to reduce the risk of electric shock. This saw is equipped with an electric cord having an equipment-grounding conductor and a grounding plug. The plug must be plugged into a matching outlet that is properly installed and grounded in accordance with all local codes and ordinances. Do not modify the plug provided - if it will not fit the outlet; have the proper outlet installed by a qualified electrician. Improper connection of the equipment-grounding conductor can result in a risk of electric shock and/or malfunction. If repair or replacement of the electric cord or plug is necessary, do not connect the equipment-grounding conductor to a live terminal.

Check with a qualified electrician or service personnel if the grounding instructions are not completely understood or if in doubt as to whether the saw is properly grounded. Use only 3-wire extension cords that have 3-prong grounding plugs and 3-pole receptacles that accept the saw's plug. Repair or replace a damaged or worn cord immediately.

- 3) Use the proper extension cord. Make sure your extension cord is in good condition. When using an extension cord, be sure to use one heavy enough to carry the current your saw will draw. An undersized cord will cause a drop in line voltage resulting in loss of power and overheating. For a cord length of 0 to 25 feet, use a 12 gauge cord. For a cord length of 25 to 50 feet, use a 10 gauge cord. A cord length over 50 feet is not recommended. If in doubt, use the next heavier gauge. The smaller the gauge number the heavier the cord.
- 4) This saw is intended for use on a circuit that has an outlet that looks like the one illustrated later in this manual (see page 65). The saw has a grounding plug that looks like the plug illustrated later in this manual (see page 65). Make sure the saw is connected to an outlet having the same configuration as the plug. An adapter may be used temporarily for a two-prong outlet. The grounding lug or tab on the adapter must be connected to the ground connection on a properly grounded outlet (see page 65). If the saw must be reconnected for use on a different type of electric circuit, the reconnection should be made by qualified service personnel; and after reconnection, the saw should comply with all local codes and ordinances.
- 5) Keep children away from the saw. All visitors should be kept at a safe distance from the work area. Make the workshop or work area kid-proof with padlocks, master switches, or by removing lock-out keys.
- 6) Do not use the saw in dangerous environments. For example, do not use the saw in damp or wet locations or expose it to rain, and keep the work area well-lighted.
- 7) Check to make sure the saw is in proper working order before using the saw. For example, check the alignment of moving parts, look to see whether moving parts are binding or rubbing, check to see whether parts are broken, make sure accessories are properly mounted on the

saw, and check any other conditions that may affect the operation of the saw. A guard or other part that is damaged should be properly repaired or replaced.

- 8) Keep guards in place and in working order.
- 9) Wear eye protection. Always wear safety glasses when using the saw. Everyday eyeglasses are not safety glasses. Also use a face or dust mask if the cutting operation is dusty.
- 10) Wear proper apparel when using the saw. Do not wear loose clothing, gloves, neckties, rings, bracelets, or other jewelry which may get caught in moving parts. Non-slip footwear is recommended. Wear a protective hair covering to contain long hair.
- 11) You must use the rip fence when using this saw for rip cutting. Attempting to use the saw for rip cutting without the rip fence could result in serious personal injury.
- 12) Reduce the risk of unintentional starting. Make sure the power switch is in the OFF position before plugging in the saw.
- 13) Keep hands out of the line of the saw blade. Never reach around or over the saw. Do not overreach or stretch to get something when using the saw. Keep proper footing and balance at all times.
- 14) Never stand on the saw. Serious injury could occur if the saw is tipped or if the cutting tool is unintentionally contacted.
- 15) Feed the work piece into the blade against the direction of rotation of the blade only. Feeding the work piece in the direction of rotation may cause the work to be thrown by the blade and could result in serious personal injury.
- 16) Do not perform any operation freehand. Freehand means not using a fence (for rip cuts) or a miter gauge (for cross-cuts) to guide the work piece as it is being cut. Always maintain firm control over the material being cut.
- 17) Use a blade guard and spreader for every operation for which it can be used, including all through-sawing. Use a push stick or push block when required.
- 18) Secure your work. Use clamps or a vise to hold work when practical. It's safer than using your hand and it frees both hands to operate tool.
- 19) Pay particular attention to instructions on reducing the risk of kickback. Kickback occurs when a work piece contacts the downstream edge of the blade as it is being cut and is propelled back towards the user at high velocity.
- 20) Don't force the tool. It will do the job better and safer at the rate for which it was designed. For example, do not try to cut wood faster than the motor can handle.
- 21) Use the right tool. Do not try to force the saw to do something it was not designed to do. Don't force a tool or attachment to do a job for which it was not designed. Use the right blade for the job.
- 22) Never leave the saw running unattended. Wait until the blade comes to a complete stop and then turn the main power switch to OFF and unplug the power cord when you are finished using the saw.

- 23) Turn the main power switch to OFF and unplug the power cord before servicing the saw and when changing components or accessories such as blades, brake cartridges, and the like.
- 24) Maintain tools with care. Maintain the saw as specified in this manual. Keep tools sharp and clean for best and safest performance. Follow instructions for lubrication and changing accessories.
- 25) Use only recommended accessories with the saw. Consult this manual for recommended accessories. The use of improper accessories may cause risk of injury. When servicing, use only identical replacement parts.
- 26) Keep the top of the saw clean and free from clutter. Cluttered areas invite accidents.
- 27) Devices that emit electrical noise in the range of 400-600 kHz might cause the brake cartridge to activate. Keep such devices away from the saw.

# WARNING LABELS

Warnings are mounted on the left side of the saw, on the cart, and on the blade guard. Some of the warnings on those labels may be additional to the warnings listed in the preceding *Warnings* section. Be sure to read the warning labels before using the saw. Copies of the warning labels are reproduced here:

 <b>WARNING</b>	 <b>ADVERTENCIA</b>	 <b>AVERTISSEMENT</b>
<p>To reduce the risk of injury, user must read instruction manual</p> <ol style="list-style-type: none"> <li>1. WARNING - Wear eye protection.</li> <li>2. WARNING - Always use a properly functioning saw-blade guard, riving knife and anti-kick-back device for every operation for which it can be used, including all through sawing.</li> <li>3. DANGER - Never place your hands in the vicinity or in line with the saw blade.</li> <li>4. WARNING - Use a push-stick or push-block when required.</li> <li>5. WARNING - Know how to reduce risk of kickback.</li> <li>6. WARNING - Do not perform any operation freehand.</li> <li>7. WARNING - Never reach around or over saw blade.</li> <li>8. WARNING - Never stand directly in-line with the saw blade. Always position your body on the same side of the saw blade as the fence</li> <li>9. WARNING - Turn off tool and wait for saw blade to stop before moving workpiece or changing settings.</li> <li>10. Never try to test fire the brake system.</li> <li>11. Do not try to disable the brake system.</li> <li>12. Do not connect the motor directly to a power supply.</li> <li>13. Use the bypass switch only when necessary.</li> <li>14. Do not expose to rain or use in damp locations.</li> <li>15. Do not put your hands inside the cabinet while the blade is spinning.</li> <li>16. Do not unplug or disconnect the saw from electrical power before the blade has stopped spinning.</li> <li>17. Unplug the saw before changing the blade, changing the brake cartridge or servicing.</li> </ol>	<p>Para reducir el riesgo de lesiones, el usuario debe leer el manual de instrucciones</p> <ol style="list-style-type: none"> <li>1. ADVERTENCIA: utilice protección para los ojos.</li> <li>2. ADVERTENCIA: siempre utilice una protección de la hoja de la sierra, una cuchilla separadora y un dispositivo antirretroceso que funcionen adecuadamente en todas las operaciones para las que se puedan utilizar, incluso en todas las operaciones de aserrado de extremo a extremo.</li> <li>3. PELIGRO: nunca coloque las manos cerca ni en la línea de la hoja de la sierra.</li> <li>4. ADVERTENCIA: utilice una barra o un bloque de empuje cuando sea necesario.</li> <li>5. ADVERTENCIA: conozca la forma de reducir el riesgo de retrocesos.</li> <li>6. ADVERTENCIA: no realice ninguna operación a mano.</li> <li>7. ADVERTENCIA: nunca extienda las manos alrededor de la hoja de la sierra ni por encima de ella.</li> <li>8. ADVERTENCIA: nunca se pare directamente en la línea de la hoja de la sierra. Ubíquese siempre con el cuerpo del lado del tope de la hoja de la sierra.</li> <li>9. ADVERTENCIA: apague la herramienta y espere a que la hoja de la sierra se detenga para mover las piezas de trabajo o modificar los ajustes.</li> <li>10. Nunca intente activar el sistema de freno a modo de prueba.</li> <li>11. No intente desarmar el sistema de freno.</li> <li>12. No conecte el motor directamente a una fuente de alimentación.</li> <li>13. Utilice el interruptor de derivación únicamente cuando sea necesario.</li> <li>14. No exponga la herramienta a la lluvia ni la utilice en lugares húmedos.</li> <li>15. No coloque las manos en el interior del gabinete mientras la hoja esté girando.</li> <li>16. No desenchufe ni desconecte la sierra de la corriente eléctrica hasta que la hoja deje de girar.</li> <li>17. Desconecte la sierra antes de cambiar la hoja, el cartucho de freno o realizar tareas de mantenimiento.</li> </ol>	<p>Afin de réduire le risque de blessure, l'utilisateur doit lire le manuel d'utilisation.</p> <ol style="list-style-type: none"> <li>1. AVERTISSEMENT - Portez des lunettes de protection.</li> <li>2. AVERTISSEMENT - Utilisez toujours un protège-lame de scie, un couteau séparateur et un dispositif anti-recul en bon état pour chaque opération pour laquelle ils peuvent être utilisés, y compris tout au long du sciage.</li> <li>3. DANGER - Ne placez jamais vos mains à proximité ou sur la trajectoire de la lame de scie.</li> <li>4. AVERTISSEMENT - Utilisez un bâton-poussoir ou un bloc-poussoir au besoin.</li> <li>5. AVERTISSEMENT - Vous devez savoir comment réduire le risque de recul.</li> <li>6. AVERTISSEMENT - N'effectuez aucune opération à main nue.</li> <li>7. AVERTISSEMENT - N'envoyez jamais la main autour ou au-dessus de la lame de scie.</li> <li>8. AVERTISSEMENT - Ne vous tenez jamais directement sur la trajectoire de la lame de scie. Votre corps doit toujours être du même côté de la lame de scie que la grille.</li> <li>9. AVERTISSEMENT - Éteignez l'outil et attendez que la lame de scie s'arrête avant de déplacer la pièce ou de changer les réglages.</li> <li>10. N'essayez jamais de tester le système de freinage.</li> <li>11. N'essayez pas de désactiver le système de freinage.</li> <li>12. Ne raccordez pas le moteur directement à une alimentation électrique.</li> <li>13. N'utilisez le commutateur de dérivation que lorsque cela est nécessaire.</li> <li>14. N'exposez pas l'appareil à la pluie et ne l'utilisez pas dans des endroits humides.</li> <li>15. Ne mettez pas vos mains à l'intérieur de l'armoire lorsque la lame tourne.</li> <li>16. Évitez de débrancher ou déconnecter la scie avant que la lame n'ait cessé de tourner.</li> <li>17. Débranchez la scie avant de changer la lame, de changer la cartouche de frein ou d'effectuer une opération d'entretien.</li> </ol>
<p> <b>WARNING:</b></p> <p>This product can expose you to chemicals including wood dust, which is known to the State of California to cause cancer. For more information, go to <a href="http://www.P65Warnings.ca.gov">www.P65Warnings.ca.gov</a>.</p>	<p> <b>ADVERTENCIA:</b></p> <p>Este producto lo puede exponer a productos químicos, como polvo de madera, identificados por el Estado de California como causantes de cáncer. Para obtener más información, visite <a href="http://www.P65Warnings.ca.gov">www.P65Warnings.ca.gov</a>.</p>	<p> <b>AVERTISSEMENT:</b></p> <p>Cet appareil peut vous exposer à des produits chimiques, y compris la poussière de bois reconnue par l'État de Californie comme cancérigène. Pour plus d'informations, rendez-vous à l'adresse <a href="http://www.P65Warnings.ca.gov">www.P65Warnings.ca.gov</a>.</p>

 **WARNING**

1. Use the blade guard and spreader for every operation for which it can be used.
2. Use the riving knife for non-through sawing.
3. Keep hands away from the saw blade. Use a push-stick when required.

 **WARNING:**

This product can expose you to chemicals including wood dust, which is known to the State of California to cause cancer. For more information, go to [www.P65Warnings.ca.gov](http://www.P65Warnings.ca.gov).

 **WARNING**

1. Always use saw and mobile cart on a solid level surface.
2. Unplug and store power cord before moving saw.
3. Ensure lock bar fully engages lock pin before using saw, moving it, or storing it in upright position.
4. Keep fingers away from all moving parts while operating mobile cart.

# THE SAWSTOP SAFETY SYSTEM



The Jobsite Saw Pro is equipped with the SawStop safety system. This revolutionary technology was developed to reduce the potential for a serious injury in the event of accidental contact with the saw blade.

The SawStop safety system includes two components, an electronic detection unit and a fast-acting brake. The electronic detection unit detects when a person contacts the blade. A small electrical signal is induced onto the blade by electrodes placed around the arbor. Although this low voltage, high frequency signal is too small to feel, it can be measured by the detection system. When human skin comes into contact with the blade (or arbor), a portion of the signal is absorbed by the body due to the inherent electrical capacitance of the human body. As a result, the signal on the blade gets smaller and the detection unit recognizes this as contact.

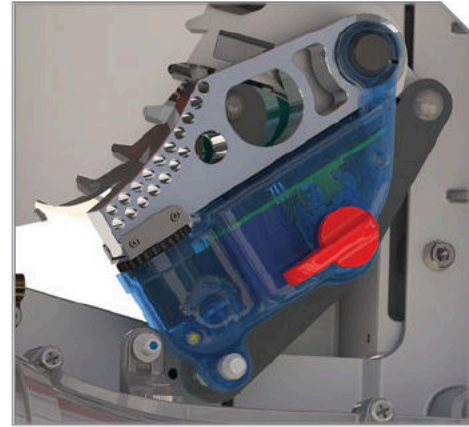

Wood and other non-conductive materials such as plastic, foam, cardboard, Corian, melamine, etc., do not cause a drop in the signal because those materials do not absorb the signal on the blade. Conductive materials such as aluminum and other metals, carbon fiber materials, mirrored acrylic, carbon-filled materials, etc., will typically cause the brake to activate. If you need to cut these conductive materials, the safety system can be placed in “Bypass Mode” to temporarily disable the brake. (see page 50).

The fast-acting brake includes a small fuse that holds a strong spring in compression. If the electronic detection unit detects contact while the blade is spinning (including during coast down), the fuse is burned by a surge of electric current. The spring then pushes an aluminum pawl into the teeth of the spinning blade. The teeth cut into the pawl, stopping the blade. The total time between the detection of contact and stopping the blade is just a few milliseconds. If the brake is activated while the blade is at or near full speed, the blade will also quickly retract below the table. The system will not activate the brake when the blade is stopped—even if you spin the blade by hand. This allows you to touch or change the blade when the motor is off just as with ordinary table saws. However, for safety, always turn the main power switch to OFF and unplug the power cord when changing the blade.

The SawStop safety system is active whenever the main power is on. The safety system continuously performs many different self-checks to ensure that the components of the system are operating properly. If any problems are detected, the safety system will disable the motor and display a system status code to help you identify and correct the problem (see page 45). If the problem is detected while the motor is spinning, the motor will be shut off. The safety system will not allow the motor to start, even in Bypass Mode, as long as a problem is detected.

The electronic detection unit and fast-acting brake are contained in the “brake cartridge,” which is positioned under the table and just behind the blade, as shown above. The brake cartridge must be correctly installed before the motor can be started (see page 34). In the event that the brake is activated, a new brake cartridge must be installed before the saw can be used again.

The SawStop safety system does not interfere with your use of the saw. You can still make all the cuts ([see page 74](#)) that you can with ordinary saws, including 0° to 45° bevels, non-through cuts, and Dado cuts (with the optional Dado brake cartridge and the optional Dado table insert).

Your SawStop saw operates differently than ordinary table saws, and there are a few important points to keep in mind as you use the saw.

- 1) Do not rely on the SawStop safety system to protect against unsafe operation. Although the system is designed to react and stop the blade very quickly in the event of accidental contact, it cannot react until contact is detected. This means that you may receive at least a minor injury even with the SawStop safety system. Therefore, always use safe operating practices, and use the blade guard, push stick and other safety devices whenever possible. The SawStop safety system, like the airbag in a car, should be considered as a last measure to minimize injury when all other safety practices and devices have failed to prevent an accident.
- 2) In the event of contact, the blade will be stopped in about 3–5 milliseconds (coarse-toothed blades stop more quickly than fine-toothed blades such as plywood blades). Therefore, the seriousness of the injury incurred will depend on the speed at which a person's hand or other body part is moving toward the blade. For example, if a person's hand is moving toward the blade at 1 ft./sec., then the depth of the cut will be approximately 1/16 inch (1 ft./sec.\* 0.005 sec. = 0.005 ft. or 1/16 inch). At faster speeds, the cut will be proportionally deeper. Therefore, it is possible to be seriously injured even with the SawStop safety system.
- 3) Do not operate the saw in Bypass Mode unless you are cutting electrically conductive material. ([see page 49](#)) When Bypass Mode is engaged, the SawStop safety system will not activate the brake if contact is detected and a serious injury could result if you contact the blade.
- 4) The motor cannot be started without a blade installed. Since the safety system disables the motor if the blade is spaced too far from the brake, a missing blade will be detected as a blade-to-brake spacing error and the motor will be disabled.

5) Blades:

You can use any standard 10 inch saw blade or 8 inch Dado set with your SawStop saw ([see page 70](#)), although the following precautions should be observed:

- f) Never attempt to use a blade other than a single 10 inch blade with the standard SawStop brake cartridge. Never attempt to use a Dado set or blade other than an 8 inch Dado set with the SawStop Dado cartridge. The use of smaller diameter blades with a brake cartridge designed for larger blades could result in a serious injury because the brake cannot be positioned correctly to stop the smaller blades.
- g) Never stack Dado blades thicker than 13/16 inch ([see page 70](#)). The 8 inch Dado brake cartridge is not designed to stop Dado stacks thicker than 13/16 inch.
- h) Do not use molding heads. The use of molding heads could result in a serious injury because neither the standard brake cartridge nor the Dado brake cartridge is designed to stop a molding

head.

- i) Never use a blade with damaged or missing teeth as this can result in a more serious injury or a false activation of the brake. Blades with variable spacing between teeth are compatible with the SawStop safety system, however you must ensure the brake is positioned correctly by rotating the blade at least one full revolution to be certain that none of the teeth touch the brake.
  - j) Never install the blade backwards. The brake might not stop a blade that is installed backwards.
  - k) Do not use saw blades or Dado sets that have a lacquer or other coating on the teeth. These coatings are non-conductive and therefore can reduce the speed at which the system detects contact. In other words, a coated tooth must cut slightly deeper into the skin for contact to be detected, resulting in a somewhat more serious injury. Used blades that originally had a coating are OK to use since the coating is worn away within a few uses. However, SawStop recommends that you examine each tooth on such blades to confirm that no coating remains.
  - l) Blades with depth-limiting shoulders may take longer to stop in the event of an accident than standard blades, and you could receive a more serious injury. Therefore, SawStop recommends using blades **without** depth-limiting shoulders.
  - m) The SawStop safety system is designed for use with standard 10 inch blades with kerfs from 3/32 inch to 3/16 inch. Blades with kerfs much thinner than 3/32 inch should not be used because those blades might not be strong enough to withstand the force applied by the brake when it activates. As a result, those blades might deform and stop more slowly in the event of an accident, resulting in a more serious injury. Blades with kerfs much thicker than 3/16 inch are heavier than standard 1/8 inch kerf blades, and should not be used because they may stop more slowly than standard blades in the event of an accident, resulting in a more serious injury. Similarly, stacks of two or more 10 inch blades should **never** be used on your SawStop saw as the combined weight of the blades may be too heavy to stop quickly. If you need to use a blade with a kerf thicker than 3/16 inch, use an 8 inch Dado set with the optional Sawstop 8 inch Dado brake cartridge.
  - n) Do not use non-conductive blades, including abrasive blades, blades with plastic hubs, or blades that have non-conductive teeth. The safety system cannot induce the electrical signal onto a non-conductive blade, and blades with non-conductive teeth may prevent the system from detecting contact. Only standard steel blades with either steel or carbide teeth should be used.
- 6) Do not use table inserts, guards, fences or other devices which have metal parts that may come into contact with the blade. Any metal part that contacts the blade may cause the brake to activate. All SawStop accessories are specifically designed to prevent metal contact with the blade.
- 7) Wet, pressure-treated wood may cause the brake to activate. The chemicals used to pressure treat wood often contain large amounts of copper, which is conductive. When pressure-treated wood is wet, the combination of copper and water substantially increases the conductivity of the wood. (see page 49) Therefore, allow wet pressure-treated wood to fully dry before cutting. Typically, the wood will be sufficiently dry if left unstacked in a dry location for 24 hours. If you must cut wet pressure-treated wood, you can make several cuts in the wettest piece(s) using the Bypass Mode to test whether the

wood is too wet. See the instructions on starting the saw in Bypass Mode ([see page 50](#)) and how to test the conductivity of a material ([see page 51](#)). If the test indicates the wood is too wet to cut with the safety system active, you must either allow the wood to dry or make the remaining cuts in Bypass Mode.

- 8) Do not replace the arbor belt with a non-SawStop belt. The SawStop arbor belt is custom designed to dissipate static electricity that may build up on the spinning blade which could cause an unintended activation of the brake.
- 9) Never touch the arbor, arbor pulley, arbor nut or arbor washer when the blade is spinning because you may receive a serious injury. These parts are all electrically coupled to the blade and the brake will activate if contact with these parts is detected.
- 10) Never reach under the blade while it is spinning. In the event the brake is activated, the retraction of the blade may cause a serious injury if you contact the bottom of the blade.
- 11) Do not remove the dust shroud because a large portion of the blade will be exposed. If you contact the blade under the table, the blade may retract toward you and cause a severe injury.
- 12) Do not unplug or disconnect the saw from electrical power before the blade has stopped spinning. If the power is interrupted while the blade is moving, the safety system will not be active and therefore the brake will not activate in the event of accidental contact. You may receive a serious injury if you contact the spinning blade while the electrical power has been interrupted.
- 13) Never attempt to disable the SawStop safety system or modify the electrical wiring of the saw in any way. Any change or modification or disablement of the safety system or other wiring could result in a serious injury and will void all warranties.
- 14) Never attempt to repair, adjust, modify or otherwise service a brake cartridge. There are no user-serviceable parts inside the brake cartridge. The brake cartridge is permanently sealed against dust and other contaminants. Destruction, removal, or alteration of this seal voids all warranties.



## OVERVIEW

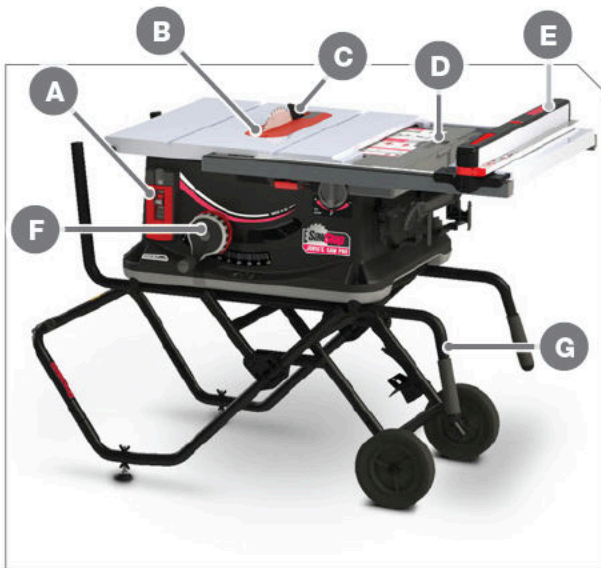

- A. Power Controls
- B. Table Insert
- C. Riving Knife
- D. Storage
- E. Fence
- F. Elevation and Tilt Control
- G. Folding Cart

## POWER CONTROLS

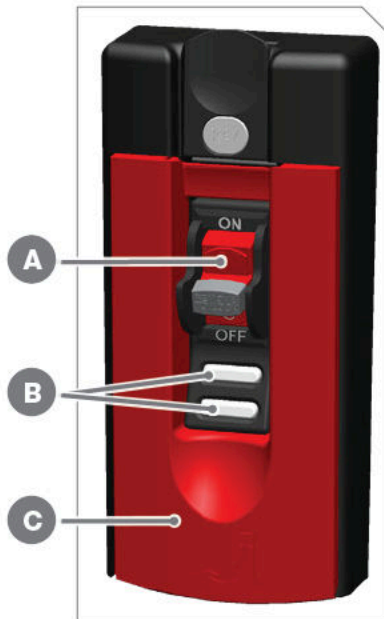

Use the power controls to run the saw and monitor the saw's status ([see page 45](#)).

- A. Power Switch
- B. Status Lights
- C. Start/Stop Paddle for Blade



Status lights can flash slow or fast ([see page 45](#)).

# LOCATION OF ACCESSORIES

## ACCESSORY DRAWER



- 1 Extend table to reveal storage drawer.
- 2 Pull drawer out to allow lid to open. Press clips to release accessories (2A).

## LOCATION OF STORAGE DRAWER ACCESSORIES

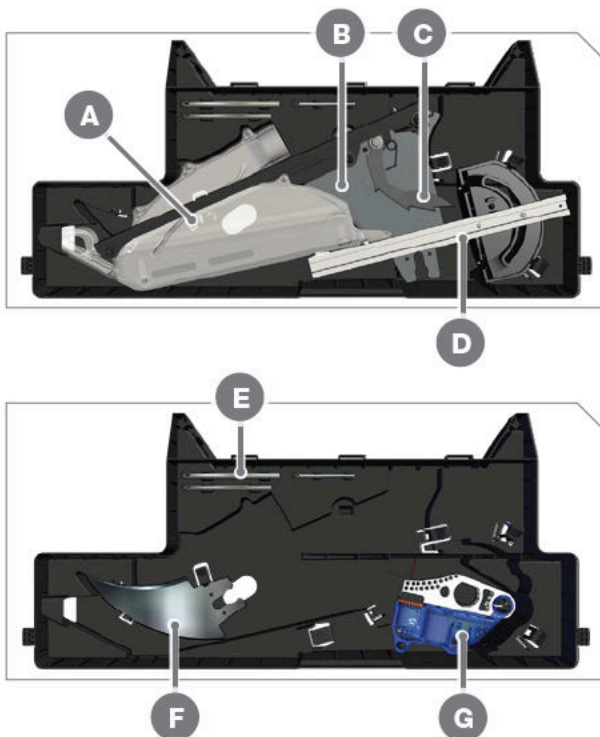

The drawer stores items in two layers, with the riving knife and optional spare brake underneath.

- A. Blade Guard
- B. Spreader
- C. Anti-Kickback Pawls
- D. Miter Gauge
- E. Hex Key Wrenches
- F. Riving Knife
- G. Storage for Optional Spare Brake

## FENCE, POWER CORD, AND PUSH STICK STORAGE

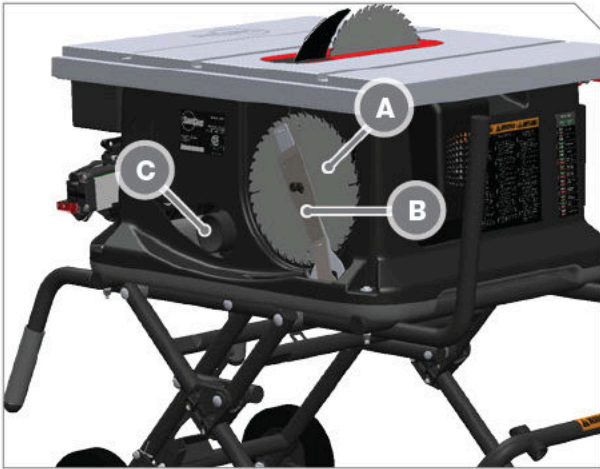

- A. Spare Blades
- B. Blade Wrenches
- C. Dust Port ([see page 37](#))



### FENCE

Slide fence fully into storage holsters and flip latch down to lock in place. Pull up on fence lever to release latch and remove fence.

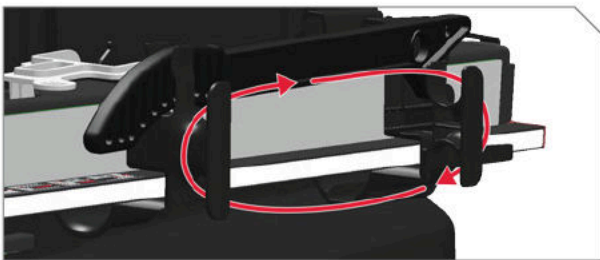

### POWER CORD

Wrap power cord around brackets on right sides of holsters, as shown by red arrows.



### PUSH STICK

Insert push stick into opening above brackets, then push until it stops. Swing handle end of push stick into clamp on front holster and push down to lock push stick in place.



## MOBILE CART

### SETUP AND TRANSPORT



- 1 To open mobile cart, grasp both handles and raise cart and saw to upright position. Press lock release lever with right foot (1A) and pull handles toward you.



- 2 Lower handles until cart locks in open position.



- 3 Make sure cart does not wobble. If needed, loosen wing nuts and adjust leveling feet, then re-tighten wing nuts (3A).



Always use the saw and the mobile cart on a level surface. Unplug and store the power cord before moving the saw.



4

To collapse cart for transport, depress lock release lever with foot (4A) and lift both handles.



5

Raise handles until the cart and saw are completely upright. Ensure lock bar fully engages lock pin.



6

To move saw, grasp both handles and tilt cart backward to roll on wheels.

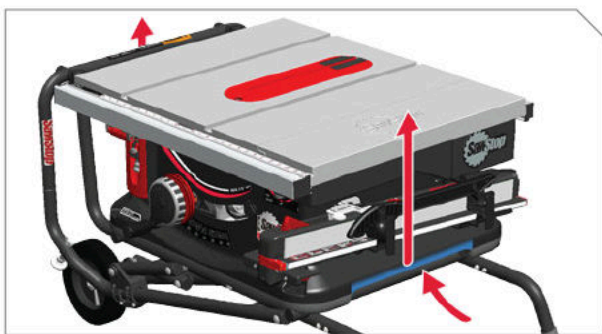

7

To lift saw, grasp hand grips on saw. The hand grips are molded into the bottom left and bottom right sides of the saw cabinet.



The saw and the cart weigh approximately 113 pounds (51 kilograms). Be careful and use proper lifting technique to avoid injury. Two people are required to lift the saw.

## REMOVE/INSTALL MOBILE CART



1

Raise the cart. Locate bolt on each corner.

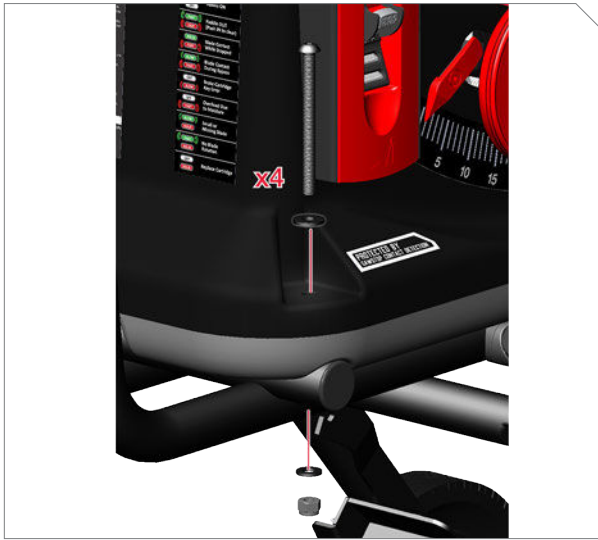

2

Use 5 mm hex key wrench and 13 mm wrench to remove hardware from saw corners.



3

Use the hand grips to lift saw straight up and off cart. To re-attach saw, reverse steps.



The saw weighs approximately 84 pounds (38 kilograms). Be careful and use proper lifting technique to avoid injury. Two people are recommended.

# REMOVE/INSTALL TABLE INSERT

## REMOVE TABLE INSERT



1 Switch power off and unplug the power cord.

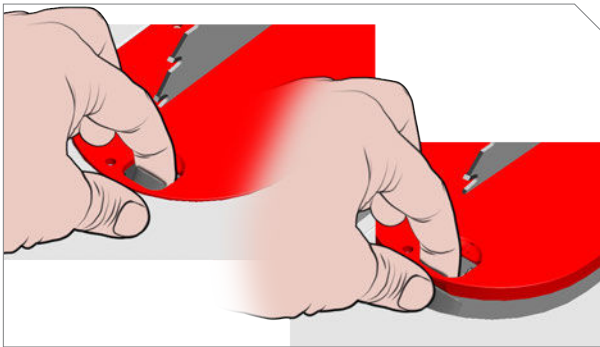

2 Press latch until insert pops up.

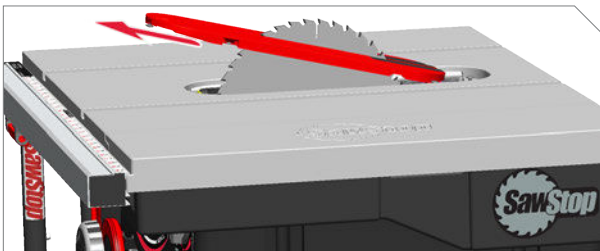

3 Slide insert up and out.

## INSTALL TABLE INSERT

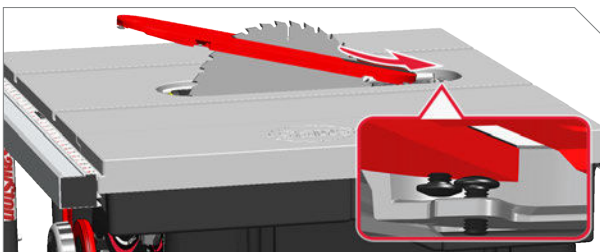

1 Slide in so rear screws overlap. Press front of insert down to lock in place.



**Never operate the saw without the table insert in place.**

# REMOVE/INSTALL BLADE

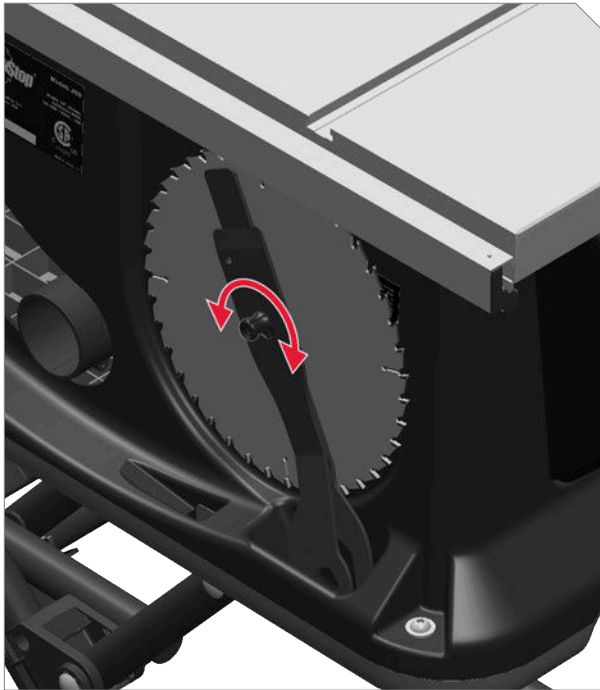

- 1 Switch power off and unplug power cord. Remove table insert and riving knife/blade guard. Release wrenched by turning knob 1/2 turn.

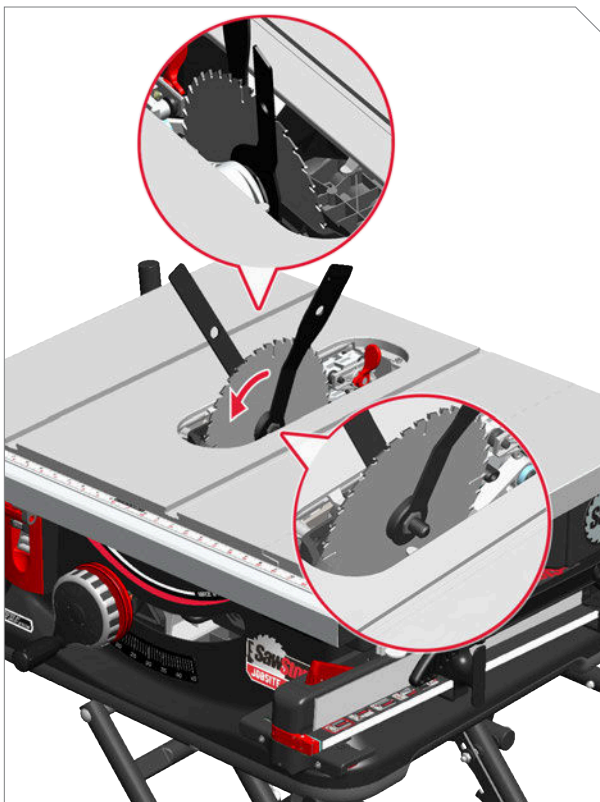

- 2 Loosen blade nut with wrenches. Remove nut and washer, change blade, and then reinstall washer and nut. Tighten nut with wrenches—do not over-tighten. Make sure direction of blade rotation matches direction of teeth, as indicated by red arrow. Reinstall table insert and riving knife/blade guard.



**Always switch the power off and unplug the power cord before changing the blade.**

# BLADE GUARD AND SPREADER

## HOW TO USE BLADE GUARD

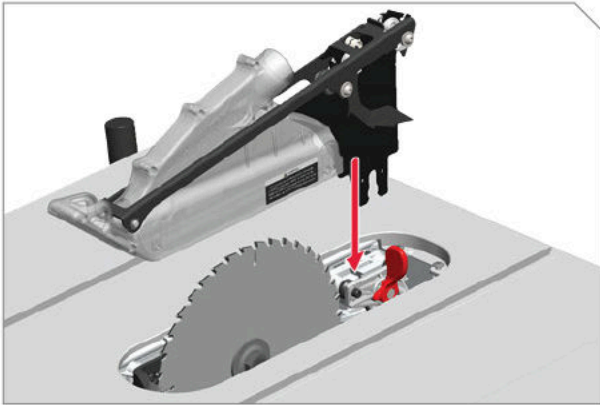

Use the blade guard and spreader for every operation for which they can be used, including all through-sawing.

1

Switch power off, unplug the power cord and remove table insert. Install blade guard into clamp.

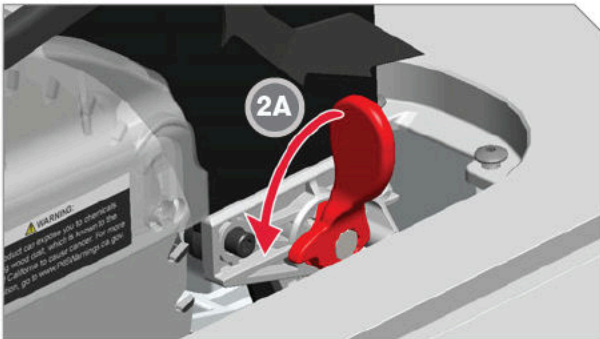

2

Rotate clamp handle down (2A, 2B) to secure blade guard in place. Install table insert. Reverse steps to remove blade guard.



3

To cut, raise top of blade above material. Place material flat on table and push slowly and smoothly into blade. Guard will adjust to material height.

i

To install or remove table insert, blade guard must be lifted ([see page 31](#)).

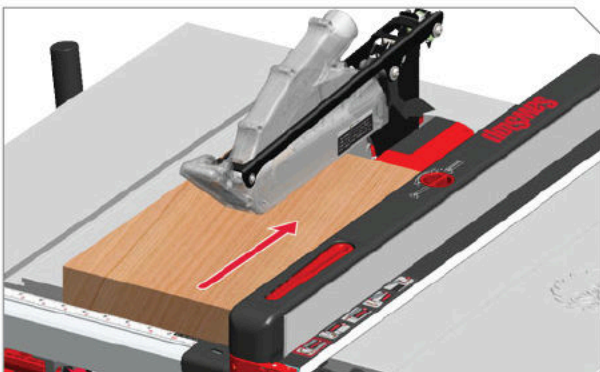

## REMOVE/INSTALL BLADE GUARD

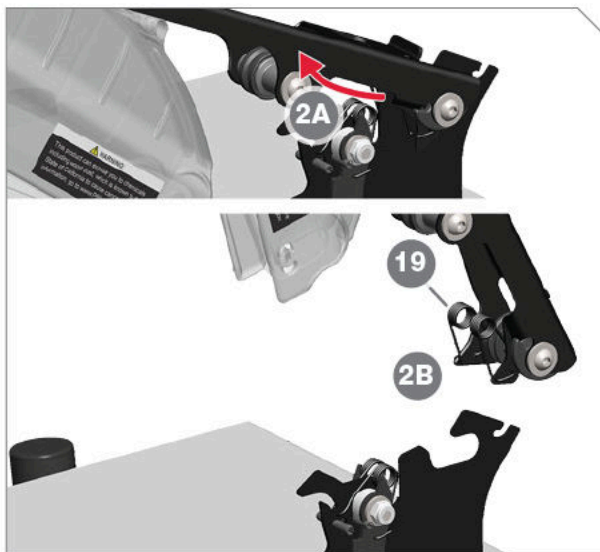
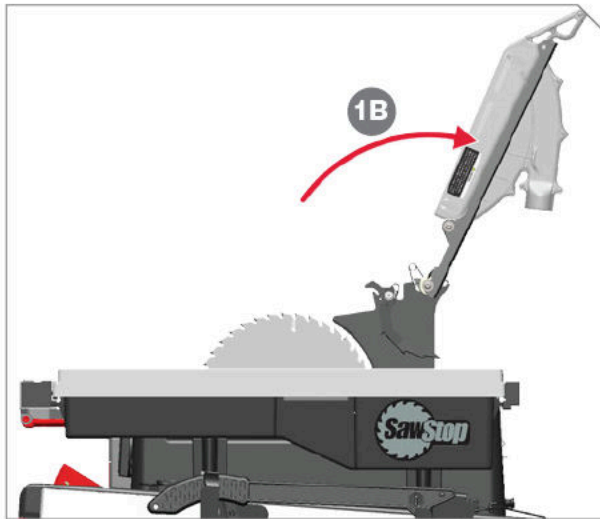
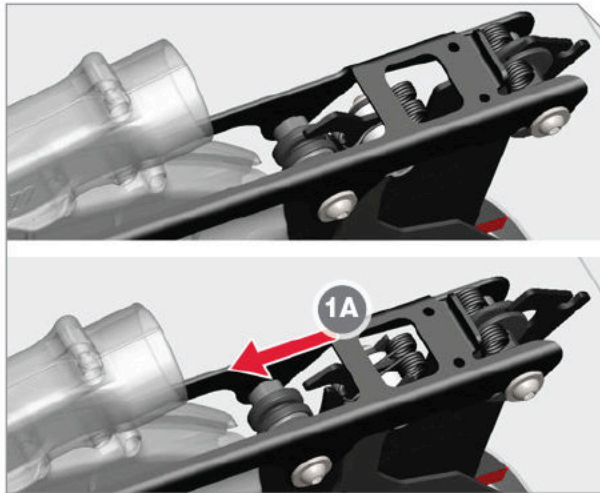

1

To provide easy access when changing blades, raise blade guard away from table. Pull guard forward (1A) then rotate it up and back (1B). Reverse steps to place the guard back in locked position for use.

2

To completely remove the blade guard, rotate up and pull forward (2A) until the guide and height adjustment wheels are clear of the brackets (2B). Continue to lift and rotate until the top guard spring (19) releases from the bracket.

Store guard in storage drawer when not in use (see page 23). Reverse steps to reinstall guard.

## ANTI-KICKBACK PAWLS

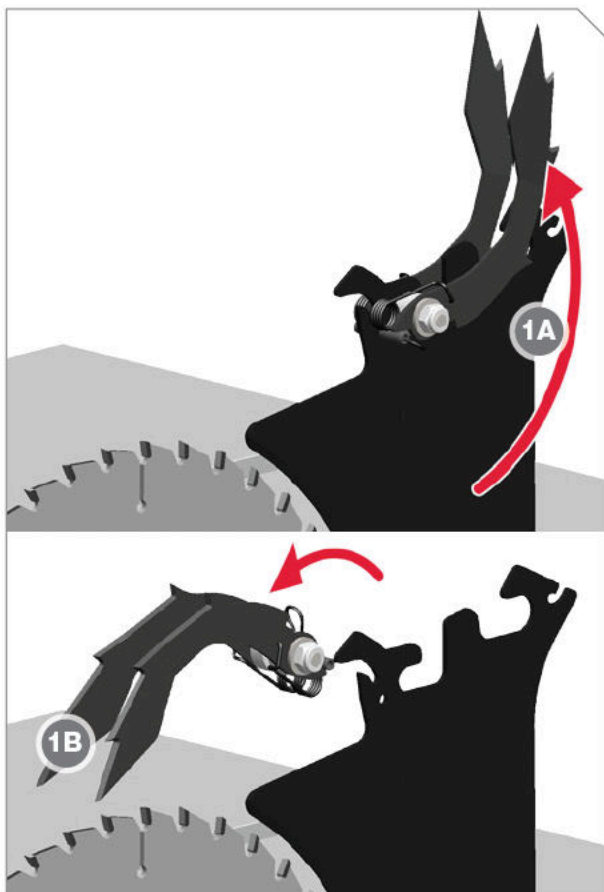

1

Leave pawls down to reduce likelihood of kickback. If you need to remove pawls, first remove guard, and then pull pawls back, up (1A) and forward to remove (1B). Store pawls in storage drawer (see page 23). To install pawls, reverse process.



**Always switch the power off and unplug the saw before removing or installing the blade guard, spreader, or riving knife.**

i

When the blade guard is not in use, storage places are provided in the accessory drawer for the blade guard, anti-kickback pawls, spreader, miter gauge and riving knife.

# RIVING KNIFE

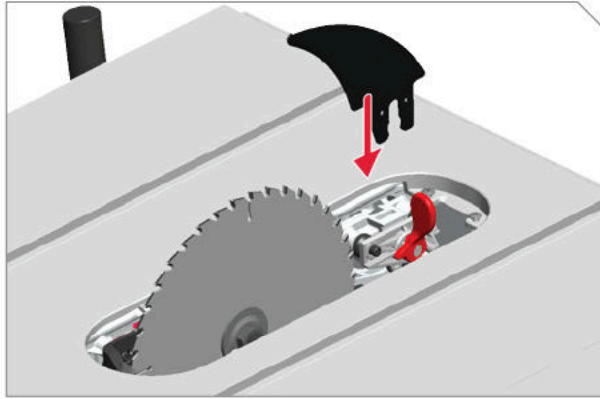

- 1 Switch power off, unplug the power cord and remove table insert. Install riving knife into clamp.

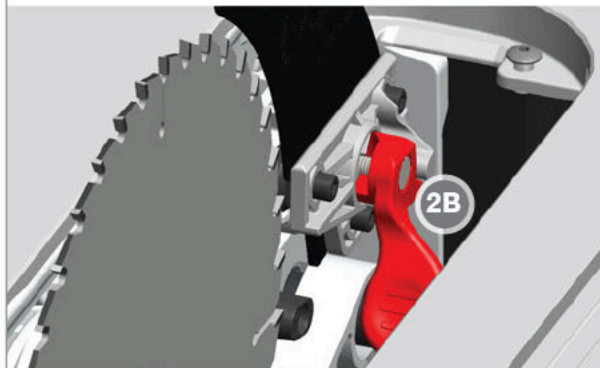
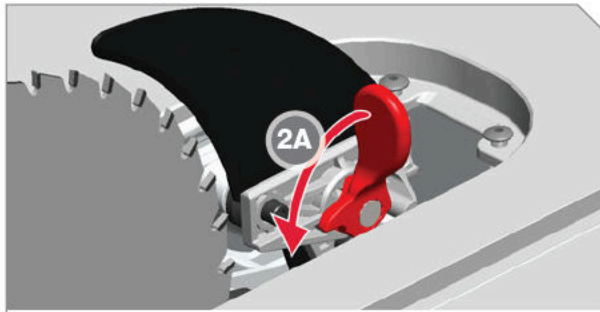

- 2 Rotate clamp handle down (2A, 2B) to secure riving knife in place. Install table insert. Reverse steps to remove riving knife.



- 3 Place material flat on table and push slowly and smoothly into blade.



Use the riving knife for every operation where the blade guard cannot be used. Neither the blade guard nor riving knife can be used when making Dado cuts.

# BRAKE CARTRIDGE

## HOW TO CHANGE BRAKE

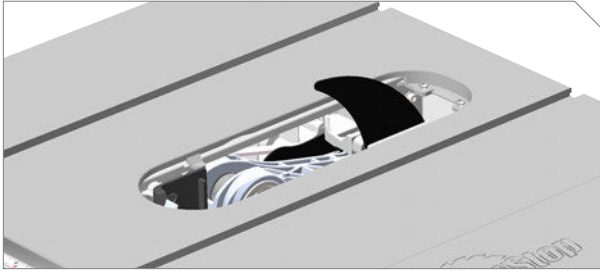

Always switch the power off and unplug the power cord before changing the brake.

1

Switch power off and unplug the power cord. Raise blade fully and set blade tilt to zero degrees. Remove table insert. Remove the blade.

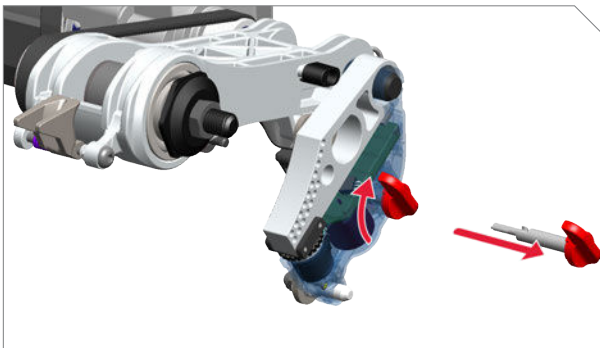

2

Turn brake key 1/4 turn clockwise and pull out.

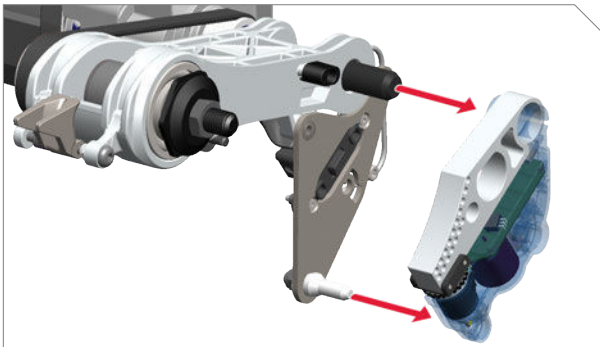

3

Pull brake off pins.

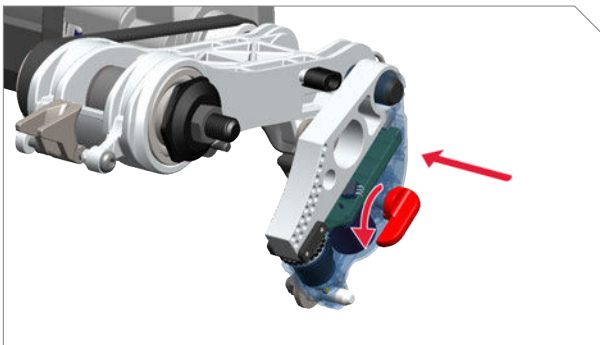

4

Slide new brake onto both pins. Insert key and rotate 1/4 turn counter-clockwise to lock in place. Reinstall riving knife/blade guard and table insert.

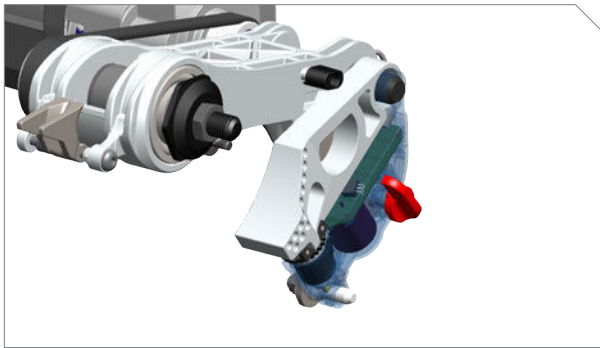

5

Install an optional Dado brake for 8" Dado sets.

## HOW TO REPLACE ACTIVATED BRAKE CARTRIDGE

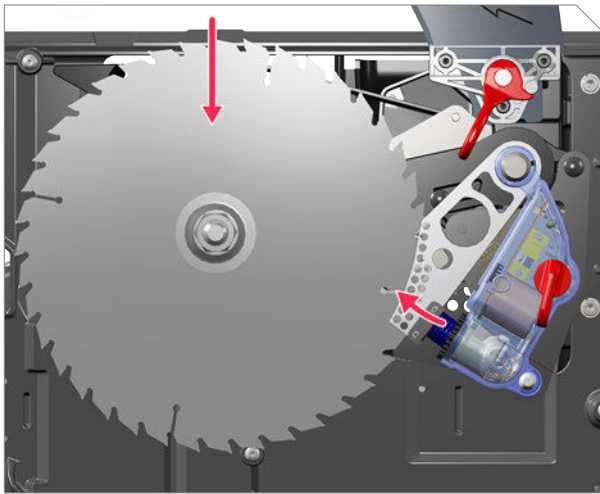

Upon brake activation, blade will stop spinning and may drop below table (unless blade was spinning slowly). You must change brake and blade to reset your saw.

**Always switch the power off and unplug the power cord before changing the brake.**

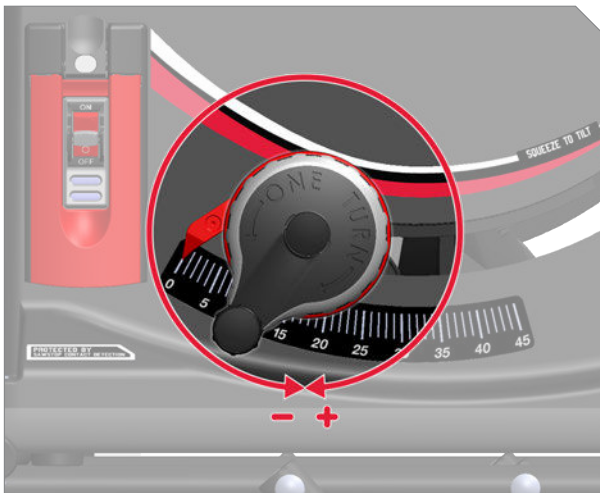

1

Switch power off and unplug the power cord. Rotate elevation handwheel fully counter-clockwise then fully clockwise to reset blade.

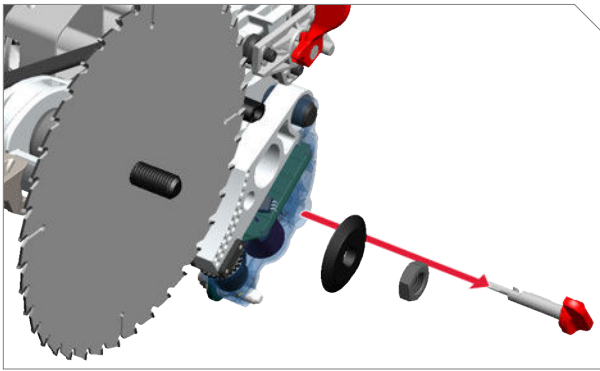

2

Remove table insert and riving knife or blade guard. Remove brake key, arbor nut, and washer.

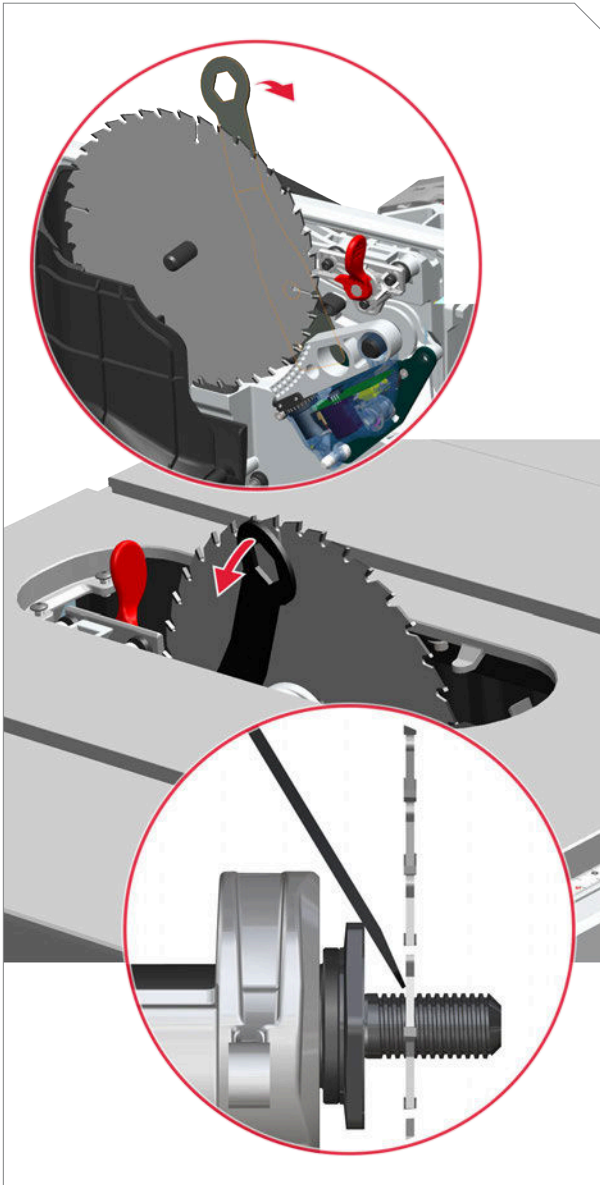

3

Use blade wrench to push brake slightly toward end of mounting pins.

4

Use blade wrench with beveled end as a lever to push blade slightly toward end of arbor.

Repeat steps 3 and 4 until blade and brake are free. Install a new brake and blade. Reinstall riving knife/blade guard and table insert.

# ATTACH DUST COLLECTION

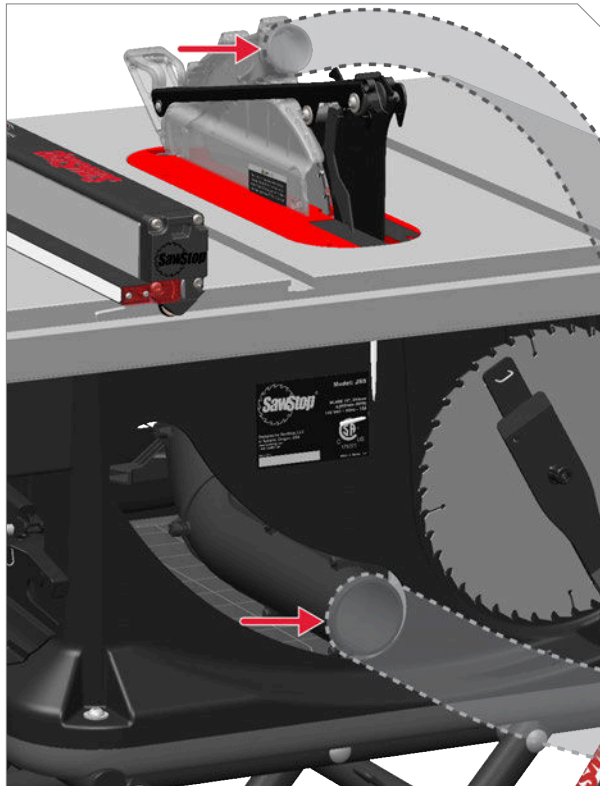

1

Connect suitable dust collector, which provides at least 170 CFM (4800 LPM) of airflow, to rear dust ports on saw and blade guard, using flexible connectors.

Always use a dust collection system when making cuts.

COLLECTOR SPECIFICATIONS	
Vacuum	170 CFM (4800 LPM)
Hose Diameter, Blade Guard (Inner)	1 3/8" (35 mm)
Hose Diameter, Blade Guard (Outer)	1 11/16" (43 mm)
Hose Diameter, Back of Saw (Inner)	2 1/4" (57 mm)
Hose Diameter, Back of Saw (Outer)	2 9/16" (65 mm)

For more information, see *Woodshop Dust Control*, by Sandor Nagyszalanczy, Taunton Press, 2002.



**WARNING!** Some types of dust created by sawing, power sanding, grinding, drilling, and other construction activities contain chemicals known to cause cancer, birth defects or other reproductive toxicity or harm. Some examples of these chemicals are lead from lead-based paints, crystalline silica from bricks, cement, and other masonry products, and arsenic and chromium from chemically treated lumber. In addition, wood dust has been listed as a known human carcinogen by the U.S. government. The risk from exposure to these chemicals and to dust varies depending on how often you do this type of work. To reduce your exposure, work in a well ventilated area and work with approved safety equipment including dust masks or respirators designed to filter out such dust and chemicals.

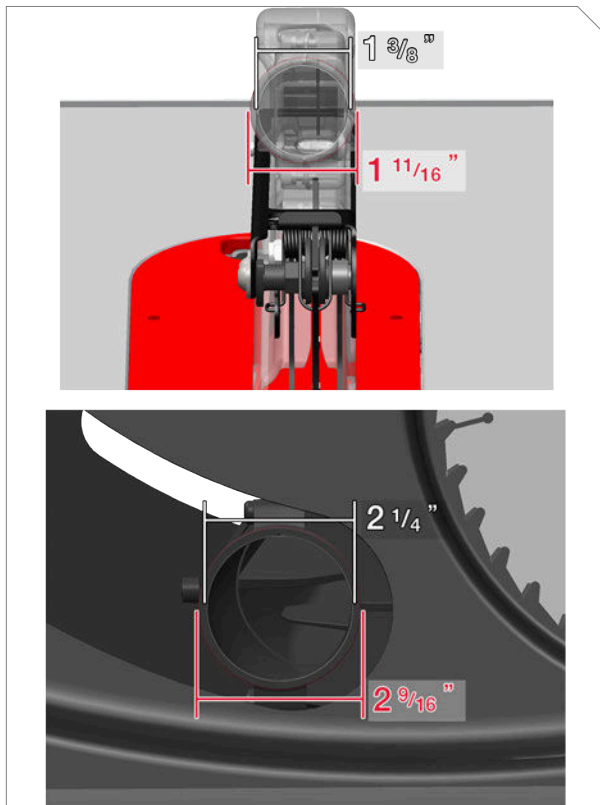

# SET BLADE ELEVATION AND TILT



**1** Rotate elevation hand wheel clockwise (1A) to raise blade, or counter-clockwise (1B) to lower blade. A single rotation adjusts blade elevation from fully lowered to fully raised, and vice versa.

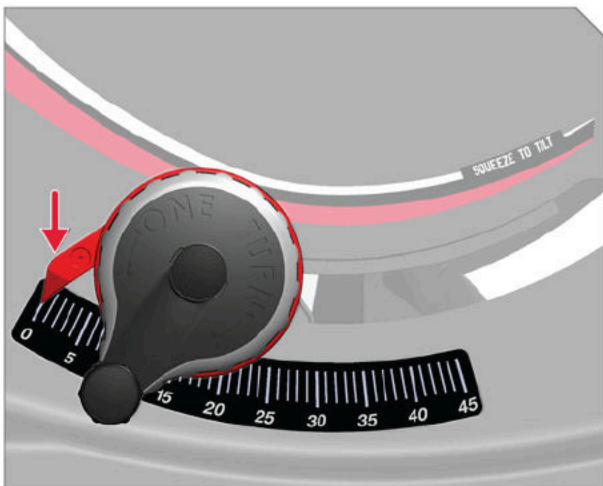

**2** Blade tilt angle is indicated by position of red pointer over tilt scale.

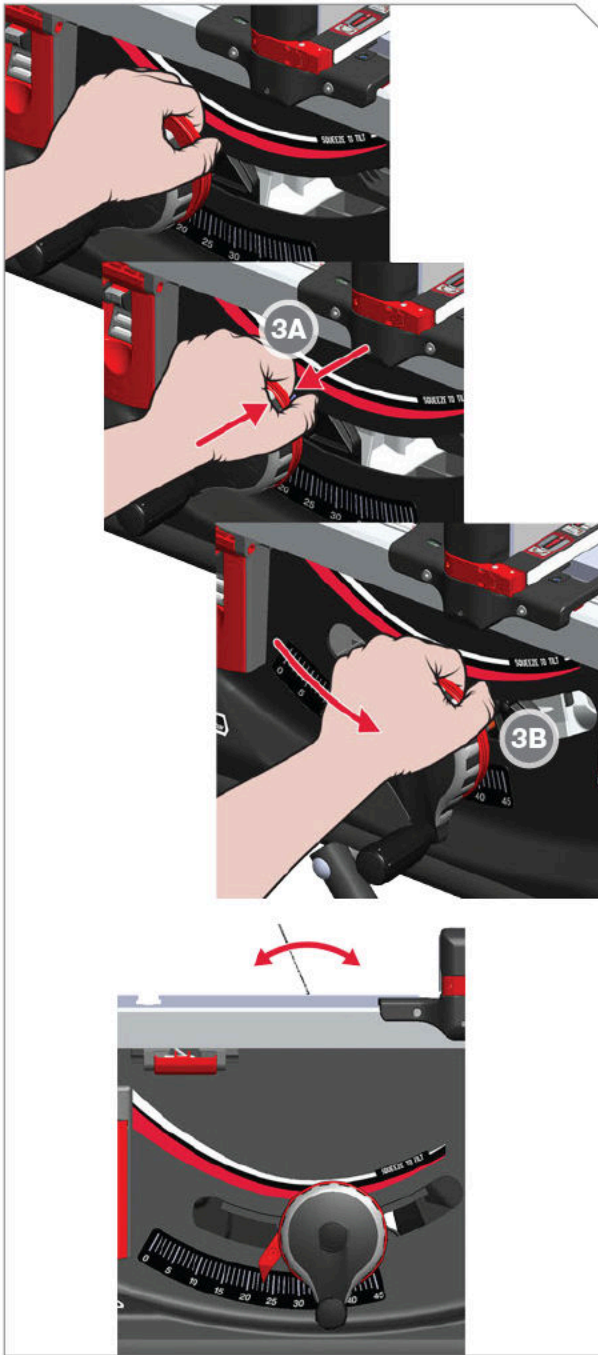

3

Change tilt angle by squeezing backplate against hand wheel (3A) and sliding hand wheel to side (3B) . Release backplate to lock blade in place. This adjusts tilt angle in single degree increments.



4

Adjust tilt angle in fractional degree increments by rotating tilt adjustment knob.



Never use the fence on the left side of the blade when making a bevel cut (the blade is tilted). The cut piece can bind between the fence and blade and could result in injury or damage the saw. Further, the blade could contact the fence resulting in damage and brake activation.

## RIP FENCE AND EXTENSION TABLE



Use fence to guide material during rip cuts.

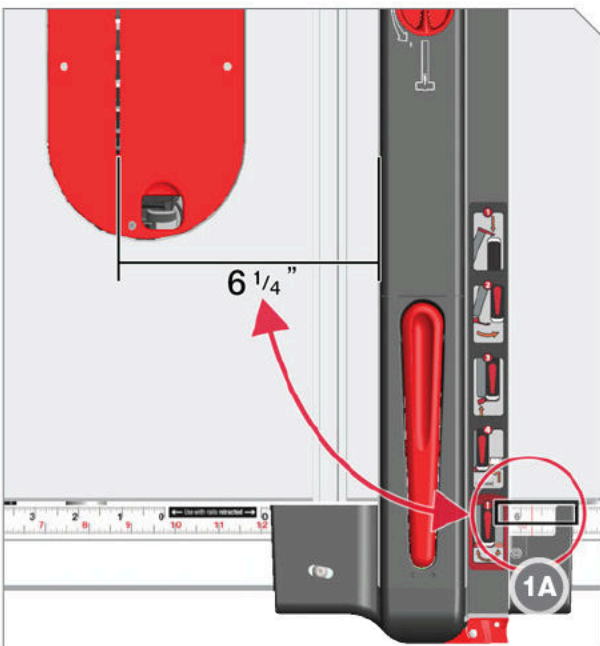

1

Use the red indicator line (1A) to determine the cutting width.

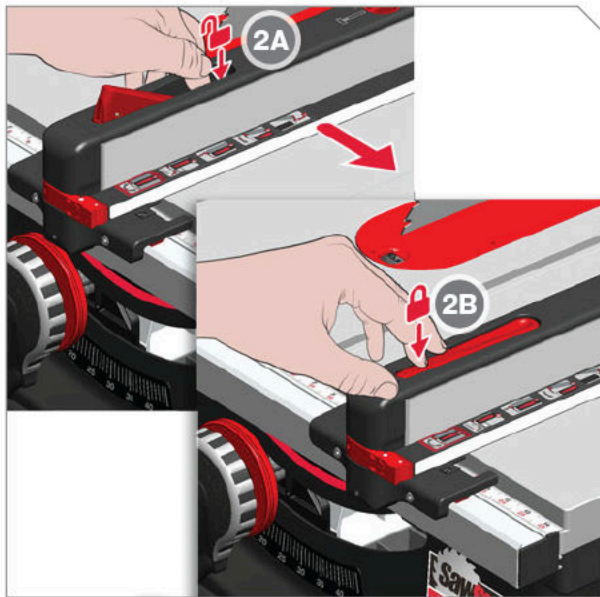

**2** To move the fence, push lever down to unlock the fence (2A), and then slide fence until the indicator line reads desired cut width. Push down on the opposite end of the lever (2B) to lock the fence in place.



**Always use the fence when making rip cuts. Never perform a ripping operation freehand-this may result in serious injury.**

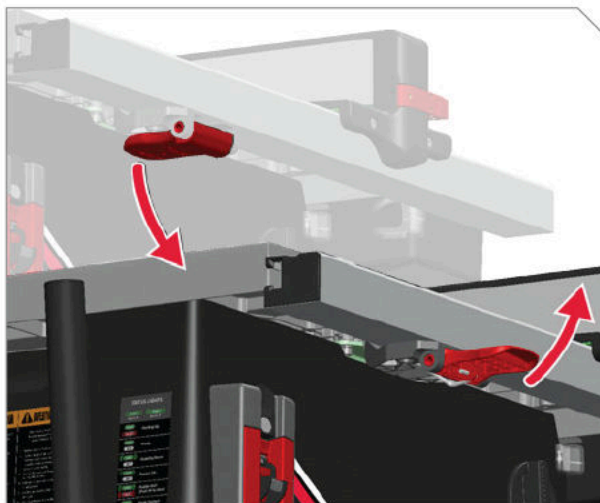

**3** Extend table for rip cuts wider than 12" (30 cm). Flip handle out to unlock the table.



**4** Slide the table to the right (4A) to extend. Flip handle towards the saw (4B) to lock table in place. The rails for the table must be fully extended to lock the handle.



**Do not use the saw unless the table is locked in one of the two positions: either fully closed (not extended) or fully open (fully extended).**

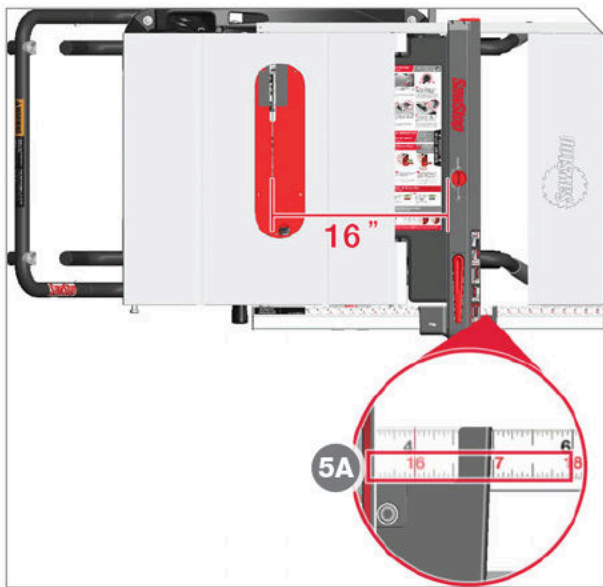

5

Use upper (black) scale with the table retracted. Use lower scale (5A) with the table extended.

i

Scale values are only correct when table is fully retracted or fully extended.



Do not use the saw unless the table is **locked** in one of the two positions: **fully closed** (not extended) or **fully open** (fully extended).

## LOW FENCE



- 1 The fence is equipped with a low fence. Use the low fence when cutting thin material or narrow strips of material.

The low fence is one inch wide; subtract one inch from the values on the ruler when using the low fence.



- 2 Store low fence on right side of rip fence. Low fence can be used on either side of rip fence. To use low fence on left side of rip fence, pull lever forward (2A) and slide low fence slightly back to unhook rear.

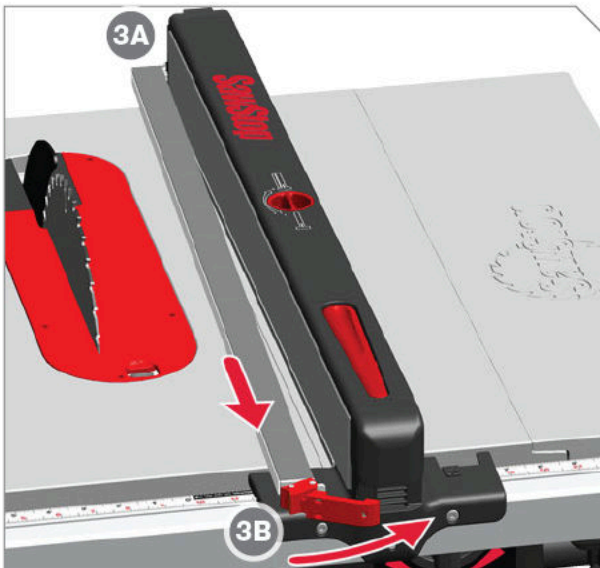

- 3 Flip low fence over and hook rear end on left side of rip fence (3A). Push lever back to lock low fence in place (3B).



**Do not allow low fence to contact blade.**

## SUPPORT SHELF

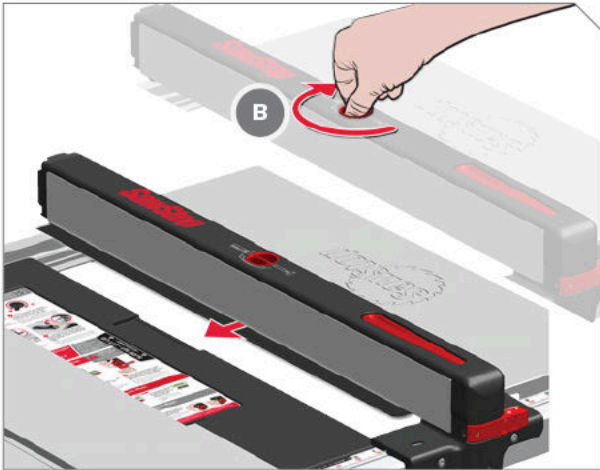

A support shelf is included in the rip fence. Use the shelf to support material (A) when the table is extended. Turn the support shelf knob clockwise (B) to extend shelf. Retract shelf when fence is over table or extension table.



The support shelf cannot be extended when low fence is attached to left side of rip fence.



**Always retract the support shelf when the fence is over the table. If the support shelf touches the blade, the brake will activate.**

# OPERATION

## ABOUT POWER CONTROLS

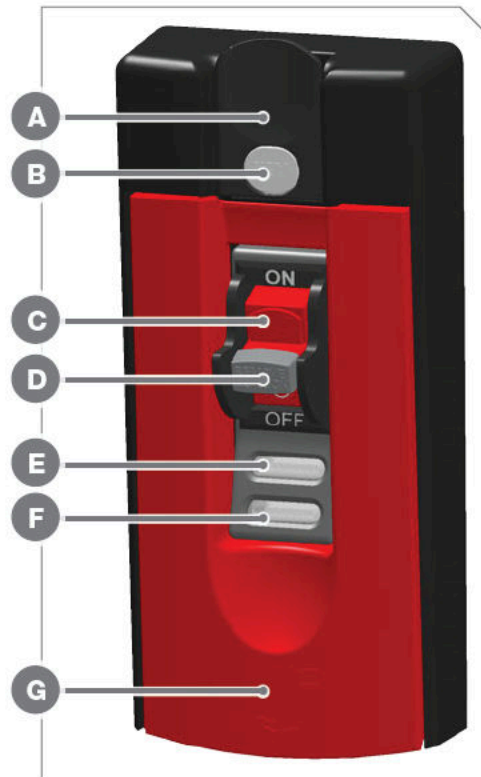

- A. **Bypass Switch.** Use to run the saw in Bypass Mode (see page 50).
- B. **Bypass Lock Out Key.** Remove to disable Bypass Mode (see page 51).
- C. **Main Power Switch.** Activates power for the saw (but does not spin the blade).
- D. **Lock Out Key.** Remove to disable the saw (see page 49).
- E. **Green Status Light** (see page 45).
- F. **Red Status Light** (see page 45).
- G. **Start/Stop Paddle.** Pull out to turn on the motor and spin the blade. Push in to turn off the motor (see page 47).

## STATUS LIGHTS & CODES

The green and red lights under the power switch indicate the status of the saw. The lights function independently or in combination, depending on the status. Either light can flash slow or fast, or be on continuously. The red light can flash once indicating the saw is in Bypass Mode (see page 50).



**Startup.** The safety system is initializing. Allow up to 10 seconds to complete and the red status light to turn off.



**Ready - Running.** Saw is ready or motor is running.



**Coasting Down.** Blade is coasting down. Do not touch blade or brake will activate.



**Bypass Mode Activated.** Red light flashes once, indicating Bypass Mode has activated (see page 50).



**Bypass Mode On.** Saw is in Bypass Mode.

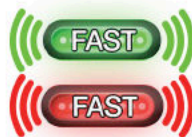

**Paddle Out.** Start/Stop paddle is out. Push in to clear.



**Blade Contact While Stopped.** Contact detected while blade was stopped. Wait 5 seconds for red status light to turn off.



**Blade Contact During Bypass.** Contact detected while saw is in Bypass Mode. Will clear when blade stops.



**Brake Key Error.** Turn power switch off and reinstall brake key.



**Overload Due to Moisture.** Material is too wet or green. Cycle power to clear. Allow material to dry or cut in Bypass Mode.



**Small or Missing Blade.** Switch power off, unplug the power cord and install 10" blade (or 8" Dado set and brake).



**Blade Stalled.** Cycle power and cut material more slowly. Call SawStop Technical Support if issue persists (see page 6).



**Replace Cartridge.** Cycle power. If error does not clear, replace brake.

## NORMAL MODE



### Non-Conductive Materials

Start your saw in Normal Mode ([see page 47](#)) to cut NON-CONDUCTIVE materials.

- Dry wood
- Dry plywood or OSB
- Dry pressure-treated wood
- MDF
- Plastic
- Solid surface
- Laminate
- Cardboard
- Foam



**Cutting conductive material in Normal Mode will cause the brake to activate.**

## START IN NORMAL MODE



**ALWAYS WEAR HEARING PROTECTION WHEN USING SAW!**

1

Switch power on.

Wait while safety system initializes. Red status light flashes slowly until saw is ready.



2

Ready. Red status light is off.





3 Pull paddle out to spin blade.



Never start the saw when the blade is in contact with the workpiece or any other object.

## STOP IN NORMAL MODE



1 Push paddle in.

Green status light flashes fast while blade spins down.



Do not touch the blade while it is coasting down. Your touch will trigger the brake.

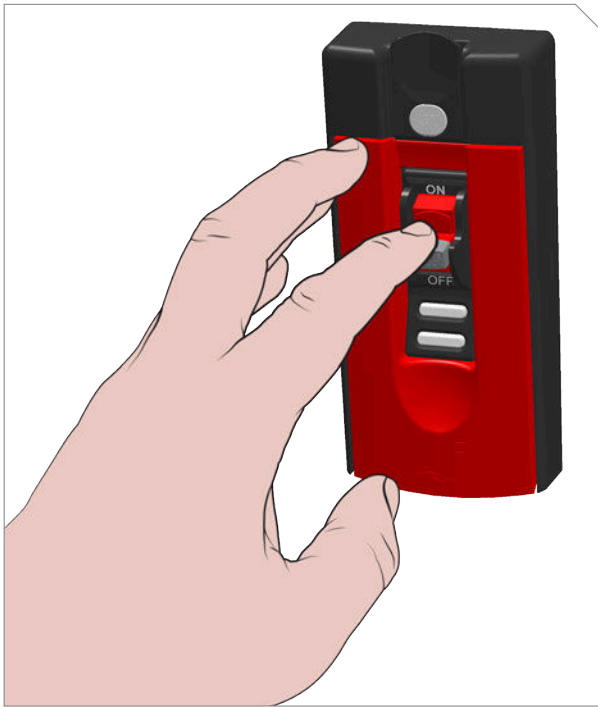

2

After all cuts are completed, switch power off.

### How to Disable Your Saw

i



Remove lock out key to disable saw.

## BYPASS MODE



### Conductive Materials

Start your saw in Bypass Mode to cut CONDUCTIVE materials ([see page 50](#)).

- Green or very wet wood
- Wet pressure-treated wood
- Very wet plywood or OSB
- Aluminum and other metals
- Carbon-filled materials
- Foil
- Mirrors



**There is no protection in Bypass Mode! Use Bypass Mode only to cut conductive materials or to test conductivity ([see page 51](#)).**

## START IN BYPASS MODE



There is no protection in Bypass Mode! Use Bypass Mode only to cut conductive materials or to test conductivity (see page 51).

1

Switch power on.

Wait while saw powers up. Red status light flashes slowly until saw is ready.

SOLID

(SLOW)

2

Ready. Red status light is off.

SOLID

OFF



3

Press and hold bypass switch above key. Wait for red light to flash once. DO NOT release switch.

SOLID

(ONCE)

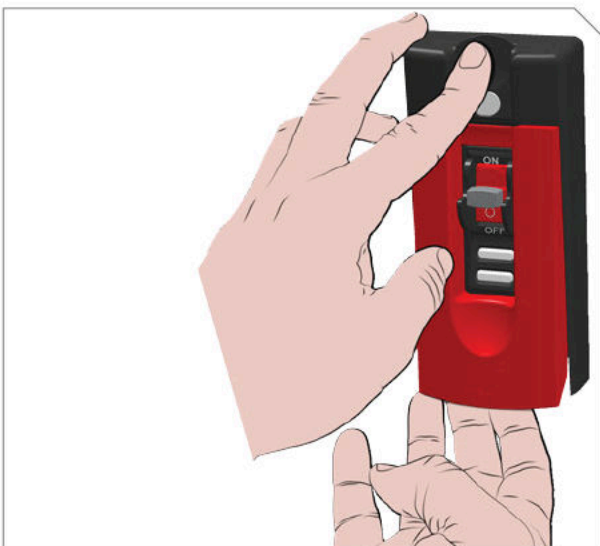

4

While pressing bypass switch, pull paddle out to spin blade. Keep pressing switch until red light flashes once, then release switch.

(ONCE)

**Bypass Mode**

(SLOW)

OFF

- You cannot start in Bypass Mode unless the brake cartridge is installed and all error codes are cleared.
- Green light flashes while in Bypass Mode.

## STOP IN BYPASS MODE



- 1 Push paddle in to stop blade. Green status light flashes fast while blade spins down. Saw exits Bypass Mode automatically after blade stops. After all cuts are completed, switch power off.



The saw is still in Bypass Mode until the blade comes to a complete stop! The saw returns to Normal Mode automatically after the blade stops.

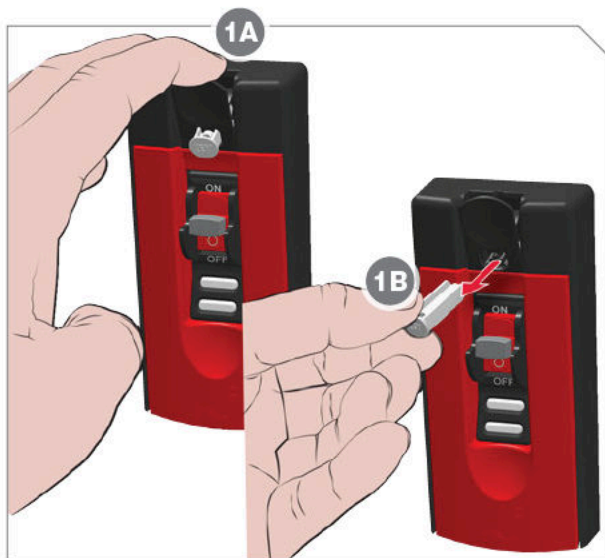

### How Disable Bypass Mode

- 1 Pull bypass switch out (1A) then remove the Bypass Key (1B) to disable bypass. Insert Bypass Key to re-enable.

### How to Test Material Conductivity

Use Bypass Mode to see if material is conductive and would cause the brake to activate. Start the saw in Bypass Mode (see page 50), and then carefully make several cuts on a scrap piece of the material.

The status code (combination of lights) shown here indicates material is conductive and must be cut in Bypass Mode to prevent brake from activating. If this status code is not displayed after several trial runs, then it is likely the material is not conductive and you can make future cuts in Normal Mode.





## MAINTENANCE

### USER-REPLACEABLE PARTS

The following is a list of typical user-replaceable parts, and where to find replacement instructions:

PART	PAGE
Blade	29
Cartridge	35
Table Insert	28
Riving Knife	33
Blade Guard	31
Spreader	31

### ALL PARTS

See the exploded views near the end of this manual for a complete listing of components and part numbers. For parts and further technical assistance contact SawStop ([see page 6](#)).

### POWER CORD

Periodically check the condition of the power cord; if the cord becomes damaged, it must be replaced by a specially prepared supply cord available through SawStop Service. The cord must be replaced by SawStop or an authorized service agent ([see page 6](#)).

## BLADE GUARD

Keep the blade guard free of accumulated saw dust, wood chips, and other debris. Vacuum out any dust as needed. Check that you have a clear view of the saw blade from all angles; make sure no abrasions or materials on the blade guard obscure your view. Before each use, check that the blade guard pivots up and down freely. It should rest completely on the table when not in use, and the side plate should contact the table when the blade is tilted to 45 degrees.

## CABINET

The interior of the cabinet should be kept free of accumulated saw dust, wood chips and other debris. Although most of the dust is collected by the dust collection system, it is normal to have some dust collect in the cabinet. Periodically check for dust inside the bottom of the cabinet, trunnion assembly, and dust shroud. Vacuum out the dust as needed to prevent any buildup.

# MAKE ADJUSTMENTS



Always make sure the motor is off, the power cord is unplugged and the blade is completely stopped before making any adjustments.



Your saw is factory-adjusted to meet strict requirements and should not generally need adjustment.

## ADJUST TABLE INSERT

### Vertical Movement

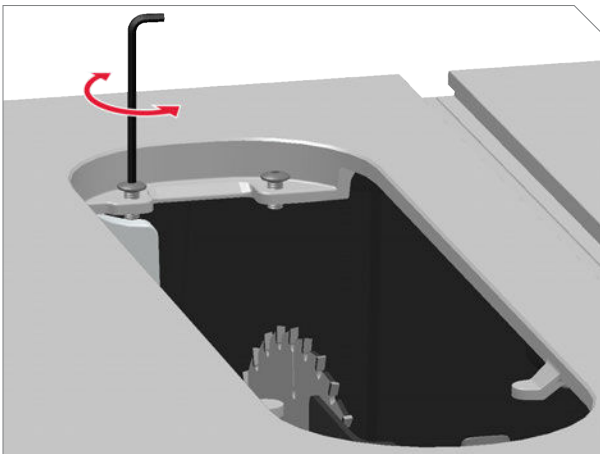

- 1 Remove insert. To reduce vertical movement, use a 3 mm hex key wrench to tighten both screws (clockwise). Reinstall insert. Press down on parts of insert to check that there is no movement.
- 2 If insert becomes difficult to install or remove, increase vertical movement by loosening screws (counter-clockwise). Check by reinstalling and removing insert several times.

### Align to the Table Top Surface

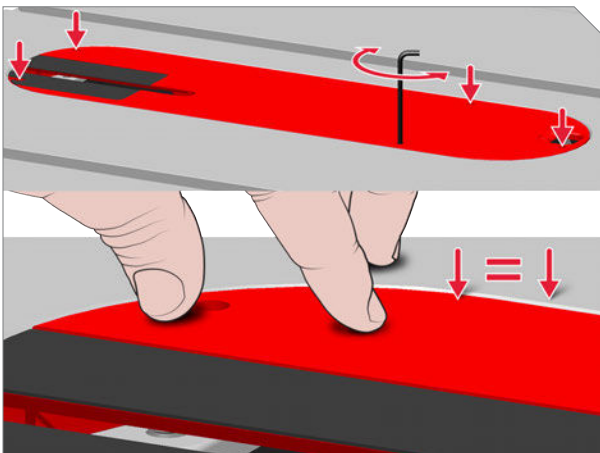

- 1 Use a 3 mm hex key wrench to rotate the 5 screws clockwise to raise insert or counter-clockwise to lower insert. Balance adjustments between all 5 screws.
- 2 Feel around edges of insert to ensure it is flush with tabletop. When pressing on insert, it should not rock or click.

## ADJUST FENCE

### Clamping Force

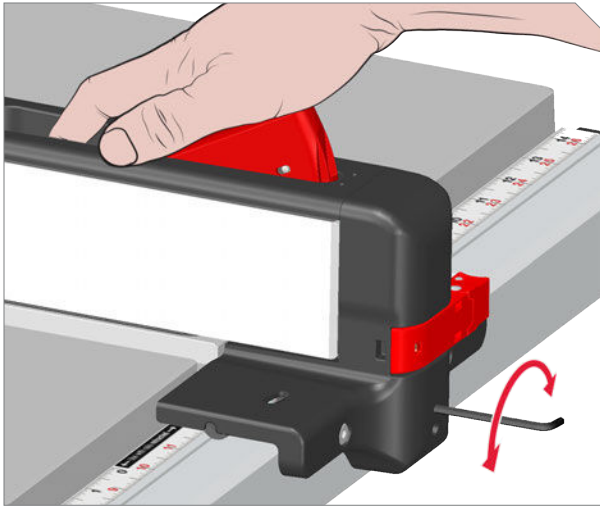

- 1 Unlock fence and insert a 3 mm hex key wrench into hole in front of fence. Turn clockwise to tighten or counter-clockwise to loosen. Check clamping force by locking and unlocking fence several times. Make further adjustments as necessary.

### Alignment



- 1 Unlock fence and position with one side flush with a miter gauge slot. Lock fence. Check that face of fence is flush with miter slot edge along whole length. If there is misalignment, continue to next step.

**i** When locking, fence may shift. If this occurs, unlock fence, adjust, and re-lock.

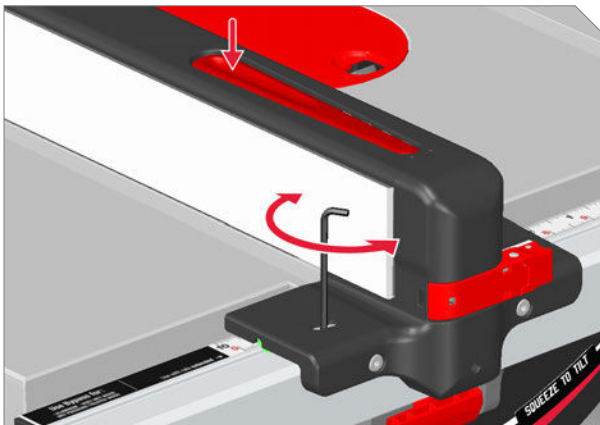

- 2 Unlock fence. Use a 3 mm hex key wrench to slightly loosen screw in top left side of fence head.

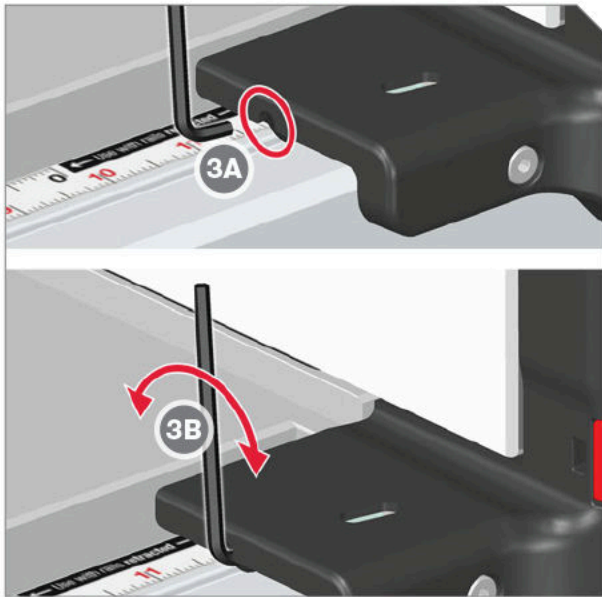

- 3 Insert 3 mm hex key wrench (3A) at an angle into hole in left side of fence head. Rotate screw (3B) clockwise to shift fence left, or counter-clockwise to shift fence right. Lock fence and check alignment. Make further adjustments as necessary. When fence is parallel to the miter slot, tighten screw in top left side of fence head. (Reverse Step 2)

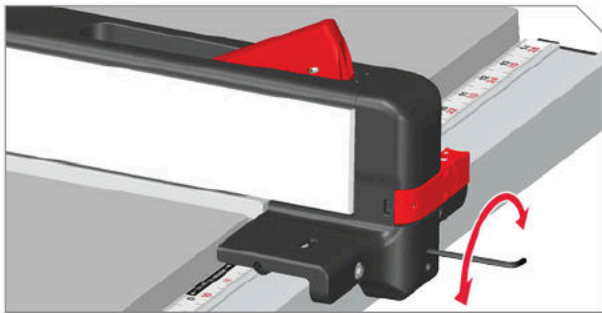

- 4 Once fence alignment is done, lock and unlock fence to make sure it is still tightly secured to rail. If fence slides while locked, or feels loose, use a 3 mm hex key wrench to tighten screw on front of fence.

## Adjust Indicator Lens

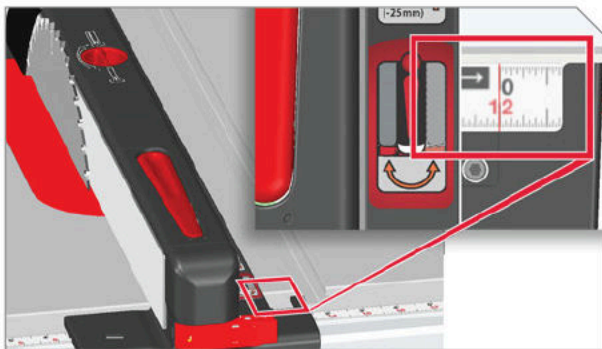

- 1 Raise blade fully. Make sure the table is fully retracted. Move fence so its left side rests against right side of blade. If indicator lens reads 0" (0 mm) on ruler, no adjustment is needed. If indicator does not read 0" (0 mm) proceed to next step.

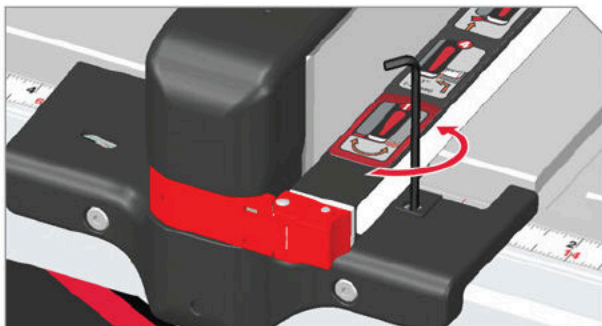

- 2 Use a 3 mm hex key wrench to loosen bolt next to indicator lens.

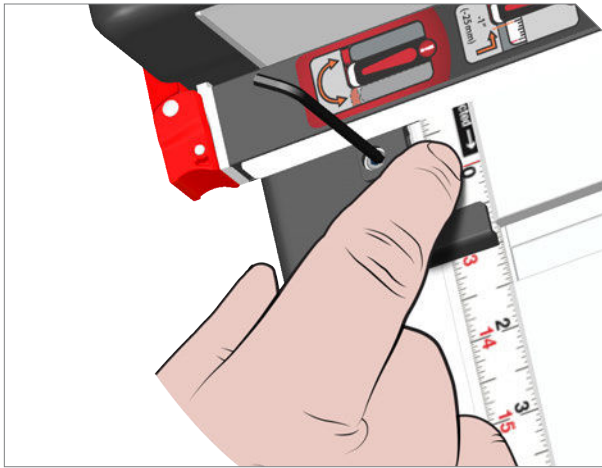

3

Slide lens by hand to correct location. If easier, you can also remove the fence and slide the lens from the underside of the fence.

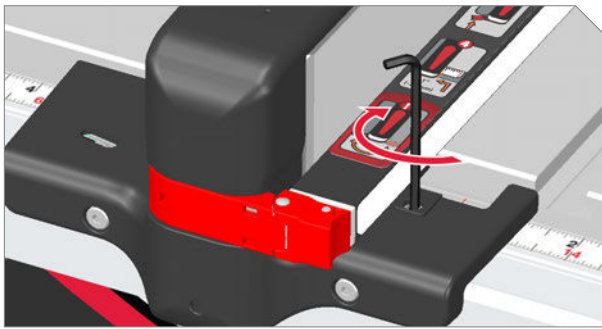

4

Tighten bolt. Check position of lens and make further adjustment as necessary.

## ALIGN BLADE TO TABLE

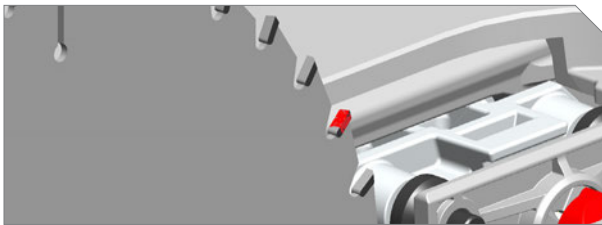

1

Remove table insert and blade guard. Raise blade.

Mark one of the teeth. Rotate the blade so the tooth is at the back of the blade.

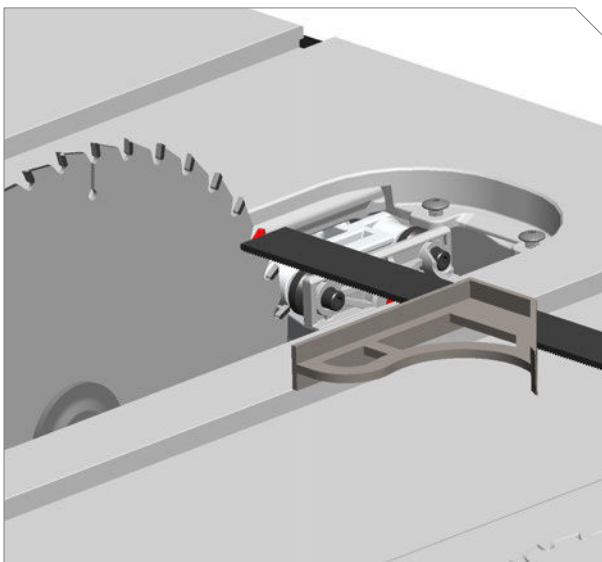

2

Set combination square parallel with right miter slot. Extend ruler until it lightly touches the side of the marked tooth. Tighten the locking knob on the combination square.

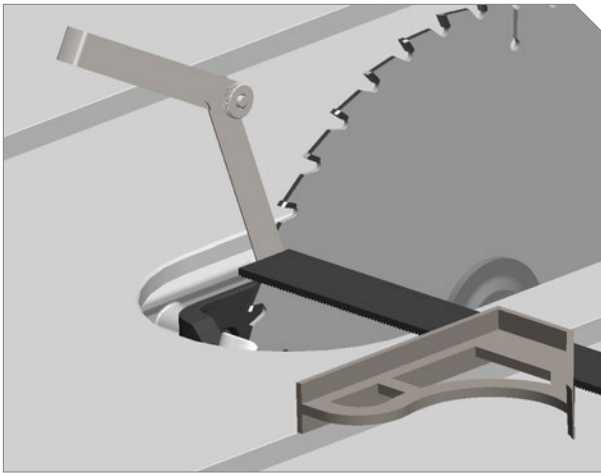

2

Now rotate the blade so the marked tooth is at the front of the blade. Move the combination square to align with the tooth. If there is a gap, measure the gap with a feeler gauge. If measurement is within 0.01" (0.025 mm), no adjustment is needed. If not, proceed to next step.

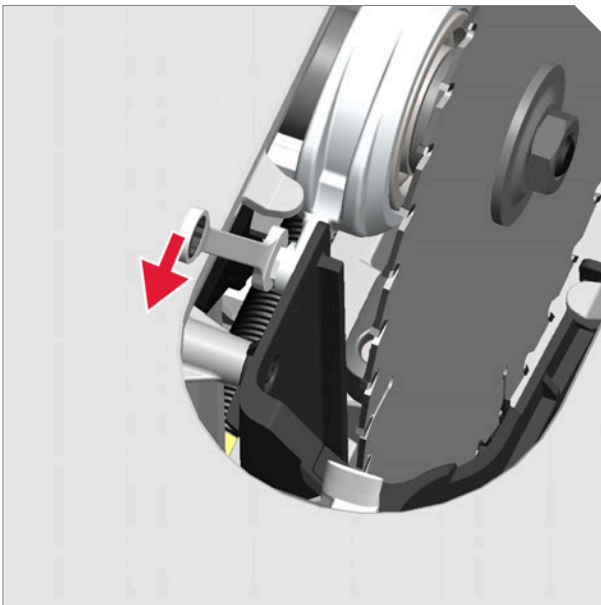

3

Loosen arbor nut and slide blade over slightly.

Use a 10 mm end-wrench to break loose the lock nut on the adjustment bolt. Just break loose enough to turn the bolt, do not loosen beyond that point.

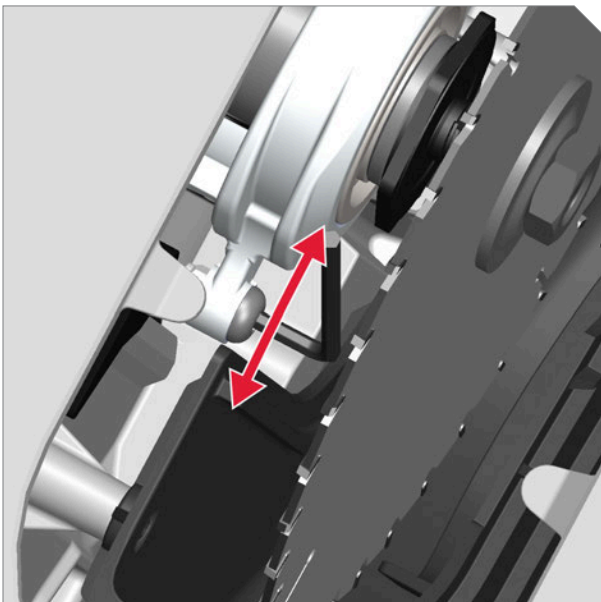

4

Use 4 mm hex key wrench to rotate bolt: if there was a gap, turn counterclockwise to move blade right until the gap is removed or less than 0.01" and clockwise to move blade left.

Once adjusted, use the hex key wrench to hold the adjusting bolt in-place, and then tighten the lock nut.

Tighten the arbor nut.

## ALIGN EXTENSION TABLE

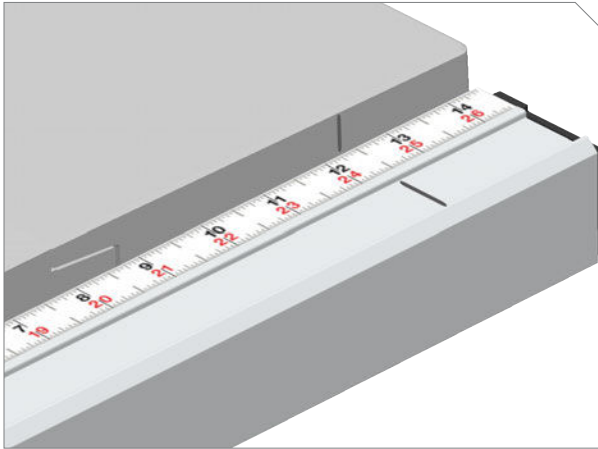

1

Use a pencil to mark the extension table and rail in the same location for alignment purposes in later steps, or make note of where end of table meets rail ruler.

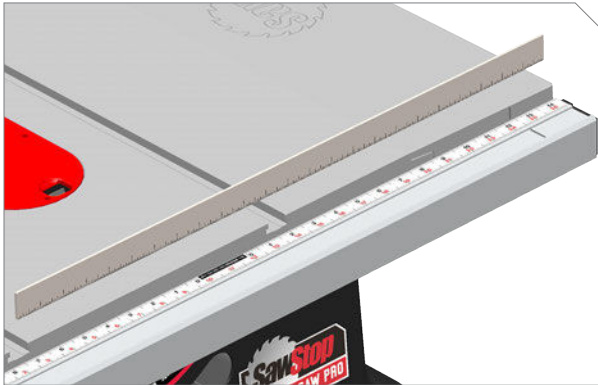

2

Place a straightedge across table and extension table, parallel to rail.

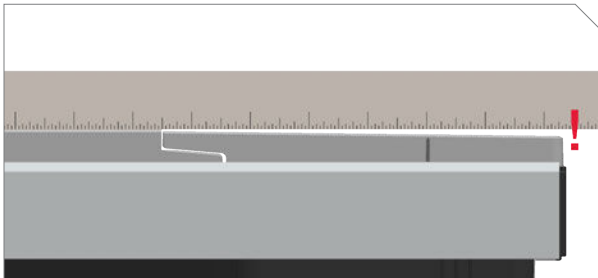

3

Check for gap between extension table and straightedge. If there is a gap, use a feeler gauge to determine size. If gap less than 0.05" (1.3 mm), extension table aligned, so no adjustment needed. If gap is larger than 0.05" (1.3 mm), proceed to next step.

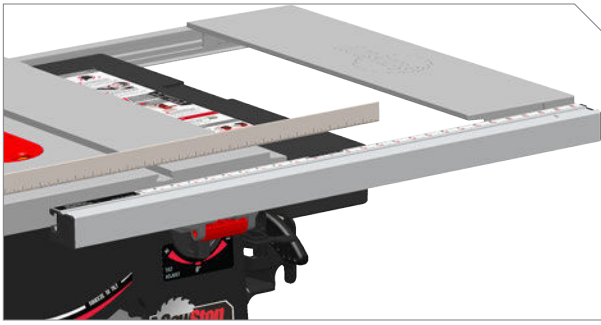

4

Extend and lock extension table.

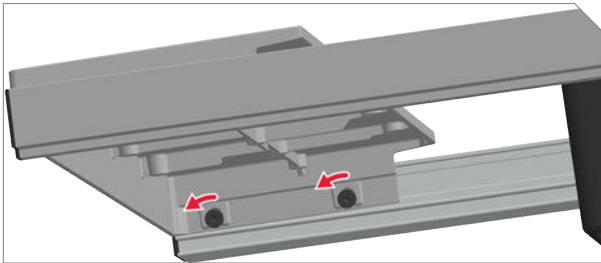

5

Use a 4 mm hex key wrench to SLIGHTLY loosen the two screws between front rail and extension table. Push down or pull up on extension table as necessary to correct alignment.

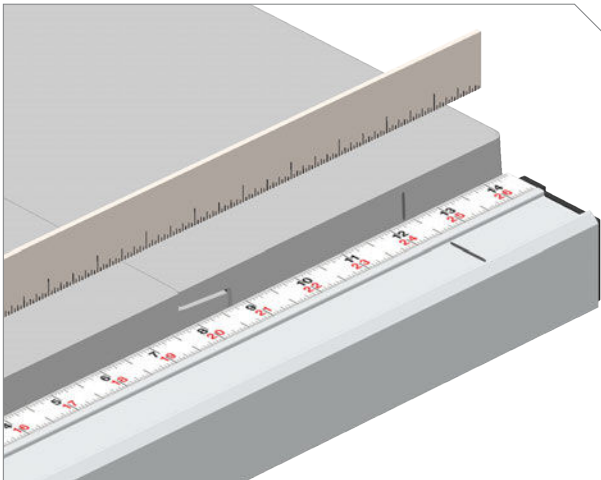

6

Unlock, close, and re-lock extension table.

Recheck alignment. Make further adjustments if necessary. Once alignment is correct, check pencil mark made earlier, or noted ruler measurement, to ensure extension table is still aligned with rail. If marks align, proceed to step 7. If marks do not align, extension table has shifted side-to-side relative to rail. Readjust extension table to align marks. Use straightedge to recheck vertical alignment, then recheck marks.

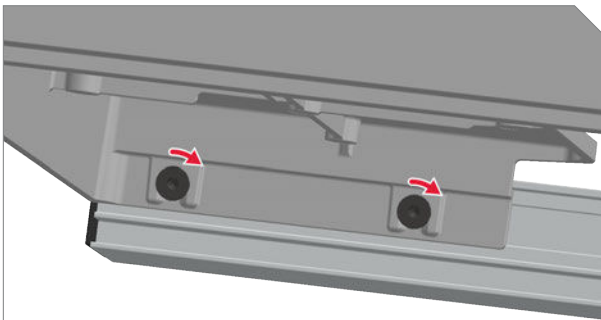

7

Once table top and extension table top are aligned, and the marks are aligned, open extension table and tighten screws.



PROBLEM	POSSIBLE CAUSE(S)	SOLUTION
<b>The motor will not start and both status lights on the switch box are off.</b>	There is no power to the saw.	Make sure the electrical supply to the saw is on and that the correct voltage is being supplied.
	There is no brake cartridge installed in the saw.	Install the brake cartridge (see page 34).
	The brake cartridge is defective.	Replace the brake cartridge with a new cartridge (see page 34).
<b>The motor will not start: the power switch is on, the red status light on solid, the green status light is off (see page 45).</b>	The brake cartridge is defective.	Replace the brake cartridge with a new cartridge (see page 34).
<b>The motor starts slowly and/or fails to reach full operating speed.</b>	The electrical supply voltage is too low.	Make sure the correct voltage is being supplied to the saw.
	The belt is worn or slipping.	Replace the belt.
<b>The motor stopped unexpectedly during use but the brake did not activate.</b>	The Start/Stop paddle was bumped.	Ensure the Start/Stop paddle is in the OFF position, and then restart the saw.
	The material being cut is overloading the safety detection system (e.g., green or wet wood).	Use a different wood or cut in Bypass Mode (see page 50).
	Electrical power to the system was lost, at least temporarily.	Ensure that the electrical supply to the saw is on and you are using the correct voltage.
	The brake cartridge is defective.	Replace the brake cartridge with a new cartridge (see page 34).

PROBLEM	POSSIBLE CAUSE(S)	SOLUTION
<b>Cannot turn the saw on in Bypass Mode.</b>	The sequence for starting the saw in Bypass Mode was not completed.	Follow the steps for starting the saw in Bypass Mode ( <a href="#">see page 50</a> ).
	The Bypass Lockout Key is not fully seated.	Insert the Bypass key fully.
<b>The brake activated, even though there was no accidental contact.</b>	An electrically conductive material contacted the blade, arbor or arbor pulley.	Make sure no metal or other conductive material is touching the blade, arbor or pulley. Use Bypass Mode to cut conductive materials ( <a href="#">see page 50</a> ).
	The spreader or riving knife came into contact with the blade.	Ensure that the spreader or riving knife is aligned and securely clamped in place. There should be a gap of 4-8 mm between the blade and the spreader or riving knife ( <a href="#">see page 70</a> ).
	The blade made contact with the brake pawl.	Make sure there is a gap of 1.5 mm to 3 mm between the teeth of the blade and closest point on the brake cartridge. Use only a 10" blade with a standard brake cartridge.
<b>The blade hits the brake pawl during installation.</b>	The blade is the wrong size.	Use only a 10" blade with a standard brake cartridge.
<b>Cannot install the cartridge key.</b>	The key is not rotated properly to align with the keyhole in the cartridge.	Rotate the key so that the handle is pointing directly toward the brake pawl.
	The shaft of the cartridge key is binding in the cartridge or on the cartridge bracket.	Try installing the key while pressing upward or downward on the key or cartridge.

PROBLEM	POSSIBLE CAUSE(S)	SOLUTION
<b>Raising or lowering the blade feels or sounds rough.</b>	The alignment block is worn, damaged or needs lubrication. The elevation rail is dirty and needs lubrication.	Clean components and re-grease.
	The backdrive prevention assembly is worn.	Contact SawStop Service ( <a href="#">see page 6</a> ).
<b>The saw does not make accurate bevel cuts.</b>	The tilt limit stops are not adjusted properly.	Adjust the tilt limit stops.
	The tilt angle indicator is not adjusted properly.	Adjust the tilt angle indicator.
<b>Cannot remove the brake cartridge.</b>	The cartridge key is still installed.	Remove the cartridge key.
	The cartridge is bound up on the pivot pin and the positioning pin.	Pry the cartridge off the pins with a blade wrench ( <a href="#">see page 36</a> ).
<b>Cannot install the brake cartridge.</b>	The holes in the brake cartridge shell are not aligned with the pivot pin and positioning pin.	Make sure the mounting holes in the brake cartridge are aligned with the pivot and positioning pins.
	There is debris on the pivot or positioning pins, or in the cartridge mounting holes.	Make sure the pins and mounting holes are clean and free of obstructions.
	The blade is interfering with the brake pawl.	Use only a 10" blade with a standard brake cartridge.
<b>Cannot remove the cartridge key.</b>	The cartridge key is not turned to the UNLOCKED position.	Turn the key clockwise until it stops.
	The shaft of the cartridge key is binding in the cartridge or on the cartridge mounting bracket.	Try turning and removing the key while pressing upward or downward on the key or cartridge.

If you have further questions and need more information, Contact SawStop Service ([see page 6](#)).



## DIMENSIONS



Weight (Saw Only)	84 lbs
Weight (With Cart)	113 lbs
Blade Diameter	10"
Dado Diameter	8"
Max. Depth of Cut, Blade at 0°	3 1/8"
Max. Depth of Cut, Blade at 45°	2 1/8"

Max. Rip Right of Blade (Extended)	25 1/2"
Saw Dimensions (with Open Cart) (H x W x D)	36" x 48" x 29"
Saw Dimensions (with Closed Cart) (H x W x D)	26 1/2" x 45" x 29"
Table Dimensions (Extended)	43 5/16" x 24 5/8"

# ELECTRICAL CONNECTION

- Saw must be connected to grounded wiring system or system having an equipment grounding conductor.
- Plug must match outlet that is properly installed and grounded in accordance with all local codes and ordinances.
- Do not modify plug – if it will not fit the outlet, have proper outlet installed by qualified electrician.
- Improper connection of equipment-grounding conductor can result in risk of electric shock and/or malfunction.
- Outer surface of insulation on equipment-grounding conductor is green with or without yellow stripes.
- Check with qualified electrician or service personnel if grounding instructions not understood, or if you are not sure whether saw is properly grounded.
- Do not expose saw to wet or damp conditions.
- Keep power cord away from anything that could damage cord (e.g., heat, sharp objects, etc.).
- Use only 3-wire extension cords with 3-prong grounding plugs and 3-pole receptacles that accept saw's plug.
- Do not use a damaged or worn cord.
- Match size of cord to length needed. An undersized cord will cause drop in line voltage, resulting in loss of power and overheating.

## JSS-120A60

Saw is intended for use on a 110-120 V supply circuit with an outlet that looks like the following example.

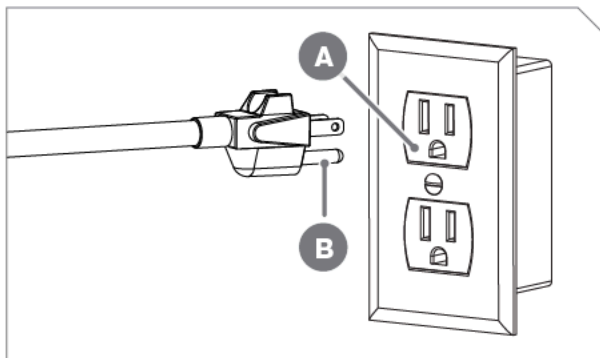

- A. Grounded Outlet
- B. Ground Pin

POWER	
PARAMETER	SPECIFICATION
Motor Configuration	120 V AC 60 Hz, Univ.
Amperage	15 A
Power	2,000 W
Arbor No Load Speed	4,000 RPM

EXTENSION CORD RECOMMENDATIONS	
LENGTH	GAUGE
0-25 Feet	12 AWG
25-50 Feet	10 AWG
Over 50 Feet	Not Recommended

A temporary adapter, which looks like the following illustration, may be used to connect this plug to a 2 pole receptacle as shown below, if a properly grounded outlet is not available. The temporary adapter should be used only until a properly grounded outlet can be installed by a qualified electrician. This adapter is not permitted in Canada. The green-colored rigid ear, lug, and the like, extending from the adapter must be connected to a permanent ground such as a properly grounded outlet box.

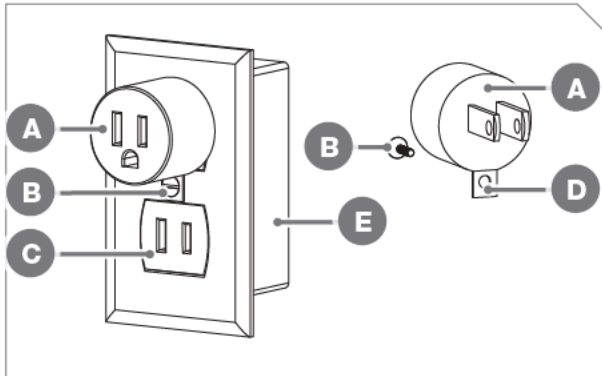

- A. Adapter
- B. Metal Screw
- C. Ungrounded/Unpolarized Outlet
- D. Grounding Lug/Tab
- E. Grounded Outlet Box

## JSS-230A50I

Saw is intended for use on a 230 V supply circuit with an outlet that looks like the following example.

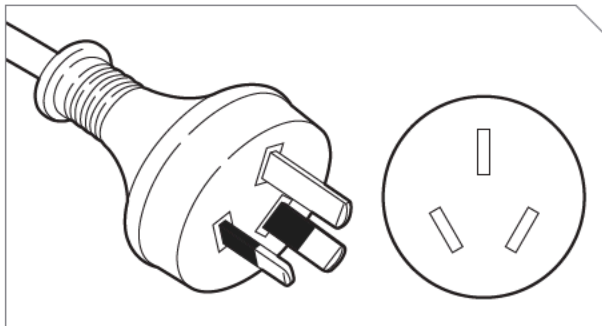

POWER	
PARAMETER	SPECIFICATION
Motor Configuration	230 V AC 50 Hz, Univ.
Amperage	10 A
Power	2,100 W
Arbor No Load Speed	4,000 RPM

EXTENSION CORD RECOMMENDATIONS	
LENGTH	GAUGE
0-25 Feet	14 AWG
25-50 Feet	12 AWG
50-75 Feet	10 AWG
Over 75 Feet	Not Recommended

# CUT SLOT IN ZERO-CLEARANCE INSERT

The blade slot in original insert is pre-cut at factory. However, you must cut a slot in any replacement inserts.

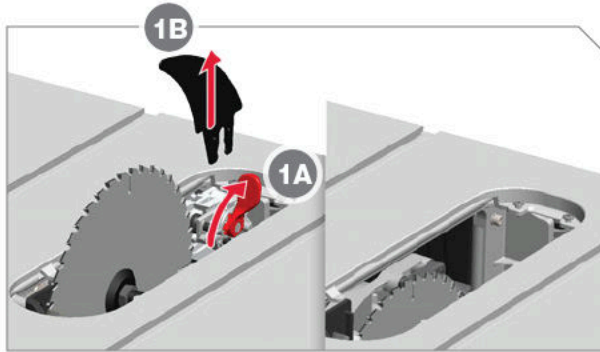

**You must remove the riving knife before cutting the zero-clearance slot.**

**1**

Rotate the clamp handle (1A), and then remove riving knife/blade guard (1B). Lower blade fully and adjust tilt angle to zero degrees.

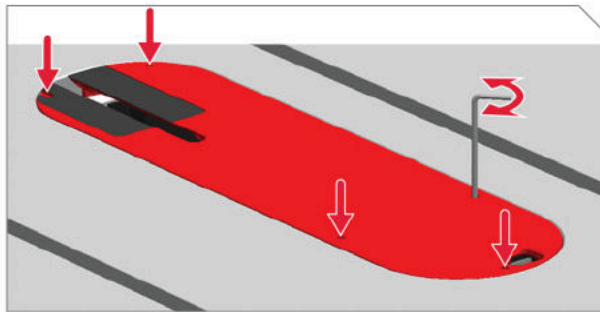

**2**

Install new table insert. Adjust leveling screws until table insert is level and slightly below table ([see page 54](#)).

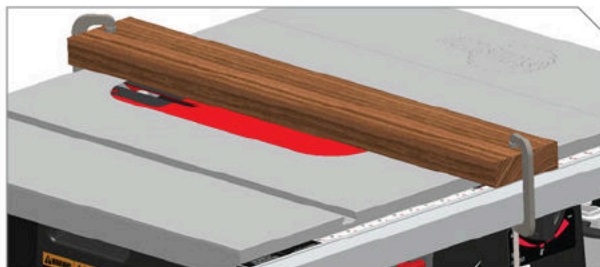

**3**

Clamp a thick piece of wood across right side of table insert to securely hold table insert to table.

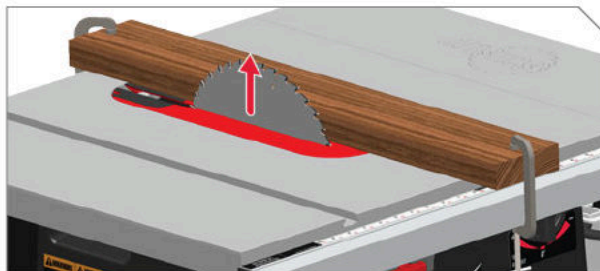

**4**

Start motor and slowly raise blade ([see page 38](#)) to its highest elevation. This will create the slot for cuts at zero degrees tilt.

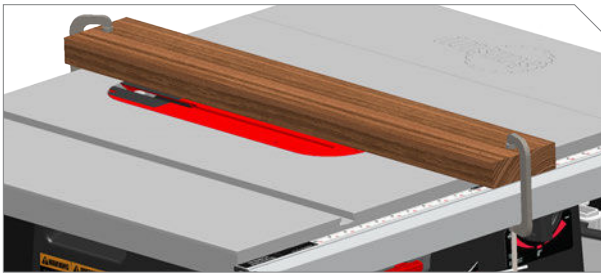

5 Lower blade to lowest elevation and turn off motor.

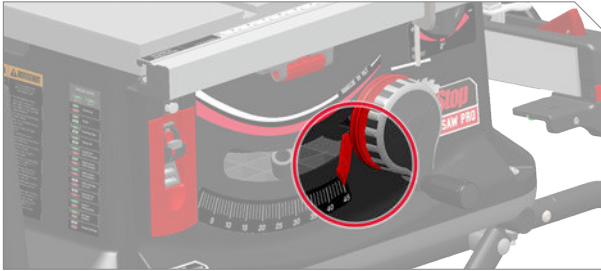

6 Set blade tilt angle to 45 degrees ([see page 38](#)).

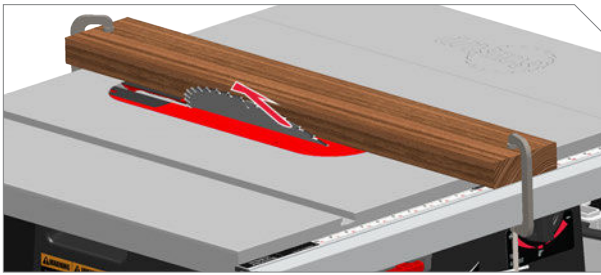





7 Start motor and slowly raise blade to highest elevation. This will widen slot for beveled cuts up to 45 degrees.



8 Stop motor and turn saw off. Remove wood and clamps. Remove table insert and install riving knife or blade guard ([see page 30](#)). Reinstall insert.

# CUTTING OPERATIONS

## SAW BLADE

-  Use the right blade for the job. Use wood-specific saw blades when cutting wood. Use metal-specific saw blades when cutting metal.
-  Do NOT use saw blades that have a lacquer coating on the teeth, blades with depth-limiting shoulders, or blades with non-conductive teeth.
-  Do NOT use saw blades made of materials that are electrically non-conductive (e.g. abrasive blades, blades with plastic hubs, etc.) (see page 19).
-  Turn off the main power switch, remove the lock out key, and then make sure the blade is completely stopped before making any adjustments.
-  Avoid overheating the tips of the saw blade teeth by keeping blade clean and sharp. Ensure dust collection system is clean and free of debris. When cutting plastic, make sure material feed rate does not cause plastic to heat up or melt.

MAXIMUM WORKPIECE DIMENSIONS	
CUT	DIMENSION
Max. Depth of Cut, Blade at 0°	3-1/8"
Max. Depth of Cut, Blade at 45°	2-1/8"
Max. Rip, Right of Blade (Extension Table Retracted)	13-1/2"
Max. Rip, Right of Blade (Extension Table Extended)	25-1/2"
Max. Rip, Left of Blade	9-1/2"

-  To avoid risk of injury, wear gloves when handling saw blades. Never wear gloves when operating the saw.

## MATERIAL REQUIREMENTS

The saw can be used to cut wood, plastic, pliable metal (e.g., aluminum), or other similar materials (see page 47). Do not use the saw to cut ferrous metals. Conductive materials must be cut using Bypass Mode (see page 50). Only use blades with a 10" diameter (8" for Dado blades) and 5/8" bore (arbor) diameter.

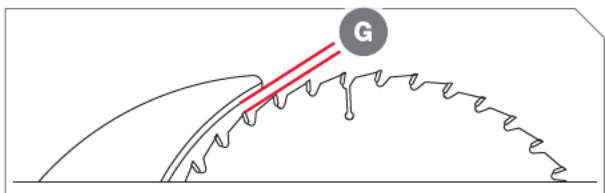
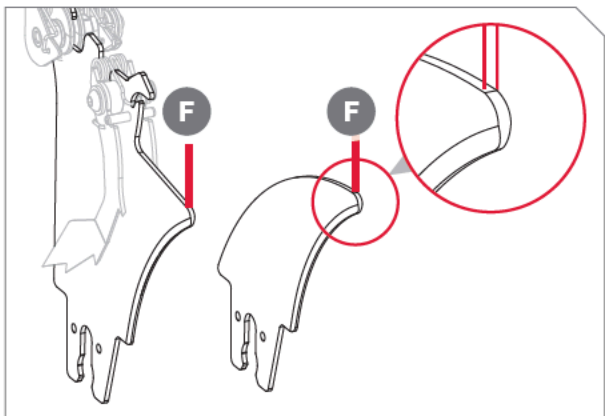
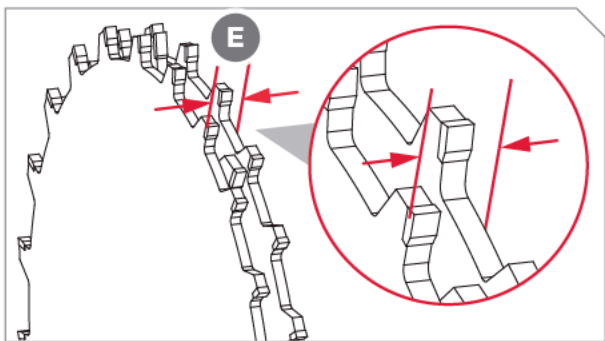
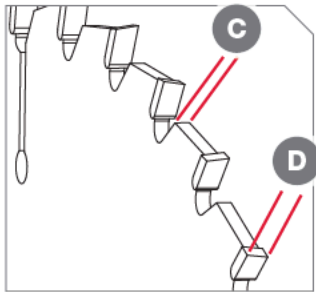
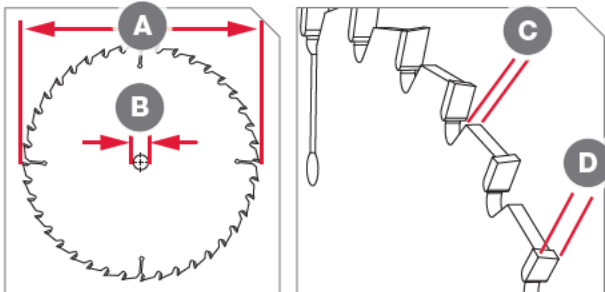

REQUIREMENTS	
Blade Diameter (A)	10"
Bore (Arbor) Diameter (B)	5/8"
Blade Plate Thickness (C)	5/64" (2 mm)
Blade Kerf (D)	3/32" to 3/16" (3 mm)
Blade Diameter (Dado) (A)	8" (Requires a separate brake cartridge and table insert)
Blade Thickness (Dado) (E)	13/16" maximum
Speed	4000 rpm
Riving Knife or Spreader Thickness (F)	0.090" (2.3 mm)
Blade and Riving Knife or Spreader Gap (G)	4-8 mm

**i** Always use a saw blade which is marked with a speed equal to or higher than the speed marked on the Jobsite Saw Pro (4000 rpm).

**i** Both the riving knife and the spreader are 0.090" (2.3 mm) thick. Do NOT use a blade with a kerf less than 3/32" with these tools. When the blade and riving knife or spreader are installed in the saw, there should be a gap of 4-8 mm between the blade and the riving knife or spreader.

## AUXILIARY FENCE AND PUSH BLOCK

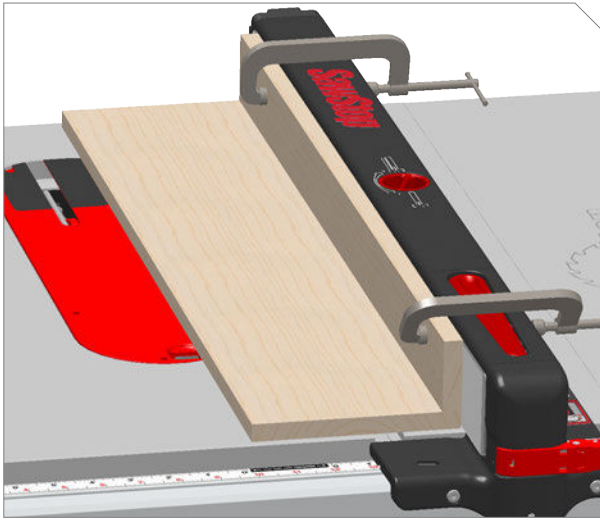

- 1 If a cut is too narrow to use a push stick, use an auxiliary fence (see page 96) and push block (see page 97).

Clamp auxiliary fence to fence using two C-clamps.

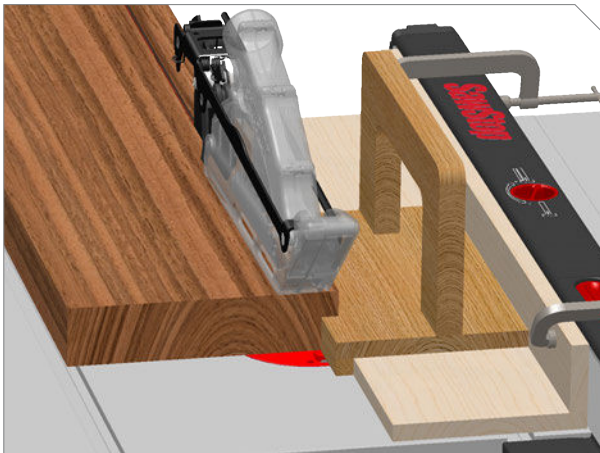

- 2 Slide workpiece along auxiliary fence. When your hand comes within 6" (150 mm) of blade, use a push block to finish cut.

## FEATHERBOARD

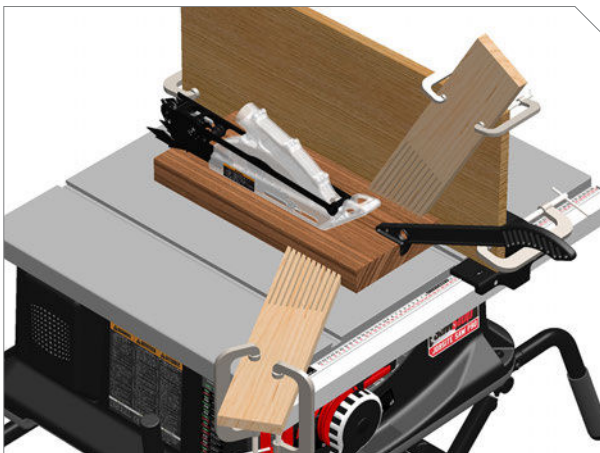

- 1 When using a push stick to feed the workpiece, you can use featherboards to maintain the position of the workpiece relative to the fence and table.

Clamp a featherboard to the top of the table, against the side of the workpiece opposite the fence, to hold the workpiece flush against the fence.

You can also clamp a featherboard to the fence to hold the workpiece down against table surface.



To avoid risk of kickback, make sure the horizontal featherboard is mounted in front of the leading edge of the blade.

# MITER GAUGE



1

Slide the miter gauge into either miter slot in table top.

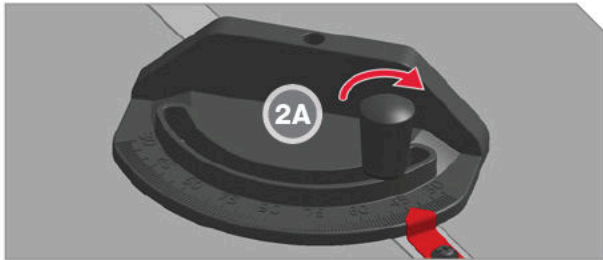

2

To adjust miter gauge angle, turn lock knob counter-clockwise, and then pivot miter gauge head until red pointer is above desired angle (+/- 60°). Tighten lock knob by turning it clockwise (2A) before making cut.



i

Miter gauge may be stored in accessory drawer when not in use.

## ADJUST MITER GAUGE

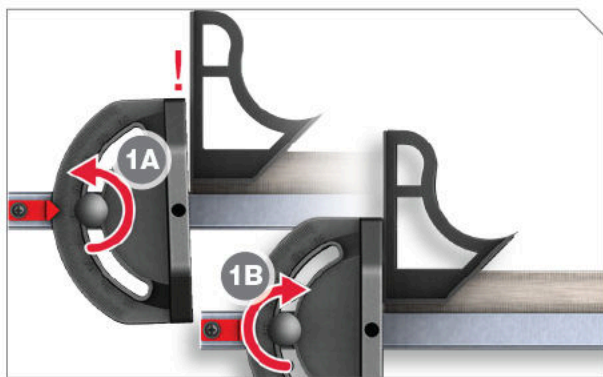

1

Loosen handle (1A). Use a combination square to ensure that bar and gauge are perpendicular. Tighten handle to lock head (1B). Recheck alignment and make further adjustment as necessary.

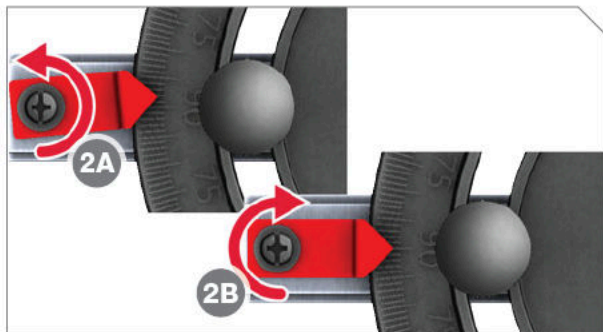

2

Check that the angle marker is set at 90 degrees. If adjustment is needed, use a Phillips head screwdriver to loosen screw (2A), adjust angle marker to 90 degrees (2B), and re-tighten screw.

## MITER GAUGE EXTENSION

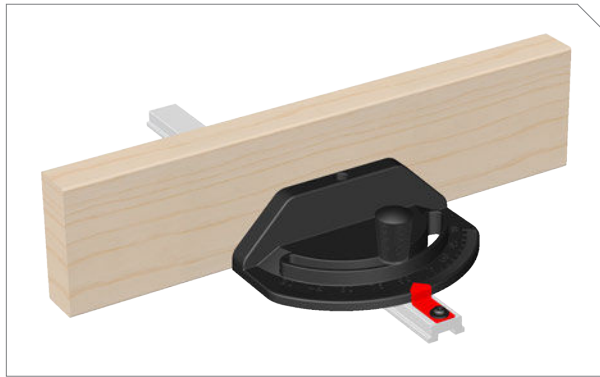
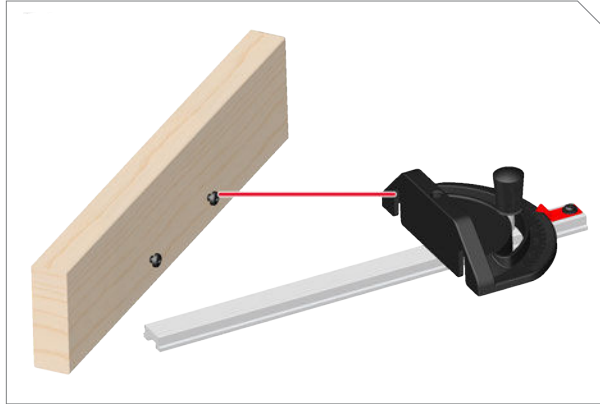

You can mount an optional wooden extension to the miter gauge face to provide additional support for workpieces. To mount the extension, use wood screws with shanks sized to fit through the slots in the miter gauge head. The wood face should be at least 1" (2.5 cm) higher than the maximum depth of cut, and should extend beyond the edges of the miter gauge head.



To reduce the potential for kickback and serious injury, move the fence out of contact with the workpiece when cross-cutting to prevent the workpiece from binding between the fence and the blade.

# CUT TYPES

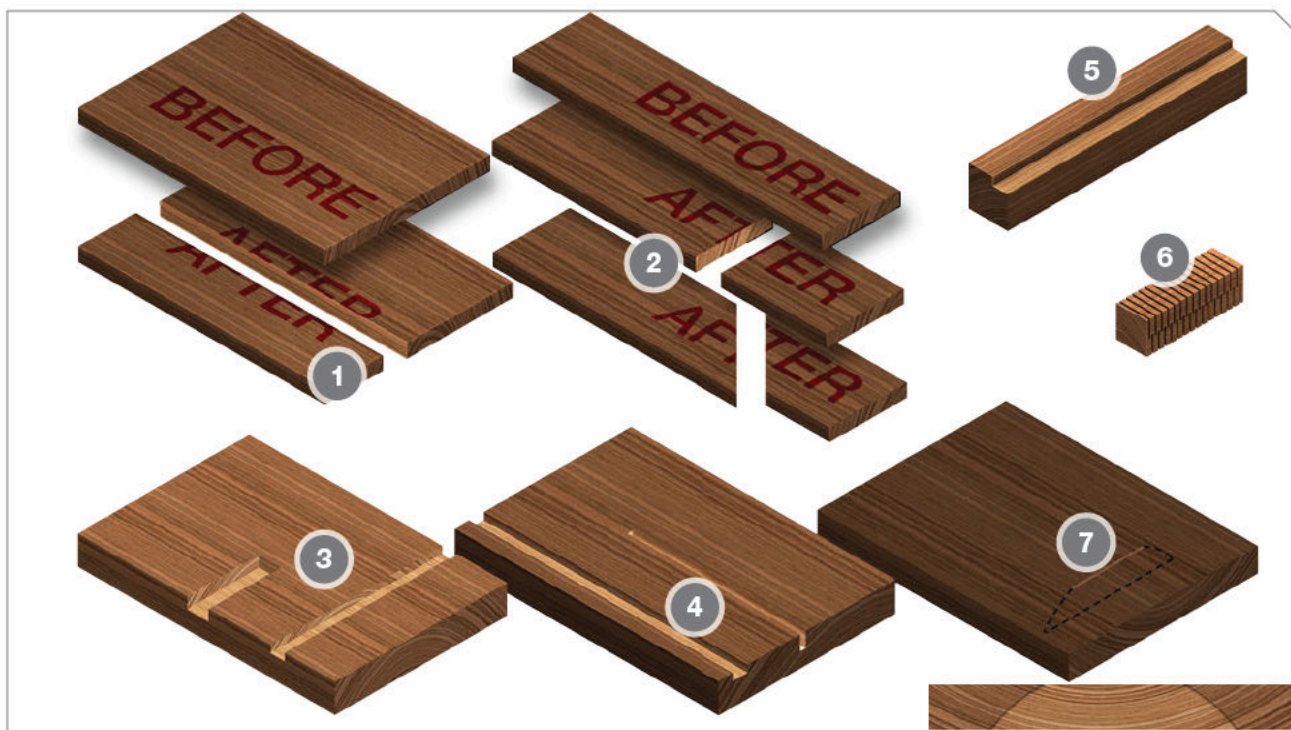

CUT TYPE	DEFINITION	PAGE
Through (e.g. callout 1)	You cut through the entire thickness of the workpiece.	N/A
Rip (1)	You cut with the grain (parallel to) the grain of the workpiece.	75
Non-Through	The blade does not cut through top of wood.	76
Cross (2)	You cut perpendicular to or across the grain of workpiece.	77
Dado (3)	A non-through cut, that you make with special blades, and produces a rectangular-sided slot in workpiece. Can be a through-Dado or stopped Dado.	78
Groove (4)	Like a Dado cut but you cut parallel to the grain.	79
Rabbet (5)	A non-through cut, where you create a rectangular notch along the length of workpiece.	80
Grooving (6)	When you make spaced or repeated cuts, on one or both sides of workpiece, to remove material so the workpiece can flex.	81
Plunge (7)	When you start a cut somewhere other than edge of workpiece.	82

**!** Molding head cutting is not permitted. Tapered cuts are permissible, but are only to be performed with the proper fixture.

## RIP CUT



Rip-cutting (cutting with the grain of the workpiece), must be performed with a fence to support and guide the workpiece.



- 1 Tilt blade to desired bevel angle and adjust blade elevation to about 1/8" to 1/4" (3 to 6 mm) higher than workpiece.
- 2 Position fence (or low fence) at desired rip width and lock in place. Position workpiece flat on table and flush against fence.
- 3 **Make sure workpiece is not touching the blade.** Turn on motor. Use both hands to push workpiece slowly and smoothly toward and past blade.



**Make sure workpiece is not touching blade when starting motor.**



- 4 When cutting long material, ensure adequate support so workpiece does not move or shift as it moves past table edge.  
  
Use a push stick if your hand comes within 6" (150 mm) of blade. The saw comes with a push stick but you can also make one ([see page 94](#)).



**Do NOT use the miter gauge when making rip cuts.**



**The blade guard should be used for all through cuts.**

## NON-THROUGH CUT



A non-through cut does not extend through the entire thickness of the workpiece. In this case you cannot use the blade guard and splitter but must use the riving knife instead.

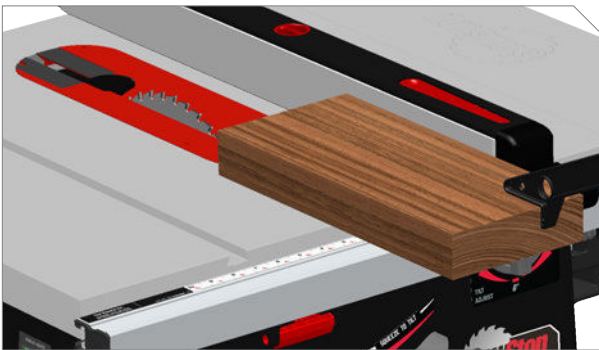

1

Remove the blade guard and install the riving knife ([see page 33](#)). If the non-through cut is a rip cut use the fence.



## CROSS CUT



Cross-cutting (cutting perpendicular to the grain of the workpiece) is performed using a miter gauge. The miter angle is indicated by the scale below the pointer.

- 1 Tilt blade to desired bevel angle and adjust blade elevation to about 1/8" to 1/4" (3 to 6 mm) higher than workpiece.
- 2 Place miter gauge in right miter slot for bevel cuts, or in either right or left miter slot for non-bevel cuts.
- 3 Adjust miter gauge to desired miter angle (see page 72).

4 **Make sure workpiece is not touching the blade.** Turn on motor.

5 Hold workpiece squarely and firmly against miter gauge face and table. Push workpiece slowly and smoothly toward and past blade.

6 For through-cuts, shift workpiece slightly away from blade before pulling miter gauge and workpiece back toward front of saw. Do NOT touch cut-off portion of workpiece until blade has stopped.

 Molding Head cutting is not permitted.

 Tapered cuts are permissible, but are only to be performed with the proper fixture.

 Do not use the miter gauge in the slot on the left of the blade when making bevel cuts.

 To reduce the risk of kickback and serious injury when cross-cutting, move the rip fence out of contact with the workpiece, or remove it from the table entirely, to prevent the workpiece from binding between the rip fence and the blade.

## DADO CUT



Dado cuts are used to create a slot or trench in the surface of the workpiece. A Dado is cut perpendicular to the grain of the workpiece.



**You must install an 8" Dado blade, Dado brake cartridge, and Dado blade table insert in order to perform Dado cuts.**



**Wobble Dado blade setups are NOT compatible with the Jobsite Saw Pro.**



**Extra caution is needed when making Dado cuts, since the blade guard, riving knife, and anti-kickback pawls cannot be used.**



1

Adjust blade elevation to desired cut depth. Move fence well away from the workpiece or remove fence from the table.

2

Position workpiece flat on table and flush against miter gauge. **Make sure workpiece is not touching the blade.** Turn on motor.

i

Use of a featherboard to hold the workpiece down is recommended to help prevent kickback.

3

Hold workpiece squarely and firmly against miter gauge face and table. Push workpiece slowly and smoothly toward and past blade.

i

For more detailed information on Dado setup or cutting operation, visit the Woodworker's Guild of America website at: [www.wwgoa.com/article/make-better-dadoes-on-the-table-saw/](http://www.wwgoa.com/article/make-better-dadoes-on-the-table-saw/)

## GROOVE CUT



Groove cuts are like Dado cuts and used to create a slot or trench in the surface of the workpiece. However, unlike Dado cuts, a groove is cut parallel to the grain of the workpiece.



1

Adjust blade elevation to desired cut depth. Position fence at desired width and lock in place.

2

Position workpiece flat on table and flush against fence. **Make sure workpiece is not touching the blade.** Turn on motor.

i

Use of a featherboard to hold the workpiece down is recommended to help prevent kickback.

3

Use a push block to safely cut workpiece.

## RABBET CUT



A rabbet cut is used to create a rectangular notch along the edge of a workpiece.

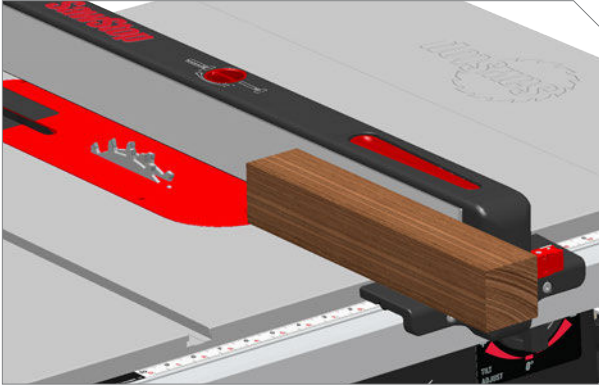

1

Remove blade guard and spreader.

2

Adjust blade elevation to desired cut depth. Position fence at desired width and lock in place.

3

Position workpiece flat on table and flush against fence. **Make sure workpiece is not touching the blade.** Turn on motor.

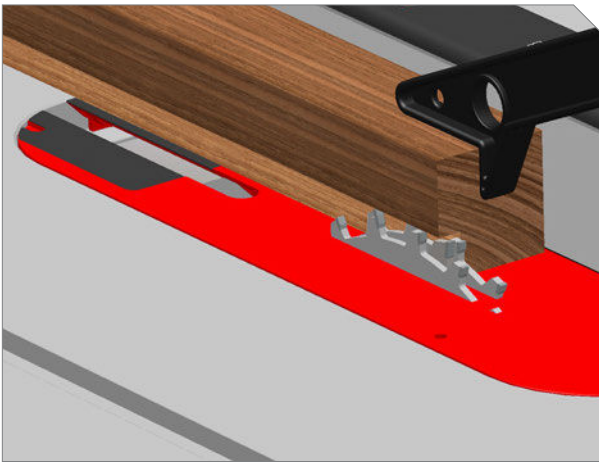

4

Use a push block or push stick to safely cut workpiece. Turn off motor.

## GROOVING CUT

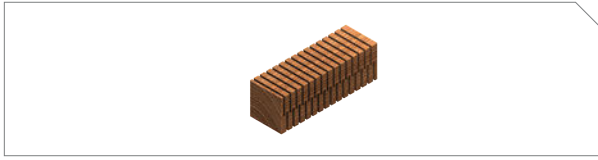

Grooving removes areas of material so a workpiece can be bent or shaped.

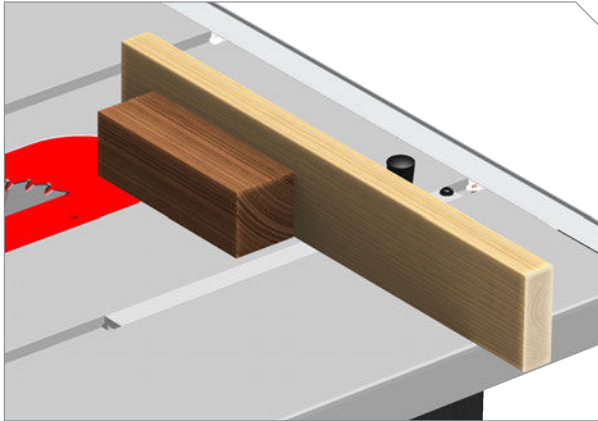

1 Adjust blade elevation to the desired grooving depth.

2 Mount a wood face extension to miter gauge (see page 72). Install miter gauge in miter slot, making sure wood face extends across blade (so a single cut will be made in the face).

3 Hold workpiece squarely and firmly against miter gauge extension and table. **Make sure workpiece is not touching the blade.** Turn on motor.



4 Make a series of evenly spaced cuts along workpiece, moving workpiece over slightly between each cut.



5 As needed, flip workpiece over and make another series of cuts, offset from first set, using same method.

## PLUNGE CUT



A plunge cut is used to create a slot or opening somewhere other than the edge of the workpiece.



**Extra caution is needed when making plunge cuts, since the blade guard, riving knife, and anti-kickback pawls cannot be used.**



1

Fully lower the blade. Position the fence at the desired cut width and lock in place. Position the workpiece flat on the table and flush against the fence.

2

Clamp the workpiece to the table using clamps and/or featherboards: If the plunge cut will be the start of a longer cut, use featherboards. If the blade will be raised and lowered while the workpiece remains stationary, clamp the workpiece directly to the table.

i

You can clamp a board on top of the workpiece, if it cannot easily be clamped to the table.



3

Turn on motor. Slowly raise blade to desired height (partially into or all the way through workpiece).

4

If making a stationary plunge cut, slowly lower blade and turn off motor.

5

If making a long plunge cut, use a push block or push stick to slowly and smoothly advance workpiece to desired end point of cut. Slowly lower blade and turn off motor.

6

Turn saw off and wait for blade to stop fully before removing workpiece.



To avoid risk of kickback, make sure the horizontal featherboard is mounted in front of the leading edge of the blade.

## OTHER CUT TYPES

### Resawing and Plowing (Cove Cutting)

Resawing is to make two non-through cuts with an ordinary saw blade in the same plane, but on opposite sides of a workpiece.

Plowing (Cove Cutting) is to move a workpiece over an ordinary saw blade utilizing a special fence that is not parallel to the cutting line of the saw blade. Increase the depth of the cut in very small increments after each pass.

# EXPLODED VIEWS AND PARTS LISTS

## TABLE AND FENCE

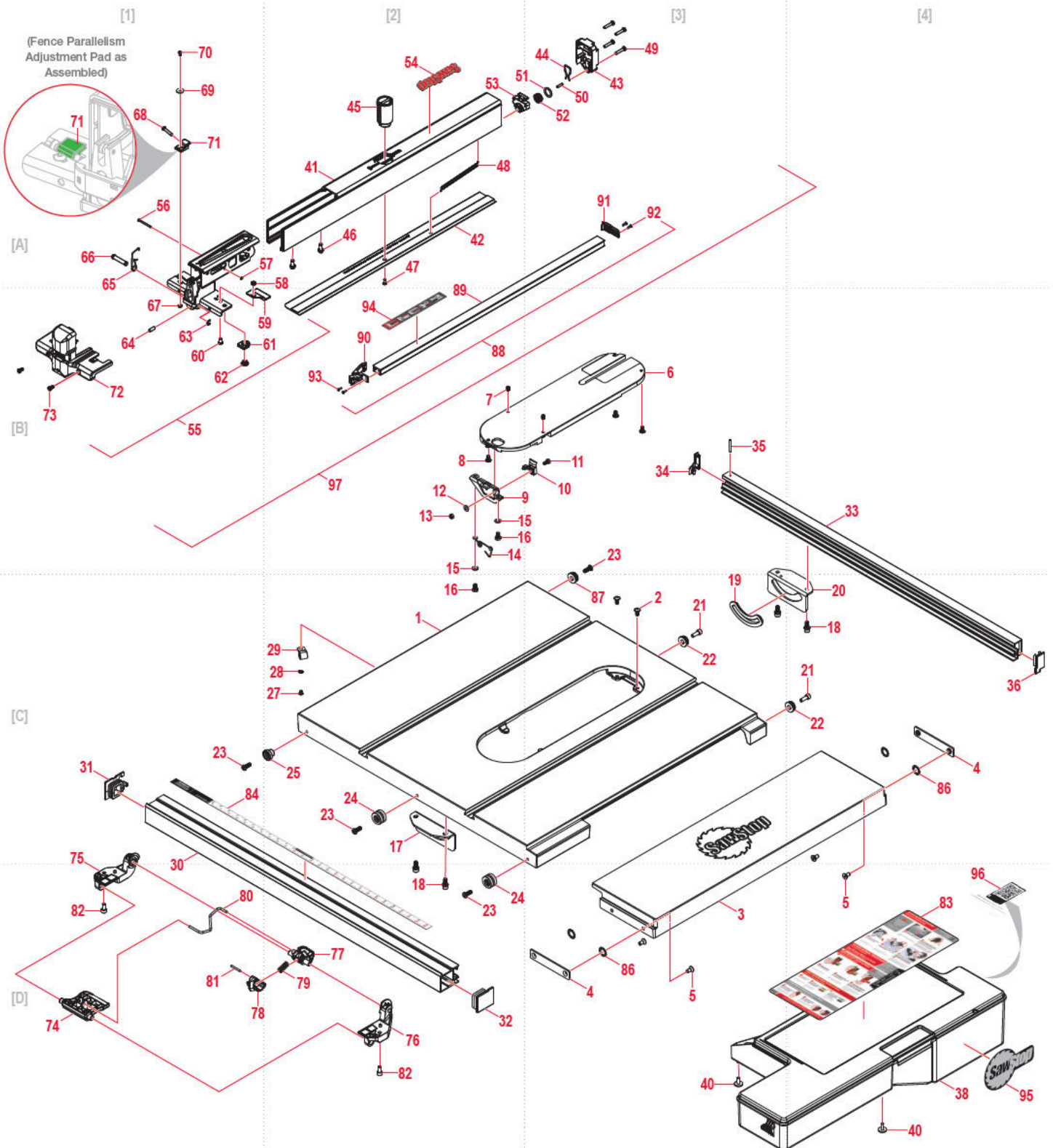

## TABLE AND FENCE PARTS LIST

ITEM	DESCRIPTION	P/N	QTY.
1	Table [c2]	JSS-400	1
2	Rear Lock Down Screw for Insert [c3]	JSS-002	2
3	Extension Wing [p3]	JSS-401	1
4	Rail Clamp Plate [c4] [p3]	JSS-004	2
5	M6x1.0x16 Flat Head Socket Screw [p3] [p4]	JSS-005	4
6	Premium Table Insert (includes items 7 & 8) [B3]	TSI-SJB-P	1
7	M6x1.0x8 Flat Tip Set Screw [B2] [B3]	JSS-007	2
8	M6x1.0x9.5 Insert Leveling Screw [B2] [B3]	JSS-008	3
9	Insert Latch [B2]	JSS-009	1
10	Insert Release Lever [B3]	JSS-010	1
11	M5x0.8x10 hex Head Bolt [B3]	JSS-011	1
12	M5x12x1 Washer [B2]	JSS-012	1
13	M5x0.8 Lock Nut [B2]	JSS-013	1
14	Insert Ejection Spring [B2]	JSS-014	1
15	M6x12x1 Washer [B2]	JSS-015	2
16	M6x1.0x10 hex Head Bolt [B2] [c2]	JSS-016	2
17	Front Trunnion Bracket [c2]	JSS-017	1
18	M6x1.0x16 Socket Head Cap Combination Screw [c3] [c4] [p2]	JSS-018	4
19	Trunnion Guide Bushing [c3]	JSS-019	1
20	Rear Trunnion Bracket [c4]	JSS-020	1
21	M6x1.0x16 Socket Head Cap Screw [c3] [c4]	JSS-021	2
22	Rear Rail Mount Pad [c3] [c4]	JSS-022	2
23	M6x1.0x16 Button Head Socket Screw [B3] [c1] [c2] [p2]	JSS-023	4
24	Front Rail Mount Pad [c2] [p2]	JSS-024	2
25	Left Front Rail Mount Pad [c2]	JSS-025	1
27	M5x0.8x10 Pan Head Phillips Screw [c2]	JSS-027	1
28	M5 External Tooth Lock Washer [c2]	JSS-028	1
29	Table Cable Clamp [c2]	JSS-029	1
	5/16" Cable Clamp (JSS-230A50I) [c2]	JSS-316	
30	Front Rail [c1]	JSS-030	1
31	Left Front Rail End Cap [c1]	JSS-031	1
32	Right Front Rail End Cap [p2]	JSS-032	1
33	Rear Rail [B4]	JSS-033	1
34	Left Rear Rail End Cap [B3]	JSS-034	1
35	Spring Pin (3mm x 28mm) [B3]	JSS-035	1
36	Right Rear Rail End Cap [c4]	JSS-036	1
38	Accessory Storage Assembly [p4]	JSS-404	1
40	M5x1.59x16 Washer Head Phillips Thread Cutting Screw [p3] [p4]	JSS-040	2
41	Fence Tube Service Assembly [A2]	JSS-406	1
42	Support Shelf [A2]	JSS-407	1
43	Fence End Cap [A3]	JSS-408	1
44	End Cap Spring [A3]	JSS-409	1
45	Support Shelf Knob [A2]	JSS-044	1
46	M6x1.0x16 Flange Head Phillips Screw [A2]	JSS-045	2
47	M4x1.41x10 Button Head Phillips Screw [B2]	JSS-046	1
48	Support Shelf Spring [A2]	JSS-047	1
49	M5x1.59x25 Pan Head Phillips Screw [A3]	JSS-048	4
50	Fence Roller Pin (4mm x 16mm) [A3]	JSS-049	1

ITEM	DESCRIPTION	P/N	QTY.
51	16mm O-Ring [A3]	JSS-050	1
52	Fence Roller Wheel [A3]	JSS-051	1
53	Fence Roller Cover [A2]	JSS-410	1
54	SawStop Fence Label [A2]	JSS-053	1
55	Fence Head Assembly (includes items 55-73) [A1] [B1]	JSS-466	1
56	Fence Latch Pivot Pin (5mm x 36mm) [A1]	JSS-055	1
57	3mm E-Style Retaining Ring [A1]	JSS-056	1
58	M6x1.0 Left-Hand Jam Nut [A1]	JSS-057	1
59	Fence Pointer [B1]	JSS-411	1
60	M6x1.0x9.5 Fence Indicator Lens Screw [B1]	JSS-059	1
61	Fence Glide Pad [B1]	JSS-060	1
62	Fence Glide Pad Screw [B1]	JSS-061	1
63	8mm E-Style Retaining Ring [B1]	JSS-062	1
64	M6x1.0x14 Flat Tip Set Screw [B1]	JSS-063	1
65	Fence Latch Spring [A1]	JSS-064	1
66	Grooved Clevis Pin (8mm x 39mm) [A1]	JSS-065	1
67	M5x0.8 Jam Nut [B1]	JSS-066	1
68	M5x0.8x30 Button Head Socket Screw [A1]	JSS-067	1
69	M5x10x2 Washer [A1]	JSS-068	1
70	M5x0.8x10 Button Head Socket Screw [A1]	JSS-069	1
71	Fence Parallelism Adjustment Pad [A1]	JSS-070	1
72	Fence Head Cover [B1]	JSS-412	1
73	M5x0.8x8 Button Head Socket Screw [B1]	JSS-413	2
74	Rail Handle [p1]	JSS-073	1
75	Left Rail Handle Bracket [p1]	JSS-074	1
76	Right Rail Handle Bracket [p2]	JSS-075	1
77	Rail Lock Linkage Cam [p2]	JSS-076	1
78	Rail Lock Clamp Cam [p1]	JSS-077	1
79	Rail Locking Cam Spring [p2]	JSS-078	1
80	Rail Lock Link [p1]	JSS-079	1
81	Dowel Pin (3mm x 25mm) [p1]	JSS-080	1
82	M6x1.0x10 Pan Head Phillips Screw [p1] [p2]	JSS-081	2
83	Storage Drawer Label (included with item 38) [p4]	JSS-476	1
84	Fence Ruler (Inch) [c1]	JSS-414	1
	Fence Ruler (Metric) [c1]	JSS-415	1
86	M12 External Tooth Lock Washer [c4] [p3]	JSS-307	4
87	Rear Left Rail Mount Pad [c3]	JSS-328	1
88	Low Fence Complete Assembly (includes items 89-94) [B2]	JSS-416	1
89	Low Fence Tube Service Assembly [B2]	JSS-417	1
90	Low Fence Front Latch Assembly [B2]	JSS-418	1
91	Low Fence End Catch [A3]	JSS-419	1
92	M3x1.06x12 Button Head Phillips Screw [A3]	JSS-420	2
93	M3x1.06x8 Flat Head Socket Screw [B2]	JSS-421	2
94	Low Fence Label [B2]	JSS-422	1
95	SawStop Label [p4]	JSS-463	1
96	QR Code Label (inside of storage lid) [p4]	JSS-477	1
97	Fence Assembly (includes items 41-94) [B2]	JSS-405	1

Coordinates in square brackets [ ] correspond to the grid in the exploded view.



## CABINET ASSEMBLY PARTS LIST

ITEM	DESCRIPTION	P/N	QTY.
1	Cabinet Base [D2]	JSS-083	1
2	M5x1.59x16 Pan Head Phillips Screw [D2, various]	JSS-084	15
3	Support Foot [C3] [D2] [D3] [D4]	JSS-085	4
4	M5x16x2 Washer [C3] [D2] [D4] [E3]	JSS-086	4
5	M5x1.59x25 Pan Head Phillips Screw [C3] [D2] [D4] [E3]	JSS-087	4
6	Cabinet [B3]	JSS-088	1
7	M8x1.25x90 Button Head Socket Screw [A3] [B2] [B4] [C2]	JSS-089	4
8	M8x20x2 Washer [A3, various] [D3, various]	JSS-090	8
9	M8x1.25 Lock Nut [D3] [E2] [E3] [E4]	JSS-091	4
10	M5x1.59x20 Pan Head Phillips Screw [C3]	JSS-092	2
11	M5x16x2 Washer [B3] [C3]	JSS-093	2
12	Front Fence Storage Bracket [C4]	JSS-424	1
13	Rear Fence Storage Bracket [B4]	JSS-425	1
14	Fence Storage Retainer [B4]	JSS-096	1
15	Fence Storage Spring [B4]	JSS-097	1
16	Fence Storage Lock [B4]	JSS-427	1
17	M5x0.8x16 Socket Head Cap Combination Screw [B3]	JSS-099	2
18	M6x1.0x25 Socket Head Cap Combination Screw [A3] [B2] [B3] [B4]	JSS-100	4
19	Specification Label (JSS-120A60) [A4]	JSS-428	1
	Specification Label (JSS-230A50I) [A4]	JSS-429	
	Specification Label (JSS-120A60A) [A4]	JSS-430	
	Specification Label (JSS-230A50G) [A4]	JSS-431	
20	M4x1.59x16 Pan Head Phillips Screw [B4]	JSS-102	2
21	Power Cord Clamp [A4]	JSS-103	1
	Power Cord Clamp (JSS-230A50I) [A4]	JSS-317	
22	Accessory Storage Plate [A4]	JSS-104	1
23	M5x1.59x12 Flat Head Phillips Screw [A4]	JSS-105	2
24	Accessory Storage Lock [A4]	JSS-106	1
25	Accessory Storage Screw [A4]	JSS-107	1
26	Arbor Flange Wrench [A4]	JSS-108	1
27	Arbor Nut Wrench [A4]	JSS-109	1
28	Patent Label [A3]	JSS-110	1
29	Accessory Storage Spring [A3]	JSS-111	1
30	M4x14x1 Washer [A3]	JSS-112	2

ITEM	DESCRIPTION	P/N	QTY.
31	Storage Lock Spring [A3]	JSS-113	1
32	M4x0.7 Lock Nut [A3]	JSS-114	1
33	9.2mm Cable Clamp [B2] [B3]	JSS-115	3
	9.2mm Cable Clamp (JSS-230A50I) [B2] [B3]	JSS-115	1
	6.3mm Cable Clamp (JSS-230A50I) [B2] [B3]	JSS-327	2
34	M5x1.59x12 Pan Head Phillips Screw [A1] [B2] [B3]	JSS-116	4
35	Motor Cover [A1]	JSS-117	1
36	M5x16x1 Washer [A1]	JSS-118	1
37	Main Warning Label [A1]	JSS-119	1
38	System Status Label [B1]	JSS-120	1
39	Cable Tie [B1]	JSS-121	1
40	120VAC Power Cord [B1]	JSS-122	1
	230VAC Power Cable (JSS-230A50I) [B1]	JSS-309	
	230VAC Power Cable (JSS-230A50G) [B1]	JSS-326	
41	M5x1.59x30 Pan Head Phillips Screw [B1]	JSS-123	4
42	Switch Box Back Assembly (JSS-120A60 ONLY) [C1]	JSS-124	1
43	Switch Box Front Assembly [C1]	JSS-125	1
N/A	Switch Box Assembly (JSS-230A50I)	JSS-319	1
N/A	Switch Box Assembly (JSS-230A50G)	JSS-325	1
44	Bypass Key [C1]	JSS-126	1
45	Angle Ruler Label [C2]	JSS-127	1
46	Squeeze to Tilt Label [B2]	JSS-460	1
47	Jobsite Saw Pro Label [C2]	JSS-461	1
48	MicroAdjust Tilt Knob [C1]	JSS-456	1
49	MicroAdjust Tilt Arm [C3]	JSS-131	1
50	Spring Pin (2mm x 22mm) [C3]	JSS-132	1
51	M6x45x2 Washer [C3]	JSS-133	1
52	MicroAdjust Knob Spacer [C3]	JSS-134	1
53	M6x1.0x35 Socket Head Cap Screw [C4]	JSS-135	1
54	Tilt Adjust Label [C2]	JSS-459	1
55	Switch Box Lock Out Key [B1]	JSS-464	1
N/A	EMC Filter (JSS-230A50I)	JSS-310	1
N/A	Power Cord Velcro Tie (JSS-230A50I)	JSS-315	1
56	Contact Detection Label [B2]	JSS-462	1

Coordinates in square brackets [ ] correspond to the grid in the exploded view.

# INTERNAL ASSEMBLY

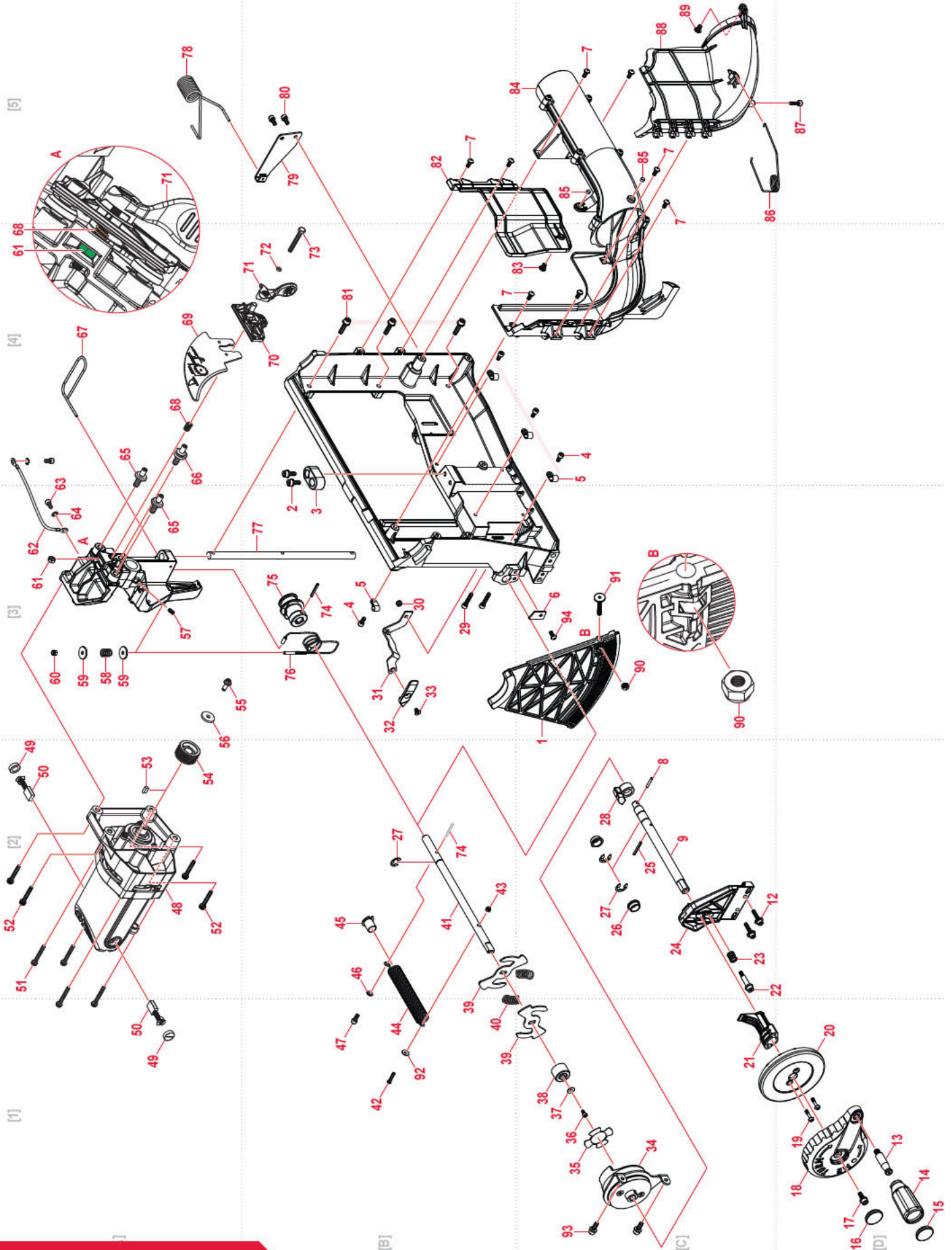

## INTERNAL ASSEMBLY PARTS LIST

ITEM	DESCRIPTION	P/N	QTY.
1	Tilt Angle Rack [c3]	JSS-137	1
2	M6x1.0x16 Socket Head Cap Combination Screw [B4]	JSS-138	2
3	Arbor Bumper [B4]	JSS-139	1
4	M5x0.8x10 Socket Head Cap Screw [B3] [C4]	JSS-140	4
5	6.3mm Cable Clamp [B3] [C3]	JSS-141	4
6	Tilt Rack Retaining Bracket [c3]	JSS-142	1
7	M5x0.8x12 Button Head Socket Combination Screw [B5] [C4] [C5]	JSS-143	8
8	Spring Pin (3mm x 20mm) [c2]	JSS-144	1
9	Elevation Input Shaft [c2]	JSS-145	1
12	M5x0.8x25 Socket Head Cap Combination Screw [c2]	JSS-148	2
13	Handwheel Handle Post [D1]	JSS-149	1
14	Handwheel Handle [D1]	JSS-150	1
15	Handwheel Cap [D1]	JSS-151	1
16	Handwheel Cap [D1]	JSS-152	1
17	M6x1.0x16 Socket Head Cap Combination Screw [D1]	JSS-153	1
18	Handwheel [D1]	JSS-154	1
19	M5x1.59x16 Pan Head Phillips Screw [D1]	JSS-155	2
20	Tilt Lock Handle [D1]	JSS-156	1
21	Tilt Lock Sleeve [c1]	JSS-157	1
22	M5x0.8 Socket Head Shoulder Screw (7mm x 23mm) [c2]	JSS-158	1
23	Tilt Locking Spring [c2]	JSS-159	1
24	Tilt Locking Plate [c2]	JSS-160	1
25	Spring Pin (5mm x 28mm) [c2]	JSS-161	1
26	Bushing (14mm x 17mm x 6mm) [c2]	JSS-162	2
27	14mm E-Style Retaining Ring [B2] [c2]	JSS-163	3
28	Elevation Limit Collar [c2]	JSS-164	1
29	M5x0.8x25 Socket Head Cap Screw [B3]	JSS-165	2
30	M5x0.8 Lock Nut [B3]	JSS-166	1
31	Tilt Indicator Bracket [B3]	JSS-167	1
32	Tilt Indicator [B3]	JSS-168	1
33	M5x0.8x8 Red Flat Head Socket Screw [B3]	JSS-169	1
34	Backdrive Prevention Assembly [c1]	JSS-170	1
35	Coupler Seal [c1]	JSS-171	1
36	M4x0.7x8 Socket Head Cap Screw [c1]	JSS-172	1
37	M4x10x1 Washer [c1]	JSS-173	1
38	Elevation Control Shaft Coupler [c1]	JSS-174	1
39	Shock Spring Mounting Plate [B2] [c1]	JSS-175	2
40	Shock Compression Spring [B1] [c2]	JSS-176	2
41	Elevation Control Shaft [B2]	JSS-177	1
42	M4x0.7x20 Button Head Socket Screw [B1]	JSS-178	1
43	M4x0.7 Lock Nut [B2]	JSS-179	1
44	Elevation Balance Spring [B1]	JSS-180	1
45	Elevation Spring Bushing [B2]	JSS-181	1
46	M5x10x1 Washer [B2]	JSS-182	1
47	M5x0.8x12 Button Head Socket Screw [B1]	JSS-183	1
48	120V, 60Hz Motor (JSS-120A60 and JSS-120A60A) [A2]	JSS-184	1
	230V, 50Hz Motor (JSS-230A50I) [A2]	JSS-311	1
49	Motor Brush Cap [A1] [A2]	JSS-185	2

ITEM	DESCRIPTION	P/N	QTY.
50	Motor Brush [A1] [A2]	JSS-186	2
51	M5x0.8x35 Pan Head Phillips Combination Screw [A2]	JSS-187	4
52	M6x1.0x25 Socket Head Cap Combination Screw [A2]	JSS-188	4
53	M5x5x12 Key [A2]	JSS-189	1
54	Motor Pulley [A2]	JSS-190	1
55	M6x1.0x16 Flange Head Phillips Screw [A3]	JSS-191	1
56	M6x23x3 Washer [A3]	JSS-192	1
57	M5x0.8x12 Set Screw [A3]	JSS-193	1
58	Cable Tensioning Spring [A3]	JSS-194	1
59	M5x16x3 Washer [A3]	JSS-195	2
60	M5x0.8 Lock Nut [A3]	JSS-196	1
61	M6x1.0 hex Nut [A3]	JSS-197	1
62	Trunnion Grounding Wire [A3]	JSS-198	1
63	M5x0.8x10 Socket Head Cap Screw [A3] [A4]	JSS-199	2
64	M5 External Tooth Lock Washer [A3] [A4]	JSS-200	2
65	Spreader Mounting Pin [A3]	JSS-201	2
66	Spreader Locating Pin [A4]	JSS-202	1
67	Shipping Pin [A4]	JSS-203	1
68	Spreader Clamp Spring [A4]	JSS-204	1
69	Riving Knife (10" Blade) [A4]	JSS-442	1
	Riving Knife (250 mm Blade) [A4]	JSS-443	1
70	Spreader Clamp Plate [B4]	JSS-206	1
71	Spreader Clamp Handle [B4]	JSS-207	1
72	M6 Polyurethane O-Ring [B4]	JSS-208	1
73	M6x1.0x45 hex Head Bolt [B4]	JSS-209	1
74	Spring Pin (3mm x 28mm) [B3]	JSS-210	1
75	Elevation Control Pulley [B3]	JSS-211	1
76	Elevation Cable [B3]	JSS-212	1
77	Elevation Shaft [B3]	JSS-465	1
78	Counterbalance Spring [A5]	JSS-214	1
79	Counterbalance Spring Bracket [B5]	JSS-215	1
80	M5x0.8x12 Socket Head Cap Combination Screw [B5]	JSS-216	2
81	M6x1.0x25 Socket Head Cap Combination Screw [B4]	JSS-217	3
82	Rear Blade Shroud [B5]	JSS-218	1
83	M6x1.0x9.5 Insert Leveling Screw [C4]	JSS-219	1
84	Dust Shroud Base [C5]	JSS-220	1
85	Dust Shroud Magnet [C5]	JSS-221	2
86	Dust Shroud Door Spring [C5]	JSS-222	1
87	M5x0.8x16 Socket Head Cap Screw [D5]	JSS-223	1
88	Dust Shroud Door [C5]	JSS-224	1
89	M6x1.0x9.5 Insert Leveling Screw [C5]	JSS-225	1
90	M6x1.0 Lock Nut [C3]	JSS-226	1
91	Tilt Angle Rack Adjustment Screw [C3]	JSS-227	1
92	M4x10x1 Washer [B1]	JSS-228	1
93	M6x1.0x16 Socket Head Cap Combination Screw [C1]	JSS-229	2
94	M5x0.8x12 Button Head Socket Combination Screw [C3]	JSS-230	1

Coordinates in square brackets [ ] correspond to the grid in the exploded view.

# ARBOR ASSEMBLY

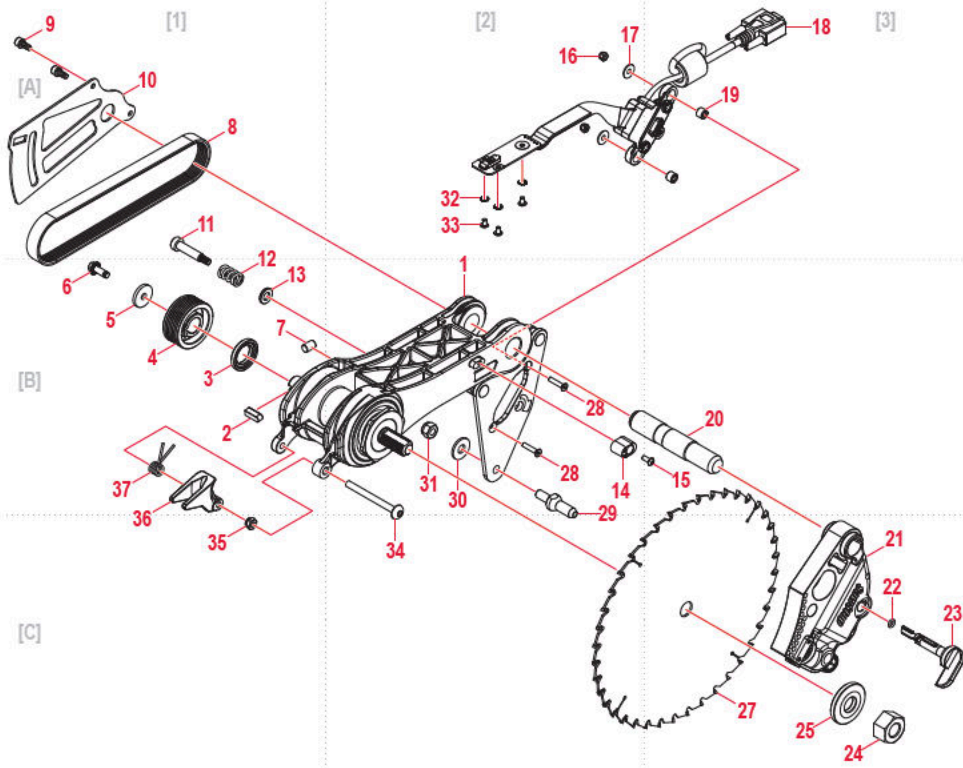

# BLADE GUARD AND MITER GAUGE ASSEMBLY

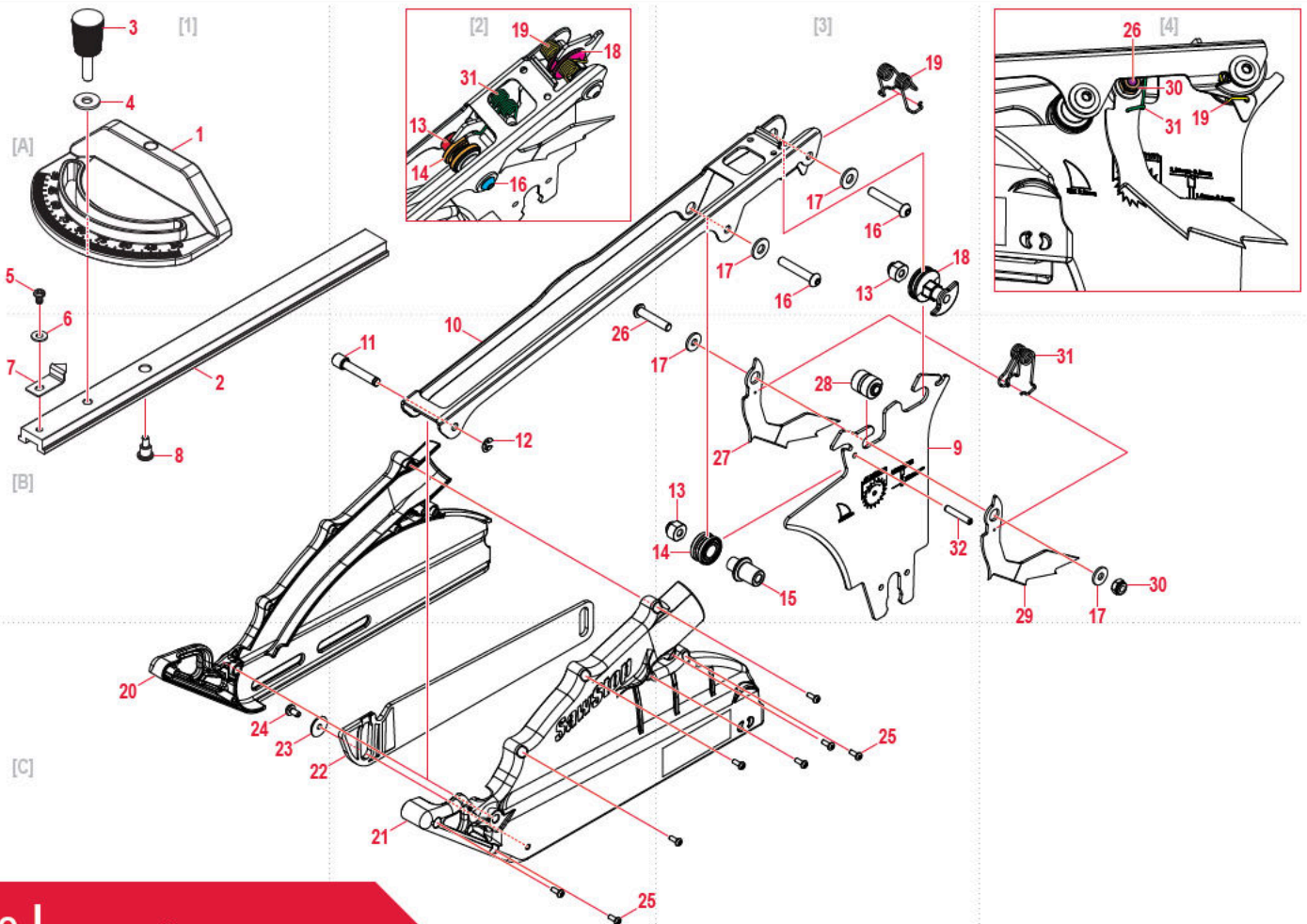

## ARBOR ASSEMBLY PARTS LIST

ITEM	DESCRIPTION	P/N	QTY.
1	Arbor Block Assembly (includes items 1-7, 11-18, 25-34) [B2]	JSS-444	1
2	M6x6x18 Key [B1]	JSS-232	1
3	Arbor Spacer [B1]	JSS-233	1
4	Arbor Pulley [B1]	JSS-234	1
5	M6x23x3 Washer [B1]	JSS-235	1
6	M6x1.0x16 Flange Head Phillips Screw [B1]	JSS-236	1
7	Retraction Guide Pin [B1]	JSS-237	1
8	Belt (Replacement Kit) [A1]	JSS-238	1
9	M5x0.8x12 Socket Head Cap Combination Screw [A1]	JSS-239	2
10	Retraction Bracket [A1]	JSS-240	1
11	M6x1.0 Socket Head Shoulder Bolt (8mm x 33mm) [A1]	JSS-241	1
12	Retraction Spring [B1]	JSS-242	1
13	M8x16x2 Washer [B1]	JSS-243	1
14	Blade Diameter Limit Stop [B2]	JSS-446	1
15	M4x0.7x12 Button Head Socket Screw [B3]	JSS-447	1
16	M4x0.7 Lock Nut [A2]	JSS-244	2
17	M4x14x1 Washer [A2]	JSS-245	2
18	Cartridge Cable Assembly [C3]	JSS-246	1
19	Cartridge Bracket Spacer [A3]	JSS-247	2

ITEM	DESCRIPTION	P/N	QTY.
20	Arbor Pivot Shaft [B3]	JSS-248	1
21	Brake Cartridge for 10" Blade [C3]	TSBC-10R2 or TSBC-10R3	1
	Brake Cartridge for 8" Dado Set [C3]	TSDC-8R2 or TSDC-8R3	
22	Cartridge Key O-Ring [C3]	JSS-250	1
23	Cartridge Key (includes item 22) [C3]	JSS-251	1
24	Arbor Nut [C3]	JSS-252	1
25	Arbor Washer [C3]	JSS-448	1
27	10" Combination Saw Blade [C3]	JSS-254	1
28	M4x0.7x20 Flat Head Socket Screw [B2]	JSS-255	2
29	Cartridge Positioning Pin [B2]	JSS-256	1
30	M8x16x2 Washer [B2]	JSS-257	1
31	M8x1.25 Lock Nut [B2]	JSS-258	1
32	M4 External Tooth Washer [A2]	JSS-259	3
33	M4x0.7x6 Button Head Socket Screw [A2]	JSS-260	3
34	M6x1.0 Alignment Block Bolt [B2]	JSS-261	1
35	M6x1.0 Lock Nut [C1]	JSS-262	1
36	Alignment Block [B1]	JSS-263	1
37	Block Alignment Spring [B1]	JSS-264	1

Coordinates in square brackets [ ] correspond to the grid in the exploded view.

## BLADE GUARD AND MITER GAUGE ASSEMBLY PARTS LIST

ITEM	DESCRIPTION	P/N	QTY.
N/A	Miter Gauge Assembly (includes items 1-8)	JSS-265	1
1	Miter Gauge Head [A1]	JSS-266	1
2	Miter Gauge Bar [B1]	JSS-267	1
3	Miter Gauge Handle [A1]	JSS-268	1
4	M6x16x1.6 Washer [A1]	JSS-269	1
5	M4x0.7x6 Pan Head Phillips Screw [A1]	JSS-270	1
6	M4x10x1 Washer [B1]	JSS-271	1
7	Miter Gauge Angle Indicator [B1]	JSS-272	1
8	M4x0.7 Pan Head Phillips Shoulder Screw (69mm x 63mm) [B1]	JSS-273	1
N/A	Removable Dust Collection Guard	JSS-RDC	1
N/A	Complete Top Guard Assembly (includes items 10-25)	JSS-RDC-030	1
9	Spreader [B3]	JSS-RDC-001	1
10	Top Guard [B2]	JSS-RDC-003	1
11	Grooved Clevis Pin (6mm x 42.5mm) [B2]	JSS-RDC-004	1
12	6mm E-Style Retaining Ring [B2]	JSS-RDC-005	1
13	Internally Threaded Sleeve [A3]	JSS-RDC-006	2
14	Lateral Guide Wheel [B3]	JSS-RDC-007	1
15	Lateral Guide Axle [B3]	JSS-RDC-008	1
16	M6x1.0x40 Button Head Socket Bolt [A3]	JSS-RDC-009	2

ITEM	DESCRIPTION	P/N	QTY.
17	M6x16x1.5 Washer [B4]	JSS-RDC-010	4
18	Height Adjustment Wheel [A3]	JSS-RDC-011	1
19	Top Guard Spring [A3]	JSS-RDC-012	1
20	Front Left Side Guard [C1]	JSS-RDC-013	1
21	Front Right Side Guard [C2]	JSS-RDC-014	1
22	Middle Guard [C2]	JSS-RDC-015	1
23	M4x16x3 Polycarbonate Custom Washer [C1]	JSS-RDC-016	1
24	M4x1.6x10 Pan Head Phillips Screw [C1]	JSS-RDC-017	1
25	M3x1.06x08 Pan Head Phillips Screw [C2] [C3]	JSS-RDC-018	8
26	M6x1.0x30 Button Head Socket Bolt [B2]	JSS-RDC-019	1
27	Anti-Kickback Pawl Left [B3]	JSS-RDC-020	1
28	Pawl Bushing [B3]	JSS-RDC-021	1
29	Anti-Kickback Pawl Right [B4]	JSS-RDC-022	1
N/A	Anti-kickback Pawl Assembly	JSS-RDC-031	1
30	M6x1.0 Lock Nut [B4]	JSS-RDC-023	1
31	Pawl Spring [B4]	JSS-RDC-024	1
32	Spring Pin [B3]	JSS-RDC-029	1

Coordinates in square brackets [ ] correspond to the grid in the exploded view.

# MOBILE CART ASSEMBLY

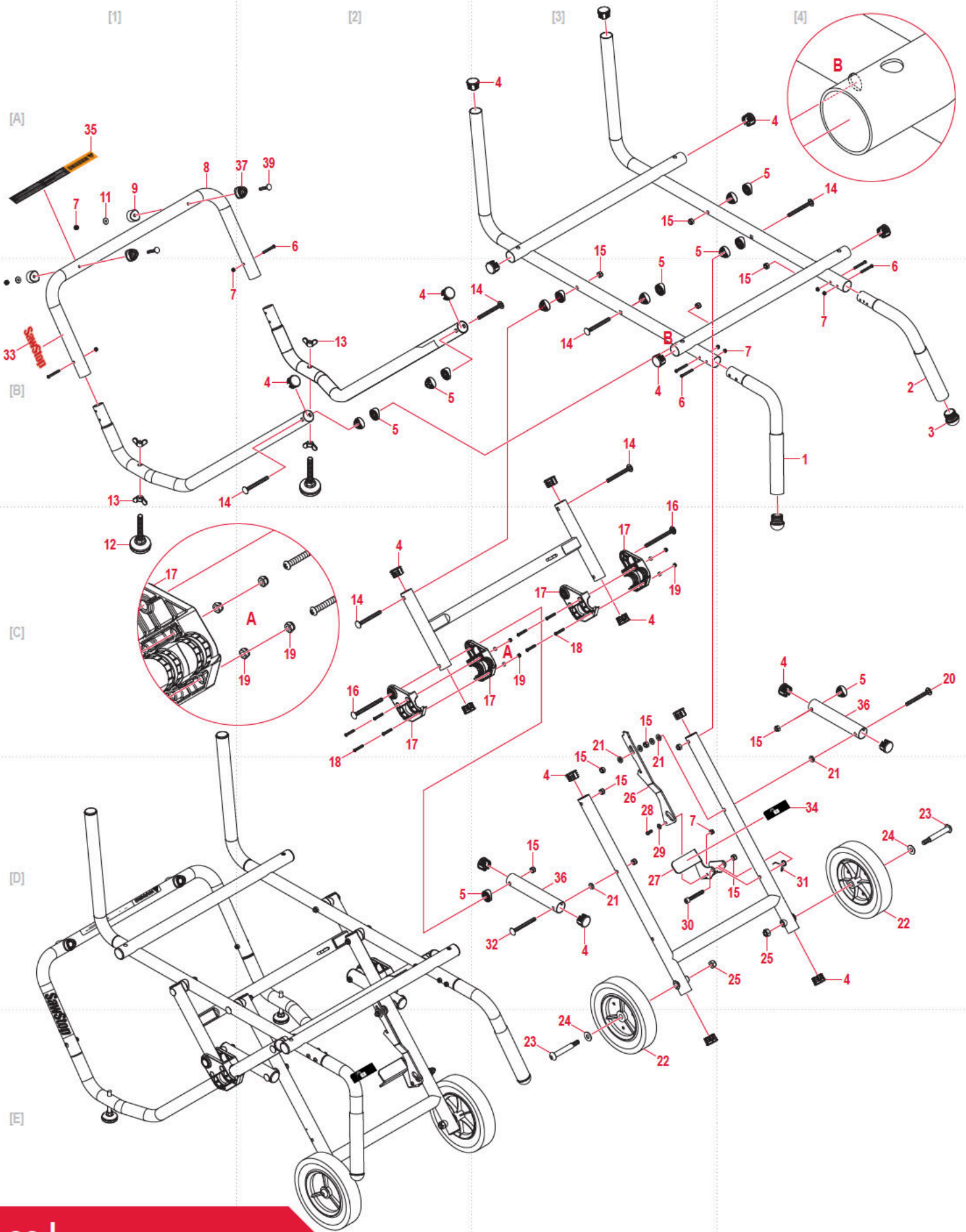

## MOBILE CART ASSEMBLY PARTS LIST

ITEM	DESCRIPTION	P/N	QTY.
N/A	Jobsite Saw Mobile Cart Assembly	MC-JSS	1
1	Left Handle Assembly (includes item 3) [B4]	MC-JSS-001	1
2	Right Handle Assembly (includes item 3) [B4]	MC-JSS-002	1
3	Handle End Cap [B4] [C4]	MC-JSS-003	2
4	Tube End Cap [A3, various]	MC-JSS-004	20
5	Pivot Bushing [A4, various]	MC-JSS-005	14
6	M6x1.0x40 Truss Head Phillips Screw [A2] [B1] [B3] [B4]	MC-JSS-006	6
7	M6x1.0 Lock Nut [A1] [B1] [B4] [D3]	MC-JSS-007	9
8	Storage Support Tube (includes items 33 & 35) [A1]	MC-JSS-008	1
9	Rubber Bumper [A1] [B1]	MC-JSS-009	2
11	M6x16x1 Washer [A1] [B1]	MC-JSS-011	2
12	Leveling Foot [B2] [C1]	MC-JSS-457	2
13	3/8-16 Wing Nut [B1] [B2]	MC-JSS-013	4
14	M8x1.25x82 Carriage Head Bolt [A4] [B2] [B3] [C2]	MC-JSS-014	6
15	M8x1.25 Thin Lock Nut [A3, various]	MC-JSS-015	12
16	M8x1.25x105 Carriage Head Bolt [C2] [C3]	MC-JSS-016	2
17	Sliding Coupler Assembly [C1] [C2] [C3]	MC-JSS-017	4
18	M5x0.8x30 Pan Head Phillips Screw [C2] [C3]	MC-JSS-018	8
19	M5x0.8 Lock Nut [C3]	MC-JSS-019	8
20	M8x1.25x100 Carriage Bolt [C4]	MC-JSS-020	1
21	M8x23x3 Washer [C3] [D3] [D4]	MC-JSS-021	6

ITEM	DESCRIPTION	P/N	QTY.
22	8" Wheel [D4] [E3]	MC-JSS-022	2
23	Wheel Axle Bolt [D4] [E3]	MC-JSS-023	2
24	M14x30x1.5 Washer [D4] [E3]	MC-JSS-024	2
25	M10x1.5 Lock Nut [D3] [D4]	MC-JSS-025	2
26	Cart Lock Release Latch [D3]	MC-JSS-026	1
27	Foot Pedal (includes item 34) [D3]	MC-JSS-027	1
28	M6x1.0x20 Pan Head Phillips Screw [D3]	MC-JSS-028	1
29	M6x16x1.6 Washer [D3]	MC-JSS-029	1
30	M8x1.25x55 Socket Head Cap Screw [D3]	MC-JSS-030	1
31	Foot Pedal Lock Spring [D4]	MC-JSS-031	1
32	M8x1.25x75 Carriage Bolt [D3]	MC-JSS-032	1
33	SawStop Logo Label [B1]	MC-JSS-033	1
34	Foot Pedal Label [D4]	MC-JSS-034	1
35	Warning Label [A1]	MC-JSS-035	1
36	Connection Tube [C4] [D3]	MC-JSS-036	2
N/A	Mobile Cart Component Part Box (includes items 1-2, 22, MC-JSS-038)	MC-JSS-037	1
N/A	Mobile Cart Hardware Bag (includes items 6-7, 23-25)	MC-JSS-038	1
37	Frame Support Pad [A1] [A2]	MC-JSS-039	2
39	M6x1.0x45 Carriage Head Bolt [A1] [A2]	MC-JSS-045	2

Coordinates in square brackets [ ] correspond to the grid in the exploded view.

## LITERATURE AND TOOLS

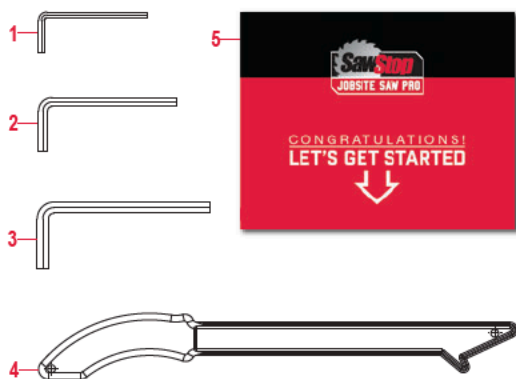

ITEM	DESCRIPTION	P/N	QTY.
N/A	Owner's Manual	JSS-453	1
1	3mm hex L-Wrench	JSS-303	1
2	4mm hex L-Wrench	JSS-304	1
3	5mm hex L-Wrench	JSS-305	1
4	Push Stick	JSS-454	1
5	Unpacking Procedure Poster	JSS-455	1

# TEMPLATES

## PUSH STICK

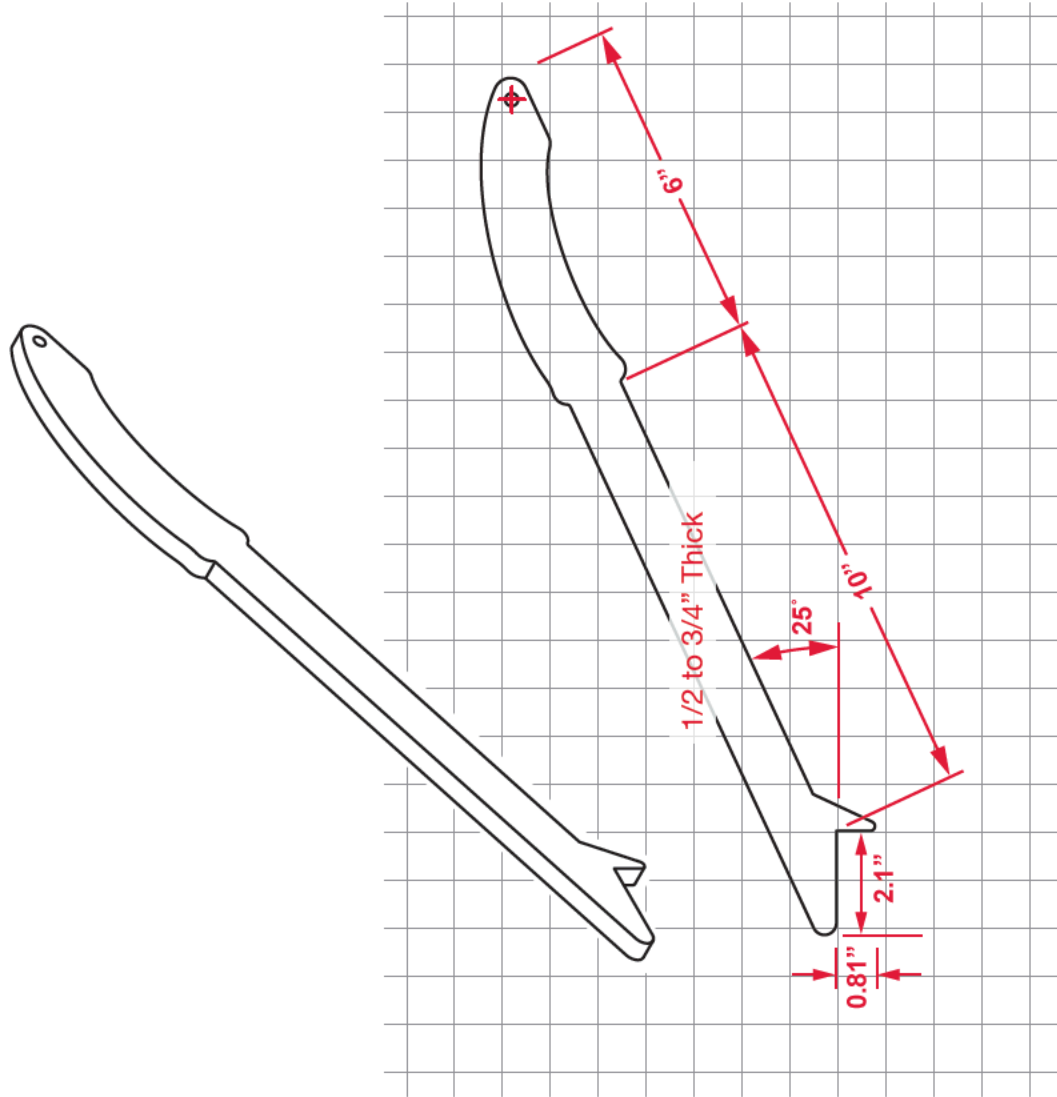

- 1/2" to 3/4" thick
- Sturdy, electrically non-conductive (for example, scrap wood)
- Use when rip cutting pieces narrower than 6"

Grid squares are 1 inch.

# FEATHERBOARD

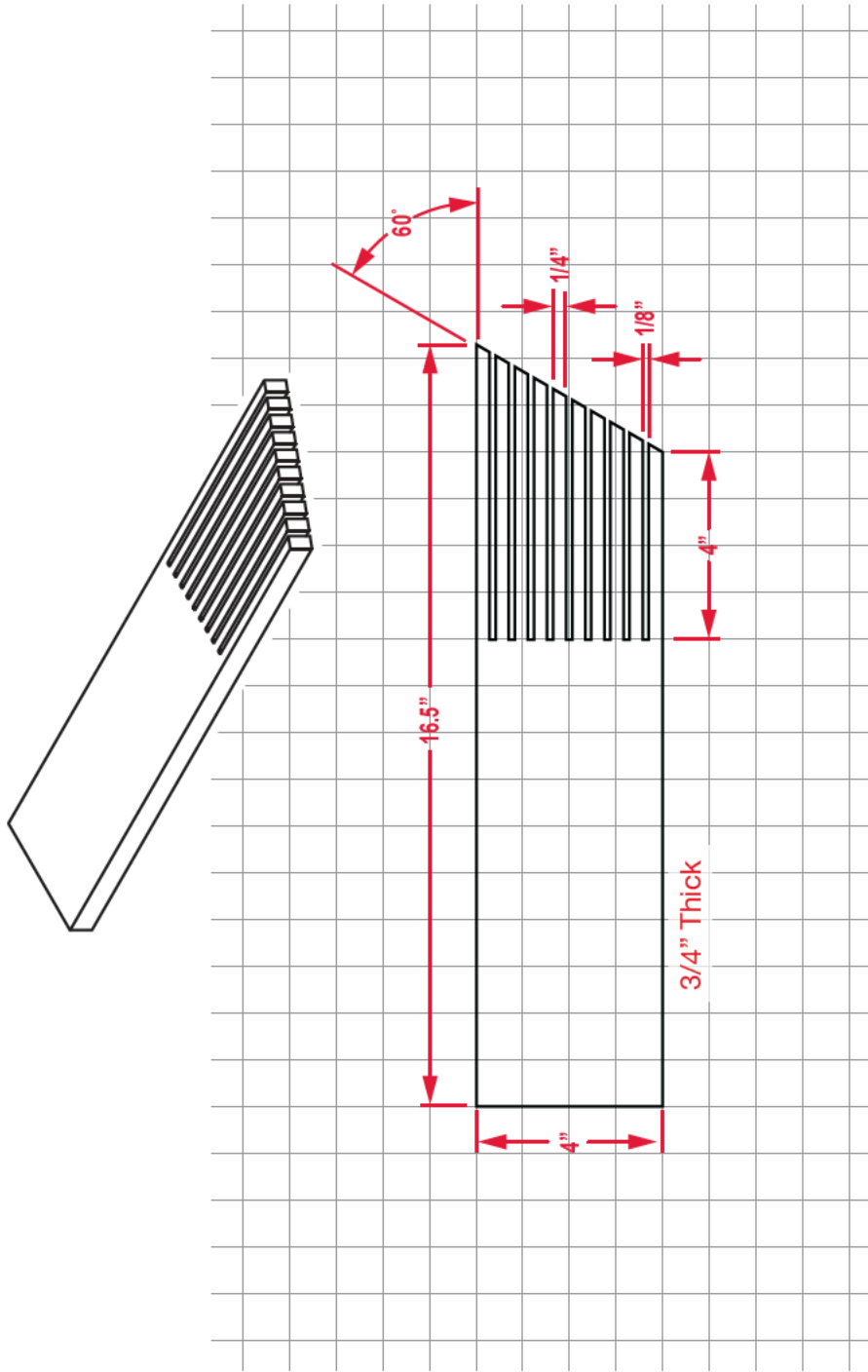

Grid squares are 1 inch.

- 3/4" thick, good quality wood, no knots
- Do not use when cutting with the miter gauge

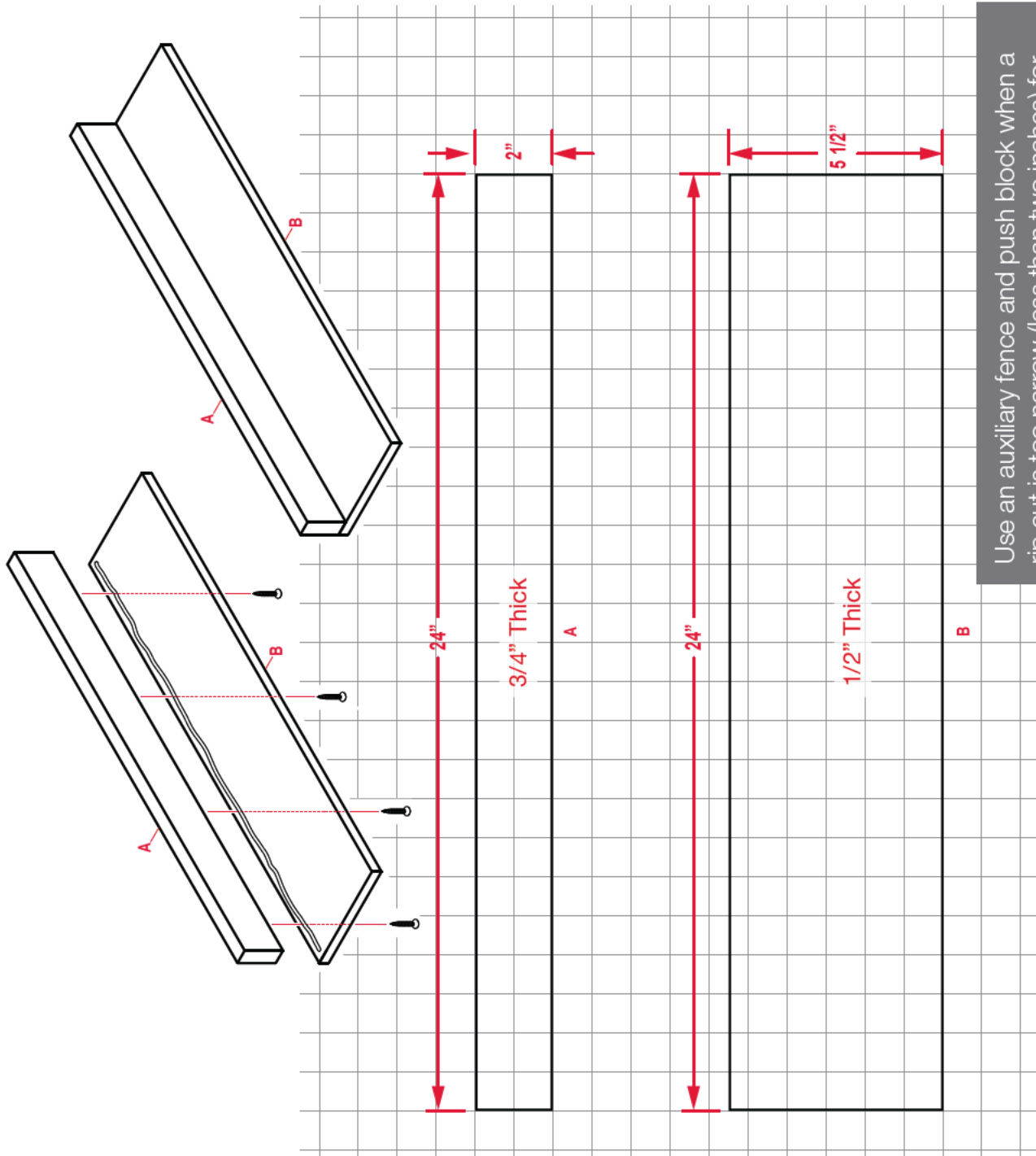

Use an auxiliary fence and push block when a rip cut is too narrow (less than two inches) for a push stick (see page 71). Attach A to B as shown using wood glue and counter-sunk wood screws.

Grid squares are 1 inch.

# PUSH BLOCK

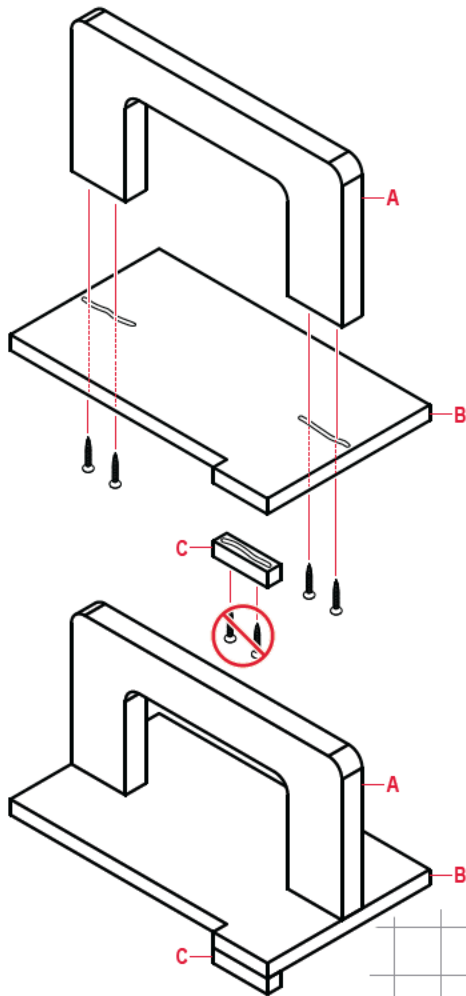

Use with auxiliary fence.

1. Attach A to center of B using wood glue and counter-sunk wood screws
2. Attach C to B as shown using wood glue only (DO NOT USE metal fasteners).

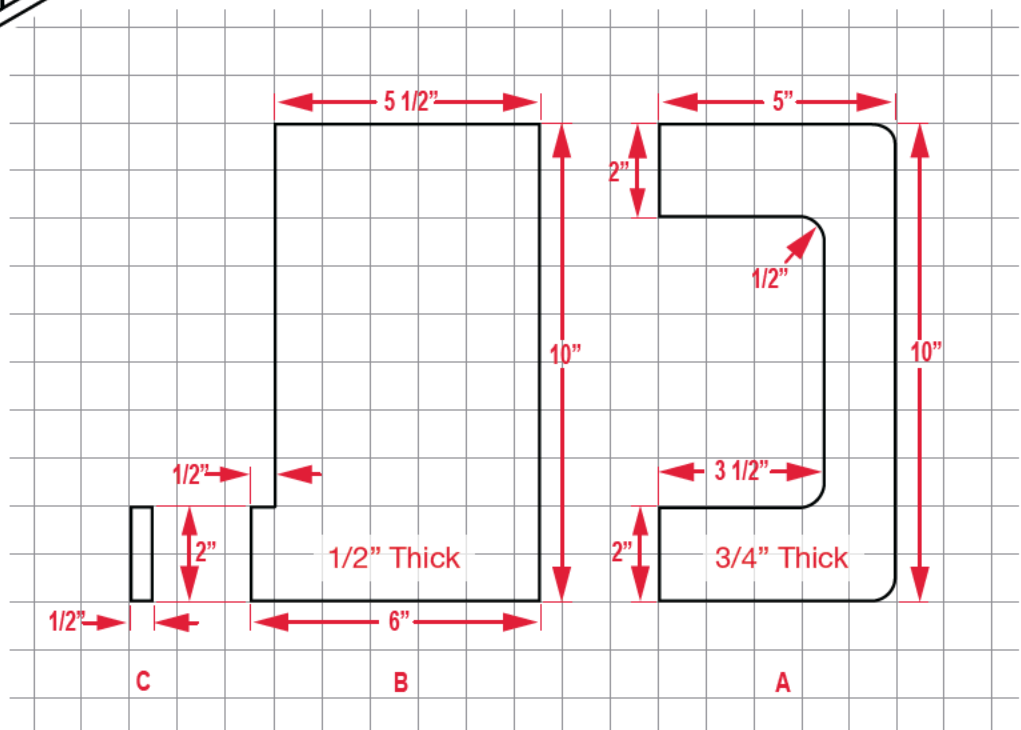

Grid squares are 1 inch.

This page is intentionally blank.

This page is intentionally blank.

