

JOHN DEERE
AG & TURF DIVISION

Compact Utility Tractors
1023E, 1026R

OMLVU24604 A4

OPERATOR'S MANUAL



JOHN DEERE

⚠ WARNING: Diesel engine exhaust and some of its constituents are known to the State of California to cause cancer, birth defects, and other reproductive harm.

California Proposition 65 Warning

North American Version
Printed in U.S.A.



Introduction

Thank You for Purchasing a John Deere Product

We appreciate having you as a customer and wish you many years of safe and satisfied use of your machine.

Using Your Operator's Manual

This manual is an important part of your machine and should remain with the machine when you sell it.

Reading your operator's manual will help you and others avoid personal injury or damage to the machine. Information given in this manual will provide the operator with the safest and most effective use of the machine. Knowing how to operate this machine safely and correctly will allow you to train others who may operate this machine.

If you have an attachment, use the safety and operating information in the attachment operator's manual along with the machine operator's manual to operate the attachment safely and correctly.

This manual and safety signs on your machine may also be available in other languages (see your authorized dealer to order).

Sections in your operator's manual are placed in a specific order to help you understand all the safety messages and learn the controls so you can operate this machine safely. You can also use this manual to answer any specific operating or servicing questions. A convenient index located at the end of this book will help you to find needed information quickly.

The machine shown in this manual may differ slightly from your machine, but will be similar enough to help you understand our instructions.

RIGHT-HAND and LEFT-HAND sides are determined by facing in the direction the machine will travel when going forward. When you see a broken line (-----), the item referred to is hidden from view.

Before delivering this machine, your dealer performed a predelivery inspection to ensure best performance.

Special Messages

Your manual contains special messages to bring attention to potential safety concerns, machine damage as well as helpful operating and servicing information. Please read all the information carefully to avoid injury and machine damage.



CAUTION: Avoid injury! This symbol and text highlight potential hazards or death to the operator or bystanders that may occur if the hazards or procedures are ignored.

IMPORTANT: Avoid damage! This text is used to tell the operator of actions or conditions that might result in damage to the machine.

NOTE: General information is given throughout the manual that may help the operator in the operation or service of the machine.

Attachments for Your Machine

There's a John Deere attachment or kit to make your new machine perform more tasks or be more versatile, whether your machine is a lawn tractor or compact utility tractor or a utility vehicle.

You can check out the entire line of attachments for your machine at JohnDeere.com or ask your John Deere dealer. From aerators to electric lift kits to tillers, there's a John Deere attachment or kit to fill every need.

Required Emission-Related Information Service Provider

A repair shop or person of the owner's choosing may maintain, replace, or repair emission control devices and systems with original or equivalent replacement parts. However, warranty, recall, and all other services paid for by John Deere must be performed at an authorized John Deere service center.

Product Identification

Record Identification Numbers

Compact Utility Tractor

1023E PIN (010001-)

1026R PIN (010001-)

If you need to contact an Authorized Service Center for information on servicing, always provide the product model and identification numbers.

You will need to locate the identification numbers for the product. Record the information in the spaces provided below.

DATE OF PURCHASE:

DEALER NAME:

DEALER PHONE:

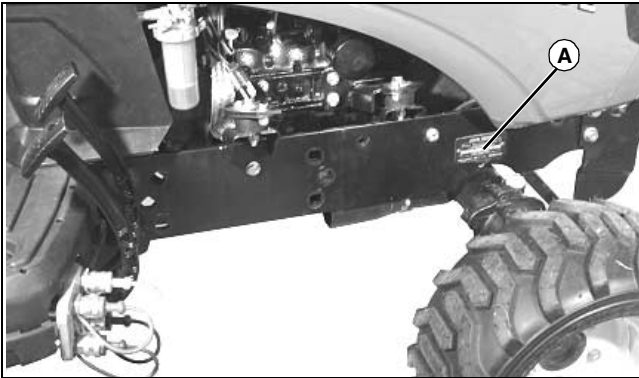

MX46292

PRODUCT IDENTIFICATION NUMBER (A):

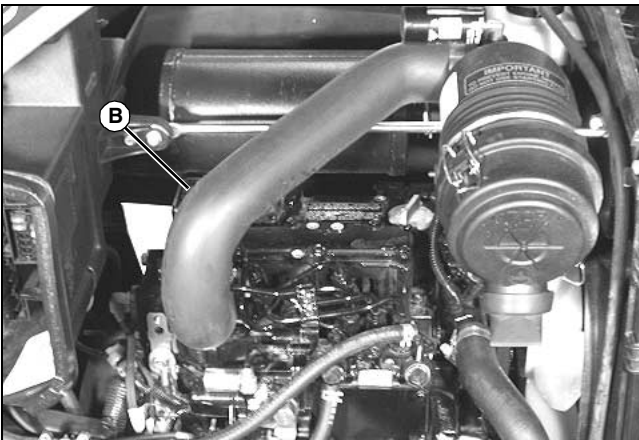

MX46293

ENGINE SERIAL NUMBER (B):

Table of Contents

Safety Labels	1
Safety	5
Operating Controls	10
Operating	11
Replacement Parts	32
Service Intervals	33
Service Lubrication	35
Service Engine	37
Service Transmission.....	47
Service Electrical.....	53
Service Steering & Brakes.....	57
Service Miscellaneous.....	59
Troubleshooting	63
Storage.....	68
Specifications	69
Warranty	73
Index.....	76

Original Instruction

All information, illustrations and specifications in this manual are based on the latest information at the time of publication. The right is reserved to make changes at any time without notice.

COPYRIGHT© 2024

Deere & Co.

John Deere Ag & Turf Division

All rights reserved

Previous Editions

COPYRIGHT©

2010, 2011

OMLVU24604 A4 -

Safety Labels

Safety Label Location

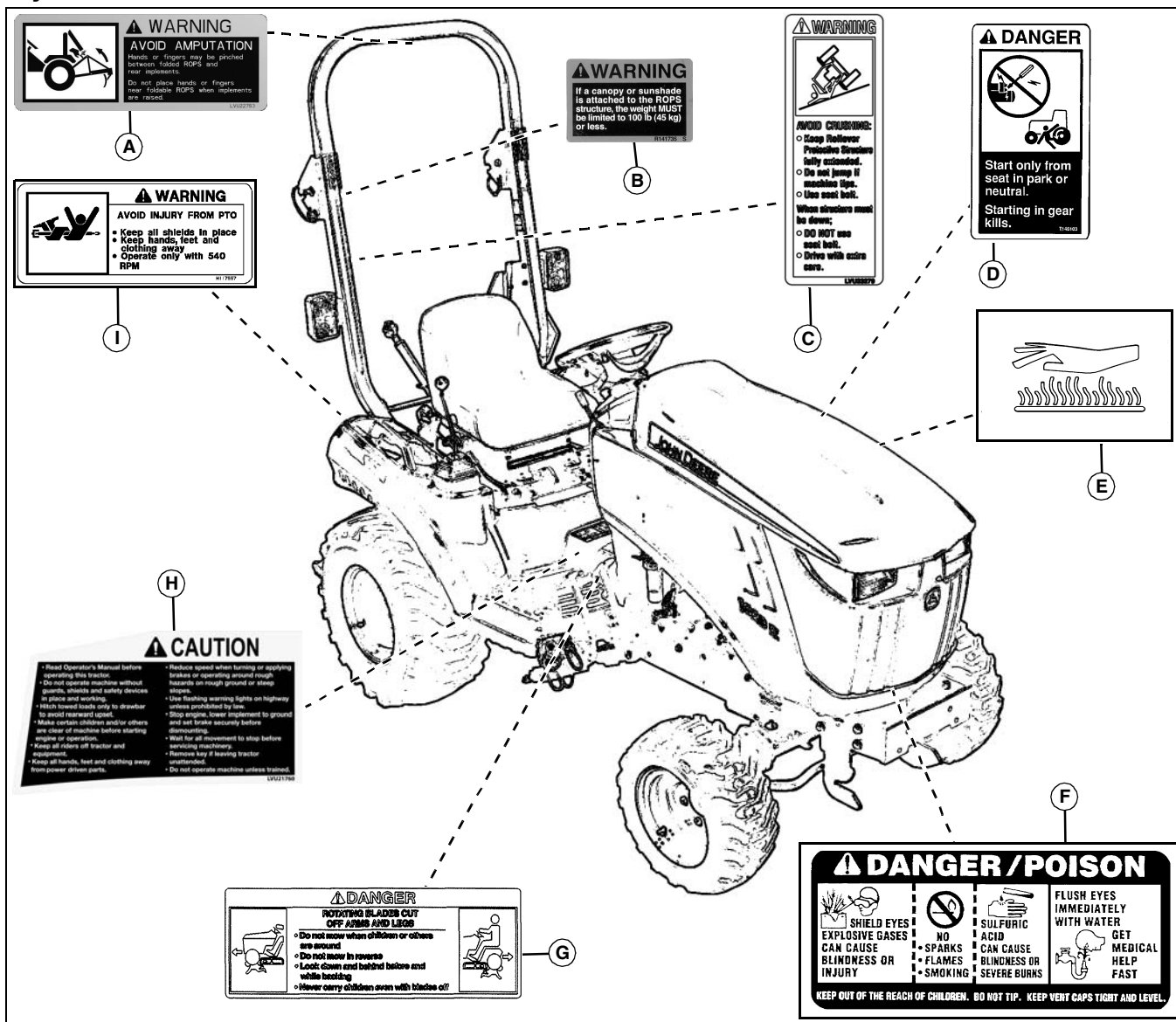

MX46294

- A - WARNING LVU22753
- B - WARNING R141735
- C - WARNING LVU23279
- D - DANGER T146103
- E - CAUTION HOT SURFACE (embossed on muffler)
- F - DANGER/POISON M88249
- G - DANGER LVU14509
- H - CAUTION LVU21760
- I - WARNING M117557



Understanding The Machine Safety Labels

The machine safety labels shown in this section are placed in important areas on your machine to draw attention to potential safety hazards.

On your machine safety labels, the words DANGER, WARNING, and CAUTION are used with this safety-alert symbol. DANGER identifies the most serious hazards.

The operator's manual also explains any potential safety hazards whenever necessary in special safety messages that are identified with the word, CAUTION, and the safety-alert symbol.

There can be additional safety information contained on parts and components sourced from suppliers that is not reproduced in this operator's manual.

Safety Labels

WARNING LVU22753

AVOID AMPUTATION



LVU22753

- Hands or fingers may be pinched between folded ROPS and rear implements. Do not place hands or fingers near foldable ROPS when implements are raised.

WARNING - LVU23279

AVOID CRUSHING



LVU23279

- Keep Rollover Protective Structure fully extended.
- Do not jump if machine tips.
- Use seat belt.

When structure must be down;

- DO NOT use seat belt.
- Drive with extra care.

DANGER T146103



T146103

Start only from seat in park or neutral.

Starting in gear kills.

WARNING M117557

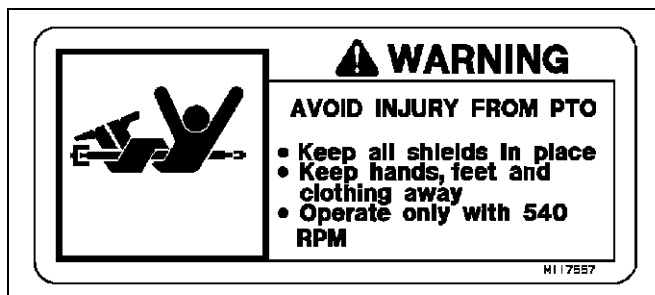

M117557

AVOID INJURY FROM PTO.

- Keep all shields in place.
- Keep hands, feet and clothing away.
- Operate only with 540 RPM.

WARNING ROPS R141735



R141735

Picture Note: Located on inside of right side of ROPS.

If a canopy or sunshade is attached to the ROPS structure, the weight MUST be limited to 100 lb (45 kg) or less.

Safety Labels

CAUTION - LVU24222

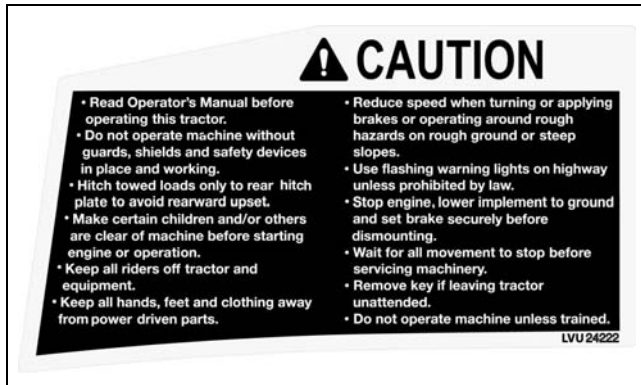

LVU24222

1. Read Operator's Manual before operating this tractor.
2. Do not operate the machine without guards, shields, and safety devices in place and working.
3. Hitch towed loads only to rear hitch plate to avoid rearward upset.
4. Make certain children and/or others are clear of machine before starting engine or operation.
5. Keep all riders off tractor and equipment.
6. Keep hands, feet and clothing away from power driven parts.
7. Reduce speed when turning or applying brakes or operating around rough hazards on rough ground or steep slopes.
8. Use flashing warning lights on highway unless prohibited by law.
9. Stop engine, lower implement to ground and set brake before dismounting.
10. Wait for all movement to stop before servicing machinery.
11. Remove key if leaving tractor unattended.
12. Do not operate machine unless trained.

DANGER - LVU14509

ROTATING BLADES CUT OFF ARMS AND LEGS

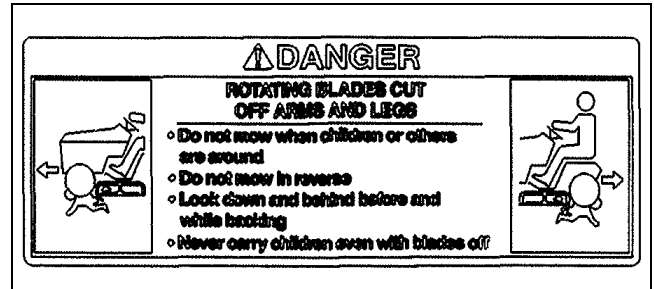

LVU14509

- Do not mow when children or others are around.
- Do not mow in reverse.
- Look down and behind before and while backing.
- Never carry children even with blades off.

DANGER / POISON

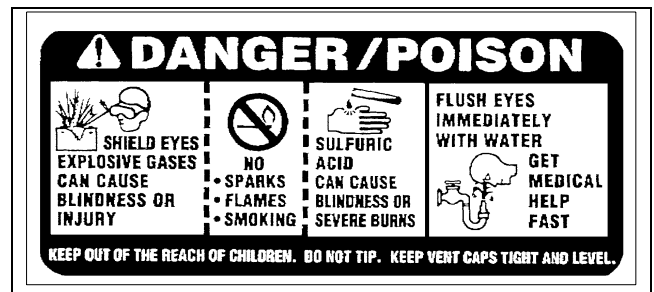

M88249

Picture Note: Located on battery.

SHIELD EYES: EXPLOSIVE GASES CAN CAUSE BLINDNESS OR INJURY.

NO SPARKS, FLAMES, SMOKING.

SULFURIC ACID CAN CAUSE BLINDNESS OR SEVERE BURNS.

FLUSH EYES IMMEDIATELY WITH WATER. GET MEDICAL HELP FAST.

KEEP OUT OF THE REACH OF CHILDREN. DO NOT TIP. KEEP VENT CAPS TIGHT AND LEVEL.

Safety Labels

CAUTION HOT SURFACE

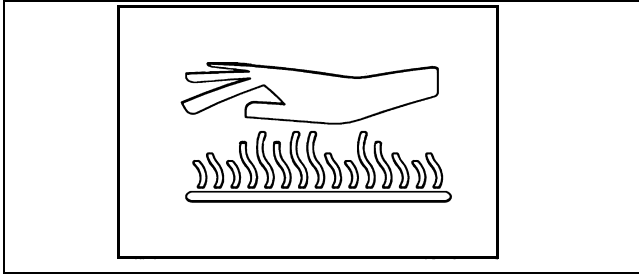

Picture Note: Located on muffler.

NOTE: No-text warning molded into muffler.

Do not touch engine muffler, it may be hot.

CAUTION: Avoid injury! Statutes providing severe penalties for tampering with emissions controls may apply at the user's location.

The emissions warranty described in the warranty section applies only to those engines marketed by John Deere that have been certified by the United States Environmental Protection Agency (EPA) and/or California Air Resources Board (CARB); and used in the United States in non-road mobile (self-propelled or portable/transportable¹) equipment. The presence of an emissions label like the one shown signifies that the engine has been certified with the EPA and/or CARB. The EPA and CARB warranties only apply to new engines having the certification label affixed to the engine and sold as stated above in the geographic areas governed by the regulating agencies.

NOTE: The hp/kW rating on the engine emissions certification label specifies the gross engine hp/kW, which is flywheel power without fan. In most applications this will not be the same rating as the advertised vehicle hp/kW rating.

CAUTION iMatch™ Quick-Hitch LVU13502



LVU13502

Picture Note: Optional iMatch Quick-Hitch.

BEFORE USING, SECURE TRACTOR IMPLEMENT WITH BOTH LOCKING LUGS OVER LOWER IMPLEMENT PINS

Emission Control System Certification Label

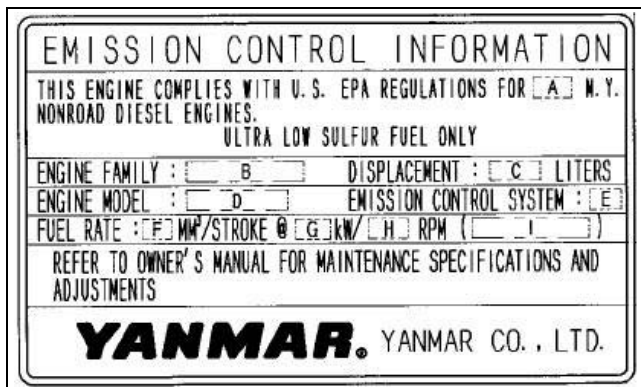

1. Equipment moved at least once every 12 months.

Safety

Operator Training Required

- Read the operator's manual and other training material. If the operator or mechanic cannot read English, it is the owner's responsibility to explain this material to them. This publication is available in other languages.
- Become familiar with the safe operation of the equipment, operator controls, and safety signs.
- All operators and mechanics should be trained. The owner of the machine is responsible for training the users.
- Never let children or untrained people operate or service the equipment. Local regulations may restrict the age of the operator.
- The owner/user can prevent and is responsible for accidents or injuries occurring to themselves, other people, or property.
- Operate the machine in an open, unobstructed area under the direction of an experienced operator.

Operating Safely

- Only allow responsible adults, who are familiar with the instructions, to operate the machine. Local regulations may restrict the age of the operator.
- A storage location is provided on the machine for the operator's manual. Keep the manual stored securely in this location when not in use and show other operators of this machine where the operator manual is located.
- Inspect machine before you operate. Be sure hardware is tight. Repair or replace damaged, badly worn, or missing parts. Be sure guards and shields are in good condition and fastened in place. Make any necessary adjustments before you operate.
- Be sure all drives are in neutral and parking brake is locked before starting engine. Only start engine from the operator's position.
- Do not change the engine governor settings or overspeed the engine. Operating the engine at excessive speed can increase the hazard of personal injury.
- Check brakes before you operate. Adjust or service brakes as necessary.
- Slow down and use extra care on hillsides. Be sure to travel in the recommended direction on hillsides. For this machine, drive up and down hillsides, not across. Turf conditions can affect the machine's stability. Use caution while operating near drop-offs.
- Stop machine if anyone enters the area. Never carry passengers and keep pets and bystanders away.
- Look behind and down before backing up to be sure of a

clear path.

- Inspect the area where the equipment is to be used and remove all objects such as rocks, toys and wire which can be thrown by the machine.
- If you hit an object or if abnormal vibration occurs, stop the machine and inspect it. Make repairs before you operate. Keep machine and attachments properly maintained and in good working order.
- Do not leave machine unattended when it is running.
- Only operate during daylight or with good artificial light.
- Evaluate the terrain to determine what accessories and attachments are needed to properly and safely perform the job.
- Use only accessories and attachments approved by the manufacturer of the machine. Keep safety labels visible when installing accessories and attachments.
- Do not operate machine if you are under the influence of drugs or alcohol.
- Check before each use that operator presence controls are functioning correctly. Test safety systems. Do not operate unless they are functioning correctly.
- Slow down and be careful of traffic when operating near or crossing roadways. Use care when approaching blind corners, shrubs, trees, or other objects that may obscure vision.
- Do not wear radio or music headphones. Safe service and operation require your full attention.
- Use care when loading or unloading the machine into or off of a trailer or truck.
- Disengage drive to attachments when transporting or not in use.
- Reduce the throttle setting during engine run-out and, if the engine is provided with a fuel shut-off valve, turn the fuel off at the conclusion of mowing.
- When machine is left unattended, stored, or parked, lower the mower deck unless a positive mechanical lock is used.

Using a Spark Arrestor

The engine in this machine is not equipped with a spark arrestor muffler. The California Public Resources Code, section 4442.5 provides as follows:

No person shall sell, offer for sale, lease, or rent to any person any internal combustion engine subject to Section 4442 or 4443, and not subject to Section 13005 of the Health and Safety Code, unless the person provides a written notice to the purchaser or bailee, at the time of sale or at the time of entering into the lease or rental contract,

Safety

stating that it is a violation of Section 4442 or 4443 to use or operate the engine on any forest-covered, brush-covered, or grass-covered land unless the engine is equipped with a spark arrestor, as defined in Section 4442, maintained in effective working order or the engine is constructed, equipped, and maintained for the prevention of fire pursuant to Section 4443. Cal. Pub. Res. Code 4442.5.

Other states or jurisdictions may have similar laws. A spark arrestor for your machine may be available from your authorized dealer. An installed spark arrestor must be maintained in good working order by the operator.

Parking Safely

1. Stop machine on a level surface, not on a slope.
2. Disengage PTO and stop attachments.
3. Lower attachments to the ground.
4. Lock park brake.
5. Stop engine.
6. Remove key.
7. Wait for engine and all moving parts to stop before you leave the operator's station.
8. Close fuel shut off valve before servicing the fuel system, if your machine is equipped.
9. Disconnect the battery ground cable before making repairs to electrical system or doing any welding.

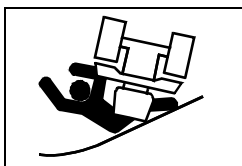

Avoid Tipping

• Slopes are a major factor related to loss-of-control and tip-over accidents, which can result in severe injury or death. Operation on all slopes

requires extra caution.

- Be aware that mechanical front wheel drive (MFWD) can improve access to dangerously sloped terrain, thereby increasing the possibility of a tipover.
- Drive up and down a hill - not across.
- Watch for holes, ruts, bumps, rocks, or other hidden objects. Uneven terrain could overturn the machine. Tall grass can hide obstacles.
- Do not operate machine on wet grass. Tires may lose traction. Tires may lose traction on slopes even though the brakes are functioning properly.
- Choose a low ground speed so you will not have to stop or shift while on a slope.

- Always keep the machine in gear when going down slopes. Do not shift to neutral and coast downhill.
- Avoid starting, stopping or turning on a slope. If the tires lose traction, disengage the blades and proceed slowly, straight down the slope.
- Keep all movement on slopes slow and gradual. Do not make sudden changes in speed or direction, which could cause the machine to roll over.
- Do not operate machine near drop-offs, ditches, embankments, or bodies of water. The machine could suddenly roll over if a wheel goes over the edge or the edge caves in. Leave a safety area between the machine and any hazard.
- Danger of tipping is increased greatly with tires in narrow tread setting and driving at high speed.
- Follow the manufacturer's recommendations for wheel weights or counterweights for added stability when operating on slopes or using front or rear mounted attachments. Remove weights when not required.



Prevent Machine Runaway

• Do not start engine by shorting across starter terminals. Machine will start in gear if normal circuitry is

bypassed.

• Never start engine while standing on ground. Start engine only from operator's seat, with transmission in neutral or park.



Use Seat Belt Properly

• Use a seat belt when you operate with a Roll-Over Protective Structure (ROPS) to minimize chance of injury from an accident, such as an

overturn.

- Never modify, disassemble or attempt to repair the seat belt.
- Replace entire seat belt if mounting hardware, buckle, belt, or retractor show signs of damage.
- Inspect seat belt and mounting hardware at least once a year. Look for signs of loose hardware or belt damage, such as cuts, fraying, extreme or unusual wear, discoloration, or abrasion. Replace only with John Deere-approved replacement parts.
- Layers of heavy clothing can interfere with proper positioning of the seat belt and can reduce the effectiveness of the seat belt.

Safety

Keep ROPS Installed Properly

- Never operate the machine without the ROPS installed.
- Make certain all parts of the ROPS are installed correctly if the ROPS structure is loosened or removed for any reason. All ROPS hardware should be tightened to the proper torque per manufacturer's recommendations.
- Any alteration of the ROPS must be approved by the manufacturer. The protection provided by the ROPS will be impaired if the ROPS is subjected to structural damage, is involved in an overturn incident, or is in any way altered by welding, bending, drilling, or cutting.
- The seat is part of the ROPS safety zone. Replace only with John Deere-approved seat.
- Never attempt to repair a damaged or altered ROPS. It must be replaced to maintain the manufacturer's certification of the structure.

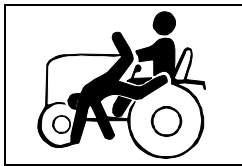

Keep Riders Off

- Only allow the operator on the machine. Keep riders off.
- Riders on the machine or attachment may be struck by foreign objects or thrown off the machine causing serious injury.
- Riders obstruct the operator's view resulting in the machine being operated in an unsafe manner.

Towing Loads Safely

- Stopping distance increases with speed and weight of towed load. Travel slowly and allow extra time and distance to stop.
- Total towed weight must not exceed combined weight of pulling machine, ballast and operator. Use counterweights or wheel weights as described in the attachment or pulling machine operator's manual.
- Excessive towed load can cause loss of traction and loss of control on slopes. Reduce towed weight when operating on slopes.
- Never allow children or others in or on towed equipment.
- Use only approved hitches. Tow only with a machine that has a hitch designed for towing. Do not attach towed equipment except at the approved hitch point.
- Follow the manufacturer's recommendations for weight limits for towed equipment and towing on slopes.
- If you cannot back up a slope with a towed load, the slope is too steep to operate on with the towed load. Reduce the towed load or do not operate.

- Do not turn sharply. Use additional caution when turning or operating under adverse surface conditions. Use care when reversing.
- Do not shift to neutral and coast downhill.

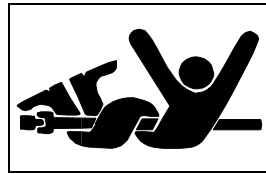

Stay Clear of Rotating Drivelines

Entanglement in rotating driveline can cause serious injury or death.

- Wear close fitting clothing.
- Stop the engine and be sure PTO driveline is stopped before getting near it.

Checking Wheel Hardware

- A serious accident could occur causing serious injury if wheel hardware is not tight.
- Check wheel hardware tightness often during the first 100 hours of operation.
- Wheel hardware must be tightened to specified torque using the proper procedure anytime it is loosened.

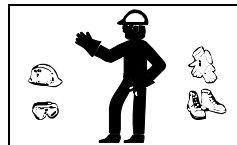

Wear Appropriate Clothing

- Always wear safety goggles, or safety glasses with side shields, and a hard hat when operating the machine.
- Wear close fitting clothing and safety equipment appropriate for the job.
- While operating this machine, always wear substantial footwear and long trousers. Do not operate the equipment when barefoot or wearing open sandals.
- Wear a suitable protective device such as earplugs. Loud noise can cause impairment or loss of hearing.

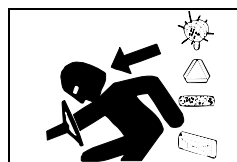

Driving Safely on Public Roads

Avoid personal injury or death resulting from a collision with another vehicle on public roads:

- Use safety lights and devices. Slow moving machines when driven on public roads are hard to see, especially at night.

Safety

- Whenever driving on public roads, use flashing warning lights and turn signals according to local regulations. Extra flashing warning lights may need to be installed.



Practice Safe Maintenance

- Only qualified, trained adults should service this machine. Understand service procedure before doing work.
- Never operate machine in a closed area where dangerous carbon monoxide fumes can collect.
- Keep all nuts and bolts tight, especially blade attachment bolts, to be sure the equipment is in safe working condition.
- Never tamper with safety devices. Check their proper operation regularly.
- Keep machine free of grass, leaves or other debris build-up. Clean up oil or fuel spillage and remove any fuel-soaked debris. Allow the machine to cool before storing.
- Never make any adjustments or repairs with the engine running. Wait for all movement to stop on machine before adjusting, cleaning or repairing.
- Check brake operation frequently. Adjust and service as required.
- Maintain or replace safety and instruction labels, as necessary.
- Keep hands, feet, clothing, jewelry, and long hair away from any moving parts, to prevent them from getting caught.
- Lower any attachments to the ground before cleaning or servicing machine. Disengage all power and stop the engine. Lock park brake and remove the key. Let machine cool.
- Securely support any machine elements that must be raised for service work. Use jack stands or lock service latches to support components when needed.
- Disconnect battery or remove spark plug wire (for gasoline engines) before making any repairs. Disconnect negative terminal first and positive last. Install positive terminal first and negative last.
- Before servicing machine or attachment, carefully release pressure from any components with stored energy, such as hydraulic components or springs.
- Release hydraulic pressure by lowering attachment or cutting units to the ground or to a mechanical stop and move hydraulic control levers back and forth.
- Keep all parts in good condition and properly installed. Fix damage immediately. Replace worn or broken parts.
- Charge batteries in an open, well-ventilated area, away

from sparks. Unplug battery charger before connecting or disconnecting from the battery. Wear protective clothing and use insulated tools.



Avoid High Pressure Fluids

- Hydraulic hoses and lines can fail due to physical damage, kinks, age, and exposure. Check hoses and lines regularly. Replace damaged hoses and lines.
- Hydraulic fluid connections can loosen due to physical damage and vibration. Check connections regularly. Tighten loose connections.
- Escaping fluid under pressure can penetrate the skin causing serious injury. Avoid the hazard by relieving pressure before disconnecting hydraulic or other lines. Tighten all connections before applying pressure.
- Search for leaks with a piece of cardboard. Protect hands and body from high pressure fluids.
- If an accident occurs, see a doctor immediately. Any fluid injected into the skin must be surgically removed within a few hours or gangrene may result. Doctors unfamiliar with this type of injury should reference a knowledgeable medical source. Such information is available from Deere & Company Medical Department in Moline, Illinois, U.S.A. Information may be obtained in the United States and Canada only by calling 1-800-822-8262.

Prevent Fires

- Machine fires and structure fires can occur if a machine is stored before allowing it to cool, if debris is not removed from critical areas of the machine, or if machine is stored near combustible materials.
- Remove grass and debris from engine compartment and muffler area, before and after operating machine.
- Always shut off fuel when storing or transporting machine, if the machine has a fuel shutoff.
- Do not store machine near an open flame or source of ignition, such as a water heater or furnace.
- Check fuel lines, tank, cap, and fittings frequently for cracks or leaks. Replace if necessary.



Tire Safety

Explosive separation of a tire and rim parts can cause serious injury or death:

Safety

- Do not attempt to mount a tire without the proper equipment and experience to perform the job.
- Always maintain the correct tire pressure. Do not inflate the tires above the recommended pressure. Never weld or heat a wheel and tire assembly. The heat can cause an increase in air pressure resulting in a tire explosion. Welding can structurally weaken or deform the wheel.
- When inflating tires, use a clip-on chuck and extension hose long enough to allow you to stand to one side and NOT in front of or over the tire assembly.
- Check tires for low pressure, cuts, bubbles, damaged rims or missing lug bolts and nuts.

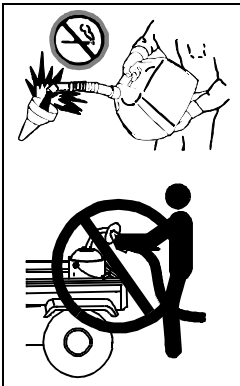

Handling Fuel Safely

To avoid personal injury or property damage, use extreme care in handling fuel. Fuel is extremely flammable and fuel vapors are explosive:

- Extinguish all cigarettes, cigars, pipes, and other sources of ignition.
- Use only an approved fuel container. Use only non-metal, portable fuel containers approved by the Underwriter's Laboratory (U.L.) or the American Society for Testing & Materials (ASTM). If using a funnel, make sure it is plastic and has no screen or filter.
- Never remove the fuel tank cap or add fuel with the engine running. Allow engine to cool before refueling.
- Never add fuel to or drain fuel from the machine indoors. Move machine outdoors and provide adequate ventilation.
- Clean up spilled fuel immediately. If fuel is spilled on clothing, change clothing immediately. If fuel is spilled near machine, do not attempt to start the engine but move the machine away from the area of spillage. Avoid creating any source of ignition until fuel vapors have dissipated.
- Never store the machine or fuel container where there is an open flame, spark, or pilot light such as on a water heater or other appliance.
- Prevent fire and explosion caused by static electric discharge. Static electric discharge can ignite fuel vapors in an ungrounded fuel container.
- Never fill containers inside a vehicle or on a truck or trailer bed with a plastic liner. Always place containers on the ground away from your vehicle before fueling.
- Remove fuel-powered equipment from the truck or trailer and refuel it on the ground. If this is not possible, then refuel such equipment with a portable container, rather

than from a fuel dispenser nozzle.

- Keep the nozzle in contact with the rim of the fuel tank or container opening at all times until the fueling is complete. Do not use a nozzle lock-open device.
- Never overfill fuel tank. Replace fuel tank cap and tighten securely.
- Replace all fuel container caps securely after use.
- For gasoline engines, do not use gas with methanol. Methanol is harmful to your health and to the environment.

Handling Waste Product and Chemicals

Waste products, such as, used oil, fuel, coolant, brake fluid, and batteries, can harm the environment and people:

- Do not use beverage containers for waste fluids - someone may drink from them.
- See your local Recycling Center or authorized dealer to learn how to recycle or get rid of waste products.
- A Material Safety Data Sheet (MSDS) provides specific details on chemical products: physical and health hazards, safety procedures, and emergency response techniques. The seller of the chemical products used with your machine is responsible for providing the MSDS for that product.

Operating Controls

Operator Station Controls

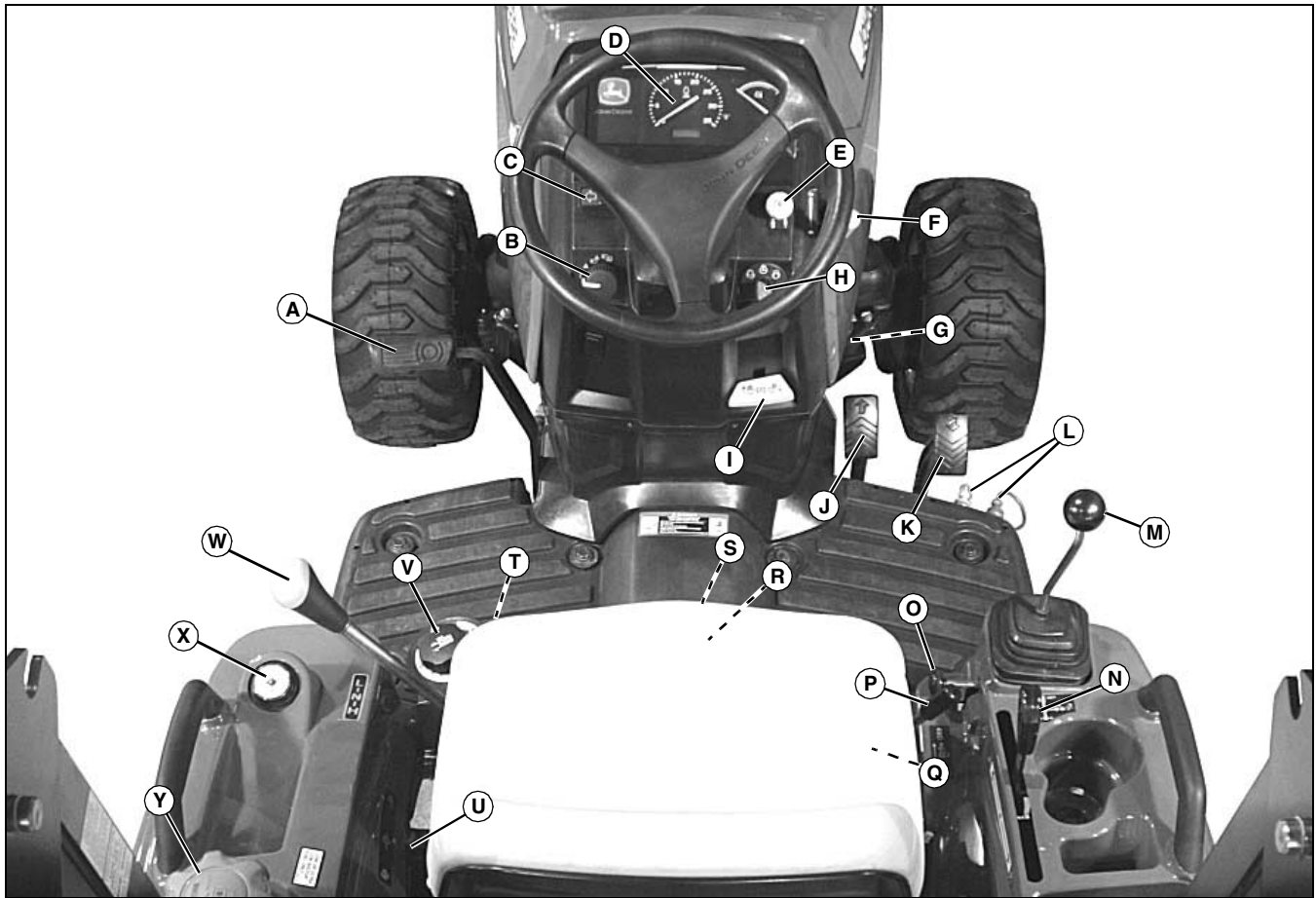

MX46284

Picture Note: Model 1023E Shown.

- A - Brake Pedal
- B - Light Control/Warning Flasher Light Switch
- C - Turn Signal Switch
- D - Instrument Cluster
- E - Power Take Off (PTO) Switch
- F - Engine Speed Hand Throttle
- G - Fuel Shut Off Valve
- H - Ignition Key Switch
- I - Park Brake Lock
- J - Forward Travel Pedal
- K - Reverse Travel Pedal
- L - Selective Control Valve (SCV) Couplers
- M - Selective Control Valve (SCV) Lever
- N - Rockshaft Control Lever
- O - Selective Control Valve (SCV) Lock Lever
- P - Mechanical Front Wheel Drive (MFWD) Control Lever
- Q - Rate of Drop / Lock Valve (1023E)
- R - Rate of Drop / Lock Valve (1026R)
- S - Operator Seat Adjustment Lever

- T - Differential Lock Pedal
- U - Power Take Off (PTO) Selector Lever
- V - Mower Deck Height Control
- W - Transmission Range Shift Lever
- X - Fuel Gauge
- Y - Fuel Filler Cap

Operating

Daily Operating Checklist

- Test safety systems. Perform safety interlock system checkout procedure.
- Check engine oil level.
- Check / drain water separator.
- Check transmission fluid level.
- Check coolant level.
- Clean air intake screen and radiator screen.
- Check air filter elements and dust valve.
- Check wheel bolt torques.
- Check tire pressure.
- Check fuel level.
- Remove grass and debris from machine.
- Check area below machine for leaks.

Avoid Damage to Plastic and Painted Surfaces

- Do not wipe plastic parts unless rinsed first. Using a dry cloth may cause scratches.
- Insect repellent spray may damage plastic and painted surfaces. Do not spray insect repellent near machine.
- Be careful not to spill fuel on machine. Fuel may damage surface. Wipe up spilled fuel immediately.
- Prolonged exposure to sunlight will damage hood surfaces.

Adjusting Seat

1. Sit on seat.

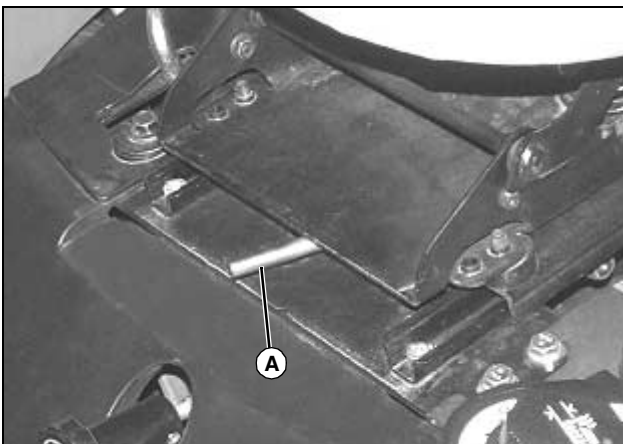

MX46196

2. Pull seat lever (A) sideways to unlock seat position.

3. Slide seat forward or rearward to desired position where all controls can be easily reached.
4. Release lever to lock seat in position.

Using Seat Belt



CAUTION: Avoid injury! Always wear seat belt when operating machine with non-folding Roll-Over Protective Structure (ROPS) or folding ROPS in upright position. Do not jump from machine if machine tips.

If folding ROPS must be folded to operate in a low clearance area, do not use seat belt. Raise ROPS and use seat belt as soon as conditions permit.

Fasten Seat Belt

1. Extend self-retracting seat belt and insert into latch on opposite side of seat. Seat belt is self-retracting and will automatically adjust to fit operator.

Release Belt

1. Press red button on buckle to release seat belt ends.

Adjusting Tilt Steering Wheel (1026R)



CAUTION: Avoid injury! Do not attempt to adjust the steering wheel while the machine is moving. The operator can lose control of the machine.

- Stop the machine before adjusting the steering wheel.
- Lock the steering wheel in position before driving the machine.

1. Stop machine.

Operating

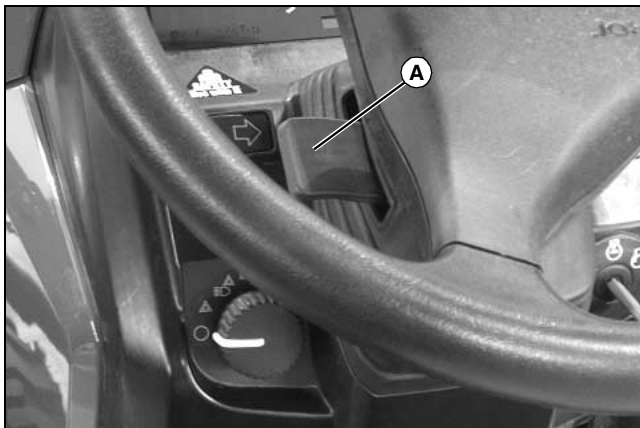

M46360

2. Pull tilt steering control lever (A) up to release steering wheel.
3. Adjust steering wheel to desired position.
4. Release tilt steering control lever to lock steering wheel in position.

Using Mower Height Control Knob



MX27908

Use mower height control knob (A) to adjust mower cutting height, and lock mower lift kit rear draft arms in raised or transport lock position. See your mower deck operator's manual for instructions.

IMPORTANT: Avoid damage! To avoid machine damage when operating without a mower, fully raise the mower lift kit rear draft arms, and turn mower height control knob clockwise to the transport position to lock the arms in raised position.

Using Light Switch

NOTE: Normal use of turn signals is possible when light switch is in either warning flasher position. Turn

signals will temporarily override warning flashers when activated. When turn signals are de-activated, warning flashers will resume operation.

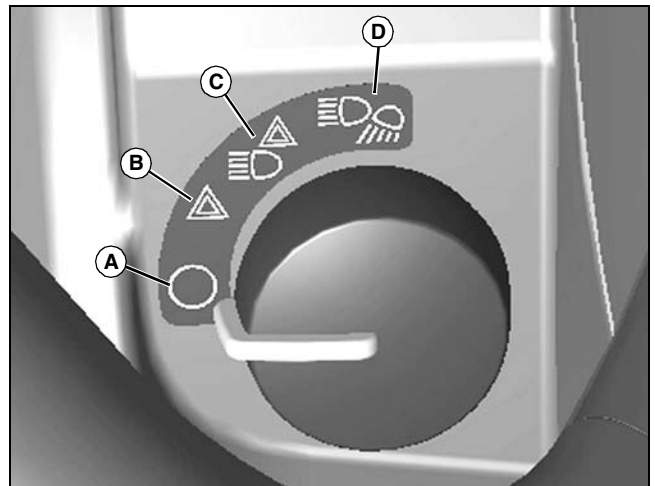

MX46198

- A - All Lights Off
- B - Warning Flasher Lights On
- C - Headlights, Taillights and Warning Flasher Lights On
- D - Headlights, Worklights and Taillights On

Using Key Switch

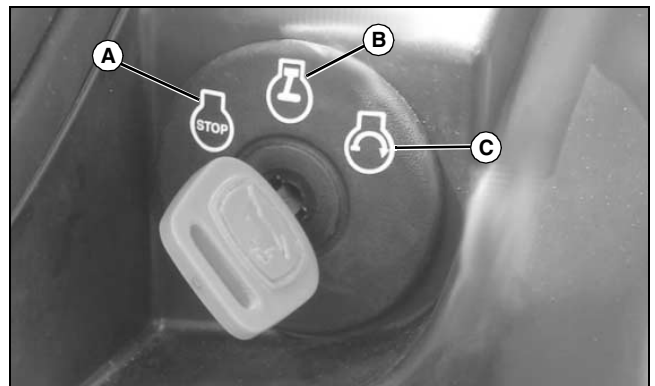

MX27906

- A - OFF Position - In this position the engine will not run.
- B - ON Position - Move key from OFF to this position and the engine oil pressure light and battery charging light will turn on and activate the glow plugs for 5 seconds. You will also hear the engine fuel shut-off solenoid engage with a click.
- C - START Position - Move key from ON to this position and the starter will engage the engine flywheel to start the engine. Release the key to the ON position.

Operating

Using Instrument Panel

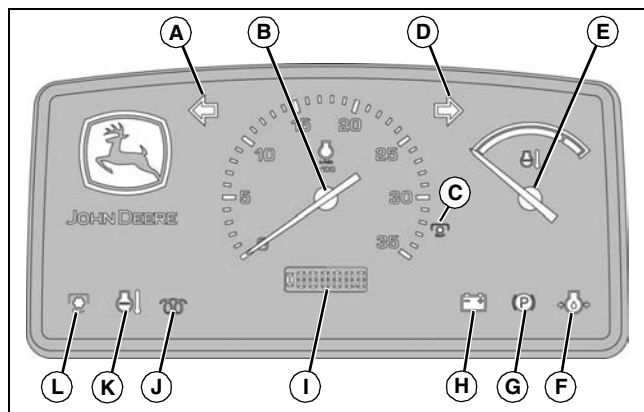

MX46199a

A - Left Turn Signal/Warning Flasher Indicator Light - This indicator light will turn on and flash when the turn signal switch is moved to the left turn position or when the light switch is turned to the warning flasher lights ON position or the headlights, taillights, and warning flasher lights ON position.

B - Tachometer - Shows engine speed. Engine speed is shown in 100's. Example: If indicator is pointing at 20 (20 x 100 = 2000 RPM).

Low idle speed 1575 ± 25 rpm

Rated speed 3200 rpm

Fast idle speed 3370 ± 50 rpm

C - Power Take Off Marker - When the tachometer needle points to the marker, it indicates proper engine speed for the 540 RPM Power Take Off (PTO).

D - Right Turn Signal/Warning Flasher Indicator Light - This indicator light will turn on and flash when the turn signal switch is moved to the right turn position or when the light switch is turned to the warning flasher lights ON position or the headlights, taillights, and warning flasher lights ON position.

E - Engine Coolant Temperature Gauge - This gauge indicates the temperature of the cooling system. If the gauge needle reaches the red range, the engine is overheating and PTO will automatically disengage.

If the engine is overheated, remove load on machine immediately. Reduce engine to idle speed and allow engine to cool. Stop engine. Check coolant level in overflow bottle and check for air flow blockage to the radiator. If coolant level is correct and needle stays in the red range after cleaning grille, stop engine.

F - Engine Oil Pressure Light - This light will turn on when the ignition key is in the ON position and the engine is not running. If this light turns on while the engine is running, engine oil pressure is too low. Stop engine.

G - Parking Brake Light - This light will turn on when the ignition key is in the ON position and the parking brake is locked.

H - Alternator/Battery Charging Light - This light will turn on when the ignition key is in the ON position and the engine is not running. If this light turns on while the engine is running, the alternator is not charging the battery. Move the throttle lever to the full throttle position. Stop the engine if light remains on.

I - Hour Meter - Shows total number of accumulated running hours. Use the hour meter as a guide when servicing various components of this machine.

J - Engine Glow Plug Indicator Light - This light will turn on when the ignition key is in the ON position and the engine glow plug is initially heated for five seconds. The glow plugs will also be energized whenever the starter is engaged.

K - Engine Coolant Temperature Light - This light will turn on when the engine coolant is above its high temperature limit. If this light turns on during operation, remove load on machine immediately. Reduce engine to idle speed and allow engine to cool. Stop engine. Check coolant level in overflow bottle and check for air flow blockage to the radiator. If coolant level is correct and light stays is on after cleaning grille, stop engine.

L - PTO Indicator Light - This light will turn on when the PTO is engaged.

Using Turn Signal Switch

NOTE: The turn signal switch will operate only when the ignition key switch is in the ON position.

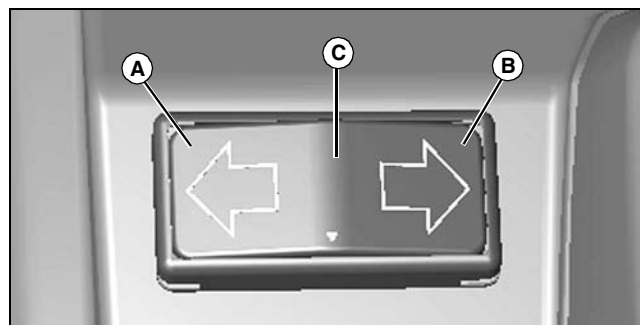

MX46198

1. Depress left side of switch (A) to operate the left turn signal light.
2. Depress right side of switch (B) to operate the right turn signal light.
3. Move switch to the centered position (C) to turn lights off.

Operating

Testing Safety Systems

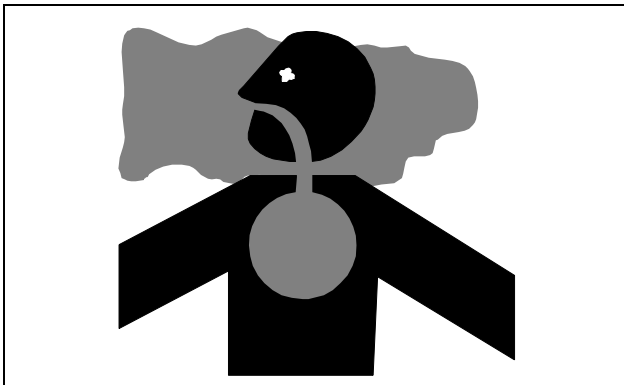

CAUTION: Avoid injury! Engine exhaust fumes contain carbon monoxide and can cause serious illness or death.

- Move the machine to an outside area before running the engine.
- Do not run an engine in an enclosed area without adequate ventilation.
- Connect a pipe extension to the engine exhaust pipe to direct the exhaust fumes out of the area.
- Allow fresh outside air into the work area to clear the exhaust fumes out.

The safety systems installed on your machine should be checked before each machine use. Be sure you have read the machine operator manual and are completely familiar with the operation of the machine before performing these safety system checks.

Use the following checkout procedures to check for normal operation of machine.

If there is a malfunction during one of these procedures, do not operate machine. **See your authorized dealer for service.**

Perform these tests in a clear open area. Keep bystanders away.

Testing the Neutral Start Switch

1. Sit on operator's seat.
2. Disengage PTO.
3. Move the transmission range shift lever to the H (high) or L (low) position.
4. Turn key switch to START position.

Result: Engine must not crank.

Testing the Power-Take-Off (PTO) Switch

1. Sit on operator's seat.
2. Move the transmission range shift lever to the N (neutral) position.
3. Engage PTO.
4. Turn key to the START position.

Result: Engine must not crank.

Testing the Seat Switch

1. Sit on operator's seat.
2. Do not depress the hydrostatic travel pedals.
3. Lock park brake.
4. Start engine.
5. Move the transmission range shift lever to the H (high) or L (low) position.
6. Raise up slightly from operator's seat. Do not dismount machine.

Result: Engine shut-off solenoid must de-energize in 1/2 second, causing the engine to stop.

Using Brake Pedal



MX46285

1. Depress pedal (A) to operate the brake.

Using Park Brake

NOTE: Label on dash illustrates park brake operation.

Operating

Locking Park Brake:

CAUTION: Avoid injury! Always lock park brake and move transmission range shift lever to a position other than N (neutral) before leaving machine unattended. Transmissions will not prevent machine motion without the park brake locked.

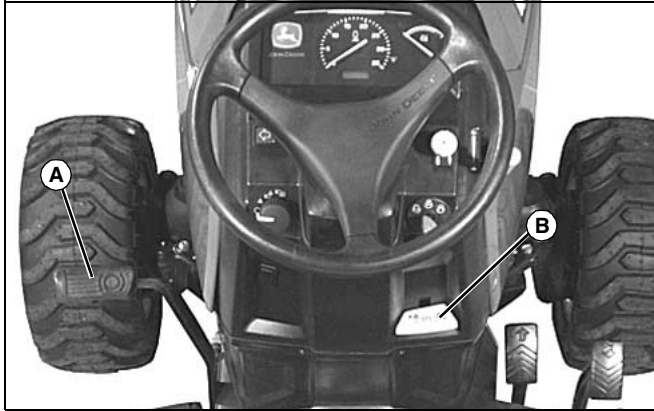

MX46285

1. Press down completely on brake pedal (A) with foot.
2. Lift park brake lock (B) completely up to the locked position.
3. Remove foot from brake pedal. Pedal should now stay down in the locked position.

Unlocking Park Brake:

1. Press down completely on brake pedal (A) with foot.
2. Push park brake lock (B) completely down to the unlocked position.
3. Remove foot from brake pedal. Pedal should now be released from the locked position.

Using Throttle



MX46285

Use the throttle to change engine speeds. Use the throttle in conjunction with the tachometer to set engine speeds.

- **Increase Engine Speed** - Push throttle lever (A) towards the front of the machine.
- **Decrease Engine Speed** - Pull throttle lever (A) towards rear of the machine.

Engine/Tachometer Speeds:

Low idle speed1575 rpm
Rated speed3200 rpm
PTO speed3200 rpm
Fast idle speed3370 ± 50 rpm

Using Fuel Gauge

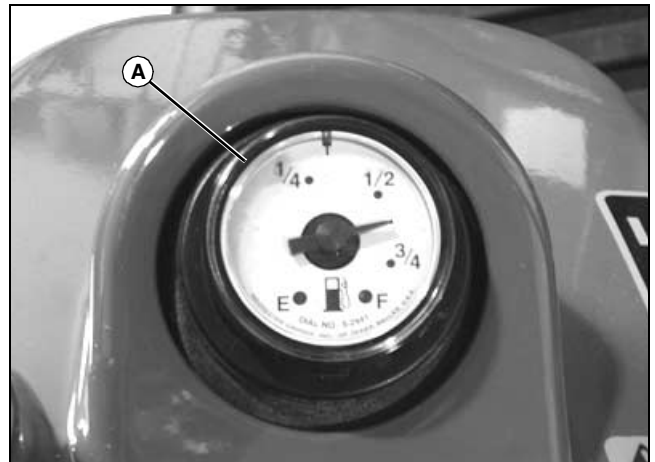

MX46286

1. The fuel gauge (A) shows approximately how much fuel is in the fuel tank.

Operating

Using Fuel Shut-Off Valve



CAUTION: Avoid injury! Close fuel shut-off valve when performing any type of engine service, during transport of the machine, and during storage.

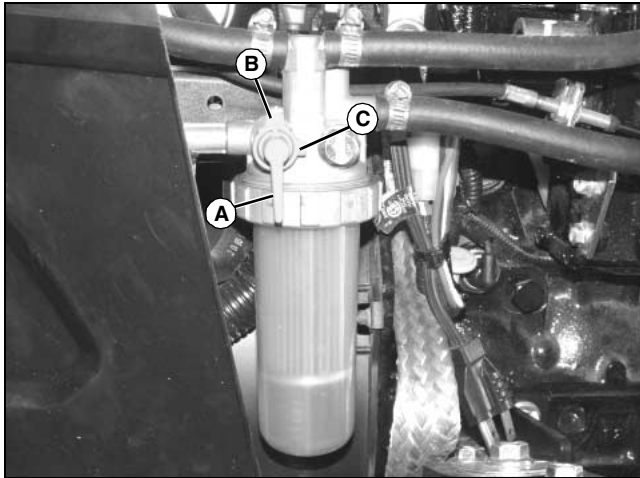

MX46281

1. Open or close fuel shut-off valve lever (A) as required:
 - **Open Valve:** Rotate valve lever pointer to the vertical position (B) marked "O".
 - **Close Valve:** Rotate valve lever pointer to the horizontal position (C) marked "C".

Starting the Engine



CAUTION: Avoid injury! Engine exhaust fumes contain carbon monoxide and can cause serious illness or death.

- Move the machine to an outside area before running the engine.
- Do not run an engine in an enclosed area without adequate ventilation.
- Connect a pipe extension to the engine exhaust pipe to direct the exhaust fumes out of the area.
- Allow fresh outside air into the work area to clear the exhaust fumes out.

1. Open the fuel shut-off valve.
2. Lock the park brake.

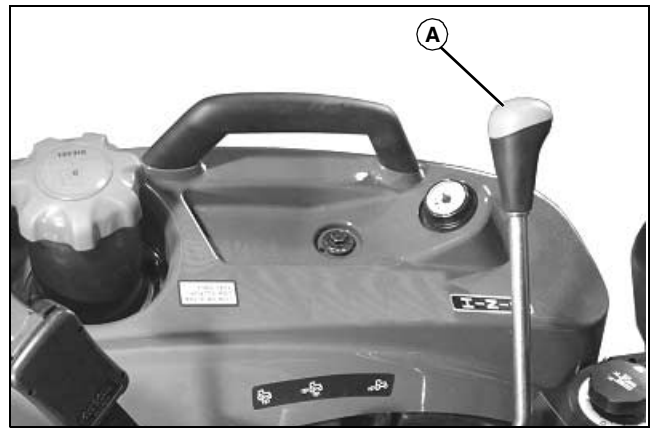

MX46287

3. Move the 2-speed range lever (A) to the N position.

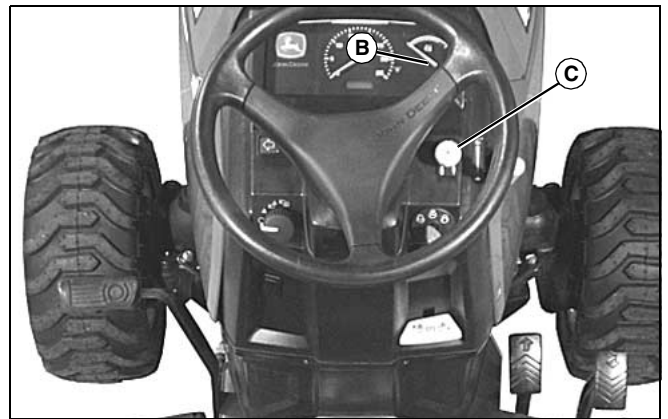

MX46285

4. Push PTO switch knob (B) down to the disengaged/off position.



CAUTION: Avoid injury! Check to be sure area is clear of any bystanders before lowering implements to the ground.

5. Lower any implements to the ground.
6. Set hand throttle lever (C) to the 1/2-3/4 fast position.
7. Turn ignition key switch to the ON position.
8. Check indicator lamps:
 - Engine oil pressure light will glow.
 - Engine preheater light will glow. When light goes out, engine is ready to start.
 - Alternator/battery charging light will glow.

Operating

IMPORTANT: Avoid damage! Starter may be damaged if starter is operated for more than 20 seconds at a time:

- Wait two minutes before trying again if engine does not start.

9. Turn key switch to START position. Release key when engine starts.

10. Check indicator lights:

- Engine oil pressure light should go out within 5 seconds.

NOTE: Set engine speed at full throttle if indicator light does not go out after 10 seconds.

- Alternator/battery charging light should go out within 10 seconds.
- If indicator lights stay on longer than the given time interval, stop engine and check for cause.

11. Set hand throttle lever to the 1/2 fast position for 1 minute without load.

Cold Weather Starting Aids

IMPORTANT: Avoid damage! Glow plugs and air heater are operational during cranking. Using ether or starter fluid during cranking will cause damage to engine.

Recommendations:

- Turn key to ON position for 5-10 seconds to activate glow plugs.
- Install optional engine coolant heater if you operate machine in temperatures below -18° C (0° F).

Warming and Idling the Engine

IMPORTANT: Avoid damage! In cold weather, run engine several minutes to allow engine oil and transmission oil to warm.

NOTE: It is normal for the engine to be louder and for blue-white exhaust smoke to be present during engine warm-up. The amount of exhaust smoke depends on air temperature.

Warming Engine:

- Lock the park brake.
- Set hand throttle lever to the 1/2 throttle position for 5 minutes without load.

Idling Engine:

- Adjust hand throttle lever rearward to set engine speed at 1575 ± 25 rpm (low idle speed).

Starting a Stalled Engine

IMPORTANT: Avoid damage! If engine stalls while operating under load, start engine immediately to prevent abnormal heat build-up in engine.

1. Move the transmission range shift lever to the N (neutral) position.
2. Push PTO switch knob down to the disengaged/off position.
3. Start engine. Continue with normal operation, or set engine speed at low idle speed for 1 or 2 minutes before stopping.

Stopping Machine

Normal Stopping

1. Remove foot from forward or reverse pedal.
2. Push PTO switch knob down to the disengaged/off position.



CAUTION: Avoid injury! Check to be sure area is clear of any bystanders before lowering implements to the ground.

3. Lower any implements to the ground.
4. Fully depress brake pedal.



CAUTION: Avoid injury! Always lock park brake and move transmission range shift lever to a position other than N (neutral) before leaving machine unattended. Transmissions will not prevent machine motion without the park brake locked.

5. Lock the park brake.

IMPORTANT: Avoid damage! Do not stop engine immediately after hard or extended operation. Keep engine running at low idle for about 2 minutes to prevent heat build-up.

6. Adjust hand throttle rearward to set engine speed at low idle speed. Allow engine to idle for 2 minutes.
7. Turn key switch to OFF position.

Operating

8. Remove key.
9. Wait for the engine and all moving parts to stop before leaving the operator's station.

Emergency Stopping

1. Remove foot from forward or reverse pedal.
2. Depress brake pedal.
3. Turn key switch to OFF position. Do not release brake pedal until all moving parts have stopped.
4. Lock the park brake.

Operating the Hydrostatic Transmission

IMPORTANT: Avoid damage! To prevent transmission damage, stop machine motion completely before shifting the range shift lever.

1. Start machine engine.

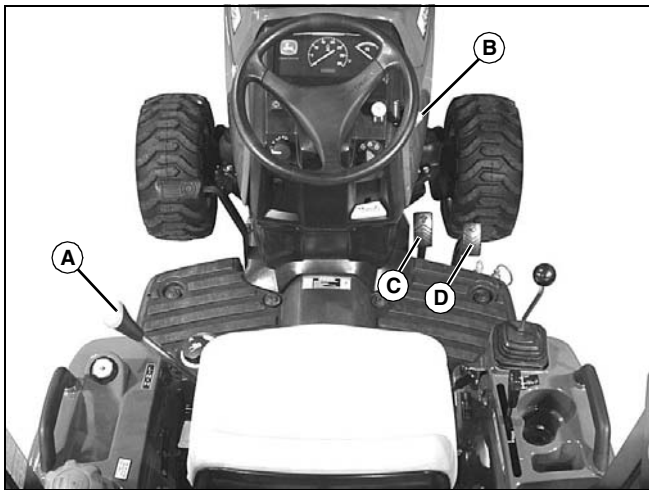

MX46284

2. Choose speed range with range shift lever (A) to match work application.

- **L** – Low speed operations such as tilling hard soil, mowing long grass or heavy hauling. Machine speed is decreased, but machine power is increased.
- **N** – Neutral position. Lever must be in the N (neutral) position when starting the engine.
- **H** – High speed operations such as light tilling and hauling, mowing short grass and transport. Machine speed is increased, but machine power is decreased.

3. Depress brake pedal.
4. Unlock park brake.
5. Release brake pedal.
6. Move throttle lever (B) forward until engine operates at

desired speed.

NOTE: When the travel pedal is released, the transmission will automatically return to neutral.

7. Slowly depress pedal (C) downward to travel forward. Slowly depress pedal (D) downward to travel in reverse.

- The farther either travel pedal is depressed, the faster the machine will travel.

8. Stop machine to change speed range.

Using Cruise Control - 1026R



CAUTION: Avoid injury! Use cruise control only in large, open areas. Shut off before turning or when in areas with many obstacles.

NOTE: The cruise control is only operational when the machine is traveling forward.

Engaging Cruise Control

1. Depress forward travel pedal until desired travel speed is reached.



MX46358

2. Lift cruise control lever (A) to engage.
3. Release forward travel pedal.

Disengaging Cruise Control

The cruise control can be disengaged in one of two ways:

- Depress brake pedal and push cruise control lever down.
- Increase travel speed slightly and push cruise control lever down.

Adjusting Cruise Control Travel Speed

To adjust travel speed:

- Increase travel speed by pressing forward travel pedal until desired speed is reached.
- Decrease travel speed by disengaging cruise control,

Operating

adjusting forward travel speed as desired and engage cruise control lever.

Using Differential Lock (Traction Assist)



CAUTION: Avoid injury! Driving at high speeds with the traction assist engaged may result in loss of steering control. Do not engage traction assist or turn with the traction assist engaged while operating machine at high speeds or on slopes.

The differential lock is used to provide better traction when rear wheels start to slip. Engaging differential lock will lock right and left side rear axles together and cause both rear wheels to turn at equal speeds for maximum traction.

IMPORTANT: Avoid damage! Using the traction assist function improperly can damage the transaxle:

- Reduce speed and allow drive wheels to rotate at same speed before engaging or disengaging traction assist.
- Disengage traction assist when driving on dry asphalt or concrete.
- Use traction assist only when necessary for improved ground engagement.

NOTE: Turning radius is increased when the differential lock is engaged.

Engaging Differential Lock

1. Stop or slow machine movement.

NOTE: Differential lock will remain engaged as long as rear wheel slippage occurs. If tires slip and regain traction repeatedly, hold down pedal with foot so differential lock remains engaged.

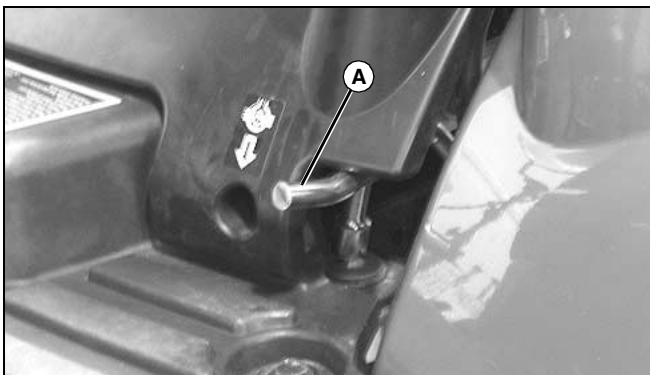

MX46288

2. Push down on differential lock pedal (A) to engage

differential lock.

Disengaging Differential Lock

1. Remove foot from differential lock pedal.

NOTE: Rear wheel slippage will keep differential lock engaged. Lock will automatically disengage when traction equalizes.

2. If lock does not disengage when removing foot from pedal, depress brake pedal to equalize traction, then release.

Using Mechanical Front Wheel Drive (MFWD)

Mechanical front wheel drive (MFWD) enables the powertrain to drive both front and rear axles for improved traction on difficult ground conditions and provides 4-wheel braking. MFWD can be engaged and disengaged on-the-go with light loads and on low traction surfaces.



CAUTION: Avoid injury! Use extra caution when driving on slopes. To increase traction and provide four-wheel braking, engage mechanical front wheel drive (MFWD) when driving on slopes. Be aware that MFWD can improve access to dangerously sloped terrain, thereby increasing the possibility of tipover.

To improve braking on sloped, icy, wet, or graveled surfaces, engage the MFWD. Add ballast to the tractor and travel at a reduced speed to avoid skidding and loss of steering control.

IMPORTANT: Avoid damage! Always disengage MFWD when driving on a paved surface.

Put the transmission levers in neutral to move the machine when the engine is not running.

Operating

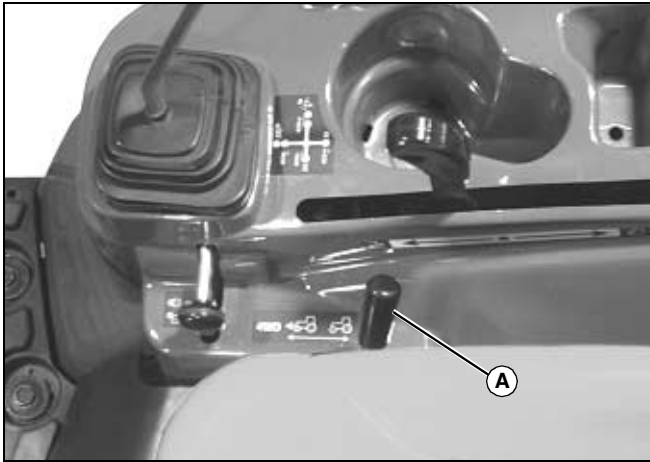

MX46289

NOTE: It may be necessary to reduce engine load to disengage front wheel drive.

Push MFWD lever (A) forward to engage MFWD. Pull lever rearward to disengage MFWD.

Tips for Operating MFWD:

- Maintain front tire pressure at maximum allowable level to ensure proper tire performance in all field conditions.
- Engage MFWD to provide four-wheel braking.
- Disengage MFWD when driving machine to or from work site to increase front tire life.

Using the Power-Take-Off (PTO) Safely

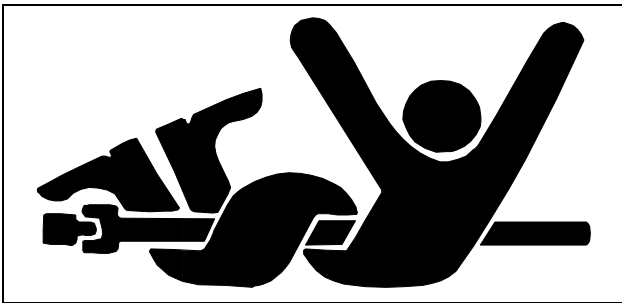

CAUTION: Avoid injury! Stay clear of rotating drivelines:

- Entanglement in rotating driveline can cause serious injury or death.
- Keep hands, feet and clothing away.
- Make sure that all shields are installed and used properly.
- Stop the engine and be sure PTO driveline is stopped before getting near it.

Checking PTO Driveshaft Length

IMPORTANT: Avoid damage! The PTO driveshaft is a standard length. Certain driveshaft applications may cause contact with transmission. Driveshaft length may need to be shortened to avoid contact.

Checking PTO Driveshaft

NOTE: Check PTO driveshaft movement before operating implement.

1. Park machine safely. (See Parking Safely in the Safety section.)
2. Install driveshaft on implement.
3. Install implement on tractor. Do not install driveshaft on tractor.
4. Check the fully shortened position of the driveshaft.
 - a. Push the driveshaft in to its shortest length by hand.

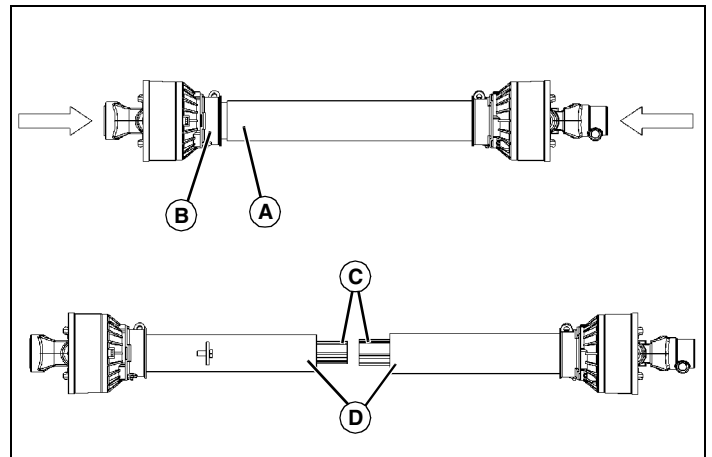

MX22555

- b. Check the area where the outer tube shield (A) meets the shield bell (B).
 - c. If the outer tube shield does not touch the shield bell, make a mark on the inner tube where the outer tube shield ends.
5. Install driveshaft on tractor and adjust the center link to level the implement for operating while in lowered position. See Using 3-Point Hitch in OPERATING Section.
 6. Have an observer stand a safe distance from the implement to tell you when the driveshaft is fully shortened.
 7. Set the tractor at low idle and raise the implement, stopping when the observer sees the outer tube shield reach the mark on the inner tube, or the outer tube shield touches the shield bell.
 - If the implement is fully raised, and the driveshaft does not reach the fully shortened position, with either the outer tube shield at the mark or touching the bell shield, the driveshaft is ready for operation.

Operating

- If the driveshaft reaches the fully shortened position before the implement is fully raised, the driveshaft will need to be shortened.

Shortening the PTO Driveshaft



CAUTION: Avoid injury! Do not use the driveshaft with an implement if the rotating shaft is not completely covered. Check to make sure shaft is covered before operating.

1. See your John Deere dealer for assistance, or remove 25mm (1 in.) from the ends of the driveshaft (C) and the ends of the shield tubes (D).
2. Check driveshaft length again, and shorten further if needed.

Using Rear and Mid Power-Take-Off (PTO)

IMPORTANT: Avoid damage! Use rear mounted equipment rated for 540 rpm. Do not operate mid or rear PTO over 540 RPM mark on tachometer.

NOTE: PTO operation for this machine is not intended to be used when the operator is off the seat. The safety interlock system will stop the engine and all implements if the PTO is operating and the operator leaves the seat.

Engaging the PTO

1. Sit on operator's seat.
2. Lock the park brake.
3. Move the 2-speed range lever to the N position.

NOTE: The starter will not crank if the PTO switch knob is in any engaged/on position.

If the operator leaves the seat with the engine running and the PTO engaged, the safety interlock system will stop the engine and all implements.

4. Start the engine.
5. Set engine speed to 1500 rpm or less.

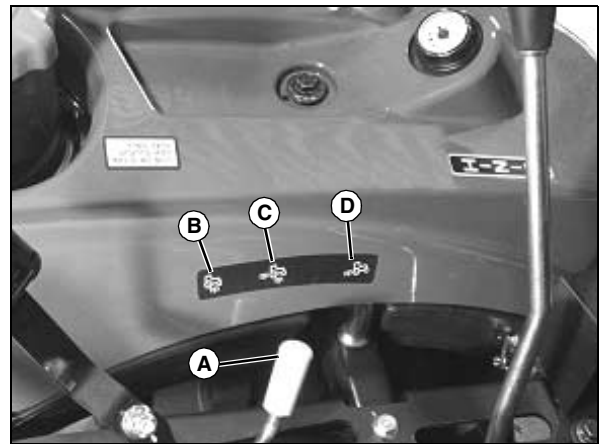

MX46287

6. Move the PTO control lever (A) to desired operating position.
 - Position (B) - Mid PTO only.
 - Position (C) - Mid and Rear PTO
 - Position (D) - Rear PTO only.
7. Pull PTO switch knob up to the engaged/on position.
8. Adjust the hand throttle lever forward to the desired speed for the implement used.

NOTE: The tachometer PTO marker indicates a PTO speed at an engine speed of 3200 rpm.

- Mid PTO speed will be 2100 rpm and rear PTO speed will be 540 rpm.
- If PTO shuts off during use, turn off engine and push down to turn off PTO switch. Lock park brake. Allow engine to cool. Check coolant level and add coolant if necessary. Clean debris away from radiator cooling fins. Sit on seat, and start engine. Pull PTO up to on position. If PTO still does not engage, see your local John Deere Dealer for service.

Disengaging the PTO

1. Adjust engine rpm to low idle.
2. Push PTO switch knob down to the disengaged/off position.

Operating

Using Rear Hitch

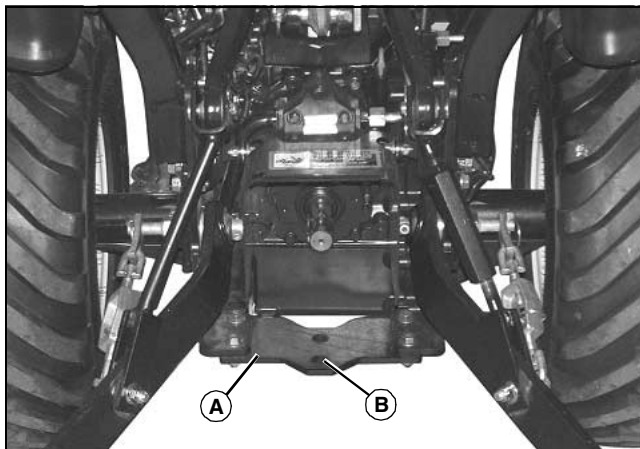

MX46282

The rear hitch plate (A) provides a single fixed mounting position (B) for towing.



CAUTION: Avoid injury! Hitch towed loads only to the rear hitch plate to avoid rearward upset. Do not use a safety chain for towing loads.

Maximum Hitch Loads

Certain heavy equipment such as a loaded single-axle trailer can place excessive strain on the hitch. Strain is greatly increased by speed and rough ground. Do not exceed 255 kg (562 lb) maximum static vertical load on the rear hitch at position (B).

Using 3-Point Hitch

NOTE: The 3-point hitch on your machine is classified as a limited Category 1 hitch.

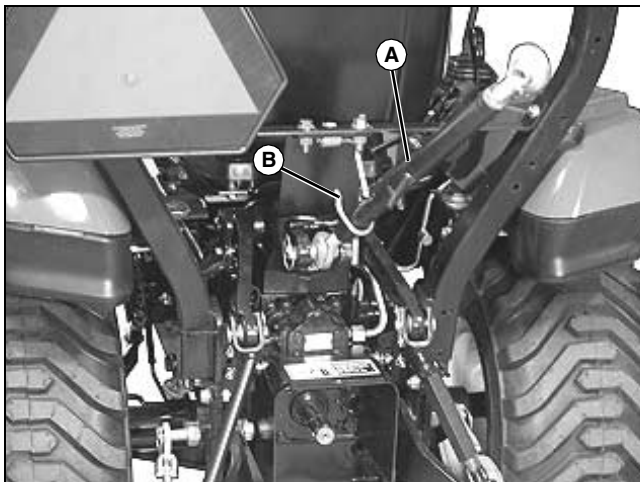

MX46356

- Place center link (A) in storage hook (B) when hitch is not

in use.

Using Rockshaft Control Lever - 1023E

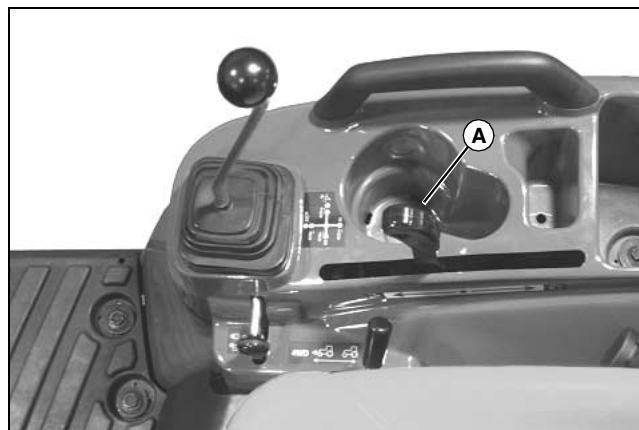

MX46289

Use rockshaft control lever (A) to raise and lower equipment attached to the 3-point hitch.

Lower Implement: Push lever forward to lower implement. Lever will automatically return to neutral position (center) when released.

Raise Implement: Pull lever rearward to raise implement. Lever will automatically return to neutral position (center) when released.

Using Rockshaft Control Lever - 1026R

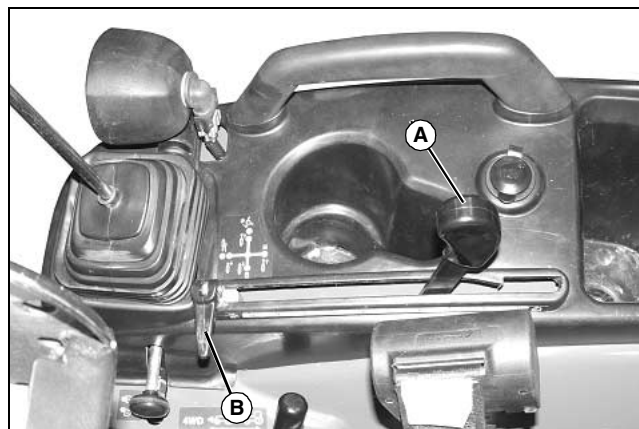

MX46342

Use rockshaft control lever (A) to raise and lower equipment attached to the 3-point hitch.

- To lower implement: Push lever forward.
- To raise implement: Pull lever rearward.

Position control can be used to maintain the operating depth of the implement. To adjust the operating depth:

1. Unlock the depth stop lever (B) and slide toward the front of the console completely.
2. Operate the implement for several minutes to determine the desired operating depth.

Operating

3. Slide the depth stop against the rockshaft control lever and lock it in position.

NOTE: The calibrated label settings below the rockshaft control lever are for reference only and do not signify specific operating depths.

The implement will operate in same position each time the rockshaft control lever is pushed against the depth stop.

Using Rate of Drop/Lock Valve

The rate of drop/lock valve controls the rate of rockshaft drop when the rockshaft control lever is operated. This provides direct rate of drop control for 3-point hitch mounted implements. The valve can also be used to hydraulically lock the rockshaft (three-point hitch) in a desired position.

CAUTION: Avoid injury! Excessive rate-of-drop may cause injury or damage. Fully lowering implement should take at least 2 seconds.

IMPORTANT: Avoid damage! To prevent overheating hydraulic oil and damaging machine, do not raise rockshaft when drop/lock valve is closed.

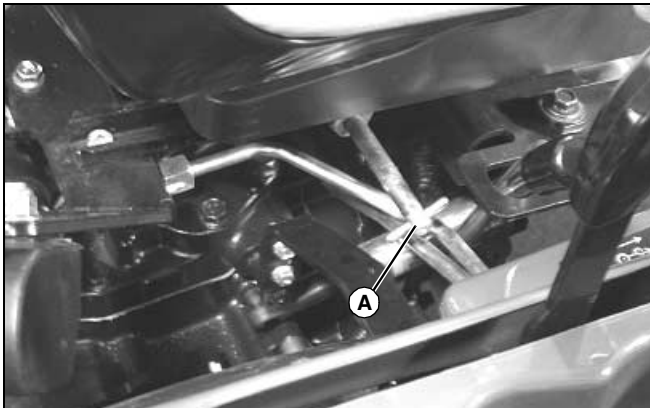

MX46290

Picture Note: 1023E Shown

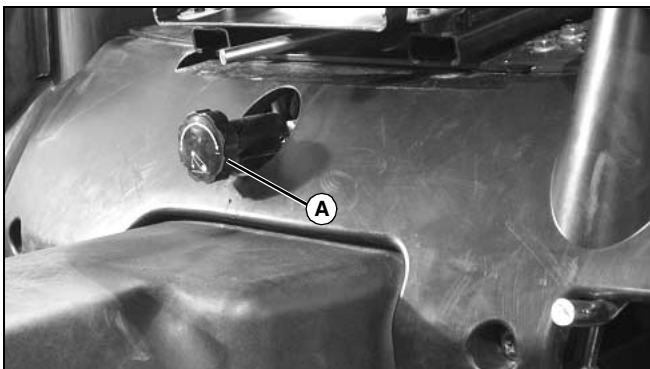

MX46359

Picture Note: 1026R Shown

Increase Rate of Drop: Rotate drop/lock valve knob (A) counter-clockwise to make drop faster.

Decrease Rate of Drop: Rotate drop/lock rate valve knob (A) clockwise to make drop slower.

CAUTION: Avoid injury! Do not use the rockshaft drop/lock valve for holding an attachment in raised position for service work. Loss of hydraulic pressure could result in sudden drop of attachment. Lower attachment onto blocks or remove from machine before servicing.

Lock 3-Point Hitch: Rotate drop/lock rate valve knob clockwise until tight.

Unlock 3-Point Hitch: Rotate drop/lock rate knob counter-clockwise.

Using the Draft Links

CAUTION: Avoid injury! Look down and behind before and while backing. Clear area of all bystanders before backing machine.

1. Slowly back machine into position to align draft links with implement lift brackets.
2. Park machine safely. (See Parking Safely in the SAFETY section.)



MX46283

3. Connect draft links (A) to the implement.
4. Secure implement with lynch pins.

Leveling Implement Front-to-Rear

1. Park machine safely. (See Parking Safely in the Safety section.)

Operating

NOTE: When the 3-point hitch is not being used, return center link to storage hook (A).

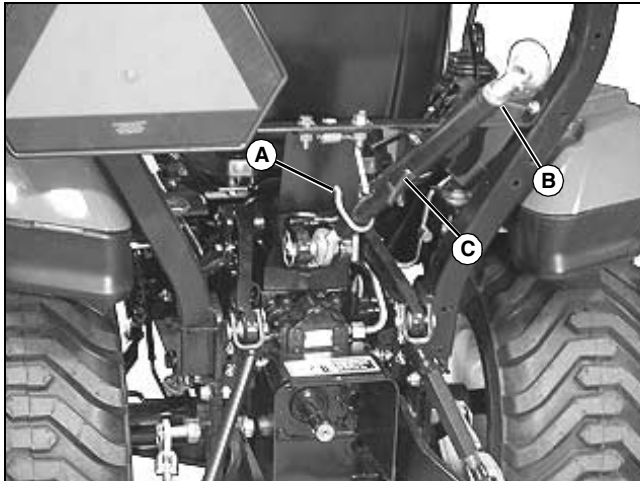

MX46356

2. Lower implement to ground to relieve pressure on center link.
3. Loosen locknut (B).

IMPORTANT: Avoid damage! Do not turn center link body past the stops, or threads may be damaged.

4. Rotate center link body (C) to lengthen or shorten the center link as needed.
5. Tighten locknut (B).

Leveling Implement Side-to-Side

1. Lower any rear mount implement to the ground.
2. Park machine safely. (See Parking Safely in the Safety section.)



MX46283

3. Loosen locknut (A).
4. Rotate lift link body (B) to raise or lower draft link until 3-point hitch mounted implement is level from side-to-side.

5. Tighten locknut (A).

Adjusting Implement Side-to-Side Sway

NOTE: Check implement operator's manual procedure for adjusting sway links. When sway links have been properly adjusted, side sway of implement is controlled by position of links.

1. Lower any rear mount implement to the ground.
2. Park machine safely. (See Parking Safely in the SAFETY section.)

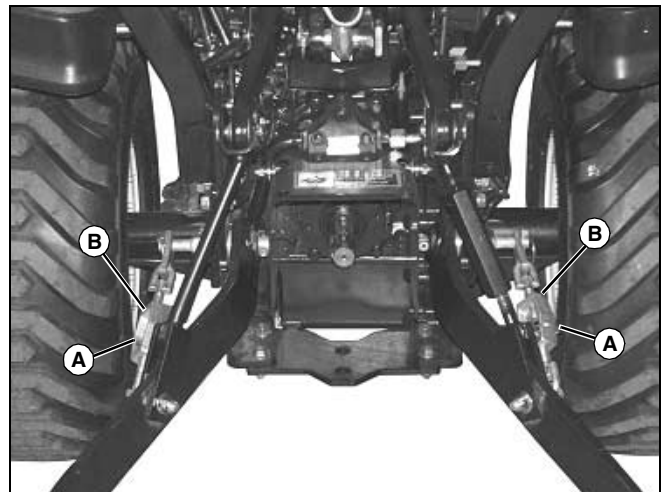

MX46283

3. Remove locking ring (A).
4. Rotate turnbuckle (B) to adjust length.
5. Install locking ring.

Using Optional iMatch™ Quick-Attach Hitch System

The optional quick-attach hitch fits all Category I implements designed to the ASAE Cat I standard for quick-attach hitches.

Operating

Installing Hitch

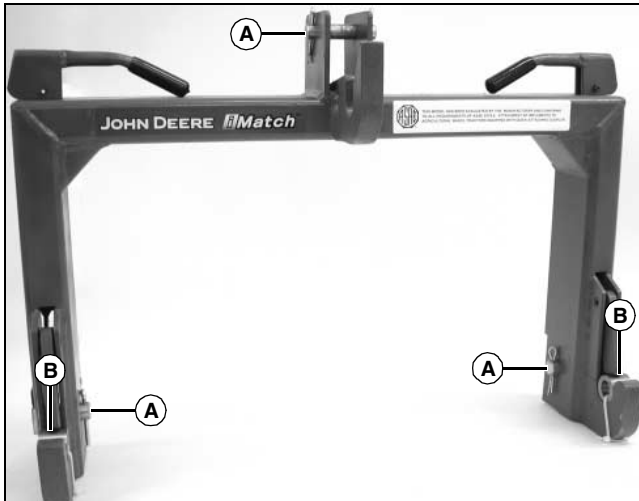

MX10720

1. Remove three drilled pins (A) and two bushings (B) from quick-attach hitch.
2. Use machine rockshaft control lever to fully lower 3-point hitch draft links.
3. Park machine safely. (See Parking Safely in the SAFETY section.)
4. Position quick-attach hitch near draft links and adjust 3-point hitch sway links to align draft links with quick-attach hitch.
5. Install quick-attach hitch on draft links using drilled pins.
6. Install 3-point hitch center link on quick-attach hitch using center link quick-lock pin and drilled pin.

Connecting Implement

1. Install two bushings included with quick-attach hitch on drilled pins in implement draft link lift brackets.

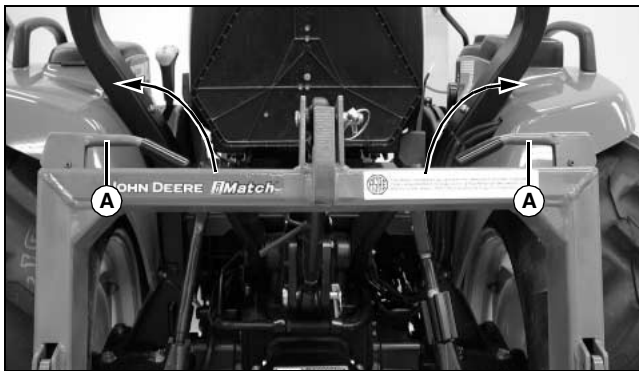

MX10706

2. Move levers (A) on quick-attach hitch to unlocked position.
3. Back machine into position and align quick-attach hitch with implement lift brackets.
4. Use rockshaft control lever to position quick-attach hitch

under lift brackets and lift implement from ground.

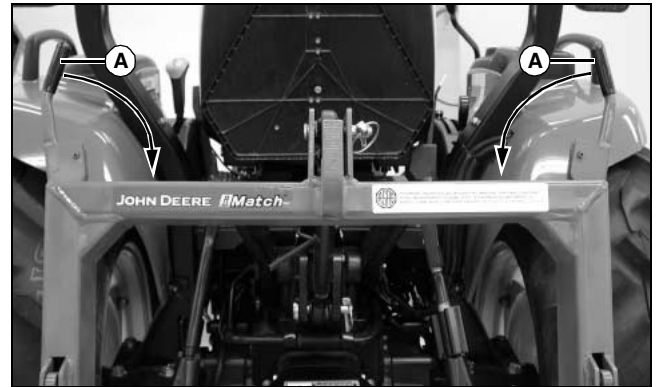

MX10713

5. Fully raise implement. Move levers (A) on quick-attach hitch to locked position.

Connecting Implement Hydraulic Hoses



CAUTION: Avoid injury! Escaping fluid under pressure can penetrate the skin causing serious injury. Relieve hydraulic system pressure by moving hydraulic controls in all directions before connecting or disconnecting hydraulic lines.

1. Park machine safely. (See Parking Safely in the SAFETY section.)
2. Relieve all hydraulic pressure by moving SCV lever rearward-to-forward and side-to-side several times.
3. Refer to implement operator's manual for instructions on connecting hydraulic hoses to couplers.

Operating

Using Hydraulic Dual Selective Control Valve (SCV)



CAUTION: Avoid injury! Escaping fluid under high pressure can penetrate the skin and cause serious injury. Avoid the hazard by relieving pressure before connecting hydraulic or other lines. Tighten all connections before applying pressure.

- Search for leaks with a piece of cardboard. Protect hands and body from high pressure fluids.
- If an accident occurs, see a doctor immediately. Any fluid injected into the skin must be surgically removed within a few hours or gangrene may result. Doctors unfamiliar with this type of injury should reference a knowledgeable medical source. Such information is available from Deere & Company Medical Department in Moline, Illinois, U.S.A. In the United States and Canada only, this information may be obtained by calling 1-800-822-8262.

This machine series is equipped with an hydraulic Selective Control Valve (SCV) and hydraulic outlets to operate hydraulically-driven implements.

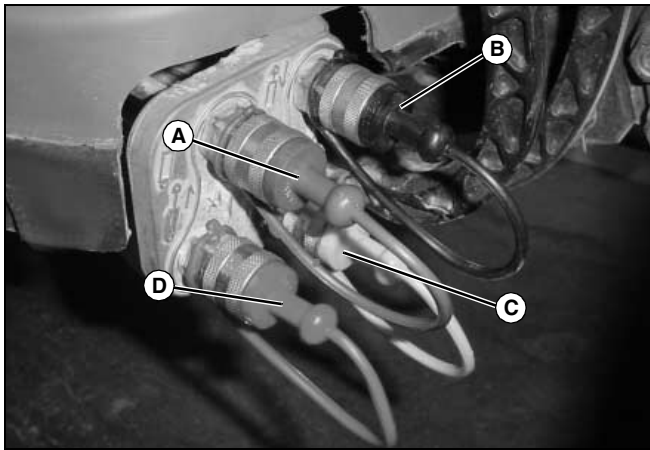

MX46291

- A - Blue**
- B - Black**
- C - Yellow**
- D - Red**

The machine-mounted hydraulic outlets are female quick couplers color coded for easy hookup.

Implement hydraulic hoses are also color coded. Match the color coded hose ends to the color coded hydraulic couplers on the machine when making connections.

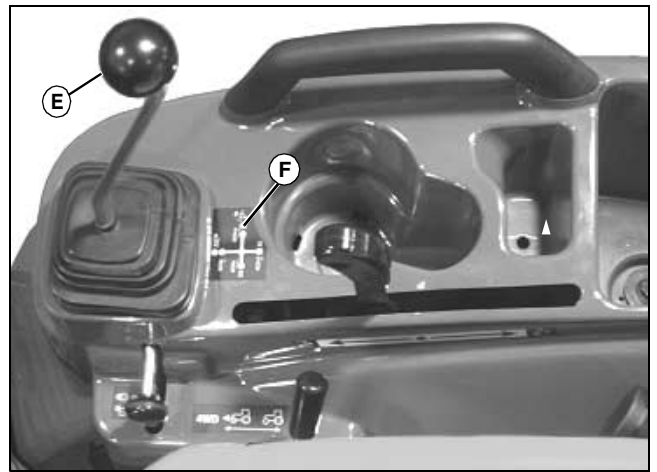

MX46289

When the implement hydraulic hoses are connected to the yellow and black couplers, move the dual SCV lever (E) left to divert fluid to the yellow connector line and return through the black connector line. Move the lever right to divert fluid to the black connector line and return through the yellow connector line. Move the lever to the full right or “regen position” to divert fluid to the black connector line for faster loader bucket dumping.

When the implement hydraulic hoses are connected to the red and blue couplers, move the dual SCV lever (E) rearward to divert fluid to the blue connector line and return through the red connector line. Move the lever forward to divert fluid to the red connector line and return through the blue connector line. Move the lever to the full forward or “float” position to remove pressure in both connector lines and allow fluid to flow back and forth between the lines. The lever may be left in the “float” position.

Refer to information label (F) for assistance. See your implement Operator’s Manual for implement functions which correspond to lever positions.

IMPORTANT: Avoid damage! To prevent contamination of female quick couplers, color-coded hose ends should be installed in the couplers when not being used.

Operating

Using Selective Control Valve (SCV) Lock Lever

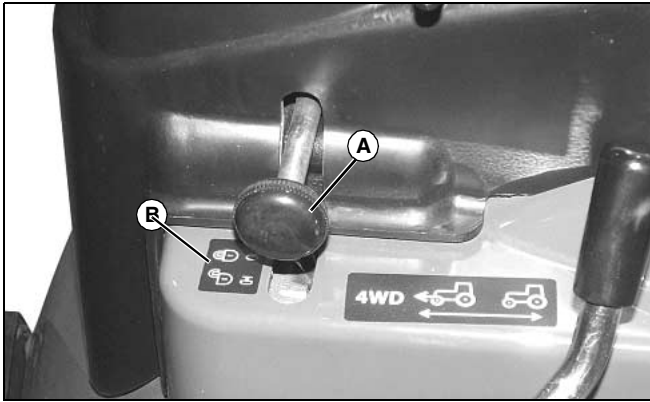

MX46295

Picture Note: SCV lock lever shown in the unlocked position.

- Pull the lock lever (A) to allow SCV lever movement in all directions. Operation of the SCV is unlocked.
- Push the lock lever (A) to prohibit SCV lever movement in all directions. Operation of the SCV is locked.
- Operation of the lock lever is indicated on label (B).

Ballasting Machine



CAUTION: Avoid injury! Ballasted machine may become unstable when attachment is raised. Always drive slowly over uneven ground and when turning with raised attachment.

IMPORTANT: Avoid damage! Do not overload tires. Do not exceed tire maximum inflation pressure or maximum load capacity.

Add weight to machine front end if needed for stability. Heavy pulling and heavy rear mounted implements tend to lift front wheels. Add enough ballast to maintain steering control and prevent tip over. Remove weight when it is no longer needed.

IMPORTANT: Avoid damage! Remove ballast from machine when no longer needed.

Tire Capacities

Use the following charts to determine the tire maximum inflation pressure and load capacity.

Verify maximum tire inflation pressure and maximum load information if embossed into the tire side wall.

Maximum Inflation Pressures for Rear Tires

Tire Size	Ply	kPa (psi) Loaded	Maximum Load Capacity Kg (lb)
26 x 12.00-12 R4	4	138 (20)	807 (1780)
26 x 12.00-12 R3	4	138 (20)	807 (1780)

Maximum Inflation Pressures for Front Tires

Tire Size	Ply	kPa (psi) Loaded	Maximum Load Capacity kg (lb)
18 x 8.5-10 R4	4	152 (22)	376 (829)
18 x 8.5-10 R3	4	152 (22)	376 (829)

* Maximum pressure following tire manufacturer's specifications.

**Maximum load capacity for single tire.

Using Optional Rear Cast Iron Wheel Weights

1. Mount rear wheels in the wide position for improved stability.



CAUTION: Avoid injury! Machine component or attachment is heavy. Use a safe lifting device or get an assistant to help lift, install or remove component or attachment.

2. Fasten weight to each rear wheel using a safe lifting device. A total of three weights per wheel may be used. See your implement operator's manual for installation and number of weights to use.

Rear wheel weights are available from your John Deere Dealer.

Using Optional Rear Ballast Box



CAUTION: Avoid injury! To improve front loader-machine stability, use of ballast box is recommended. Use ballast as recommended in loader operator's manual.

The rear ballast box is used for carrying ballast on the 3-point hitch. Approximate weight of different materials is given in the implement operator's manual.

Operating

Using Liquid Weight in Tires

CAUTION: Avoid injury! Installing liquid ballast requires special equipment and training. Injury may occur from exploding tire. Have the job done by your John Deere dealer or a tire service store.

IMPORTANT: Avoid damage! Cover rim completely with solution to avoid corrosion, but never more than 90 percent full. More solution would leave too little air space to absorb shocks. Damage to tire could occur.

NOTE: Use of alcohol as ballast is not recommended. Calcium chloride solution is heavier and more economical.

A solution of water and calcium chloride provides safe economical ballast, and will prevent freezing. If used properly, it will not damage tires, tubes, or rims.

A mixture of 0.4 kg of calcium chloride per liter of water (3.5 lb/gal), will not freeze solid above -45° C (-50° F).

Fill tubeless tires at least to valve stem level (minimum 75% full). Less solution would expose part of rim, possibly causing corrosion.

Tube-type tires may be filled to any level below 90%.

Using Optional Front Weights

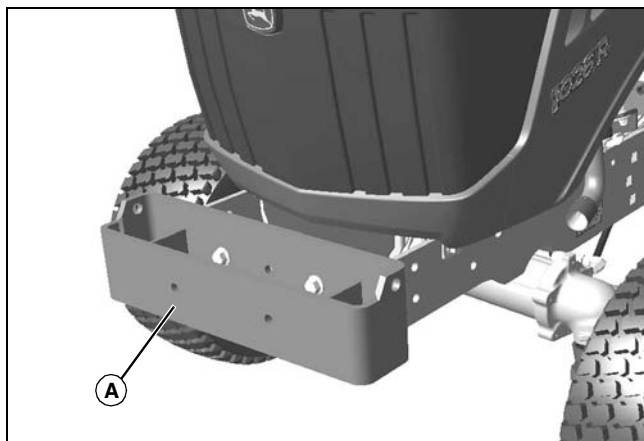

MX46389

IMPORTANT: Avoid damage! Do not install weights on front bumper plate, damage to can occur to the front grille. Use optional bolt-on weight bracket for front weights.

Front weight bracket (A) is an optional bolt-on to the machine frame. The bracket will hold up to seven Quick-Tatch™ weights.

Each weight is 19 kg (42 lb).

Quick-Tatch weights and attaching hardware are available at your John Deere dealer.

See your implement operator's manual for installation and required number of weights to use.

Transporting Machine on Trailer

CAUTION: Avoid injury! Use extra care when loading or unloading the machine into a trailer or truck.

Close fuel shut-off valve, if your machine is equipped.

IMPORTANT: Avoid damage! Transporting a machine on a trailer or on a truck bed at high speeds can result in hood or engine cover raising and possibly coming off machine if not secured.

- Position machine on trailer so hood or engine cover opens from rear of trailer to prevent wind from blowing hood or cover open.
- Secure hood or engine cover with existing machine locks or latches.
- Secure hood or engine cover with tie down straps if no locks or latches exist.

NOTE: Use a heavy-duty trailer to transport your machine.

1. Drive or back machine onto trailer so hood or engine cover opens from rear of trailer.
2. Lower any implements to trailer deck.
3. Lock the park brake.
4. Stop the engine.
5. Remove the key.
6. Close the fuel shut-off valve.
7. Fasten machine to trailer with heavy-duty straps, chains, or cables. Both front and rear straps must be directed down and outward from machine. Trailer must have signs and lights as required by law.

Operating

Transporting Machine

Driving Machine Safely on Roads



CAUTION: Avoid injury! Use caution when operating machine at transport speeds. Reduce speeds if towed load weighs more than machine. Consult towed equipment operator's manual for recommended transport speeds.

Use additional caution when transporting towed loads under adverse surface conditions, especially when turning, and on inclined surfaces.

Use of warning lights and turn signals are recommended when traveling on public roads unless prohibited by state or local regulations. An implement safety lighting kit is available from your John Deere dealer.

Observe the following precautions when operating the machine on a road:

- Make sure brake linkage is properly adjusted.
- Make sure Slow Moving Vehicle (SMV) emblem and warning lights are clean and visible. If towed or rear-mounted equipment obstructs these safety devices, install SMV emblem and warning lights on equipment.
- Turn on flashing warning lights and headlights, except if prohibited by law.
- Secure towed loads with locked hitch pins and safety chains.
- Drive slowly enough to maintain safe control at all times. Slow down for hillsides, rough ground, and sharp turns, especially when transporting heavy implements.
- If equipped, disengage the MFWD to reduce tire wear.
- Never coast machine downhill.

Pushing or Towing Machine



CAUTION: Avoid injury! Never tow machine faster than 16 km/h (10 mph). If possible, have someone operate steering and brakes of towed tractor.

IMPORTANT: Avoid damage! Push or tow machine for short distances only.

1. Push PTO switch knob to the disengaged/off position.
2. Disengage differential lock.
3. Unlock the park brake.
4. Place the range shift lever in the N (neutral) position.

5. Disengage the MFWD.

6. Be prepared to use the brake pedal to slow or stop machine.

Towing Loads



CAUTION: Avoid injury! Stopping distance increases with speed and weight of towed load, and on slopes. Towed loads with or without brakes that are too heavy for the machine or are towed too fast can cause loss of control. Consider the weight of the equipment and its load.

Observe these recommended maximum road speeds, or local speed limits which may be lower:

• **If towed equipment does not have brakes, do not travel more than 32 km/h (20 mph) and do not tow loads more than 1.5 times the tractor weight.**

• **If towed equipment has brakes, do not travel more than 40 km/h (25 mph) and do not tow loads more than 4.5 times the machine weight.**

Ensure the load does not exceed the recommended weight ratio. Add ballast to recommended maximum for machine, lighten the load, or get a heavier towing unit. The machine must be heavy and powerful enough with adequate braking power for the towed load. Use additional caution when towing loads under adverse surface conditions, when turning, and on inclines.

1. Hitch the towed load only to the rear hitch plate.
2. Connect safety chains to the lower draft arm crossbar and to the towed load. Provide only enough slack to permit turning.
3. Before descending a hill, shift to a gear low enough to control machine travel speed without having to use the brake pedal to brake the machine and installed implements.

Operating

Using Safety Chain



CAUTION: Avoid injury! Hitch towed loads only to the rear hitch plate to avoid rearward upset. Do not use a safety chain for towing loads.

IMPORTANT: Avoid damage! Secure the towed load to the rear hitch plate. Safety chains are designed to help control the towed load should it separate from the hitch plate.

Use a chain with a strength rating greater than the gross weight of the towed load.

Replace or repair the safety chain if one or more links or fittings are broken, stretched or damaged.

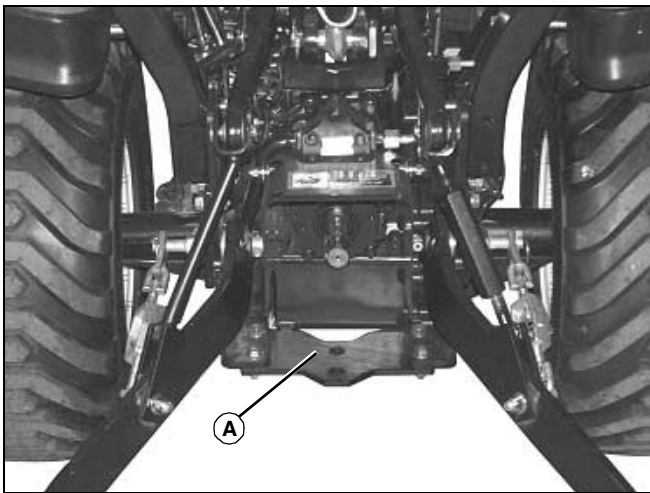

MX46283

1. Secure the safety chain around the rear hitch plate (A).
2. Remove the safety chain and store when not in use.

Raising and Lowering ROPS



CAUTION: Avoid injury! Always wear seat belt when operating machine with folding Roll-Over Protective Structure (ROPS) in upright position. Do not jump from machine if machine tips.

If ROPS must be folded to operate in a low clearance area, do not use seat belt. Raise ROPS and use seat belt as soon as conditions permit.

Lowering ROPS Crossbar

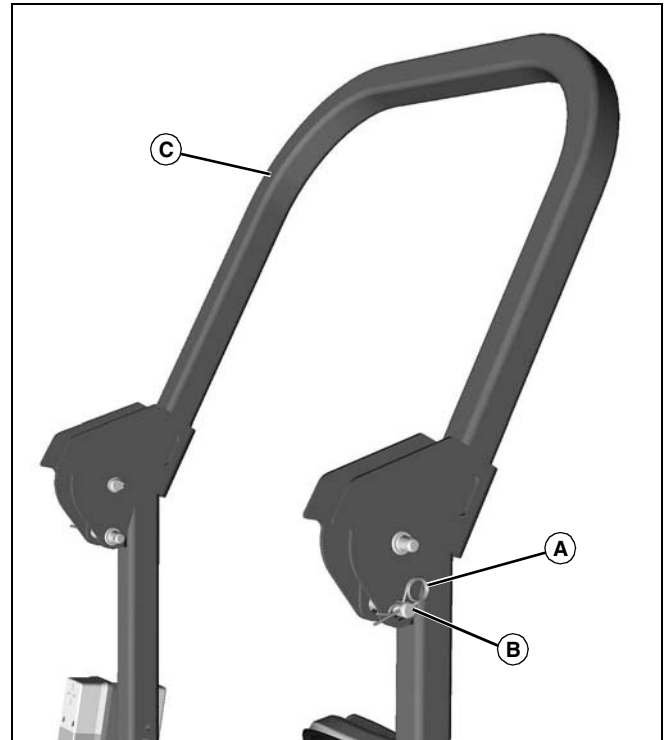

MX48806

1. Remove spring locking pin (A) and drilled pin (B) on each side of the ROPS.
2. Carefully lower ROPS crossbar (C) about half way down.

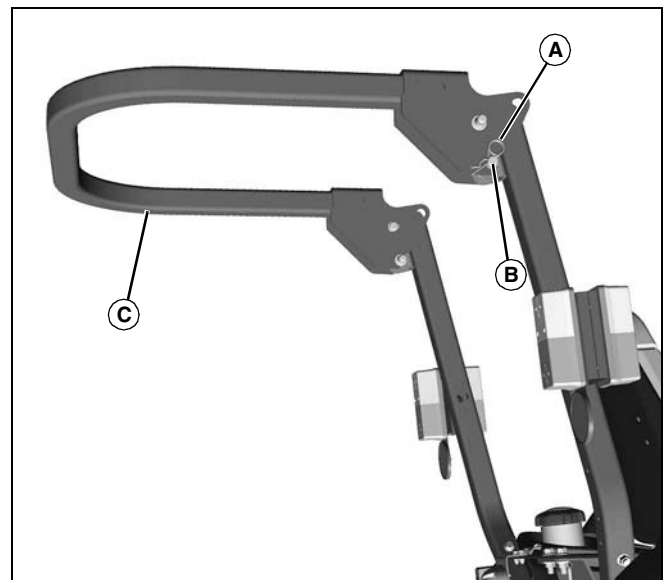

MX48807

3. Install drilled pins (B) and spring locking pins (A) and lower crossbar (C) onto drilled pins (B).

Raising ROPS Crossbar

1. Raise the crossbar just enough to remove spring locking pins (A) and drilled pins (B) on each side of the ROPS.

Operating

2. Carefully raise ROPS crossbar (C) to the operating position.
3. Align crossbar bracket holes with support bracket holes on each side of the ROPS.
4. Install drilled pins (B) and spring locking pins (A) to lock crossbar (C) in the raised position.

Replacement Parts

Service Literature

If you would like a copy of the Parts Catalog or Technical Manual for this machine call:

- **U.S. & Canada:** 1-800-522-7448.
- **All Other Regions:** Your John Deere dealer.

Parts

We recommend John Deere quality parts and lubricants, available at your John Deere dealer.

When you order parts, your John Deere dealer needs the serial number or product identification number (PIN) for your machine or attachment. These are the numbers that you recorded in the Product Identification section of this manual.

Order Service Parts Online

Visit <http://JDParts.deere.com> for your Internet connection to parts ordering and information.

Service Intervals

Servicing Your Machine

IMPORTANT: Avoid damage! Operating in extreme conditions may require more frequent service intervals:

- Engine components may become dirty or plugged when operating in extreme heat, dust or other severe conditions.
- Engine oil can degrade if machine is operated constantly at slow or low engine speeds or for frequent short periods of time.

Please use the following timetables to perform routine maintenance on your machine.

As Needed

- Replace alternator belt.
- Replace air filter elements (See restriction indicator on 1026R).
- Replace light bulbs.
- Replace fuses.
- Clean and replace battery.
- Replace radiator hoses and clamps.
- Check tire air pressure.
- Clean fuel tank overfill reservoir.
- Drain water and sediment from fuel sediment bowl, and service water separator.
- Check and clean front grille and side screens.
- Check and clean radiator cooling screen.
- Clean debris from engine compartment.

After First 10 Hours

- Check wheel bolt torque.

Every 10 Hours or Daily

- Test safety systems.
- Check engine oil level.
- Check transmission oil level.
- Check air filter elements, rubber dust valve, and restriction indicator (1026R).
- Check radiator coolant level.

After First 50 Hours

- Change transmission oil and filter.
- Clean transmission suction screen.

Every 50 Hours

- Check tire air pressure.
- Clean and check battery.
- Check front axle oil level.
- Lubricate machine.

Every 200 Hours

- Change engine oil and filter.
- Change transmission oil and filter.
- Clean transmission suction screen and internal magnets.
- Check and service air filter elements. Check and service air filter elements when restriction indicator is red (1026R).
- Clean radiator and oil cooler fins.
- Inspect alternator belt.
- Check wheel bolt torque.

Every 400 Hours

- Replace air filter elements.
- Replace fuel filters.

Every 600 Hours

- Check radiator coolant freeze point and clarity of coolant.
- Check engine low idle speed.
- Check air intake, hoses, and clamps.
- Change front axle oil.
- Check brake adjustment.

Annually

- Clean radiator and oil cooler fins.
- Check radiator coolant freeze point and clarity of coolant.
- Check and service air filter elements. Check and service air filter elements when restriction indicator is red (1026R).

Service Intervals

- Change engine oil and filter if less than 200 hours of operation.
- Drain water from fuel tank and replace fuel filters.
- Check all hoses and clamps.
- Check battery electrolyte level.

Every 1200 Hours

- Check engine valve clearance. See your John Deere dealer.

Every Two Years or 2000 Hours

- Flush and replace factory coolant. Flush cooling system and replace coolant with John Deere COOL-GARD engine coolant.
- Service fuel injection nozzles.

Service Lubrication

Grease

IMPORTANT: Avoid damage! Use recommended John Deere greases to avoid component failure and premature wear.

The recommended John Deere greases are effective within an average air temperature range of -29 to 135 degrees C (-20 to 275 degrees F).

If operating outside that temperature range, contact your Servicing dealer for a special-use grease.

The following greases are preferred:

- John Deere Multi-Purpose SD Polyurea Grease
- John Deere Multi-Purpose HD Lithium Complex Grease

If not using any of the preferred greases, be sure to use a general all-purpose grease with an NLGI grade No.2 rating.

Wet or high speed conditions may require use of a special-use grease. Contact your Servicing dealer for information.

The following lubricant is preferred:

- SUPER LUBE® lubricant.¹

Lubricating Machine Grease Fittings

- **Extremely Wet and Muddy Conditions** - Lubricate machine grease fittings (A) every 10 hours of operation or on a daily basis.
- **All Other Conditions** - Lubricate machine grease fittings every 50 hours of operation.

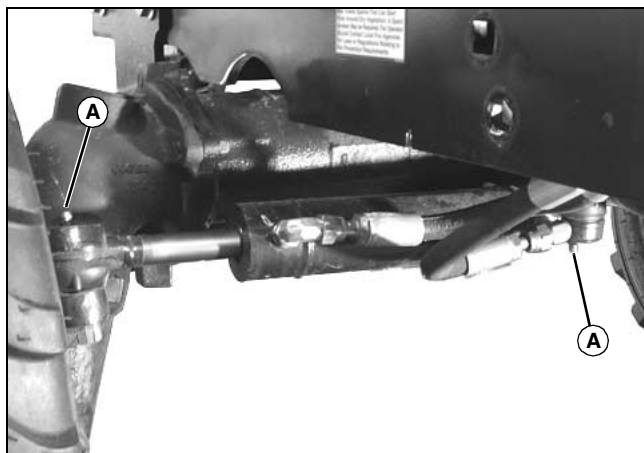

MX46345

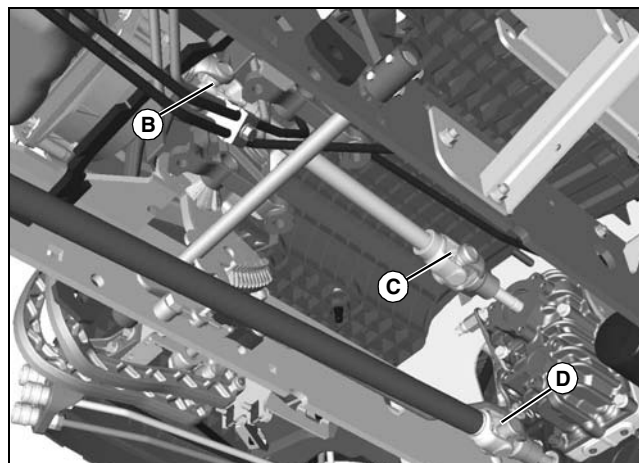

MX46798

Picture Note: Parts have been removed for better view.

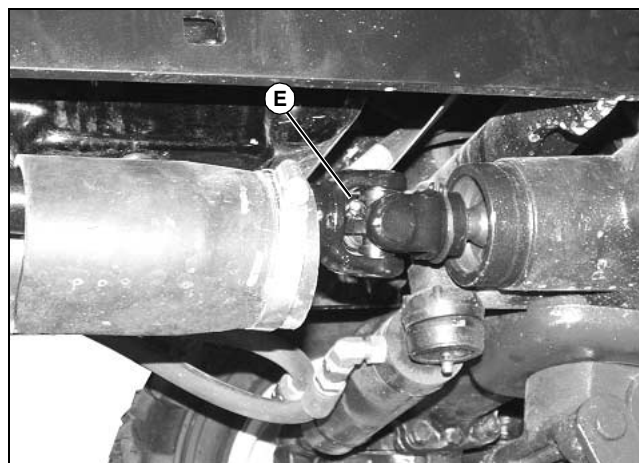

MX46347

Picture Note: Clamp loosened and boot pulled back for better view.

- A - Power Steering Cylinder
- B - Main Driveline - Front
- C - Main Driveline - Rear
- D - MFWD Driveline - Rear
- E - MFWD Driveline - Front

1. SUPER LUBE is a registered trademark of Synco Chemical Corp.

Service Lubrication

Lubricating Hydraulic Selective Control Valve (SCV) Linkage

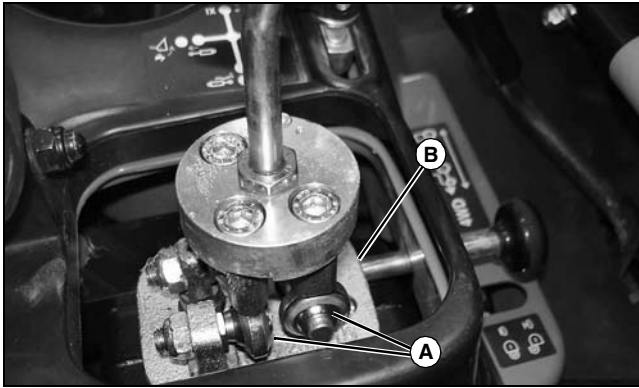

MX17437

Picture Note: Shown with rubber boot removed.

- Lubricate SCV ball joints (A) and SCV lock lever (B) with SUPER LUBE lubricant.

Lubricating 3-Point Hitch

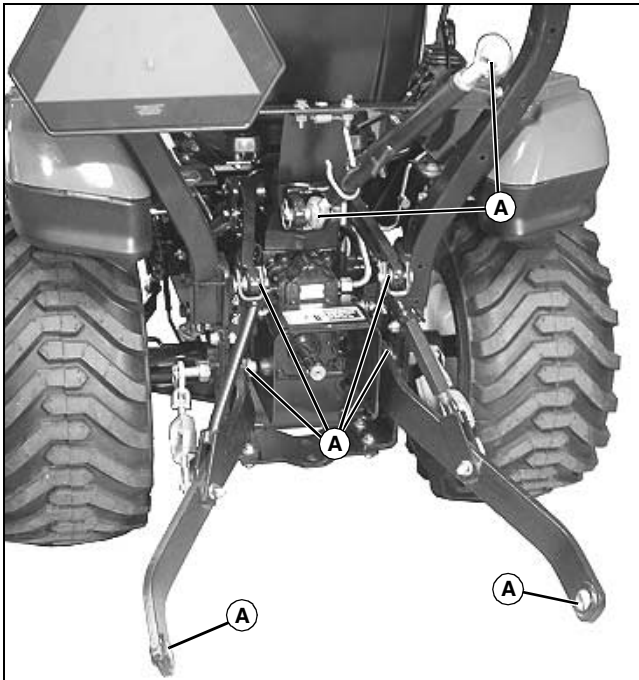

MX46356

- Lubricate ball joints (A) with SUPER LUBE lubricant.

Service Engine

Engine Warranty Maintenance Statement

Maintenance, repair, or replacement of the emission control devices and systems on this engine, which are being done at the customer's expense, may be performed by any non-road engine repair establishment or individual. Warranty repairs must be performed by an authorized John Deere dealer.

Avoid Fumes



CAUTION: Avoid injury! Engine exhaust fumes contain carbon monoxide and can cause serious illness or death.

- Move the machine to an outside area before running the engine.
- Do not run an engine in an enclosed area without adequate ventilation.
- Connect a pipe extension to the engine exhaust pipe to direct the exhaust fumes out of the area.
- Allow fresh outside air into the work area to clear the exhaust fumes out.

Engine Oil

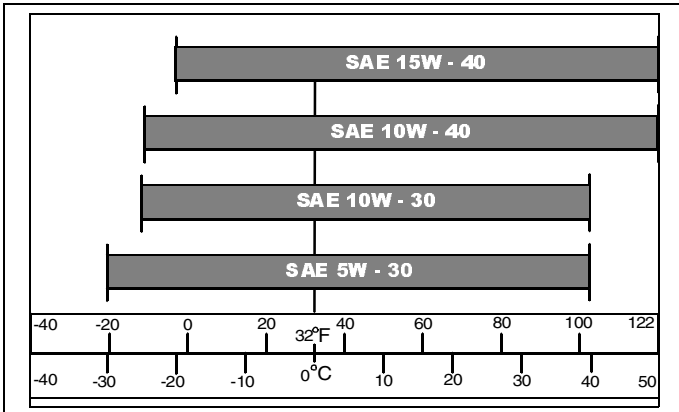

Use oil viscosity based on the expected air temperature range during the period between oil changes.

The following John Deere oils are preferred:

- PLUS-50™
- TORQ-GARD SUPREME™

Other oils may be used if above John Deere oils are not available, provided they meet the following specification:

- API Service Classification CH or higher
- ACEA Specification E3 or higher

Checking Engine Speeds

Check engine speeds when engine is warmed up and not under load.

Observe Tachometer.

Low idle (no load) 1575 rpm

High idle (no load) 3370 rpm

If above engine speeds are not to specifications, see your John Deere dealer.

Checking Engine Oil Level

IMPORTANT: Avoid damage! Failure to check the oil level regularly could lead to serious engine problems if oil level is low:

- Check oil level before operating.
- Check oil level when the engine is cold and not running.
- Keep level between the Full and the Add marks.
- Shut off engine before adding oil.

NOTE: Check oil twice a day if you run engine over 4 hours in a day.

Make sure engine is cold when checking engine oil level.

1. Park the machine safely. (See Parking Safely in the SAFETY section.)

Service Engine

IMPORTANT: Avoid damage! Dirt and contamination can enter engine when checking oil level. Clean area around dipstick before loosening or removing.

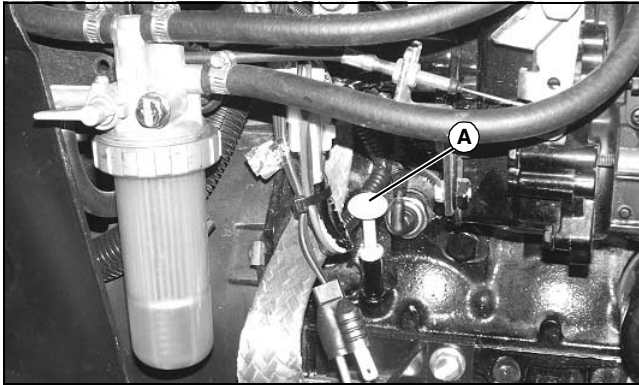

MX46343

Picture Note: 1023E shown. 1026R similar.

2. Remove dipstick (A), located at the right side of the engine. Wipe with a clean cloth.
3. Install dipstick.
4. Remove dipstick.

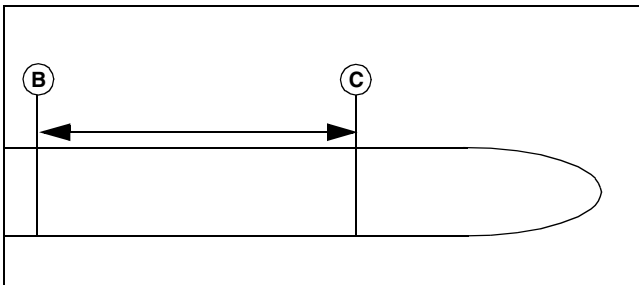

MIF

5. Check oil level on dipstick. Oil level should be between levels (B) and (C) on dipstick.
6. If oil level is low:
 - a. Raise hood.
 - b. Remove right side panel.

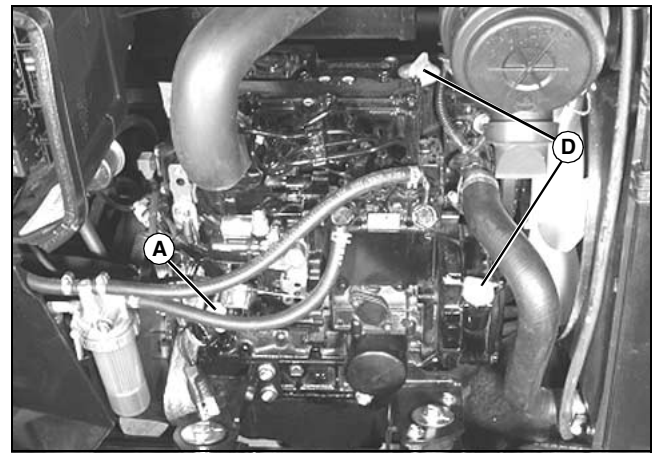

MX46361

Picture Note: 1023E shown. 1026R similar.

- c. Remove either oil fill cap (D).
- d. Add recommended engine oil until level is within operating range on dipstick. Do not overfill.
- e. Install dipstick.
7. If oil is above top hole mark on the dipstick, drain to proper level.
8. Install right side panel if removed.
9. Lower hood if opened.

Changing Engine Oil and Filter

IMPORTANT: Avoid damage! Change the oil more often if the vehicle is used in extreme conditions:

- **Extremely dusty conditions.**
- **Frequent slow or low-speed operation.**
- **Frequent short trips.**

1. Run engine to warm the oil.
2. Park machine safely. (See Parking Safely in the SAFETY section.)
3. Raise hood.
4. Remove right side panel.

Service Engine

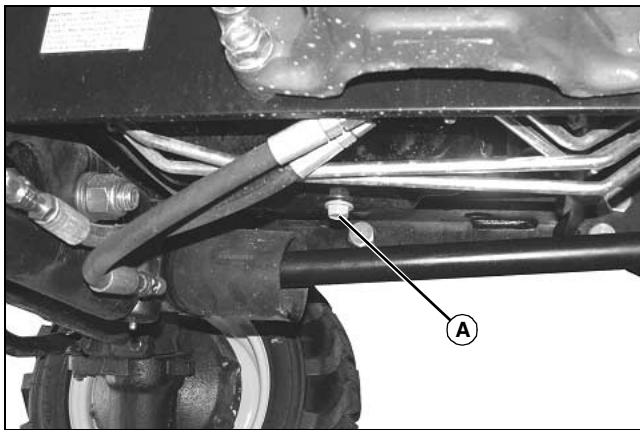

MX46341

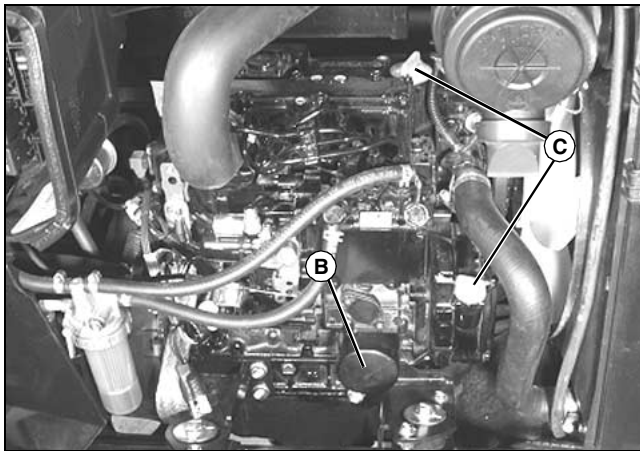

MX46361

Picture Note: 1023E shown. 1026R similar.

5. Place container under oil drain plug (A) located on under side of engine.
6. Remove drain plug.
7. Wipe dirt from around oil filter (B).
8. Turn filter counter-clockwise to remove.
9. Put a light coat of clean engine oil on the gasket of new filter.
10. Install replacement oil filter by turning filter clockwise until gasket contacts filter base. Tighten additional one half turn.
11. Install drain plug. Do not overtighten.
12. Remove either oil fill cap (C).
13. Add 2.7 L (2.9 qt) engine oil.
14. Install oil fill cap.
15. Start and run engine at idle to check for leaks.
16. Stop engine. Fix any leaks before operating.
17. Check engine oil level. Add oil if necessary.
18. Install right side panel.

19. Lower hood.

Cleaning Dust Unloading Valve

IMPORTANT: Avoid damage! Do not operate engine without air cleaner element and rubber dust unloading valve installed.

1. Park the vehicle safely. (See Parking Safely in the SAFETY section.)
2. Allow engine to cool.
3. Access the engine compartment.

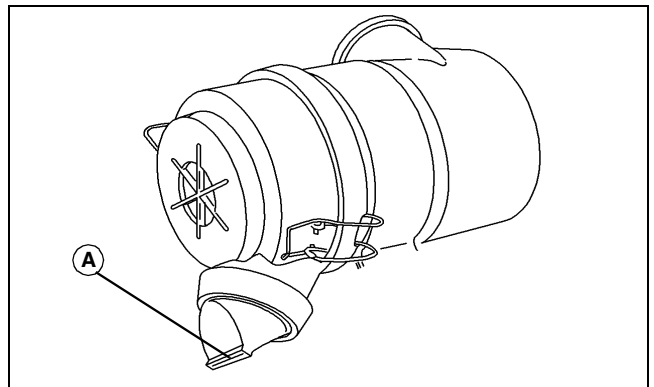

MX22502

4. Squeeze dust unloading valve (A) to clean. Remove and replace if damaged.

Checking Air Restriction Indicator (1026R only)

1. Park the machine safely. (See Parking Safely in the SAFETY section.)
2. Raise hood.

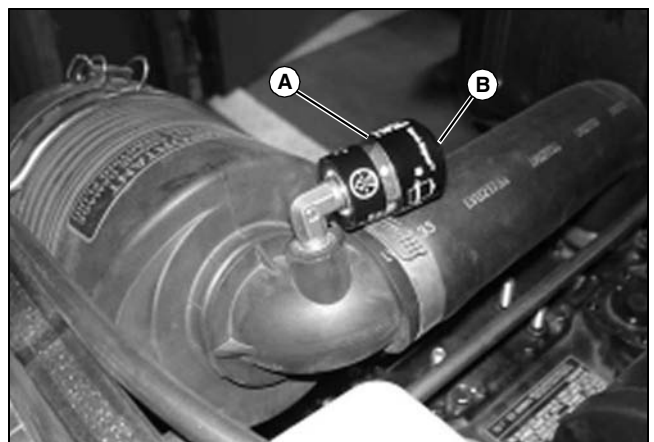

MX27907

3. Check the service window (A) on the indicator.

Service Engine

- Change the air filter if the service window is red.
 - Press the top of the indicator housing (B) to reset the indicator after service.
4. Lower hood.

Servicing Air Filter Elements



CAUTION: Avoid injury! Touching hot surfaces can burn skin. The engine, components, and fluids will be hot if the engine has been running. Allow the engine to cool before servicing or working near the engine and components.

IMPORTANT: Avoid damage! Dirt and debris can enter the engine through a damaged filter element:

- Do not wash paper element.
- Do not attempt to clean paper element by tapping against another object.
- Do not use pressurized air to clean element.
- Replace element only if it is very dirty, damaged or the seal is cracked.

Servicing Primary Air Filter Element:

1. Park machine safely. (See Park Safely in the SAFETY section.)
2. Allow engine to cool.
3. Raise hood.

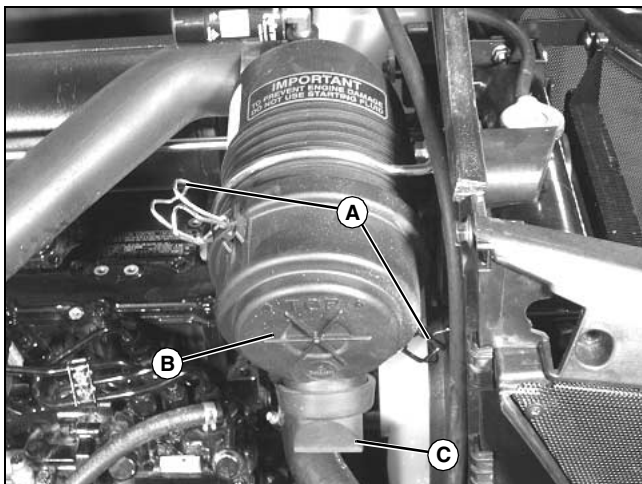

MX46299

4. Release latches (A) and remove cover (B).

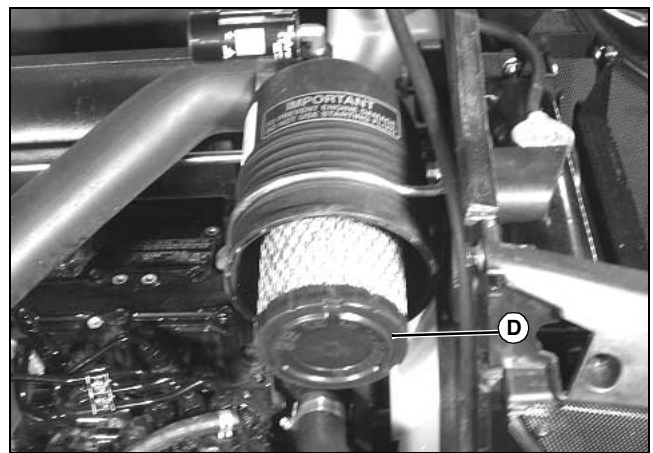

MX46300

5. Remove and discard primary element (D). Replace with a new primary filter element.
6. Install cover (B) with rubber dust unloading valve (C) pointing downward.
7. Hook latches (A) onto cover.
8. Lower hood.

Servicing Secondary Air Filter Element:

IMPORTANT: Avoid damage! Secondary element does not need routine replacement. Visually inspect it without removing from canister. Do not attempt to clean secondary element. If secondary element is replaced, install new primary and secondary element immediately to prevent dust from entering air intake system.

1. Remove cover.
2. Remove and discard primary air filter element.



MX46301

3. Remove and discard secondary air filter element (E). Replace with a new secondary air filter element.
4. Install new primary air filter element.
5. Install cover (B) with rubber dust unloading valve (C)

Service Engine

pointing downward.

6. Hook latches (A) onto cover.
7. Lower hood.

Checking Air Filter Intake Hoses and Clamps

1. Park machine safely. (See Parking Safely in the SAFETY section.)
2. Raise hood.

NOTE: Visually inspect hose for cracks and wear. Squeeze hose to check for deterioration. Hose should not be hard and brittle, nor soft or swollen.

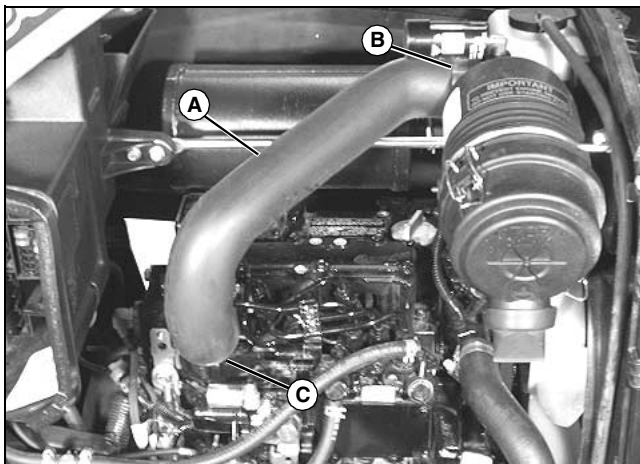

MX46293

3. Check air intake hose (A).
4. Tighten upper (B) and lower (C) clamps if necessary.
5. Lower hood.

Service Cooling System Safely

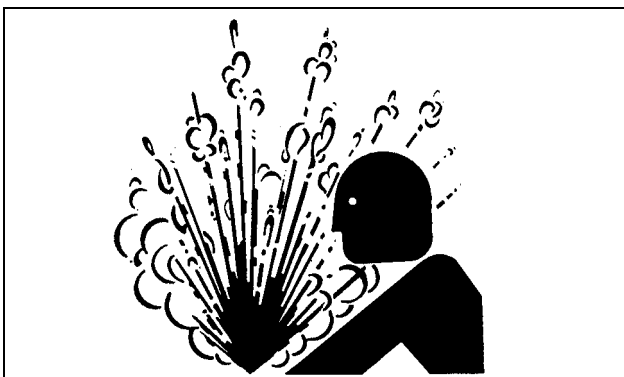

TS281



CAUTION: Avoid injury! The radiator will be hot and can burn skin. Built-up pressure may cause explosive release of coolant when the radiator cap is removed:

- Shut off the engine and allow to cool.
- Do not remove the cap unless the radiator and the engine are cool enough to touch with bare hands.
- Slowly loosen the cap to the first stop to release all pressure. Then remove the cap.

Recommended Engine Coolant

IMPORTANT: Avoid damage! Using incorrect coolant mixture can cause overheating and damage to the radiator and engine:

- Do not operate engine with plain water.
- Do not exceed a 50% mixture of coolant and water.
- Aluminum engine blocks and radiators require approved ethylene-glycol based coolant.

The engine cooling system is filled to provide year-round protection against corrosion and cylinder liner pitting, and winter freeze protection to -37 degrees C (-34 degrees F). If protection at lower temperatures is required, consult your John Deere dealer for recommendations.

The following coolants are preferred:

- John Deere COOL-GARD™ II Premix
- John Deere COOL-GARD™ Premix
- John Deere COOL-GARD™ PG Premix

John Deere COOL-GARD™ II Premix and John Deere COOL-GARD™ Premix are available in a concentration of 50% propylene glycol.

John Deere COOL-GARD™ PG Premix is available in a concentration of 55% propylene glycol.

Additional recommended coolants:

- John Deere COOL-GARD™ II Concentrate in a 40% to 60% mixture of concentrate with water.
- John Deere COOL-GARD™ Concentrate in a 40% to 60% mixture of concentrate with water.

If the recommended coolants are unavailable, use an ethylene glycol or propylene glycol base coolant that meets the following specification:

- ASTM D3306 prediluted (50%) coolant.

Service Engine

- ASTM D3306 coolant concentrate in a 40% to 60% mixture of concentrate with water.

Check container label before using to be sure it has the appropriate specifications for your machine. Use coolant with conditioner or add conditioner to coolant before using.

Water Quality

- Water quality is important to the performance of the cooling system. Distilled, deionized, or demineralized water is recommended with ethylene glycol base engine coolant concentrate.

Servicing Cooling System

Checking Cooling System

1. Park machine safely. (See Parking Safely in the SAFETY section.)
2. Allow engine to cool.
3. Raise hood.

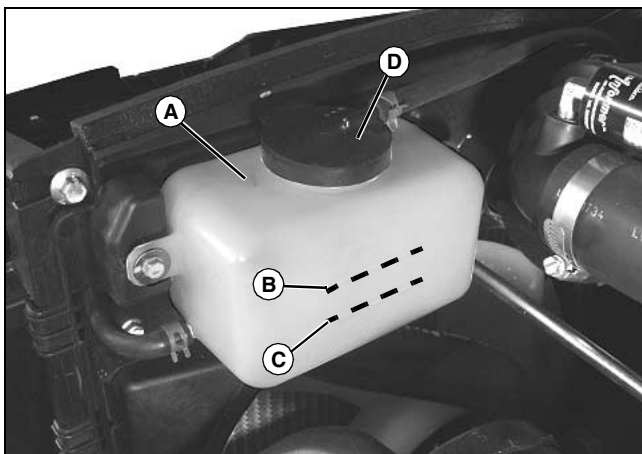

MX35598

4. Check recovery tank (A) coolant level:
 - If engine is warm, coolant level should be between the FULL line (B) and the LOW line (C).
 - If engine is cold, coolant level should be at the LOW line (C) on the recovery tank.
5. Remove recovery tank cap (D) if needed to add coolant.
6. Add recommended coolant.
7. Install recovery tank cap.
8. Lower hood.

Draining Cooling System

1. Park machine safely. (See Parking Safely in the SAFETY section.)
2. Allow engine to cool.

3. Raise hood.

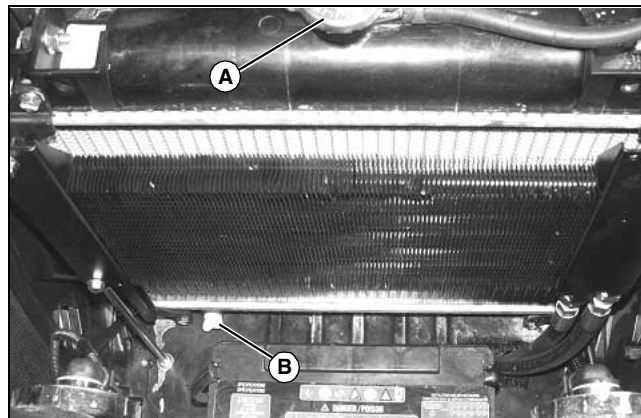

MX46344

4. Slowly open radiator cap (A) to the first stop to release all pressure.
5. Close radiator cap tightly.
6. Remove radiator screen, remove radiator drain plug (B) and drain coolant.



MX46343

Picture Note: 1023E shown. 1026R similar.

7. Remove engine block drain plug (C) and drain all coolant.
8. When coolant drains from the recovery tank, remove the radiator cap.
9. Install radiator and install engine block drain plugs.
10. Flush cooling system.

Flushing Cooling System

1. Fill cooling system with clean water and John Deere Cooling System Cleaner, or John Deere Cooling System Quick Flush or an equivalent. Follow directions on the container.
2. Install and tighten radiator cap.
3. Start and run engine until it reaches operating temperature.

Service Engine

4. Stop engine.
5. Remove radiator and engine block drain plugs.
6. Drain cooling system immediately before rust and dirt settle.
7. Install radiator and engine block drain plugs.

Filling Cooling System

IMPORTANT: Avoid damage! Using incorrect coolant mixture can damage the radiator:

- Do not operate engine with plain water.
- Do not exceed a 50% mixture of coolant and water.
- Aluminum engine blocks and radiators require approved ethylene-glycol based antifreeze.

NOTE: John Deere COOL-GARD coolant is recommended when adding new coolant to the cooling system.

Follow the directions on the container for correct mixture ratio.

1. Allow radiator to cool.
2. Fill cooling system.
 - Cooling system capacity is 3.7 L (3.9 qt).
3. Install and tighten radiator cap.
4. Run engine until it reaches operating temperature.
5. Stop engine.
6. Check recovery tank coolant level and add coolant if necessary
7. Lower hood.

Checking Radiator Hoses and Clamps

1. Park machine safely. (See Parking Safely in the SAFETY section.)
2. Raise hood.
3. Remove right side panel.

NOTE: Visually inspect hoses for cracks and wear. Squeeze hoses to check for deterioration. Hoses should not be hard and brittle, nor soft or swollen.

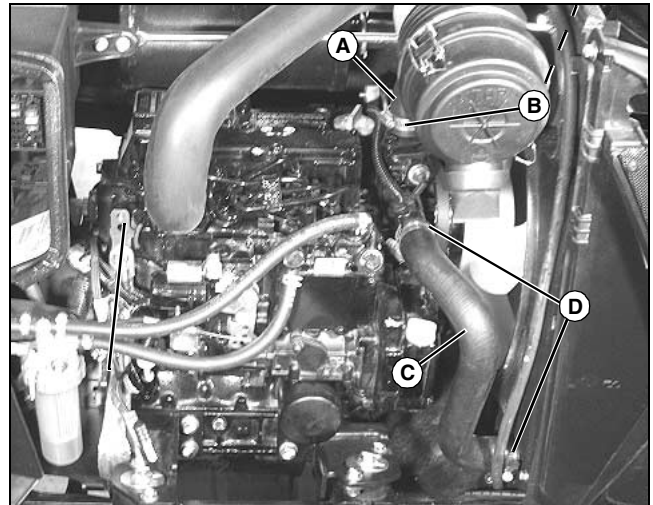

MX46302

4. Check upper radiator hose (A) for damage or cracking. Replace if necessary.
5. Check hose clamps (B) as needed.
6. Check lower radiator hose (C) for damage or cracking. Replace if necessary.
7. Check hose clamps (D) as needed.
8. Install right side panel.
9. Lower hood.

Cleaning Radiator Cooling Screen and Fins



CAUTION: Avoid injury! Compressed air can cause debris to fly a long distance.

- Clear work area of bystanders.
- Wear eye protection when using compressed air for cleaning purposes.
- Reduce compressed air pressure to 210 kPa (30 psi).

IMPORTANT: Avoid damage! The radiator cooling screen must be clean to prevent engine from overheating and to allow adequate air intake.

Service Engine

Cleaning Radiator Cooling Screen

IMPORTANT: Avoid damage! Reduced air intake can cause overheating. Keep radiator cooling fins clean.

Do not use pressure washers to clean radiator cooling fins. The force produced by pressure washers will damage the radiator and cooling fins.

Reduce compressed air pressure to 210 kPa (30 psi) when cleaning radiator and cooling fins. Spray compressed air straight into radiator. Do not spray radiator on an angle or cooling fins will be bent.

1. Park machine safely. (See Parking Safely in the SAFETY section.) Allow engine to cool.

2. Raise hood.

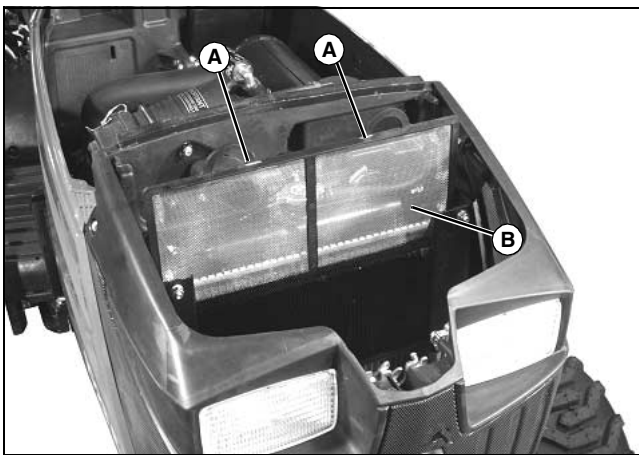

MX46303

Picture Note: Screen shown partially removed.

3. Lift tabs (A) to slide radiator screen (B) up out of retaining slot.

4. Clean screen with compressed air, brush or cloth.

5. Install screen in front of radiator.

6. Lower hood.

Cleaning Radiator Cooling Fins

IMPORTANT: Avoid damage! Reduced air intake can cause overheating. Keep radiator cooling fins clean.

Do not use pressure washers to clean radiator cooling fins. The force produced by pressure washers will damage the radiator and cooling fins.

Reduce compressed air pressure to 210 kPa (30 psi) when cleaning radiator and cooling fins. Spray compressed air straight into radiator. Do not spray radiator on an angle or cooling fins will be bent.

1. Park machine safely. (See Parking Safely in the SAFETY section.) Allow engine to cool.

2. Raise hood.

3. Remove radiator screen.

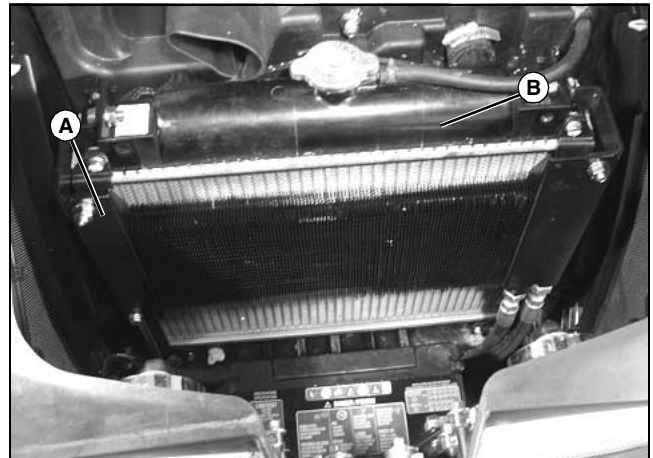

MX46304

4. Remove all dirt and debris from fins at front (A) and rear of radiator including fan shroud using compressed air or water.

5. Install radiator screen.

6. Lower hood.

Servicing the Alternator Belt



CAUTION: Avoid injury! Rotating parts can catch fingers, loose clothing, or long hair. Wait for engine and all moving parts to stop before leaving operator's station to adjust or service machine.

Checking Belt Tension

1. Park machine safely. (See Parking Safely in the SAFETY section.) Allow engine to cool.

2. Raise hood.

3. Remove left side panel.

Service Engine

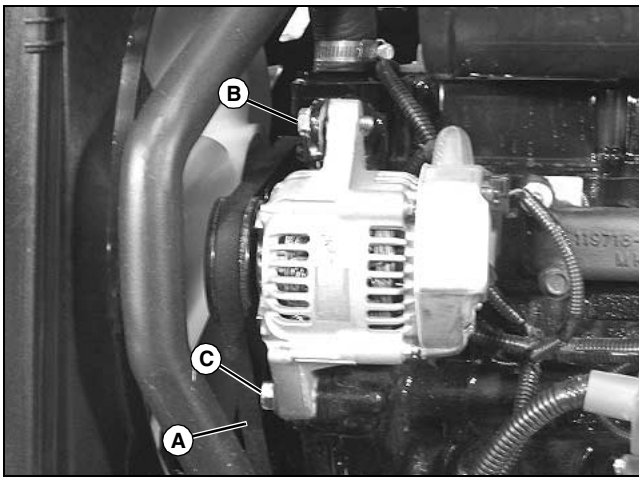

MX46305

4. Apply moderate thumb pressure to belt (A) halfway between the pulleys. Belt should deflect inward approximately 9 mm (3/8 in.).

5. Adjust belt tension if deflection is more or less than specified.

Adjusting Belt Tension

1. Loosen adjusting bolt (B) and pivot bolt (C).
2. Apply outward pressure to alternator housing until tension is correct.
3. Tighten bolts (B) and (C).
4. Check belt tension.
5. Install left side panel.
6. Lower hood.

Replacing Belt

NOTE: Replace alternator belt if excessive wear, damage or stretching is detected.

1. Park machine safely. (See Parking Safely in the SAFETY section.) Allow engine to cool.
2. Raise hood.
3. Remove left side panel.
4. Loosen adjusting bolt (B) and pivot bolt (C).
5. Apply inward pressure to alternator housing.
6. Remove belt from alternator sheave, fan sheave and crankshaft sheave.
7. Route belt over fan and remove.
8. Install new belt over fan and onto sheaves.
9. Apply outward pressure to alternator housing until tension is correct.
10. Tighten bolts (B) and (C).
11. Check belt tension. Adjust as necessary.

12. Install right side panel.
13. Lower hood.

Checking and Cleaning Fuel Filter Sediment Bowl and Replacing Filter



CAUTION: Avoid injury! Fuel vapors are explosive and flammable:

- Do not smoke while handling fuel.
- Keep fuel away from flames or sparks.
- Shut off engine before servicing.
- Cool engine before servicing.
- Work in a well-ventilated area.
- Clean up spilled fuel immediately.

NOTE: Change filter when fuel level is low.

Checking Sediment Bowl

1. Park machine safely. (See Parking Safely in the SAFETY section.) Allow engine to cool.
2. Check fuel sediment bowl. If water and deposits are detected, remove bowl and replace fuel filter.

Cleaning Sediment Bowl and Replacing Fuel Filter

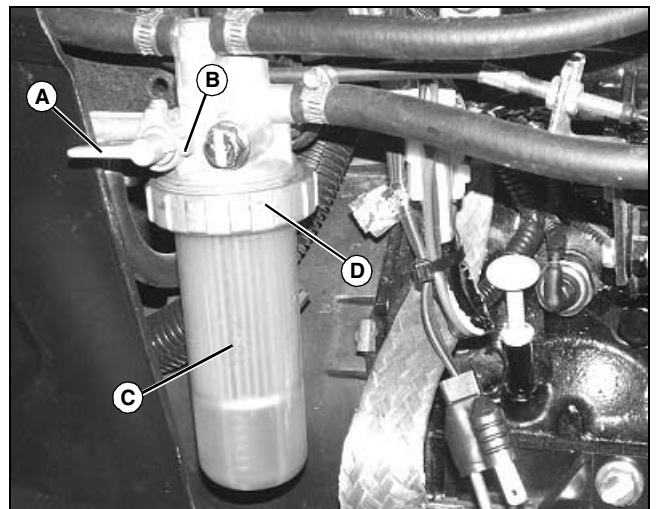

MX46343

1. Move the fuel shut-off valve (A) to the "C" (closed) position (B).
2. Position drain pan under fuel filter sediment bowl (C).
3. Turn locking collar (D) counterclockwise to remove bowl.
4. Remove and discard the fuel filter.
5. Clean bowl.

Service Engine

6. Install new filter to filter head.
7. Install sediment bowl and locking collar.
8. Open fuel shut-off valve.

NOTE: Fuel system is self bleeding.

9. Turn key to the ON position for 10-15 seconds before attempting to start, electric pump will purge air from sediment bowl.

Replacing Inline Fuel Filter

NOTE: Change filter when fuel level is low.



1. Inline fuel filter is located under left foot deck (A)
2. Position drain pan under fuel filter.

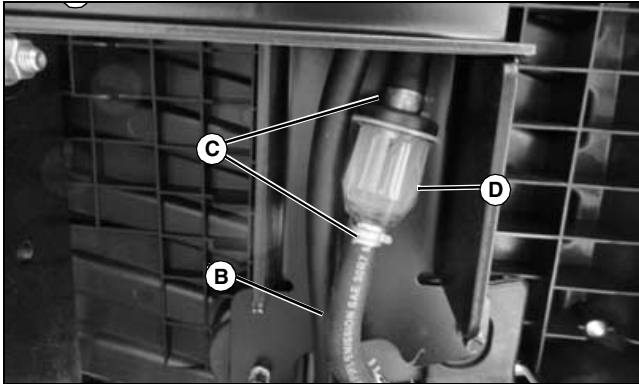

3. Clamp fuel line (B) between filter and tank to prevent fuel draining from fuel tank.
4. Remove two spring clamps (C).

NOTE: Flow direction arrow on filter body should point away from tank.

5. Remove old filter (D) and install new filter.
6. Replace two spring clamps.
7. Remove clamp used between filter and tank. Check for leaks.

Fuel Injection Pump

IMPORTANT: Avoid damage! Do not clean a warm or hot fuel injection pump with steam or water. Clean with compressed air if pump is not cooled.

NOTE: The fuel injection pump is calibrated by the engine manufacturer and should not require any adjustments.

If engine is hard to start, lacks power, or runs rough, see Troubleshooting Section of this manual.

After performing the check in the troubleshooting section and your engine is still not performing correctly, contact your John Deere dealer.

Fuel Injection Nozzles

IMPORTANT: Avoid damage! Do not service or remove fuel injection nozzles. Service life of injection nozzles may be shortened by overheating, improper operation, poor fuel quality, or excessive idling.

If injection nozzles are not working correctly or are dirty, engine will run poorly. See your John Deere dealer for service.

Cleaning Front Grille Screens

IMPORTANT: Avoid damage! Grille and side screens must be clean to prevent engine from overheating and to allow adequate air intake.

1. Check front grille screens for dirt, grass clippings and debris.
2. Raise hood and clean screens with a brush or cloth.
3. Lower hood.

Service Transmission

Transmission and Hydraulic Oil

IMPORTANT: Avoid damage! Transaxle is filled with John Deere HY-Gard™ (J20D) transmission oil at the factory. DO NOT mix oils.

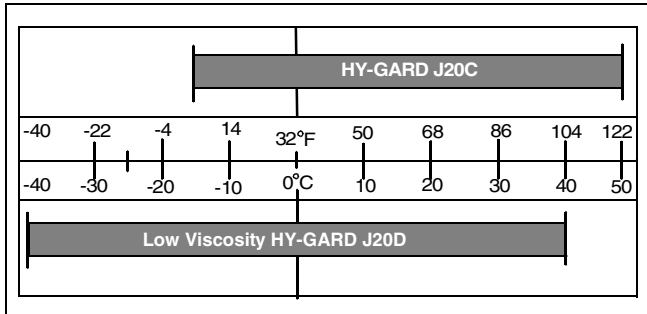

Do not use type “F” automatic transmission fluid.

Use Low Viscosity Hy-Gard™ (J20D) transmission oil.

John Deere Low Viscosity Hy-Gard transmission oil is specially formulated for operation below -18°C (0)°F to provide maximum protection for the hydraulic system.

Use oil viscosity based on the expected air temperature range during the period between oil changes.

IMPORTANT: Avoid damage! Use recommended oil only. Do not use engine oil or “Type F” automatic transmission fluid.

Other oils may be used if they meet John Deere standard JDM J20D or J20C.

Checking Front Axle Oil Level

IMPORTANT: Avoid damage! Allow oil one hour to settle before checking level to ensure accurate dipstick reading. Repeat oil level check after several hours of operation.

1. Park machine safely. (See Parking Safely in the SAFETY section.) Allow machine to cool down for at least one hour.

IMPORTANT: Avoid damage! Dirt and debris in oil may cause damage to the transaxle. Clean area around opening before removing dipstick.



MX46355

2. Loosen and remove dipstick (A) located on right side of front axle.
3. Wipe dipstick clean with a rag. Install dipstick but do not tighten. Allow dipstick to rest on top of threads.



MX46354

4. Remove dipstick. Oil level should be between high (B) and low (C) levels on dipstick. If oil level is low:
 - a. Add recommended oil through dipstick fill opening until oil level is correct.
 - b. Install and tighten dipstick.
5. Check front axle oil level again after the first several hours of operation.

Changing Front Axle Oil

1. Operate machine to warm front axle oil.
2. Park machine safely. (See Parking Safely in the SAFETY section.)

Service Transmission

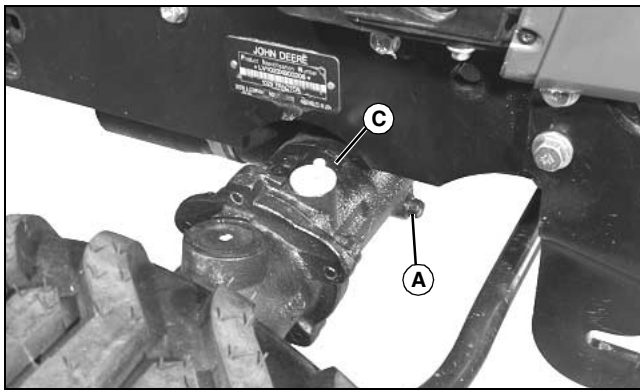

MX46355

3. Position drain pan under differential drain plug (A).

NOTE: For draining purposes, front axle contains approximately 2.8 L (3.0 qt) of oil.

4. Remove differential drain plug and allow oil to drain.

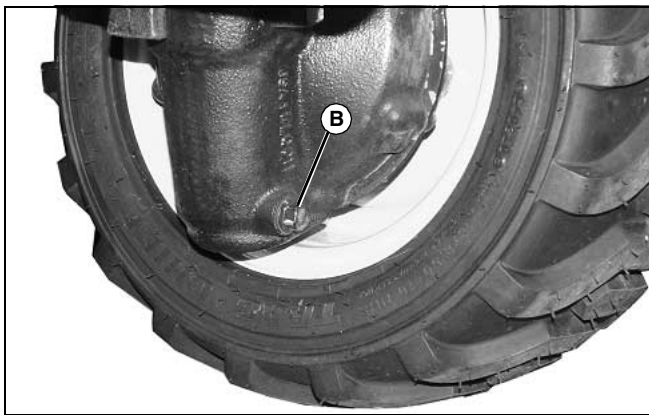

MX46351

5. Position drain pan under each front axle drain plug (B).

6. Remove both drain plugs and allow oil to drain.

7. Install and tighten both drain plugs after all oil has drained.

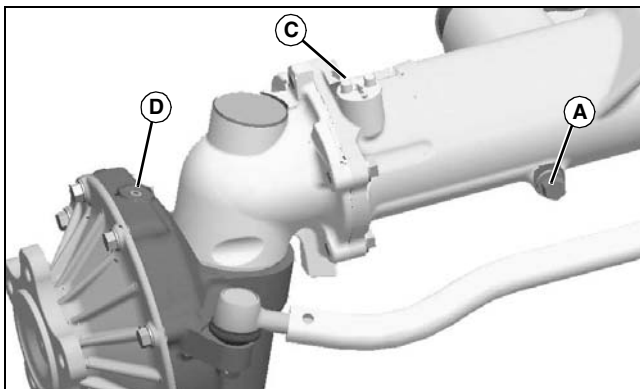

MX46355

8. Remove dipstick (C) located on right side of front axle and vent plug (D).

9. Add approximately 2.8 L (3.0 qt) of recommended oil

through dipstick fill opening until oil level is correct.

10. Install and tighten dipstick.

IMPORTANT: Avoid damage! Allow oil one hour to settle before checking level to ensure accurate dipstick reading. Repeat oil level check after several hours of operation.

11. Check front axle oil level.

Checking Transmission Oil Level

1. Park machine safely. (See Parking Safely in the SAFETY section.) Allow machine to cool down for at least one hour.

IMPORTANT: Avoid damage! Dirt and contamination can enter transmission when checking oil level. Clean area around dipstick before removing.

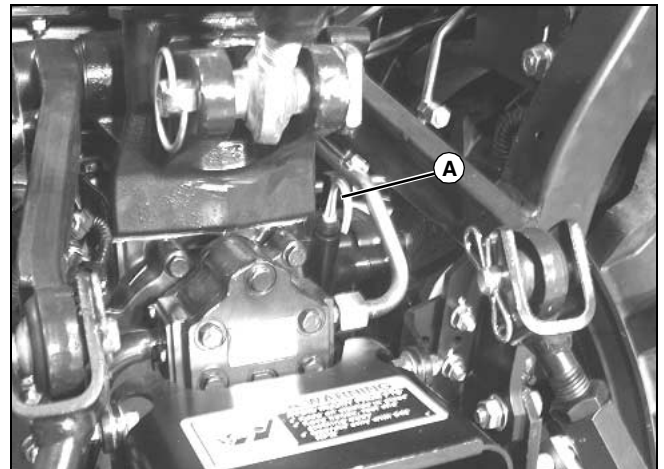

MX46339

2. Pull to remove dipstick (A), located at the right side of the transmission. Wipe with a clean cloth.

3. Install dipstick.

4. Remove dipstick.

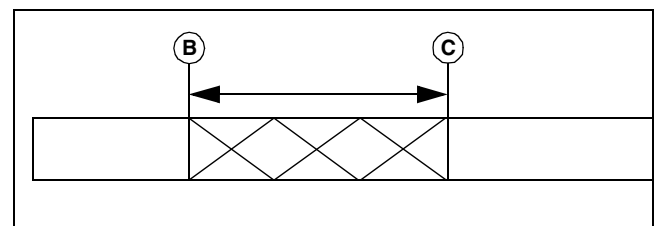

MIF

5. Check oil level on dipstick. Oil level should be between levels (B) and (C) on dipstick.

Service Transmission

IMPORTANT: Avoid damage! Help prevent dirt and other contaminants from entering the transmission. Clean area around fill cap before removing.

Do not overfill transmission. Oil expands during operation and could overflow.

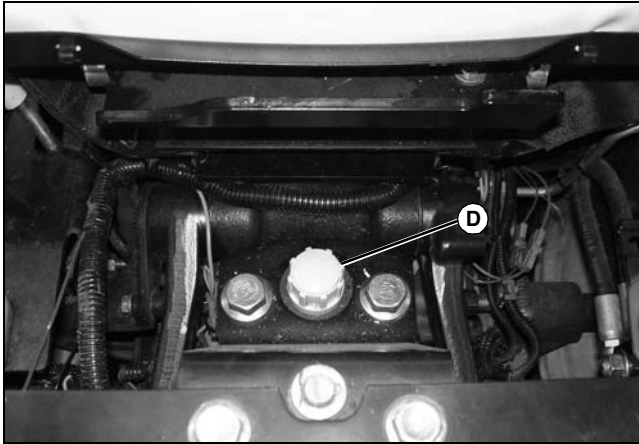

MX27911

6. If oil level is low:

- Remove filler cap (D).
- Add recommended oil through fill opening until oil level is correct.

7. If oil is above top mark on the dipstick, drain to proper level.

8. Install dipstick.

9. Install and tighten filler cap.

Changing Transmission Oil and Filter



CAUTION: Avoid injury! Touching hot surfaces can burn skin. The engine, components, and fluids will be hot if the engine has been running. Allow the engine to cool before servicing or working near the engine and components.

IMPORTANT: Avoid damage! Contamination of hydraulic fluid could cause transmission damage or failure. Do not remove cap from fill opening unless absolutely necessary.

Severe or unusual conditions may require a more frequent service interval.

1. Run engine a few minutes to warm the transmission oil.

2. Park machine safely. (See Parking Safely in the SAFETY section.)

NOTE: For draining purposes, the transmission contains approximately 12.3 L (13 qt) of oil.

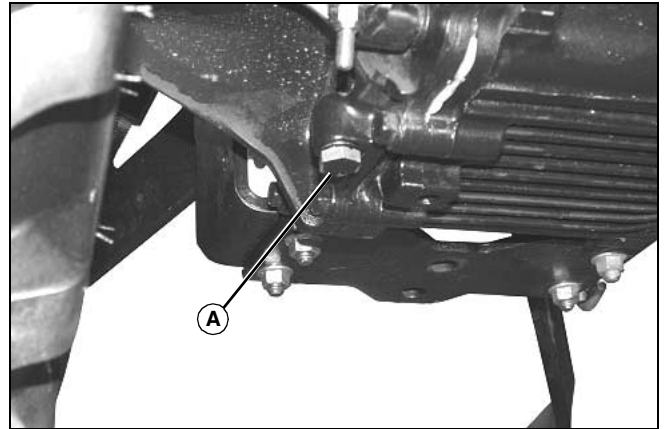

MX46352

3. Position drain pan under transmission drain plug (A). Remove plug and allow oil to drain completely.

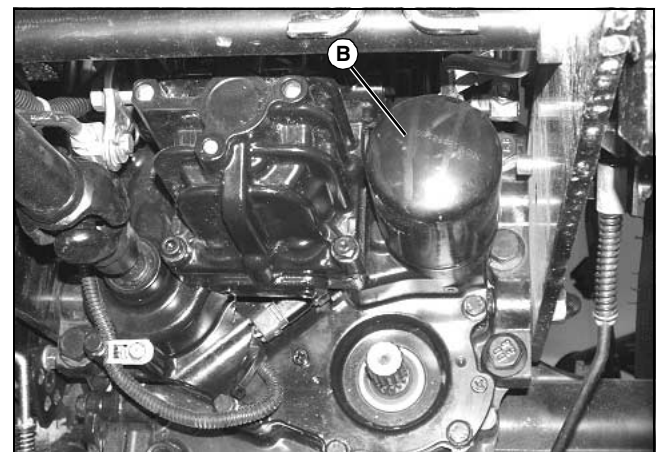

MX46353

4. Position drain pan under transaxle oil filter (B). Remove and discard filter. Allow residual oil to drain completely.

5. Put a film of clean transmission oil on seal of new filter.

6. Fill the filter 1/3 - 1/2 full of oil.

7. Install filter and turn clockwise until gasket makes contact with the mounting surface. Tighten 1/2 - 3/4 turn after gasket contact.

8. Install and tighten drain plug.

Service Transmission

IMPORTANT: Avoid damage! Help prevent dirt and other contaminants from entering the transmission. Clean area around fill cap before removing.

Do not overfill transmission. Oil expands during operation and could overflow.

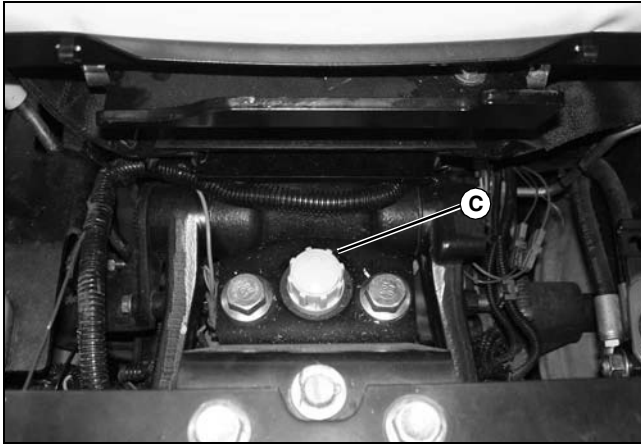

MX27911

9. Remove fill cap (C).
10. Add approximately 12.3 L (13 qt) of preferred transmission oil or equivalent into fill opening.
11. Install fill cap.
12. Start engine. Check for oil leaks.
13. Stop engine.
14. Check transmission oil level. Add oil if necessary.

Remove and Install Oil Suction Screen

1. Park the machine safely. (See Parking Safely in the SAFETY section.)



CAUTION: Avoid injury! The machine can fall or slip from an unsafe lifting device or supports.

- Use a safe lifting device rated for the load to be lifted.
- Lower machine onto jack stands or other stable supports and block wheels before servicing.

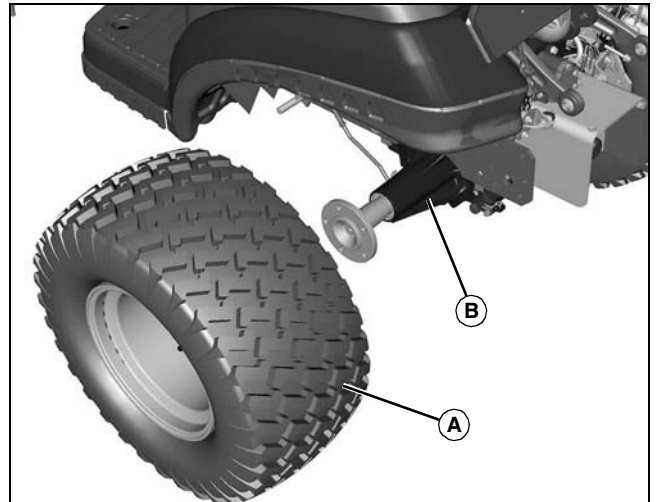

MX48828

2. Raise rear of machine, and remove left rear wheel (A).
3. Lower machine onto jack stand under left side of transmission (B).
4. Place a drain pan under left side of transmission.

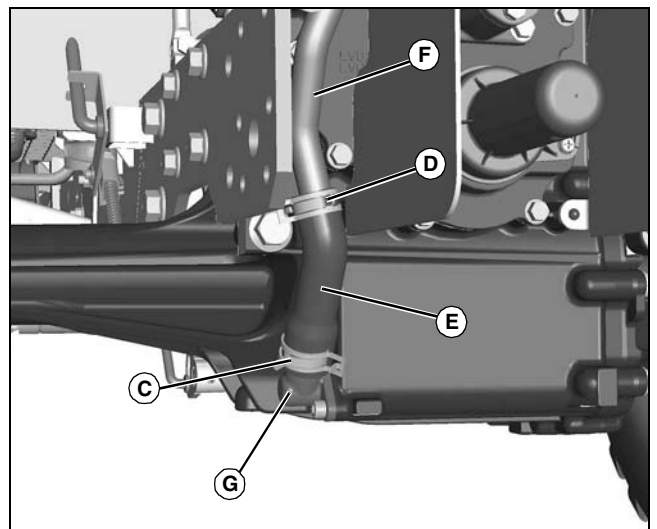

MX48829

5. Raise bottom hose clamp (C), and lower top hose clamp (D) onto hose (E).
6. Remove hose (E) from suction pipe (F) and lower manifold (G).

Service Transmission

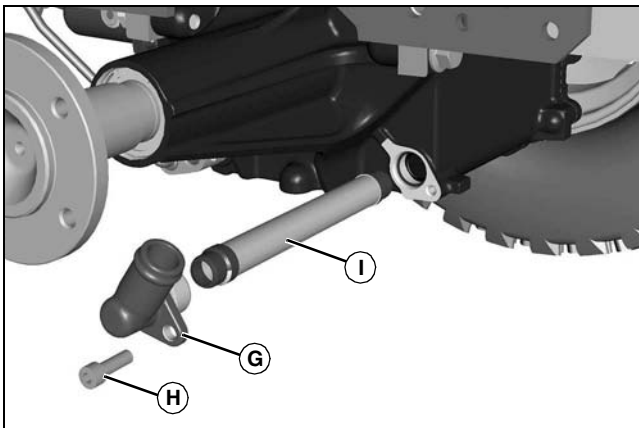

MX48830

7. Remove bolt (H).

NOTE: If suction screen does not come out with the lower manifold, reach in and remove screen from transmission. Be certain all O-Rings remain on assemblies.

8. Remove lower manifold (G) and suction screen (I).

NOTE: Depending upon your machine, you may have one or two magnets in screen.

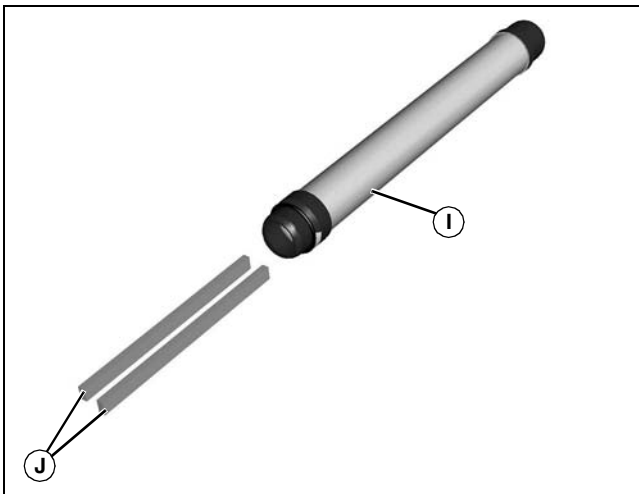

MX48831

9. Clean the suction screen (I). Remove the magnet(s) (J) from the screen. Clean magnet(s) and install into screen.

IMPORTANT: Avoid damage! Make sure that the free end of the suction screen is aligned and fitted to the socket in the transmission right side cover during assembly. Improper installation could result in crushing of the suction screen and subsequent hydraulic pump failure.

NOTE: Suction screen must remain perpendicular to lower manifold as shown below for it to align properly into flange area (K) on opposite side of transmission.

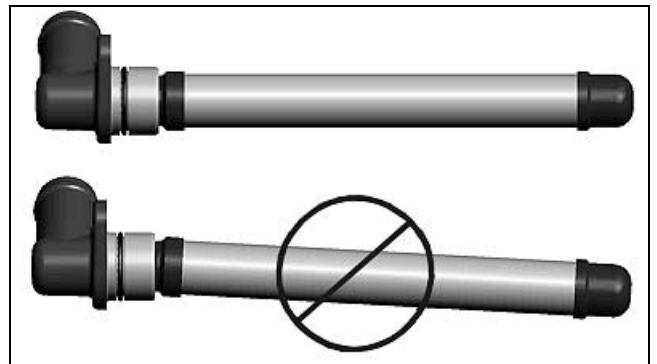

MX47490

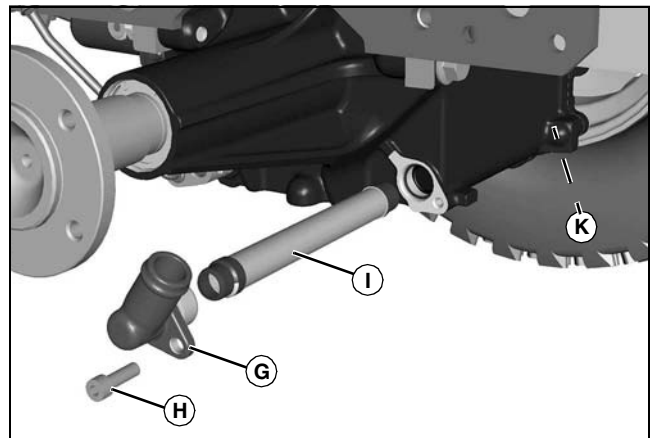

MX48830

10. Install suction screen (I) into lower manifold (G), and install assembly back into transmission housing opening.

11. Install bolt (H). Tighten bolt to 28 N•m (248 lb-in.).

Service Transmission

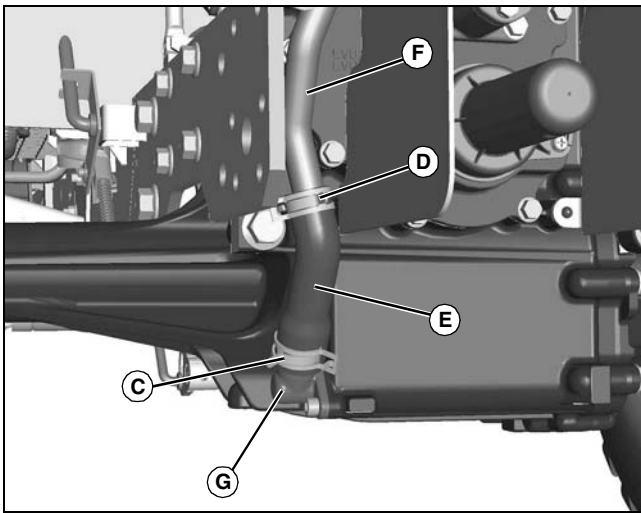

MX48829

12. Install hose (E) onto suction pipe (F) and lower manifold (G). Secure upper with upper clamp (D) and lower clamp (C).
13. Install left wheel onto machine. Tighten wheel bolts to 120 N•m (89 lb-ft).
14. Raise machine and remove jack stand. Lower machine.

Service Electrical

WARNING: Battery posts, terminals and related accessories contain lead and lead components, chemicals known to the State of California to cause cancer and reproductive harm. **Wash hands after handling.**

Service the Battery Safely

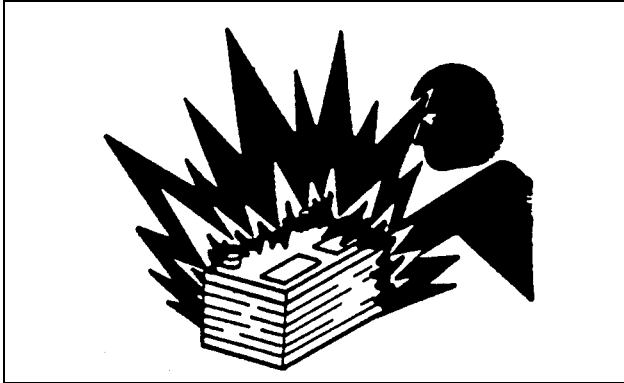

CAUTION: Avoid injury! Battery electrolyte contains sulfuric acid. It is poisonous and can cause serious burns:

- Wear eye protection and gloves.
- Keep skin protected.
- If electrolyte is swallowed, get medical attention immediately.
- If electrolyte is splashed into eyes, flush immediately with water for 15-30 minutes and get medical attention.
- If electrolyte is splashed onto skin, flush immediately with water and get medical attention if necessary.

The battery produces a flammable and explosive gas. The battery may explode:

- Do not smoke near battery.
- Wear eye protection and gloves.
- Do not allow direct metal contact across battery posts.
- Remove negative cable first when disconnecting.
- Install negative cable last when connecting.

Checking Battery Electrolyte Level

NOTE: Add only distilled water to replace battery electrolyte.

1. Park the machine safely. (See Parking Safely in the SAFETY section.)
2. Remove battery cell caps. Make sure cap vents are not plugged.

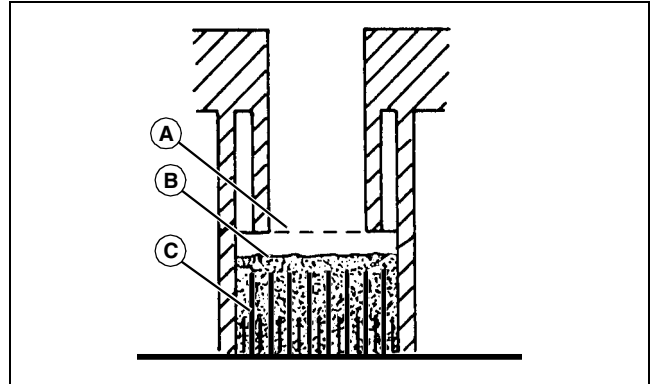

M39772

3. Check electrolyte level. Electrolyte (B) should be approximately halfway between bottom of filler neck (A) and top of plates (C).

IMPORTANT: Avoid damage! Do not overfill battery. Electrolyte can overflow when battery is charged and cause damage.

4. Add only distilled water if necessary.
5. Install battery cell caps.

Removing and Installing Battery

Removing:

1. Park machine safely. (See Park Safely in the SAFETY section.)

2. Raise hood.

NOTE: One headlight needs to be removed so there is clearance to remove the battery.

3. Remove two nuts (A) then remove headlight (B).

Service Electrical

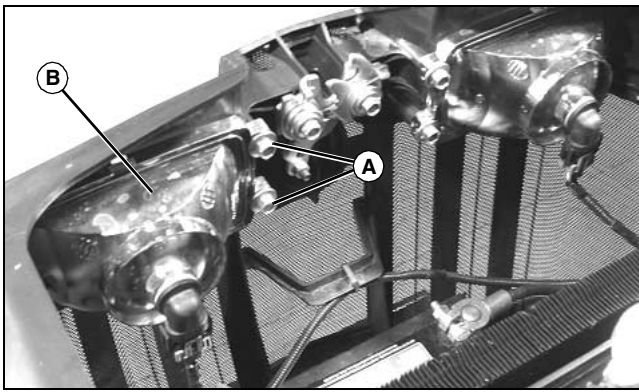

MX46338

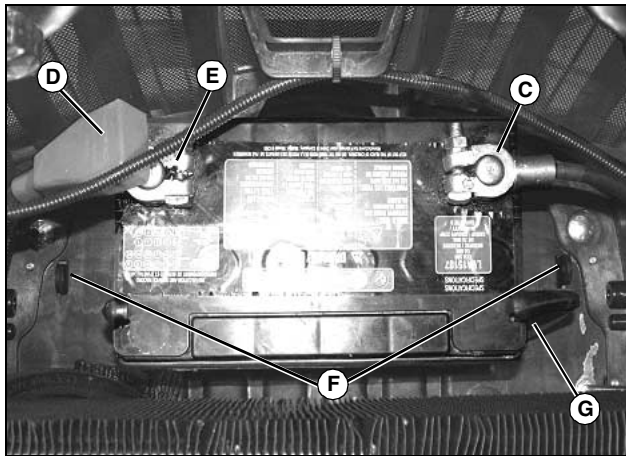

MX46337

Cleaning Battery and Terminals

1. Park machine safely. (See Parking Safely in the SAFETY section.)
2. Disconnect and remove battery.
3. Wash battery with solution of four tablespoons of baking soda to one gallon of water. Be careful not to get the soda solution into the cells.
4. Rinse the battery with plain water and dry.
5. Clean terminals and battery cable ends with wire brush until bright.
6. Install battery.
7. Attach cables to battery terminals, beginning with the positive cable, using washers and nuts.
8. Apply spray lubricant to terminal to prevent corrosion.

Using Booster Battery



CAUTION: Avoid injury! The battery produces a flammable and explosive gas. The battery may explode:

- Do not smoke or have open flame near battery.
- Wear eye protection and gloves.
- Do not jump start or charge a frozen battery. Warm battery to 16°C (60°F).
- Do not connect the negative (-) booster cable to the negative (-) terminal of the discharged battery. Connect at a good ground location away from the discharged battery.

4. Disconnect black negative (-) cable (C) from battery first.
5. Slide red positive terminal cover (D) back and disconnect red positive (+) cable (E).
6. Remove strap securing battery from both tabs (F) on battery tray.
7. Pull battery vent tube from battery tray.
8. Remove battery.

Installing:

1. Position battery in machine.
2. Route battery vent tube (G) through hole in battery tray.
3. Install strap securing battery to both tabs (F) on battery tray.
4. Connect positive (+) cable (E) to battery positive (+) terminal first, then negative (-) cable (C) to battery negative (-) terminal.
5. Apply spray lubricant on battery terminals to help prevent corrosion.
6. Position red positive battery terminal cover (D) on red positive (+) cable.
7. Install headlight using two nuts (A).
8. Lower hood.

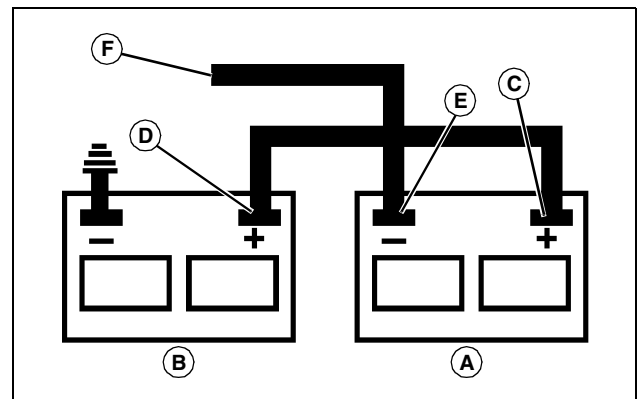

M71044

A - Booster Battery
B - Disabled Vehicle Battery

1. Connect positive (+) booster cable to booster battery (A)

Service Electrical

positive (+) post (C).

2. Connect the other end of positive (+) booster cable to the disabled vehicle battery (B) positive (+) post (D).

3. Connect negative (-) booster cable to booster battery negative (-) post (E).

IMPORTANT: Avoid damage! Electric charge from booster battery can damage machine components. Do not install negative booster cable to machine frame. Install only to the engine block.

Install negative booster cable away from moving parts in the engine compartment, such as belts and fan blades.

4. Connect the other end (F) of negative (-) booster cable to a metal part of the disabled machine engine block away from battery.

5. Start the engine of the disabled machine and run machine for several minutes.

6. Carefully disconnect the booster cables in the exact reverse order: negative cable first and then the positive cable.

Replacing Headlight Bulb

IMPORTANT: Avoid damage! Do not touch glass headlight bulb with bare skin or bulb may fail prematurely. Use gloves or a cloth when inspecting or replacing the bulb.

1. Park machine safely. (See Parking Safely in the SAFETY section.)

2. Raise hood.

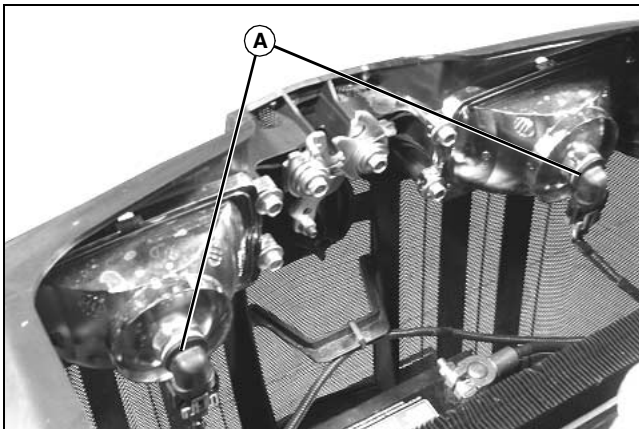

MX46338

3. Remove connector from base of bulb (A).

4. Rotate base counterclockwise to remove bulb assembly from housing.

5. Insert new bulb in housing and turn clockwise to secure.

6. Insert connector into base of bulb.

7. Lower hood.

8. Check operation of headlights.

Replacing Taillight Bulb

NOTE: Taillight can be serviced by removing the rear assembly lens only.

1. Park machine safely. (See Parking Safely in the SAFETY section.)

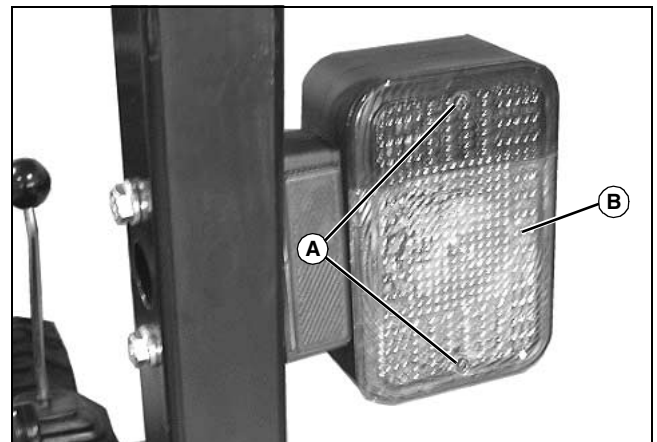

MX46297

2. Remove two screws (A) and lens (B) from the warning light/taillight assembly.

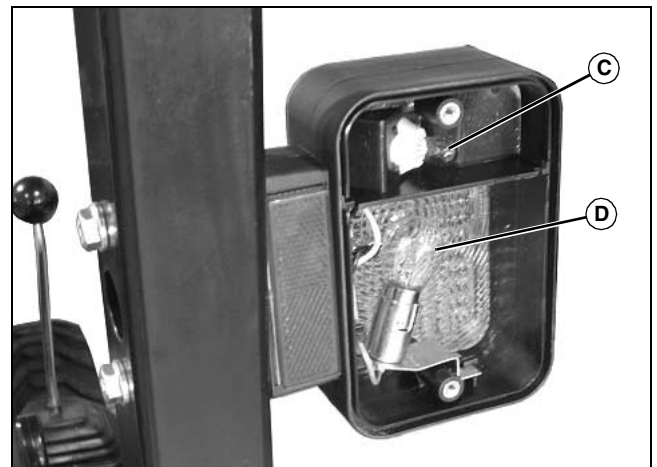

MX46298

3. Pull top bulb (C) to remove. Do not twist bulb. Push new bulb into socket.

4. Twist lower bulb (D) counter-clockwise and pull to remove. Push new bulb into socket and twist clockwise to secure.

5. Check operation of taillights.

Service Electrical

6. Install lens.

Replacing Worklight Bulb (1026R)

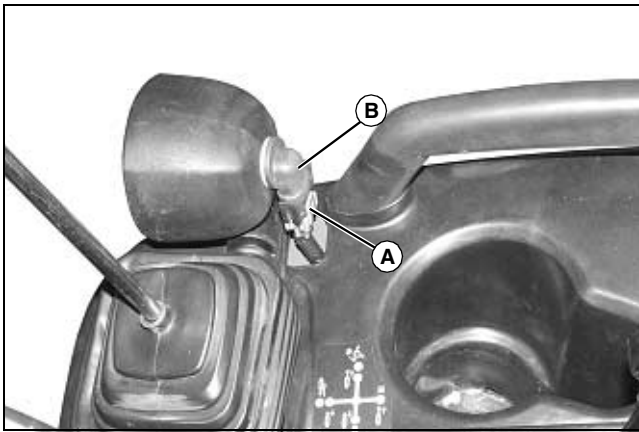

MX46342

1. Remove connector (A) from base of bulb.
2. Rotate base (B) counterclockwise to remove bulb assembly from housing.
3. Insert new bulb in housing and turn clockwise to secure.
4. Insert connector into base of bulb.
5. Check operation of worklights.

Replacing Relays and Fuses

IMPORTANT: Avoid damage! The electrical system may be damaged if incorrect replacement fuses are used. Replace the bad fuse with a fuse of the same amp rating.

1. Park machine safely. (See Parking Safely in the SAFETY section.)
2. Raise hood and remove right side panel.
3. Identify relay or fuse.

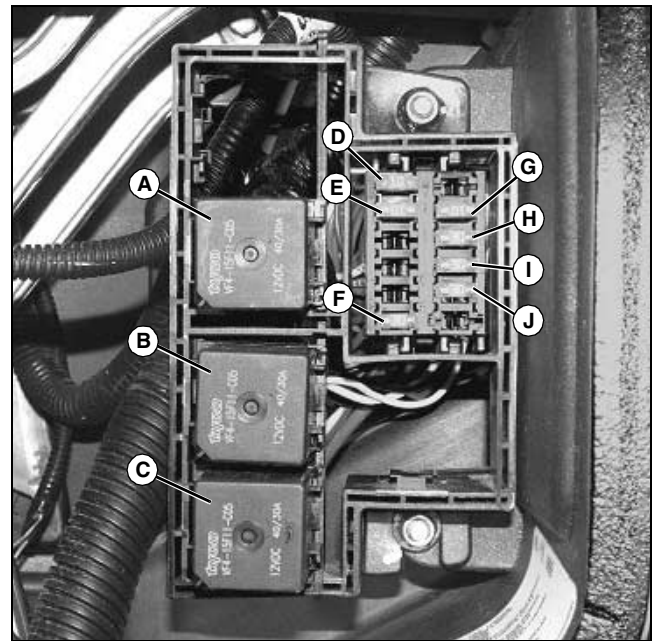

MX46357

Location	Circuit	Fuse Size
A	Relay - Glow Plug	N/A
B	Relay - Starter	N/A
C	Relay - Fuel Solenoid	N/A
D	Fuse - Taillights	10 amp
E	Fuse - Headlights	10 amp
F	Fuse - Fender Lights (1026R only) and Worklights (Option)	20 amp
G	Fuse - Ignition Run Power	10 amp
H	Fuse - Ignition Switch	20 amp
I	Fuse - Light Switch	30 amp
J	Fuse - Power Outlet (1026R Only)	15 amp

4. Pull defective relay or fuse from socket.
5. Push new relay or fuse or into socket.
6. Install right side panel and lower hood.

Service Steering & Brakes

Adjusting Brakes

1. Park machine safely. (See Parking Safely in the SAFETY section.)
2. Block front wheels securely, disengage MFWD and release park brake lock.



CAUTION: Avoid injury! The machine can fall or slip from an unsafe lifting device or supports.

- Use a safe lifting device rated for the load to be lifted.
- Lower machine onto jack stands or other stable supports and block wheels before servicing.

3. Raise rear of machine and support on jack stands. Remove right rear wheel.

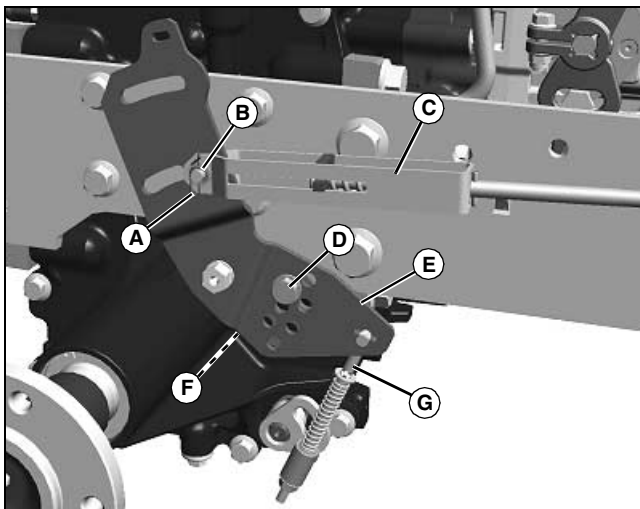

MX46789

Picture Note: Parts removed for better view.

4. Remove spring retainer (A), washer and pin (B) from brake rod yoke (C).
5. Remove bolt (D), two washers and nut connecting brake bellcrank (E) and transmission bellcrank (F) together.

NOTE: Keep both bellcranks together. Do not remove the differential lock rod assembly (G).

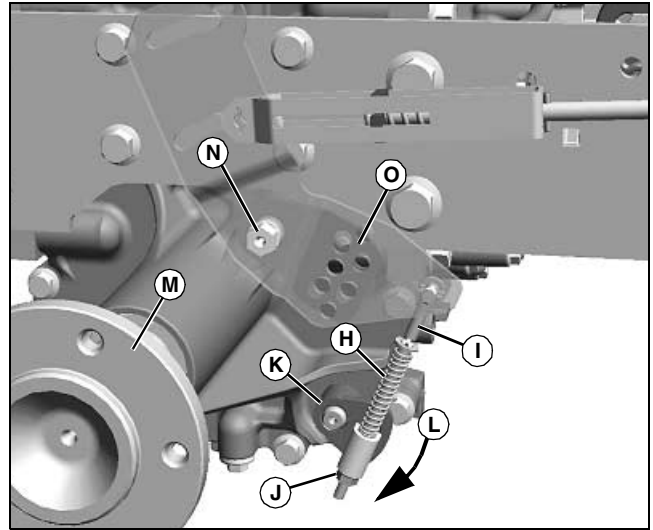

MX46790

6. Check the compressed length of the spring (H) on the differential lock rod (I). Adjust spring length to 65 mm (2.56 in.) with locknut (J) if required.

7. Rotate the differential lock bellcrank (K) clockwise (L) to fully engage the differential lock.

NOTE: Turn the wheel hub (M) while rotating the bellcrank to ensure complete engagement. Depress and hold the differential lock control to maintain the engagement.

8. With the differential lock fully engaged, use a 17 mm socket on the transmission brake input shaft (N) to apply and hold 5-15 N•m (44-133 lb-in) of torque.

9. Locate the set of holes (O) with the best alignment in the brake and transmission bellcranks. Install the original hardware and tighten to 50 N•m (37 lb-ft).

10. Rotate the wheel hub to release the differential lock control and allow the differential lock bellcrank (K) to return to its original counter-clockwise disengaged position.

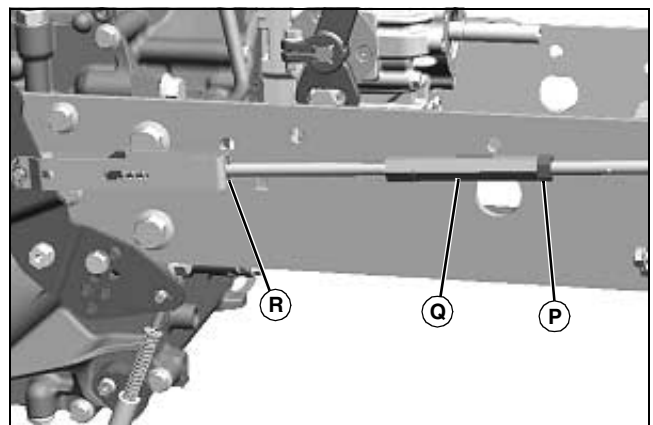

MX46791

11. Loosen the brake rod turnbuckle locknut (P). Turn the

Service Steering & Brakes

turnbuckle (Q) several turns to increase the length of the brake rod.

12. Align the brake rod yoke (C) with the single hole on the transmission bellcrank (E) and secure with the original pin, washer and spring retainer. The slotted hole in the bellcrank is only used for European models.

NOTE: When a wheel hub is slowly rotated and the differential lock is operated, a clicking sound will be heard or felt in the hub when the differential components begin to engage or disengage. The absence of this sound ensures the differential is completely engaged or disengaged.

13. Turn the turnbuckle (Q) as required to shorten the brake rod until the differential lock components just begin to engage and a clicking is heard (or felt in the hub) as the hub is rotated.

14. Turn the turnbuckle in the opposite direction just until the clicking is no longer heard (or felt in the hub) as the hub is rotated. Tighten the turnbuckle locknut (P) securely.

15. Rotate the hub to ensure it turns freely, without brake drag or partial differential lock engagement.

- If brake drag is noted, repeat steps 4 through 14.
- If partial differential lock engagement is noted, repeat steps 10 through 14.

16. Lock the park brake. The brake rod spring must not be completely compressed. It should be partially compressed and a gap of 4-7 mm (0.16-0.28 in.) exist between the brake rod yoke and the roll pin (R). If the gap is not to specification, repeat steps 4 through 15.

17. Install rear wheel and tighten lug bolts to 120 N•m (89 lb-ft).

18. Lower machine and check operation of brakes and differential lock.

Service Miscellaneous

Using Proper Fuel (Diesel)

Use the proper diesel fuel to help prevent decreased engine performance and increased exhaust emissions. Failure to follow the fuel requirements listed below can void your engine warranty.

Consult your local fuel distributor for properties of the diesel fuel in your area.

In general, diesel fuels are blended to satisfy the low temperature requirements of the geographical area in which they are marketed.

Diesel fuels specified to EN 590 or ASTM D975 are recommended.

Required fuel properties

In all cases, the fuel shall meet the following properties:

Cetane number of 45 minimum. Cetane number greater than 50 is preferred, especially when temperatures are below -20°C (-4°F) or elevations above 1500 m (5000 ft).

Cold Filter Plugging Point (CFPP) should be at least 5°C (9°F) below the expected lowest temperature or **Cloud Point** below the lowest ambient temperature.

Fuel lubricity should pass a maximum scar diameter of 0.45 mm as measured by ASTM D6079 or ISO 12156-1.

IMPORTANT: Avoid damage! Improper fuel additive usage may cause damage on fuel injection equipment of diesel engines.

If a fuel of low or unknown lubricity is used, addition of John Deere PREMIUM DIESEL FUEL CONDITIONER at the specified concentration is recommended.

Sulfur content

- Diesel fuel quality and fuel sulfur content must comply with all existing emissions regulations for the area in which the engine operates.
- Use only ultra low sulfur diesel (ULSD) fuel with a maximum of 0.0015% (15mg/kg) sulfur content.

IMPORTANT: Avoid damage! Do not mix diesel engine oil or any other type of lubricating oil with diesel fuel.

Using Bio-Diesel Fuel

Bio-diesel fuels may be used only if the bio-diesel fuel properties meet the latest edition of ASTM D6751, ASTM D7467, EN14214, or equivalent specification.

The current maximum allowable bio-diesel concentration is a 5% blend (also known as B5) in petroleum diesel fuel.

Concentrations up to B20 may be used if machine is modified with genuine John Deere B20 kit. Use of B6-B20

fuel will require maintenance interval changes from some components, and special procedures for fuel handling and machine storage.

To learn of any changes to the recommendations for bio-diesel usage with your diesel engine, ask your John Deere dealer or reference the Services and Support link on the John Deere Commercial and Consumer Equipment website.

Handling and Storing Diesel Fuel



CAUTION: Avoid injury! Handle fuel carefully. Do not fill the fuel tank when engine is running. Do not smoke while you fill the fuel tank or service the fuel system.

IMPORTANT: Avoid damage! Do not use galvanized containers—diesel fuel stored in galvanized containers reacts with zinc coating in the container to form zinc flakes. If fuel contains water, a zinc gel will also form. The gel and flakes will quickly plug fuel filters and damage fuel injectors and fuel pumps.

- Fill the fuel tank at the end of each day's operation to prevent water condensation and freezing during cold weather.
- When fuel is stored for an extended period or if there is a slow turnover of fuel, add a fuel conditioner to stabilize the fuel and to prevent water condensation. Contact your fuel supplier for recommendations.

Filling Fuel Tank



CAUTION: Avoid injury! Fuel vapors are explosive and flammable:

- Shut engine off before filling fuel tank.
- Allow engine to cool before refueling.
- Do not smoke while handling fuel.
- Keep fuel away from flames or sparks.
- Fill fuel tank outdoors or in well ventilated area.
- Clean up spilled fuel immediately.
- Use clean approved non-metal container to prevent static electric discharge.

Service Miscellaneous

IMPORTANT: Avoid damage! Dirt and water in fuel can cause engine damage:

- Clean dirt and debris from the fuel tank opening.
- Use clean, fresh, stabilized fuel.
- Fill the fuel tank at the end of each day's operation to keep condensation out of the fuel tank.
- Use a non-metallic funnel with a plastic mesh strainer when filling the fuel tank or container.

Fill fuel tank at the end of each day's operation to prevent condensation and freezing during cold weather.

1. Park machine safely. (See Parking Safely in the SAFETY section.)
2. Allow engine to cool.
3. Remove any trash from area around fuel tank cap.
4. Remove fuel tank cap slowly to allow any pressure built up in tank to escape.
5. Fill fuel tank only to bottom of filler neck. Do not overfill.
6. Install fuel tank cap.
 - Gas models: Turn cap until clicks.

Raising and Lowering Hood

Raising

1. Park machine safely. (See Parking Safely in the SAFETY section.)

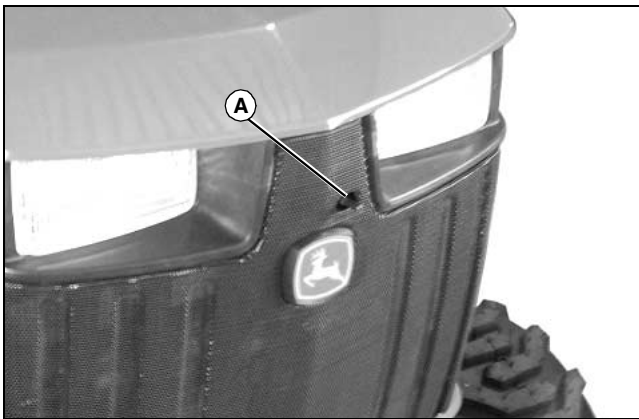

MX46307

2. Push release lever (A) sideways to open hood.

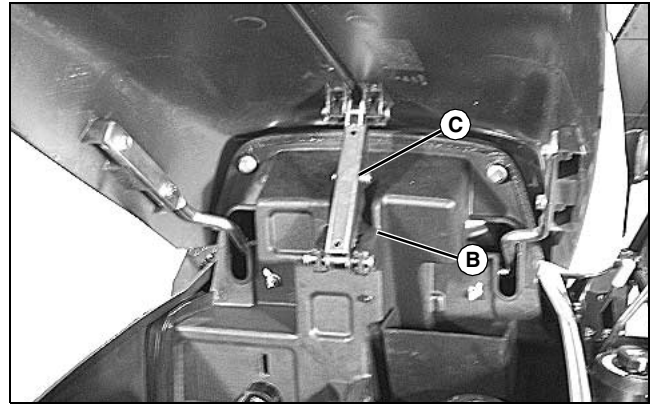

MX46335

3. Raise hood until latch support bracket engages.

Lowering

1. Lift hood slightly to remove weight on latch support bracket.
2. Pull center of support bracket (C) toward the front of the machine to release and slowly lower hood.
3. Gently push down on both sides of front of hood to lock latch.

Removing and Installing Side Panels

Removing

1. Park machine safely. (See Parking Safely in the SAFETY section.)
2. Raise hood.

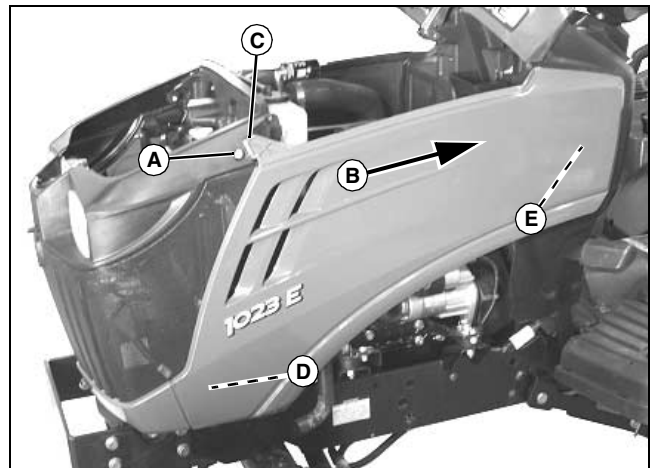

MX46336

Picture Note: Left side shown. Right side is the same.

3. Remove bolt (A) and nut, retaining the side panel to machine.
4. Slide the side panel toward the rear (B) until the top (C),

Service Miscellaneous

front (D) and rear (E) tabs clear their mounting slots in the machine. Remove the side panel.

Installing

1. Align the panel mounting tabs with the mating slots in the machine.
2. Slide the panel forward, install bolt (A) and nut to secure side panel.
3. Lower the hood.

Checking Wheel Bolts and Hardware



CAUTION: Avoid injury! Check rim, hub, and axle hardware periodically to prevent possible machine roll-over.

When machine is new or anytime wheel hardware is loosened, tighten all bolts after one hour of operation and every four hours thereafter until proper torque values are maintained.

Tightness of wheel hardware must be maintained according to service interval recommendations. Check wheel bolt tightness and torque as follows:

Front Wheel Bolts

Tighten front wheel bolts alternately to 120 N•m (89 lb-ft).

Rear Wheel Bolts

Tighten rear wheel bolts alternately to 120 N•m (89 lb-ft).

Removing and Installing Wheels



CAUTION: Avoid injury! Remove wheels safely.

- Use a safe lifting device and support machine securely on jack stands.
- Block front and rear of wheel not raised to prevent machine movement.
- Wheel can be heavy or difficult to handle when removing.

Front Wheel Removal

1. Loosen wheel bolts slightly before raising front axle.
2. Raise front of machine and lower onto support stands so that machine is supported by front axle.
3. Remove five wheel bolts and wheel.

NOTE: If the front wheels are being removed to perform

work on the front axles, lower machine onto suitable stands that will support the machine by the frame.

Front Wheel Installation

1. Install wheels onto axle, insert wheel bolts and lightly tighten bolts.
2. Raise front of machine, remove support stands and lower machine to floor.
3. Tighten wheel bolts to 120 N•m (89 lb-ft).

Rear Wheel Removal

1. Loosen wheel bolts slightly before raising machine rear axle.
2. Raise rear of machine and lower onto support stands so that machine is supported by rear axle.
3. Remove five wheel bolts and wheel.

Rear Wheel Installation:

1. Install wheels onto axle, insert wheel bolts and lightly tighten bolts.
2. Raise rear of machine, remove support stands and lower machine to floor.
3. Tighten wheel bolts to 120 N•m (89 lb-ft).

Checking Tire Pressure



CAUTION: Avoid injury! Explosive separation of tire and rim parts is possible when they are serviced incorrectly:

- Do not attempt to mount a tire without the proper equipment and experience to perform the job.
- Do not inflate the tires above the recommended pressure.
- Do not weld or heat a wheel and tire assembly. Heat can cause an increase in air pressure resulting in an explosion. Welding can structurally weaken or deform the wheel.
- Do not stand in front or over the tire assembly when inflating. Use a clip-on chuck and extension hose long enough to allow you to stand to one side.

1. Check tires for damage.
2. See tire pressures in SPECIFICATIONS.
3. Check tire pressure with an accurate gauge.
4. Add or remove air, if necessary

Service Miscellaneous

Selecting Front Tire Rolling Direction



CAUTION: Avoid injury! Remove wheels safely.

- Use a safe lifting device and support machine securely on jack stands.
- Block front and rear of wheel not raised to prevent machine movement.
- Wheel can be heavy or difficult to handle when removing.

Machines equipped with directional type tires (such as bar tires) have directional arrows located on the tire sidewall. Under most conditions, tires should be installed with the directional arrow pointing in the direction of travel.

If machine is mainly used for loader operations, lug direction may be reversed to increase tire life and improve traction while backing out of dirt piles.

Move wheel from one side of machine to the other to change tire rolling direction.

Cleaning Plastic Surfaces

IMPORTANT: Avoid damage! Improper care of machine plastic surfaces can damage that surface:

- Do not wipe plastic surfaces when they are dry. Dry wiping will result in minor surface scratches.
- Use a soft, clean cloth (bath towel, diaper, automotive mitt).
- Do not use abrasive materials, such as polishing compounds, on plastic surfaces.

1. Rinse hood and entire machine with clean water to remove dirt and dust that may scratch the surface.
2. Wash surface with clean water and a mild liquid automotive washing soap.
3. Dry thoroughly to avoid water spots.
4. Wax the surface with a liquid automotive wax. Use products that specifically say "contains no abrasives."

IMPORTANT: Avoid damage! Do not use a power buffer to remove wax.

5. Buff applied wax by hand using a clean, soft cloth.

Cleaning and Repairing Metal Surfaces

Cleaning:

Follow automotive practices to care for your vehicle painted metal surfaces. Use a high-quality automotive wax regularly to maintain the factory look of your vehicle's painted surfaces.

Repairing Minor Scratches (surface scratch):

1. Clean area to be repaired thoroughly.

IMPORTANT: Avoid damage! Do not use rubbing compound on painted surfaces.

2. Use automotive polishing compound to remove surface scratches.
3. Apply wax to entire surface.

Repairing Deep Scratches (bare metal or primer showing):

1. Clean area to be repaired with rubbing alcohol or mineral spirits.
2. Use paint stick with factory-matched colors available from your authorized dealer to fill scratches. Follow directions included on paint stick for use and for drying.
3. Smooth out surface using an automotive polishing compound. Do not use power buffer.
4. Apply wax to surface.

Troubleshooting

Using Troubleshooting Chart

If you are experiencing a problem that is not listed in this chart, see your John Deere distributor for service.

When you have checked all the possible causes listed and you are still experiencing the problem, see your John Deere distributor.

Engine

If	Check
Engine Will Not Start Or Is Hard To Start	2-speed range lever not in proper position. PTO engaged. Engine throttle lever not pushed forward. Fuel shut-off valve CLOSED (OFF). Stale fuel / improper fuel / fuel level. Wrong engine oil viscosity. Cold start system not being used, or malfunctioning. Plugged fuel filter. Plugged air intake filter. Dirty or faulty fuel injectors. Blown fuse. Failed fuel solenoid. Other electrical problem.
Engine Runs Rough Or Stalls	Fuel shut-off valve partially closed. Plugged fuel filter. Plugged air intake system. Fuel cap vent dirty. Faulty seat switch. Stale or improper fuel / fuel level. Dirty or faulty fuel injectors. Low coolant temperature. See your John Deere Dealer. Fuel pump not functioning properly. See your John Deere Dealer.

Troubleshooting

If	Check
Engine Overheats	<p>Dirty grille, radiator screen, or radiator cooling fins.</p> <p>Plugged air intake filter.</p> <p>Low coolant level.</p> <p>Cooling system needs flushing.</p> <p>Defective radiator cap.</p> <p>Defective thermostat.</p> <p>Defective water temperature indicator or sender.</p> <p>Low oil level.</p> <p>Loose or defective alternator belt.</p> <p>Engine speed too low for load. Do not operate at low idle.</p> <p>Operating at too fast ground speed for conditions.</p>
Engine Knocks	<p>Engine oil level low.</p> <p>Injection pump out of time. See your John Deere Dealer.</p> <p>Low coolant temperature. See your John Deere Dealer.</p> <p>Engine overheating.</p> <p>Idle speed too low.</p>
Engine Lacks Power	<p>Improper type of fuel.</p> <p>Plugged air intake system.</p> <p>Plugged fuel filter.</p> <p>Engine Overheating. Operating at too fast ground speed for conditions.</p> <p>Engine oil viscosity too high.</p> <p>Low coolant temperature. See your John Deere Dealer.</p> <p>Improper valve clearance. See your John Deere Dealer.</p> <p>Dirty or faulty fuel injectors. See your John Deere Dealer.</p> <p>Injection pump out of time. See your John Deere Dealer.</p> <p>Implement improperly adjusted, causing drag on machine. See implement operator's manual.</p> <p>Rate-of-drop valve closed, causing hydraulic load on engine.</p>
Low Oil Pressure	<p>Engine oil level low.</p> <p>Plugged oil filter.</p> <p>Improper type of oil.</p> <p>Oil leaks.</p>
Engine Uses Too Much Oil	<p>Find and correct oil leaks.</p> <p>Incorrect engine oil.</p> <p>Plugged air intake filter.</p>

Troubleshooting

If	Check
Engine Emits White Smoke	<p>Improper type of fuel.</p> <p>Low engine temperature.</p> <p>Defective thermostat. See your John Deere Dealer.</p> <p>Engine out of time. See your John Deere Dealer.</p>
Engine Emits Black or Gray Exhaust Smoke	<p>Improper type of fuel.</p> <p>Plugged air intake system.</p> <p>Operating at too fast ground speed for conditions.</p> <p>Dirty or faulty fuel injectors. See your John Deere Dealer.</p> <p>Engine out of time. See your John Deere Dealer.</p>
High Fuel Consumption	<p>Improper type of fuel.</p> <p>Plugged air intake system.</p> <p>Operating at too fast ground speed for conditions.</p> <p>Improper valve clearance. See your John Deere Dealer.</p> <p>Dirty or faulty fuel injectors. See your John Deere Dealer.</p> <p>Engine out of time. See your John Deere Dealer.</p> <p>Implement improperly adjusted, causing drag on machine. See implement operator's manual.</p> <p>Low engine temperature.</p> <p>Restricted air intake system.</p> <p>Plugged crankcase vent tube or baffle.</p> <p>Brakes dragging.</p>

Electrical System

If	Check
Battery Will Not Charge	<p>Loose or corroded connections.</p> <p>Defective battery - check electrolyte level (if applicable).</p> <p>Dead cell in battery.</p> <p>Loose or defective alternator belt.</p> <p>Defective alternator.</p>
Battery Discharge Indicator Stays On With Engine Running	<p>Low engine speed.</p> <p>Defective battery.</p> <p>Defective alternator.</p> <p>Loose or defective alternator belt.</p>

Troubleshooting

If	Check
Starter Will Not Work	<p>Loose or corroded battery connections.</p> <p>Blown fuse.</p> <p>Low battery output - check electrolyte level (if applicable).</p> <p>Neutral start switch faulty or not adjusted properly - See your John Deere Dealer.</p> <p>Key switch or starter faulty - See your John Deere Dealer.</p> <p>Range transmission lever not in neutral position.</p> <p>PTO engaged.</p>
Starter Turns Slowly	<p>Low battery output - check electrolyte level (if applicable).</p> <p>Low battery power - charge battery.</p> <p>Engine oil viscosity too heavy.</p> <p>Loose or corroded battery connections.</p>
One Light Circuit Not Working	Fuse blown.

Machine

If	Check
Excessive Machine Vibration	<p>Engine speed too slow.</p> <p>Drive shaft universal joint bearings worn.</p> <p>Throttle linkage out of adjustment.</p>
Machine Will Not Move With Engine Running	<p>Park brake locked.</p> <p>Transmission oil level low.</p> <p>Transmission oil cold - allow engine to warm.</p> <p>Range shift lever in "N" (neutral) position.</p>
PTO shuts off	<p>Push PTO switch down to shut off switch. Lock the park brake, shut off engine and allow engine to cool. Check coolant level. If low, check for leaks. Fix leak issue and add coolant as necessary. Clean debris away from radiator cooling fins.</p> <p>Once coolant level has been verified, leaks have been repaired and debris has been cleaned sit on seat and start engine. If the coolant temperature light is still illuminated, then the tractor still needs to cool further before the PTO will be operational. Run the tractor at low idle to allow the cooling fan to cool the engine. With the PTO switch still off, the light will turn off once the tractor has cooled. After the light turns off, pull PTO switch out to on position. If PTO still does not work, see your John Deere Dealer for service.</p>
3-point Hitch Fails To Lift	<p>Low hydraulic oil level.</p> <p>Rate-of-drop valve closed.</p> <p>Excessive load on hitch.</p> <p>Hydraulic oil too cold.</p>

Troubleshooting

If	Check
3-point Hitch Drops Slowly Or Does Not Drop	Rate-of-drop valve closed. Rate-of-drop valve set too slowly.
3-point Hitch Drops Too Fast	Rate-of-drop valve set too fast. Load too heavy.

Brakes

If	Check
Rear Wheel Brakes Not Working	Brakes out of adjustment. Worn or damaged brake linkage. See your John Deere Dealer.

Steering

If	Check
Steering Not Working	Improper tire inflation. Low hydraulic fluid levels. Steering linkage needs lubrication. Excessive play in steering. See your John Deere Dealer.

Storage

Storing Safety



CAUTION: Avoid injury! Fuel vapors are explosive and flammable. Engine exhaust fumes contain carbon monoxide and can cause serious illness or death:

- Run the engine only long enough to move the machine to or from storage.
- Do not store vehicle with fuel in the tank inside a building where fumes may reach an open flame or spark.
- Allow the engine to cool before storing the machine in any enclosure.

IMPORTANT: Avoid damage! Stale fuel can produce varnish and plug carburetor or injector components and affect engine performance.

- Add fuel conditioner or stabilizer to fresh fuel before filling tank.

4. Mix fresh fuel and fuel stabilizer in separate container. Follow stabilizer instructions for mixing.
5. Fill fuel tank with stabilized fuel.
6. Run engine for a few minutes to allow fuel mixture to circulate through fuel system.

Engine:

Engine storage procedure should be used when vehicle is not to be used for longer than 60 days.

1. Change engine oil and filter while engine is warm.
2. Service air filter if necessary.
3. Clean debris from engine air intake screen.
4. Clean the engine and engine compartment.
5. Remove battery.
6. Clean the battery and battery posts. Check the electrolyte level on batteries requiring maintenance.
7. Close fuel shut-off valve, if your machine is equipped.
8. Store the battery in a cool, dry place where it will not freeze.

NOTE: The stored battery should be recharged every 90 days.

9. Charge the battery.
10. Store the vehicle in a dry, protected place. If vehicle is stored outside, put a waterproof cover over it.

Preparing Machine for Storage

1. Repair any worn or damaged parts. Replace parts if necessary. Tighten loose hardware.
2. Repair scratched or chipped metal surfaces to prevent rust.
3. Wash the machine and apply wax to metal and plastic surfaces.
4. Run machine for five minutes to dry belts and pulleys.
5. Apply light coat of engine oil to pivot and wear points to prevent rust.
6. Lubricate grease points.
7. Check tire pressure.

Preparing Fuel and Engine For Storage

Fuel:

If you have been using Stabilized Fuel, add stabilized fuel to tank until the tank is full.

NOTE: Filling the fuel tank reduces the amount of air in the fuel tank and helps reduce deterioration of fuel.

If you are not using Stabilized Fuel:

1. Park machine safely in a well-ventilated area.

NOTE: Try to anticipate the last time the machine will be used for the season so very little fuel is left in the fuel tank.

2. Turn on engine and allow to run until it runs out of fuel.
3. Turn key to OFF position.

Removing Machine From Storage

1. Check tire pressure.
2. Check engine oil level.
3. Check battery electrolyte level. Charge battery if necessary.
4. Install battery.
5. Lubricate all grease points.
6. Open fuel shut-off valve, if your machine is equipped.
7. Run the engine 5 minutes without any attachments running to allow oil to be distributed throughout engine.
8. Be sure all shields and guards or deflectors are in place.

Specifications

Engine

Model 1023E

Manufacturer	Yanmar
Model Number	3TNM72
Type	Diesel
Engine Power ¹ at 3200 engine rpm	16.5 kW (22.4 hp ²)
PTO Horsepower	11.4 kW (15.3 hp)
Cylinders	Three
Rated Engine Speed	3200 rpm
Operating Range	1575 - 3370 rpm
Cooling Type	Liquid
Oil Filter	Standard Single Element
Air Cleaner	Dry Type, Two Stage

Model 1026R

Manufacturer	Yanmar
Model Number	3TNV76
Type	Diesel
Engine Power ¹ at 3200 engine rpm	18.5 kW (25.2 hp ²)
PTO Horsepower	13.4 kW (18.0 hp)
Cylinders	Three
Rated Engine Speed	3200 rpm
Operating Range	1575 - 3370 rpm
Cooling Type	Liquid
Oil Filter	Standard Single Element
Air Cleaner	Dry Type, Two Stage

Drivetrain

Type	2 Range Hydrostatic
Number of Speeds	Infinite
Mechanical Front Wheel Drive (MFWD)	Standard
MFWD Capability	All Ranges
MFWD Engagement	On The Go
Final Drive	Spur Gear
Rear Axle Capacity (Continuous)	715 kg (1576 lb)
Front Axle Capacity (Continuous)	612 kg (1349 lb)

1. According to SAE J1995.

2. PS - German Term for horse power in which one PS is equivalent to .9863 horse power.

Specifications

Electrical System

Type	12 Volt
Battery Size	500 Cold Cranking Amps @ -18°C (0°F)
Alternator	40 amp

Front Wheels and Tires

Standard	18x8.5-10 R4
Optional	18x8.5-10 R3

Rear Wheels and Tires

Standard	26x12.00-12 R4
Optional	26x12.00-12 R3

Front Tire Inflation Pressures (Maximum)

18x8.5-10 R4	152 kPa (22 psi)
18x8.5-10 R3	152 kPa (22 psi)

Rear Tire Inflation Pressures (Maximum)

26x12.00-12 R4	138 kPa (20 psi)
26x12.00-12 R3	138 kPa (20 psi)

Fluid Capacities

Fuel Tank	21.2 L (5.6 gal)
Cooling System	3.7 L (3.9 qt)
Crankcase with Filter	2.7 L (2.9 qt)
Transmission and Hydraulic System	12.3 L (13 qt)
Front Axle	2.8 L (3.0 qt)

Ground Speeds

NOTE: All ground speed calculations shown are with machine equipped with standard 26x12.00-12 R4 rear tires and operated at 3200 engine rpm.

Forward and Reverse - Range High0-14.6 km/h (0-9.1 mph)
Forward and Reverse - Range Low0-6.6 km/h (0-4.1 mph)

Dimensions

Specifications

NOTE: Machine equipped with standard 26x12.00-12 R4 rear tires and 18x8.5-10 R4 front tires.

Wheelbase	1450 mm (57.1 in.)
Overall Length with 3-point Hitch	2605 mm (102.6 in.)
Overall Width	1202 mm (47.3 in.)
Tread Width	
Front	918 mm (36.1 in.)
Rear	895 mm (35.2 in.)
Height From Ground	
To Top of Hood (R3 Tires)	1061 mm (42 in.)
To Top of ROPS	2190 mm (86.2 in.)
Ground Clearance	
Front Axle	195 mm (7.7 in.)
Turning Radius	
MFWD Off	2256 mm (88.8 in.)

Weight

Machine equipped with a ROPS, 3-point hitch, standard R4 tires and all fluids

1023E	610 kg (1345 lb)
1026R	655 kg (1444 lb)

3-Point Hitch

Type	Limited Category 1
Lift Capacity-61 cm (24 in.) behind link arms	309 kg (681 lb)
Lift Capacity-at link ends	650 kg (1433 lb)

Torque Values - Inch Fastener Hardware

Torque Values (Dry)							Torque Values (Lubricated)						
Size	Grade 2 ¹		Grade 5		Grade 8		Size	Grade 2 ²		Grade 5		Grade 8	
	N•m	lb-ft	N•m	lb-ft	N•m	lb-ft		N•m	lb-ft	N•m	lb-ft	N•m	lb-ft
1/4	7.4	5.5	12	9	17	12.5	1/4	6.1	4.5	9.5	7	13.6	10
5/16	15	11	24	18	35	26	5/16	12.2	9	20	15	28	21
3/8	27	20	45	33	62	46	3/8	22	16	35	26	49	36
7/16	43	32	70	52	102	75	7/16	35	26	56	41	79	58
1/2	68	50	108	80	156	115	1/2	53	39	85	63	122	90

Specifications

Torque Values (Dry)							Torque Values (Lubricated)						
Size	Grade 2 ¹		Grade 5		Grade 8		Size	Grade 2 ²		Grade 5		Grade 8	
9/16	95	70	156	115	217	160	9/16	76	56	122	90	176	130
5/8	136	100	217	160	305	225	5/8	106	78	170	125	217	160
3/4	238	175					3/4	190	140				
<ul style="list-style-type: none"> • Use 80% of the value when tightening part is aluminum. • Use 60% of the value for 4T bolts and lock nuts. 							<ul style="list-style-type: none"> • Use 80% of the value when tightening part is aluminum. • Use 60% of the value for 4T bolts and lock nuts. 						

1. Grade 2 applies for hex cap screws (not hex bolts) up to 152mm (6 in.) long.

2. Grade 2 applies for hex cap screws (not hex bolts) up to 152mm (6 in.) long.

Torque Values - Metric Hardware

Torque Values (Dry)							Torque Values (Lubricated)						
Size	Class 7		Class 8.8		Class 10.9		Size	Class 7		Class 8.8		Class 10.9	
	N•m	lb-ft	N•m	lb-ft	N•m	lb-ft		N•m	lb-ft	N•m	lb-ft	N•m	lb-ft
M6			11	8.1	17	12.5	M6			9	6.6	13	9.6
M8	29	21	35	26	41	30	M8	23	17	25	18.5	29	21.4
M10	59	44	67	49	80	59	M10	44	33	51	38	61	45
M12	98	72	113	83	132	97	M12	78	58	83	61	103	76
M14	147	108	167	123	201	148	M14	118	87	127	94	152	112
M16	206	152					M16	167	123				
<ul style="list-style-type: none"> • Use 80% of the value when tightening part is aluminum. • Use 60% of the value for 4T bolts and lock nuts. 							<ul style="list-style-type: none"> • Use 80% of the value when tightening part is aluminum. • Use 60% of the value for 4T bolts and lock nuts. 						

Warranty

Product Warranty

Product warranty is provided as part of John Deere's support program for customers who operate and maintain their equipment as described in this manual.

Engine related warranties stated in this manual refer only to emissions-related parts and components of your engine. The complete engine warranty, less emission-related parts and components, is provided separately as the Limited Warranty for New John Deere Commercial & Consumer Equipment.

John Deere, Federal And California Emission Control System Warranty (Non-Road Diesel)

Your Warranty Rights and Obligations

The United States Environmental Protection Agency (EPA), the California Air Resources Board (CARB) and John Deere are pleased to explain the emission control system warranty on your 1995 and later non-road diesel equipment engine. In California, 1995 and later non-road diesel equipment engines must be designed, built and equipped to meet the State's stringent anti-smog standards. In other states, 1997 and later model year equipment engines must be designed, built and equipped to meet the U.S. EPA regulations for non-road diesel engines. John Deere must warrant the emission control system on your non-road diesel equipment engine for the periods of time listed below provided there has been no abuse, neglect or improper maintenance of your non-road diesel equipment engine.

Your emission control system may include parts such as the fuel-injection system and the air induction system. Also included may be connectors and other emission related assemblies.

Where a warrantable condition exists, John Deere will repair your non-road diesel equipment engine at no cost to you including diagnosis, parts and labor.

John Deere Emission Control System Warranty Coverage

In California, 1995 and later non-road diesel equipment engine emissions control-related parts are warranted by John Deere for two years or 1500 hours of operation, whichever occurs first. In other states, 1997 and later non-road diesel equipment engine emissions control-related parts are warranted by John Deere for two years or 1500 hours of operation, whichever occurs first. If any emission related part on your engine is defective, the part will be repaired or replaced by John Deere.

Owner's Warranty Responsibilities

As the non-road diesel equipment engine owner, you are responsible for the performance of the required maintenance listed in your owner's manual. John Deere recommends that you retain all receipts covering maintenance on your non-road diesel equipment engine, but John Deere cannot deny warranty solely for lack of receipts or for your failure to ensure all scheduled maintenance is performed.

As the non-road diesel equipment engine owner, you should however be aware that John Deere may deny you warranty coverage if your non-road diesel equipment engine or a part has failed due to abuse, neglect, improper maintenance or unapproved modifications.

You are responsible for presenting your non-road diesel equipment engine to an authorized John Deere Commercial and Consumer Equipment Retailer as soon as a problem exists. The warranty repairs should be completed in a reasonable amount of time, not to exceed 30 days.

If you have any questions regarding your warranty rights and responsibilities, you should contact your John Deere Commercial and Consumer Equipment Retailer, or the John Deere Customer Contact

Center, 1-800-537-8233.

Length of Warranty Coverage

John Deere warrants to the initial owner and each subsequent purchaser that the non-road diesel equipment engine is:

- Designed, built and equipped so as to conform with all applicable regulations adopted by the California Air Resources Board (CARB) for 1995 and later equipment engines, and all applicable regulations of the United States Environmental Protection Agency (EPA) for 1997 and later equipment engines; and
- Free from defects in materials and workmanship which can cause the failure of an emission warranted part for a period of two years or 1500 hours of operation, whichever occurs first, after the engine is delivered to the initial retail purchaser. John Deere is liable for damages to other engine components caused by the failure of a warranted part during the warranty period. If any emission related part on your engine is defective, the part will be repaired or replaced by John Deere.

Warranted Parts

Coverage under this warranty extends only to the parts listed below (the emission control system parts) to the extent these parts were present on the engine purchased.

Fuel Metering System:

- Fuel injection system.

Air Induction System:

- Air Cleaner
- Turbocharger system.
- Intake manifold.

Diesel System:

- Exhaust manifold.

Miscellaneous Items Used in Above Systems:

- Hoses, belts, connectors and assemblies.

Since emission related parts may vary slightly from model to model, certain models may not contain all of these parts and certain models may contain functionally equivalent parts.

Warranty Service and Charges

Warranty service shall be provided during customary business hours at any authorized John Deere Commercial and Consumer Equipment Retailer. Repair or replacement of any warranted part will be performed at no charge to the owner, including diagnostic labor which leads to the determination that a warranted part is defective, if the diagnostic work is performed at an authorized John Deere Commercial and Consumer Equipment Retailer. Any parts replaced under this warranty shall become the property of John Deere.

Maintenance Warranty Coverage

a) Any warranted part which is not scheduled for replacement as required maintenance shall be warranted as to defects for the warranty period. Any such part repaired or replaced under the warranty shall be warranted for the remaining warranty period.

b) Any warranted part which is scheduled only for regular inspection to the effect of "repair or replace as necessary" shall be warranted as to defects for the warranty period. Any such part repaired or replaced under the warranty shall be warranted for the remaining warranty period.

c) Any warranted part which is scheduled for replacement as required

Warranty

maintenance shall be warranted as to defects only for the period of time up to the first scheduled replacement for that part. Any such part repaired or replaced under the warranty shall be warranted for the remainder of the period prior to the first scheduled replacement point for that part.

d) Normal maintenance, replacement or repair of emission control devices and systems, which are being done at the customer's expense, may be performed by any repair establishment or individual; however, warranty repairs must be performed by an authorized John Deere Commercial and Consumer Equipment Retailer.

e) Any replacement part that is equivalent in performance and durability may be used in the performance of any non-warranty maintenance or repairs, and shall not reduce the warranty obligations of John Deere.

Consequential Warranty Coverage

Warranty coverage shall extend to the failure of any engine components caused by the failure of any warranted part still under warranty.

Limitations

This Emission Control System Warranty shall NOT cover any of the following:

- a) Repair or replacement required as a result of (i) misuse or neglect, (ii) improper maintenance or unapproved modifications, (iii) repairs improperly performed or replacements improperly installed, (iv) use of replacement parts or accessories not conforming to John Deere specifications which adversely affect performance and/or durability, (v) alterations or modifications not recommended or approved in writing by John Deere.
- b) Replacement parts, other services and adjustments necessary for normal maintenance.
- c) Transportation to and from the John Deere Commercial and Consumer Equipment Retailer, or service calls made by the Retailer.

Limited Liability

a) The liability of John Deere under this Emission Control System Warranty is limited solely to the remedying of defects in materials or workmanship. This warranty does not cover inconvenience or loss of use of the non-road diesel equipment engine or transportation of the engine to or from the John Deere Commercial and Consumer Equipment Retailer. JOHN DEERE SHALL NOT BE LIABLE FOR ANY OTHER EXPENSE, LOSS, OR DAMAGE, WHETHER DIRECT, INCIDENTAL, CONSEQUENTIAL (EXCEPT AS LISTED ABOVE UNDER "COVERAGE") OR EXEMPLARY ARISING IN CONNECTION WITH THE SALE OR USE OF OR INABILITY TO USE THE NON-ROAD DIESEL ENGINE FOR ANY OTHER PURPOSE.

b) NO EXPRESS EMISSION CONTROL SYSTEM WARRANTY IS GIVEN BY JOHN DEERE WITH RESPECT TO THE ENGINE EXCEPT AS SPECIFICALLY SET FORTH IN THIS DOCUMENT. ANY EMISSION CONTROL SYSTEM WARRANTY IMPLIED BY LAW, INCLUDING ANY WARRANTY OF MERCHANTABILITY OR FITNESS FOR A PARTICULAR PURPOSE, IS EXPRESSLY LIMITED TO THE EMISSION CONTROL SYSTEM WARRANTY TERMS SET FORTH IN THIS DOCUMENT.

c) No dealer is authorized to modify this Federal, California and John Deere Emission Control System Warranty.

Tire Warranty

John Deere warranty applies for tires available through the John Deere parts system. For tires not available through the John Deere parts system, the tire manufacturer's warranty applicable to your machine may not apply

outside the U.S. (See your John Deere dealer for specific information.)

Limited Battery Warranty

NOTE: Applicable in North America only. For complete machine warranty, reference a copy of the John Deere warranty statement. Contact your John Deere dealer to obtain a copy.

TO SECURE WARRANTY SERVICE

The purchaser must request warranty service from a John Deere dealer authorized to sell John Deere batteries, and present the battery to the dealer with the top cover plate codes intact.

FREE REPLACEMENT

Any new battery which becomes unserviceable (not merely discharged) due to defects in material or workmanship within 90 days of purchase will be replaced free of charge. Installation costs will be covered by warranty if (1) the unserviceable battery was installed by a John Deere factory or dealer, (2) failure occurs within 90 days of purchase, and (3) the replacement battery is installed by a John Deere dealer.

PRO RATA ADJUSTMENT

Any new battery which becomes unserviceable (not merely discharged) due to defects in material or workmanship more than 90 days after purchase, but before the expiration of the applicable adjustment period, will be replaced upon payment of the battery's current list price less a pro rata credit for unused months of service. The applicable adjustment period is determined from the Warranty Code printed at the top of the battery and chart below. Installation costs are not covered by warranty after 90 days from the date of purchase.

THIS WARRANTY DOES NOT COVER

- A. Breakage of the container, cover, or terminals.
- B. Depreciation or damage caused by lack of reasonable and necessary maintenance or by improper maintenance.
- C. Transportation, mailing, or service call charges for warranty service.

LIMITATION OF IMPLIED WARRANTIES AND PURCHASER'S REMEDIES

To the extent permitted by law, neither John Deere nor any company affiliated with it makes any warranties, representations, or promises as to the quality, performance or freedom from defect of the products covered by this warranty. IMPLIED WARRANTIES OF MERCHANTABILITY AND FITNESS FOR A PARTICULAR PURPOSE, TO THE EXTENT APPLICABLE, SHALL BE LIMITED IN DURATION TO THE APPLICABLE ADJUSTMENT PERIOD SET FORTH HERE. THE PURCHASER'S ONLY REMEDIES IN CONNECTION WITH THE BREACH OR PERFORMANCE OF ANY WARRANTY ON JOHN DEERE BATTERIES ARE THOSE SET FORTH HERE. IN NO EVENT WILL THE DEALER, JOHN DEERE OR ANY COMPANY AFFILIATED WITH JOHN DEERE BE LIABLE FOR INCIDENTAL OR CONSEQUENTIAL DAMAGES. (Note: Some states do not allow limitations on how long an implied warranty lasts or the exclusion or limitation of incidental or consequential damages. So these limitations and exclusions may not apply to you.) This warranty gives you specific legal rights, and you may also have some rights which vary from state to state.

NO DEALER WARRANTY

The selling dealer makes no warranty of its own and the dealer has no authority to make any representation or promise on behalf of John Deere, or to modify the terms or limitations of this warranty in any way.

Warranty

PRO RATA MONTHS OF ADJUSTMENT

NOTE: If your battery is not labeled with a warranty code, it is a warranty code B.

Warranty Code	Warranty Period
A	40 Months
B	36 Months
C	24 Months

Index

Numerics

3-Point Hitch	71
3-Point Hitch, Lubricating	36
3-Point Hitch, Using	22

A

Air Filter Elements, Servicing	40
Air Filter Intake Hoses and Clamps, Checking	41
Air Restriction Indicator (1026R Only), Checking	39
Alternator Belt, Servicing	44
Axle, Front, Changing Oil	47
Axle, Front, Checking Oil Level	47

B

Ballast Box, Using Optional Rear	27
Ballasting Machine	27
Battery and Terminals, Cleaning	54
Battery, Removing and Installing	53
Battery, Service Safely	53
Battery, Using Booster	54
Belt, Servicing the Alternator	44
Bio-Diesel Fuel, Using	59
Brake Pedal, Using	14
Brake, Using Park	14
Bulb, Replacing Headlight	55
Bulb, Replacing Taillight	55
Bulb, Replacing Worklight (1026R)	56

C

Chain, Using Safety	30
Checklist, Daily Operating	11
Cold Weather Starting Aids	17
Controls, Operator Station	10
Coolant, Engine	41
Cooling System, Checking	42
Cooling System, Draining	42
Cooling System, Filling	43
Cooling System, Flushing	42
Cooling System, Service Safely	41
Cooling System, Servicing	42
Cruise Control, Using	18

D

Diesel Fuel, Using	59
Differential Lock, Using	19
Draft Links, Using	23
Drop/Lock Valve, Using Rate of	23
Dust Unloading Valve, Cleaning	39

E

Electrolyte Level, Checking Battery	53
Emergency Stopping	18
Engine Speeds, Checking	37
Engine Warranty Maintenance Statement	37

Engine, Starting	16
Engine, Starting Stalled	17
Engine, Warming and Idling	17

F

Filter, Changing Engine Oil and	38
Filter, Replacing Fuel	45
Front Grille, Cleaning	46
Front Weights, Using Optional	28
Front Wheel Drive (MFWD), Using Mechanical	19
Fuel Filter Sediment Bowl, Checking and Cleaning	45
Fuel Filter, Replacing	45
Fuel Gauge, Using	15
Fuel Injection Nozzles	46
Fuel Injection Pump	46
Fuel Safety	9
Fuel Shut-Off Valve, Using	16
Fuel Storage	68
Fuel Tank, Filling	59
Fuses, Replacing	56

G

Grease	35
Grease Fittings, Lubricating	35

H

Headlight Bulb, Replacing	55
Hitch Loads, Maximum	22
Hitch System, Using iMatch Quick-Attach (Optional)	24
Hitch, 3-Point	71
Hitch, Rear, Using	22
Hood, Raising and Lowering	60
Hoses and Clamps, Checking Air Filter Intake	41
Hoses and Clamps, Checking Radiator	43
Hydraulic Dual Selective Control Valve (SCV), Using	26
Hydraulic Hoses, Connecting Implement	25
Hydraulic Oil	47
Hydrostatic Transmission, Operating	18

I

iMatch Quick-Attach Hitch System (Optional), Using	24
Implement Hydraulic Hoses, Connecting	25
Implement Side-to-Side Sway, Adjusting	24
Implement, Leveling, Front-to-Rear	23
Implement, Leveling, Side-to-Side	24
Implement, Raising and Lowering	22
Instrument Panel, Using	13

K

Key Switch, Using	12
-------------------------	----

L

Light Switch, Using	12
Liquid Weight in Tires, Using	28
Literature, Service	32
Loads, Hitch, Maximum	22
Loads, Towing	29

Index

Lock Lever, Using Selective Control Valve (SCV)	27	Service Literature	32
M		Side Panels, Removing and Installing	60
Machine, Stopping	17	Spark Arrestor, Using	5
Mechanical Front Wheel Drive (MFWD), Using	19	Specifications	69
Metal Surfaces, Repairing and Cleaning	62	Stopping, Emergency	18
Mower Height Control Knob, Using	12	Storage, Removing Machine From	68
N		Storing Safety	68
Nozzles, Fuel Injection	46	T	
O		Taillight Bulb, Replacing	55
Oil Level, Checking Engine	37	Technical Manual	32
Oil Level, Checking Transmission	48	Throttle, Using	15
Oil Suction Screen, Remove and Install Transmission ..	50	Tilt Steering Wheel, Adjusting	11
Oil and Filter, Changing Engine	38	Tire Rolling Direction, Selecting Front	62
Oil and Filter, Changing Transmission	49	Towing Loads	29
Oil, Changing Front Axle	47	Traction Assist, Using	19
Oil, Engine	37	Transmission Oil	47
Oil, Transmission and Hydraulic	47	Transmission Oil Level, Checking	48
Operator Station Controls	10	Transmission Oil and Filter, Changing	49
P		Transmission, Operating Hydrostatic	18
PTO Driveshaft Length, Checking	20	Transporting Machine	29
Park Brake, Using	14	Transporting Machine on Trailer	28
Parking	6	Troubleshooting Chart, Using	63
Parts Catalog	32	Turn Signal Switch, Using	13
Parts, Replacement	32	W	
Plastic And Painted Surfaces, Avoid Damage To	11	Warranty Maintenance Statement, Engine	37
Plastic Surfaces, Cleaning	62	Warranty, Product	73
Power-Take-Off (PTO), Using Rear and Mid	21	Weight in Tires, Using Liquid	28
Power-Take-Off (PTO), Using Safely	20	Weights, Using Optional Front	28
Pump, Fuel Injection	46	Wheel Bolts and Hardware, Checking	61
Q		Wheel Weights, Using Optional Rear Cast Iron	27
Quick-Attach Hitch System (Optional), Using iMatch	24	Wheels, Removing and Installing	61
R			
ROPS, Raising and Lowering	30		
Radiator Cooling Screen and Fins, Cleaning	43		
Radiator Hoses and Clamps, Checking	43		
Rear Ballast Box, Using Optional	27		
Rear Hitch, Using	22		
Rockshaft Control Lever, Using	22		
S			
Safety Systems, Testing	14		
Safety, Tire	8		
Screen, Remove and Install Transmission Oil Suction ..	50		
Screens, Cleaning Front Grille	46		
Seat Belt, Adjusting	11		
Seat Belt, Using	11		
Seat, Adjusting	11		
Selective Control Valve (SCV) Linkage, Lubricating Hydraul	ic		
	36		
Selective Control Valve (SCV) Lock Lever, Using	27		
Selective Control Valve (SCV), Using Hydraulic Dual	26		

Notes

John Deere Quality Statement

John Deere Quality



John Deere equipment is more than just a purchase, it's an investment in quality. That quality goes beyond our equipment to your John Deere dealer's parts and service support. This support is needed to keep you a satisfied customer.

That's why John Deere has initiated a process to handle your questions or problems, should they arise. The following three steps will help guide you through the process.

Step 1

Refer to your operator's manual

- A. It has many illustrations and detailed information on the safe and proper operation of your equipment.
- B. It gives troubleshooting procedures, and specification information.
- C. It gives ordering information for parts catalogs, service and technical manuals.
- D. If your questions are not answered in the operator's manual, then go to Step 2.

Step 2

Contact your dealer

- A. Your John Deere dealer has the responsibility, authority, and ability to answer questions, resolve problems, and fulfill your parts and service needs.
- B. First, discuss your questions or problems with your dealer's trained parts and service staff.
- C. If the parts and service people are unable to resolve your problem, see the dealership manager or owner.
- D. If your questions or problems are not resolved by the dealer, then go to Step 3.

Step 3

Call the John Deere Customer Contact Center

- A. Your John Deere dealer is the most efficient source in addressing any concern, but if you are not able to resolve your problem after checking your operator's manual and contacting your dealer, call the Customer Contact Center.
- B. For prompt, effective service, please have the following ready before you call:
 - The name of the dealer with whom you've been working.
 - Your equipment model number.
 - Number of hours on machine (if applicable).
 - Your serial number which you recorded on the inside front cover of this manual.
 - If the problem is with an attachment, your attachment identification number.
- C. Then call 1-800-537-8233 and our advisor will work with your dealer to investigate your concern.

