

**3025E and 3038E
Compact Utility Tractors
Operator's Manual (Export)**



JOHN DEERE

OPERATOR'S MANUAL

**3025E and 3038E Compact Utility
Tractors (Export)**

OMTR111962 ISSUE I0 (ENGLISH)



John Deere Augusta Works
Export Edition
PRINTED IN U.S.A.

Introduction

Foreword

READ THIS MANUAL carefully to learn how to operate and service your machine correctly. Failure to do so could result in personal injury or equipment damage. This manual and safety signs on your machine may also be available in other languages. (See your John Deere dealer to order.)

THIS MANUAL SHOULD BE CONSIDERED a permanent part of your machine and should remain with the machine when you sell it.

MEASUREMENTS in this manual are given in both metric and customary U.S. unit equivalents. Use only correct replacement parts and fasteners. Metric and inch fasteners may require a specific metric or inch wrench.

RIGHT-HAND AND LEFT-HAND sides are determined by facing in the direction of forward travel.

WRITE PRODUCT IDENTIFICATION NUMBERS (P.I. N.) in the Specification or Identification Numbers section. Accurately record all the numbers to help in tracing the machine should it be stolen. Your dealer also needs these numbers when you order parts. File the identification numbers in a secure place off the machine.

WARRANTY is provided as part of John Deere's support program for customers who operate and maintain their equipment as described in this manual. The warranty is explained on the warranty certificate or statement which you should have received from your dealer.

This warranty provides you the assurance that John Deere will back its products where defects appear within the warranty period. In some circumstances, John Deere also provides field improvements, often without charge to the customer, even if the product is out of warranty. Should the equipment be abused, or modified to change its performance beyond the original factory specifications, the warranty will become void and field improvements may be denied. Setting fuel delivery above specifications or otherwise overpowering machines will result in such action.

THE TIRE MANUFACTURER'S warranty supplied with your machine may not apply outside the U.S.

If you are not the original owner of this machine, it is in your interest to contact your local John Deere dealer to inform them of this unit's serial number. This will help John Deere notify you of any issues or product improvements.

Contents

	Page	Page
General Information		
Product View	00-1	
Trademarks	00-1	
Glossary of Terms	00-1	
Regions and Country Versions	00-2	
Machine Overview	00-3	
Safety		
Recognize Safety Information	00A-1	
Understand Signal Words	00A-1	
Follow Safety Instructions	00A-1	
Prepare for Emergencies	00A-1	
Wear Protective Clothing	00A-2	
Protect Against Noise	00A-2	
Handle Fuel Safely—Avoid Fires	00A-2	
Handle Starting Fluid Safely	00A-2	
Fire Prevention	00A-3	
In Case of Fire	00A-3	
Avoid Static Electricity Risk When Refueling	00A-4	
Keep ROPS Installed Properly	00A-4	
Use Foldable ROPS and Seat Belt Properly	00A-4	
Stay Clear of Rotating Drivelines	00A-5	
Use Steps and Handholds Correctly	00A-5	
Read Operator's Manuals for ISOBUS Controllers	00A-6	
Use Seat Belt Properly	00A-6	
Operating the Tractor Safely	00A-6	
Avoid Backover Accidents	00A-7	
Limited Use in Forestry Operation	00A-7	
Operating the Loader Tractor Safely	00A-8	
Keep Riders Off Machine	00A-8	
Instructional Seat	00A-8	
Use Safety Lights and Devices	00A-9	
Transport Towed Equipment at Safe Speeds	00A-9	
Use Caution on Slopes, Uneven Terrain, and Rough Ground	00A-10	
Freeing a Mired Machine	00A-10	
Avoid Contact with Agricultural Chemicals	00A-11	
Handle Agricultural Chemicals Safely	00A-11	
Handling Batteries Safely	00A-12	
Avoid Heating Near Pressurized Fluid Lines	00A-12	
Remove Paint Before Welding or Heating	00A-13	
Handle Electronic Components and Brackets Safely	00A-13	
Practice Safe Maintenance	00A-13	
Avoid Hot Exhaust	00A-14	
Clean Exhaust Filter Safely	00A-14	
Work In Ventilated Area	00A-15	
Support Machine Properly	00A-15	
Prevent Machine Runaway	00A-15	
Park Machine Safely	00A-16	
Transport Tractor Safely	00A-16	
Service Cooling System Safely	00A-16	
Service Accumulator Systems Safely	00A-16	
Service Tires Safely	00A-17	
Service Front-Wheel Drive Tractor Safely	00A-17	
Tightening Wheel Retaining Bolts/Nuts	00A-17	
Avoid High-Pressure Fluids	00A-17	
Do Not Open High-Pressure Fuel System	00A-18	
Store Attachments Safely	00A-18	
Decommissioning — Proper Recycling and Disposal of Fluids and Components	00A-18	
Safety Signs		
Replace Safety Signs	00B-1	
ROPS in Normal Position, Riders, and Operator's Manual	00B-1	
Folding ROPS	00B-1	
Use Seat Belt	00B-2	
Noise	00B-2	
Controls and Instruments		
Front Console Controls	10-1	
Foot-Operated Controls	10-1	
Right-Hand Console Controls	10-3	
Left-Hand Console Controls	10-4	
MFWD, Rate-of-Drop, and Seat Controls	10-5	
Instrument Cluster	10-6	
Information Display Icons	10-8	
Information Display and Display Mode Switch	10-9	
Engine Operation		
Operate Key Switch	20-1	
Operate Throttle	20-1	
Operate Fuel Shutoff Valve	20-1	
Start the Engine	20-1	
Cold Weather Starting Aids	20-2	
Warm and Idle the Engine	20-2	
To Start a Stalled Engine	20-3	
Stop Engine	20-3	
Air Intake, Fuel, Coolant, and Exhaust Operation		
Using Fuel Shutoff Valve	30-1	
Fill the Fuel Tank	30-1	
Use Fuel Gauge	30-1	
Electrical and Lighting Operation		
Turn Signal and Hazard Lights	40-1	
Road, Work, and Warning Lights	40-1	
Use Power Port Outlet	40-2	

Continued on next page

Original Instructions. All information, illustrations and specifications in this manual are based on the latest information available at the time of publication. The right is reserved to make changes at any time without notice.

Contents

	Page		Page
Drivetrain Operation		Additional Equipment Operation	
Drive Machine	50-1	Additional Equipment Operation	80B-1
		Front Loader Installation	80B-1
Transmission Operation		Operator Station Operation	
Operate the Hydrostatic Transmission	50A-1	Enter and Exit Machine	90-1
Operating Cruise Control (If equipped)	50A-1	Adjust Seat	90-1
		Use Seat Belt	90-1
MFWD and Front Axle Operation		Roll Over Protection Structure (ROPS)	90-1
Use Mechanical Front Wheel Drive (MFWD)	50B-1	Using Horn	90-2
Differential and Rear Axle Operation		Transport and Storage	
Use Brake/Differential Lock Pedal (Traction Assist)	50C-1	Transport Machine on Trailer	100-1
		Transport Machine	100-1
Power Take Off (PTO) Operation		Push or Tow Machine	100-1
Operate Rear Power-Take-Off (PTO)	50D-1	Tow Loads	100-2
		Store Safety	100-2
Steering and Brake Operation		Prepare Machine for Storage	100-2
Operate Brake/Differential Lock Pedal	60-1	Prepare Fuel and Engine for Storage	100-2
Operate Park Brake	60-1	Remove Machine from Storage	100-3
		Battery Isolation / Disconnect	100-3
Hydraulics Operation		Maintenance Intervals	
Warm Hydraulic System Oil	70-1	Service Your Machine	200-1
Hydraulics Information	70-1	Service Interval Charts	200-1
		Service Interval Charts	200-1
Hitch and Drawbar Operation		Test the Safety Interlock System Before Startup	200-2
Operate Attachments	70A-1	Avoid Damage to Plastic and Painted Surfaces	200-2
Operate 3-Point Hitch	70A-1	Clean Plastic Surfaces	200-3
Positioning Center Link	70A-2	Clean and Repair Metal Surfaces	200-3
Operate Rate-of-Drop	70A-2		
Use Draft Link and Center Link	70A-2	Fuel, Lubricants, and Coolant	
Level Implement Front-to-Rear	70A-3	Carbon Dioxide Emissions (CO ₂)	200A-1
Level Implement Side-to-Side	70A-3	Emissions Performance and Tampering	200A-1
Adjust Implement Side-to-Side Sway	70A-3	Diesel Fuel	200A-1
Operate Drawbar Hitch (If Equipped)	70A-4	Handling and Storing Diesel Fuel	200A-2
		Testing Diesel Fuel	200A-2
Selective Control Valve Operation		Minimizing the Effect of Cold Weather on Diesel Engines	200A-2
Connect Implement Hydraulic Hoses	70B-1	Alternative and Synthetic Lubricants	200A-3
Operate Selective Control Valve (SCV)	70B-1	Engine Oil	200A-3
Operate Selective Control Valve (SCV) Lock Lever	70B-1	Diesel Engine Coolant	200A-4
Operate Hydraulic Dual Rear (SCV) Selective Control Valve	70B-2	Operating in Warm Temperature Climates	200A-4
Operate Hydraulic Dual Rear (SCV) Lock Lever	70B-3	Additional Information About Diesel Engine Coolants and John Deere COOL-GARD™ II Coolant Extender	200A-5
		Testing Diesel Engine Coolant	200A-5
Wheels and Tires Operation		Transmission and Hydraulic Oil	200A-6
Tire Labeling, Ascertain the Load Capacity of Tires	80-1	Front Axle and MFWD Oil	200A-6
Select Tire Inflation Pressure	80-1		
Tire Combinations	80-2	Maintenance—As Required	
Front and Rear Tire Capacity	80-2	Service—As Required	200B-1
Ballast		Controls and Instruments Maintenance	
Ballast Machine	80A-1	Controls and Instruments Maintenance	210-1
Implement Codes	80A-1		
Tire Capacities	80A-1	Engine Maintenance	
Use Optional Rear Cast Iron Wheel Weights	80A-1	Required Emission-Related Information	220-1
Use Optional Rear Ballast Box	80A-2	Daily Startup Procedure	220-1
Use Liquid Weight in Tires	80A-2	Check Engine Oil Level	220-1
Use Optional Front Weights	80A-2	Change Engine Oil and Filter	220-2

	Page		Page
Clean Dust Unloading Valve	220-2	Selective Control Valve Maintenance	
Service the Alternator Belt	220-2	Check Selective Control Valve	270B-1
Clean Front and Side Grille Screens	220-3		
Clean Engine Compartment	220-3	Wheels and Tires Maintenance	
Air, Fuel, Coolant, and Exhaust Maintenance		Check Wheel Bolts and Hardware	280-1
Service Air Filter Elements	230-1	Remove and Install Wheels	280-1
Check Air Filter Hose	230-2	Check Tire Pressure	280-1
Checking and Cleaning Fuel Filter Sediment		Tire Inflation Pressure Chart	280-1
Bowl and Replacing Filter	230-2	Select Front Tire Rolling Direction	280-2
Fuel Injection Pump	230-3	Changing Wheel Spacing and Tread Width	280-2
Fuel Injection Nozzles	230-3	Lift Points for Jacking up the Tractor	280-2
Drain and Flush Fuel Tank	230-3		
Check Coolant Level	230-3	Ballast Maintenance	
Drain and Flush Cooling System	230-3	Match Ballast to Work Load	280A-1
Fill Cooling System	230-4		
Check Radiator Hoses and Clamps	230-5	Additional Equipment Maintenance	
Clean Radiator, Fuel, and Transmission		Additional Equipment Maintenance	280B-1
Cooling Fins	230-5		
Electrical and Lighting Maintenance		Operator Station Maintenance	
Service Electrical	240-1	Raise and Lower Hood	290-1
Prevent Battery Explosions	240-1	Remove and Install Side Panels	290-1
Remove and Install Battery	240-1	Hood Cowl Removal and Installation	290-1
Clean Battery and Terminals	240-1	Inspect ROPS for Loose Hardware	290-2
Use Booster Battery	240-2		
Replace Headlight Bulb	240-2	Troubleshooting	
Replacing Tail, Turn and Warning Light Bulbs	240-2	Information Display Fault Messages	300-1
Replacing Fuses and Relays	240-3	Engine	300-1
		Electrical System	300-4
Drivetrain Maintenance		Machine	300-5
Drivetrain Maintenance	250-1	Brakes	300-7
		Steering	300-7
Transmission Maintenance		On-Board Diagnostics	
Check Transmission Oil Level	250A-1	Service Alert and Information Display	300A-1
Change Transmission Oil and Filter	250A-1	On Board Diagnostic Display	300A-1
		On-Board Diagnostic (OBD) Tool	300A-1
MFWD and Front Axle Maintenance		Diagnostic Trouble Code (DTC)	300A-1
Check Front Axle Oil Level	250B-1	Come Home Mode	300A-2
Change Front Axle Oil	250B-1		
Adjusting Front Axle Thrust Bolt Torque	250B-2	Specifications	
Lubricating Axle Trunnion	250B-2	Engine Specifications	400-1
		Drivetrain Specifications	400-1
Differential and Rear Axle Maintenance		Hydraulic System Specifications	400-1
Rear Axle Maintenance	250C-1	Electrical System	400-2
		Fluid Capacities	400-2
Power Take Off (PTO) Maintenance		Ground Speeds	400-2
PTO Maintenance	250D-1	Dimensions	400-2
		Height from Ground	400-3
Steering and Brake Maintenance		Ground Clearance	400-3
Check and Adjust Toe-In	260-1	Machine Weight	400-3
Steering Maintenance	260-1	3-Point Hitch Specification	400-3
Brake Maintenance	260-1	Coupling Devices	400-3
		Sound Level	400-4
Hydraulics Maintenance		Seat Vibration	400-4
Hydraulic Maintenance	270-1	How to Calculate Maximum Permissible	
		Download on Trailer Hitch	400-4
Hitch and Drawbar Maintenance		How to Calculate Permissible Mass	400-5
Lubricate 3-Point Hitch (If Equipped)	270A-1	Unified Inch Bolt and Screw Torque Values	400-5
		Metric Bolt and Screw Torque Values	400-6
		Identification Numbers	
		Product Identification Information	400A-1

Page

Record Identification Numbers 400A-1

Certification and Warranty

Warranty 400B-1

Service Records

Every 10 Hour Service 500-1

Every 50 Hour Service 500-1

Every 200 Hour Service 500-1

Every 400 Hour Service 500-2

Every 600 Hour Service 500-2

Yearly 500-2

Every 1000 Hour Service 500-3

Every 2000 Hour Service or Every Two Years ... 500-3

Every 6000 Hour Service or Every Six Years 500-3

Change of Ownership 500-3

Change of Ownership 500-4

Change of Ownership 500-5

General Information

Product View



3038E Tractor

LV30683—UN—25NOV19

UP00731,0000A08-19-25NOV19

Trademarks

Trademarks	
GreenStar™	Trademark of Deere & Company
iMatch™	Trademark of Deere & Company
Quik-Tatch™	Trademark of Deere & Company
Cool-Gard™	Trademark of Deere & Company
Cool-Gard™ II	Trademark of Deere & Company
Plus-50™	Trademark of Deere & Company
Torq-Gard™	Trademark of Deere & Company
Hy-Gard™	Trademark of Deere & Company
SUPERLUBE™	Trademark of Synco Chemical Corp

SK35149,0001100-19-10JUL17

Glossary of Terms

Abbreviation	Description
DTC	Diagnostic Trouble Code
ECU	Engine Control Unit
MFWD	Mechanical Front-Wheel Drive

General Information

Abbreviation	Description
OBD	On-Board Diagnostic
PTO	Power Take-Off
RIO	Reverse Implement Option
ROPS	Roll-Over Protective Structure
SCV	Selective Control Valve

SK35149,0001101-19-10JUL17

Regions and Country Versions

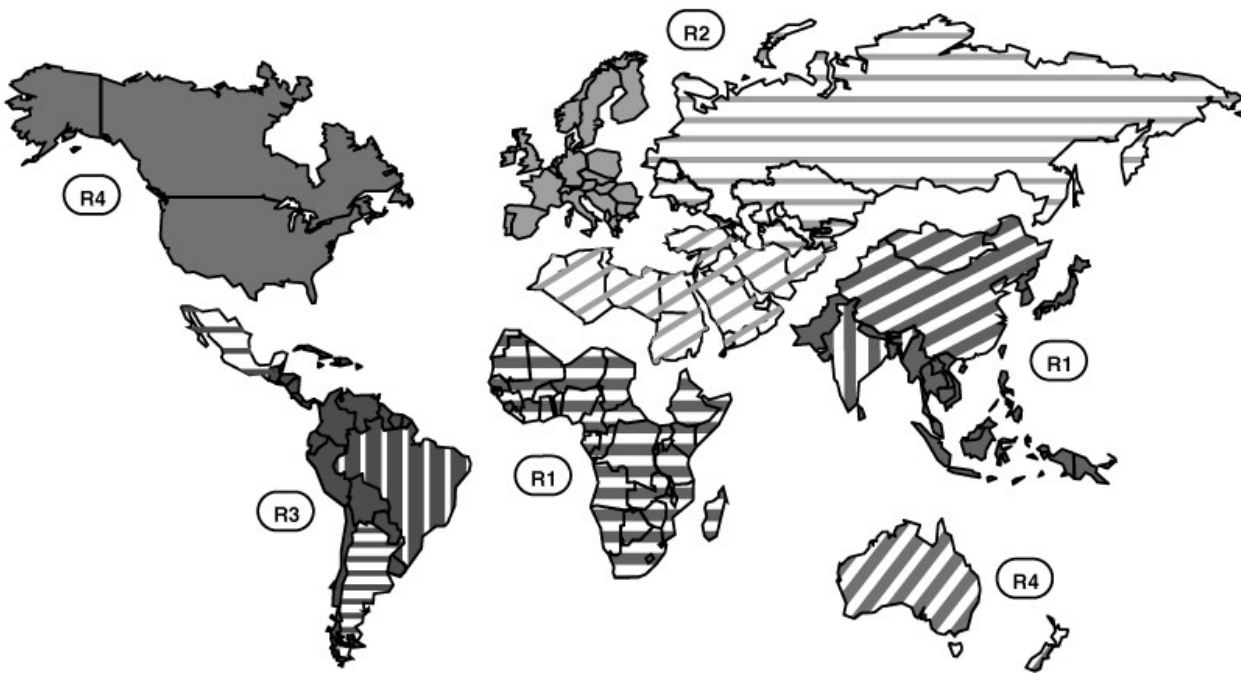

RXA0150915—UN—01FEB16

R1—Asia and Sub-Saharan Africa
 R1A—Far East, Sri Lanka and Pakistan
 R1B—China
 R1C—India
 R1D—Sub-Saharan Africa
 R2—Europe, North Africa, Mid East, CIS
 R2A—European Union (EU 28+)
 R2B—North Africa and North Middle East (NANME)
 R2C—Commonwealth of Independent States (CIS)

R3—Central and South America
 R3A—Latin America (JDLA)
 R3B—Brazil
 R3C—Mexico
 R3D—Argentina
 R4—North America
 R4A—USA and Canada
 R4B—Oceania (Australia and New Zealand)

General Information

Regions 1, 2 and 3 equipment is traditionally manufactured with Economic Commission for Europe (ECE) features or systems.

Region 4 equipment is traditionally manufactured with Society of Automotive Engineers (SAE) features or systems.

Drive and signal lighting, traffic signs, safety signs, and braking features are some of the systems that differ between ECE and SAE. For example, Text-Free (pictorial only) safety signs are used for ECE while Text with Picture safety signs are used on SAE.

Use information above, if equipment information is identified by regions, countries, trade federations, industry standards, or governmental regulations.

NOTE: Australia and New Zealand (R4B) are available as either region 4 and/or region 2 configurations, only using text-free safety signs.

SK35149,0001102-19-27AUG18

Machine Overview

IMPORTANT: READ THIS MANUAL carefully to learn how to operate and service your machine correctly. Failure to do so could result in personal injury or equipment damage. This manual and safety signs on your machine may available in other languages. See your John Deere dealer for specific language requirements and to place an order.)

Review manual sections for Controls and Instruments identification, Steering and Brakes, Transmission, and Transportation before operation on the road or in the field.

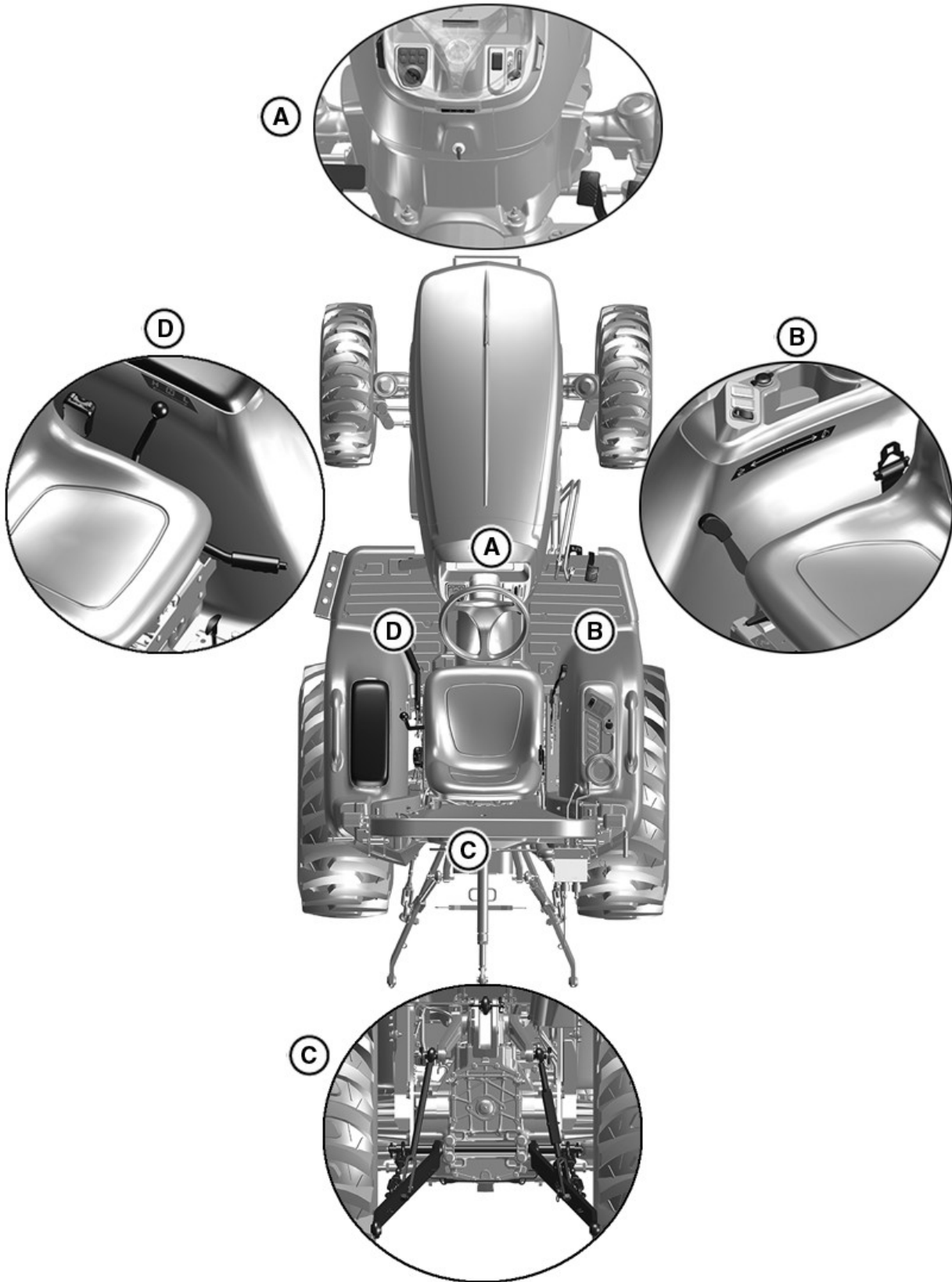

A—Front Console Controls
B—Right Side Controls

C—Rear Implement Interface
D—Left Side Controls

PY38939—UN—17JUL17

Operating the Machine Introduction:

See relevant section in the operator manual for operating procedures.

- Sit in the operator seat and fasten seat belt.
- Start engine.
- Turn on lights or signals as required.
- To move machine, operate the transmission.
- Use steering and brakes as required.
- Activate features and implements as required.

Preliminary Overview

Inspect the machine before operation, use the following list as a reminder. Detailed operation and service information is available in this operator manual.

- Review manual and machine for safety information and safety signs.
- Review manual for proper operation, adjustment, and service.
- Review manual for engine and drivetrain operations. (throttles, brakes, steering, transmission gears, MFWD, and Differential Lock.)
- Review manual for control devices (hitch, hydraulic, and electrical).
- Review manual for regular lubrication points and intervals.
- Check for visual signs of leaks, damage, failures, and flats.
- Prepare machine hardware, fuel, fluids, lubricants, air, and daily maintenance.
- Check and prepare implements or attachments according to implement or attachment operator manuals.

Using this Manual:

The information provided in this manual is divided into sections. The sections are organized with the typical machine features or functional systems together (Engine, Electrical, Hydraulic, Transmission, and so forth). These sections are identified at the top of each page. Specific information within each section is organized into modules. These modules are enclosed in boxes and the main modules are identified with a heading at the top left. Page numbers identify the section as well as the number of the page in the section.

By reviewing this manual frequently you learn which section to turn to for specific information. For example, the safety information is covered at the beginning, the operation of all features and systems is covered in the first half of the manual. Maintenance intervals are in the middle of the manual, the maintenance of all the features and systems is covered in the second half of the manual. The specifications are covered at the end.

A detailed table of contents appears before safety information and there is an alphabetical index at the very end of the manual.

The Operator's Manual content flows as sequential reading down one column of text and graphic then over to the top of the next column as shown.

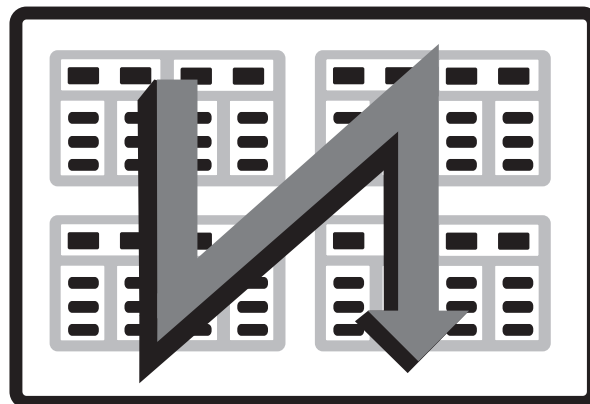

W28329—UN—18OCT17
GS25068,0003DCC-19-25JAN18

Safety

Recognize Safety Information



T81389—UN—28JUN13

This is a safety-alert symbol. When you see this symbol on your machine or in this manual, be alert to the potential for personal injury.

Follow recommended precautions and safe operating practices.

DX,ALERT-19-29SEP98

Follow Safety Instructions



TS201—UN—15APR13

Carefully read all safety messages in this manual and on your machine safety signs. Keep safety signs in good condition. Replace missing or damaged safety signs. Be sure new equipment components and repair parts include the current safety signs. Replacement safety signs are available from your John Deere dealer.

There can be additional safety information contained on parts and components sourced from suppliers that is not reproduced in this operator's manual.

Learn how to operate the machine and how to use controls properly. Do not let anyone operate without instruction.

Keep your machine in proper working condition. Unauthorized modifications to the machine may impair the function and/or safety and affect machine life.

If you do not understand any part of this manual and need assistance, contact your John Deere dealer.

DX,READ-19-16JUN09

Understand Signal Words



▲ WARNING

▲ CAUTION

TS187—19—30SEP88

DANGER; The signal word DANGER indicates a hazardous situation which, if not avoided, will result in death or serious injury.

WARNING; The signal word WARNING indicates a hazardous situation which, if not avoided, could result in death or serious injury.

CAUTION; The signal word CAUTION indicates a hazardous situation which, if not avoided, could result in minor or moderate injury. CAUTION may also be used to alert against unsafe practices associated with events which could lead to personal injury.

A signal word—DANGER, WARNING, or CAUTION—is used with the safety-alert symbol. DANGER identifies the most serious hazards. DANGER or WARNING safety signs are located near specific hazards. General precautions are listed on CAUTION safety signs. CAUTION also calls attention to safety messages in this manual.

DX,SIGNAL-19-05OCT16

Prepare for Emergencies

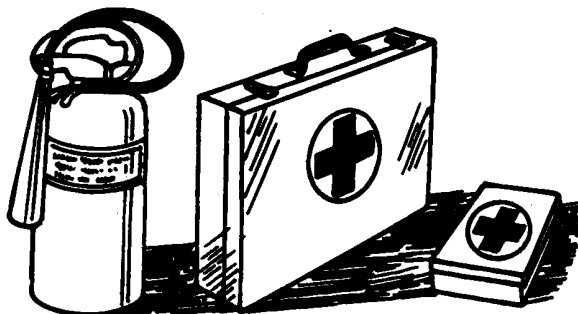

TS291—UN—15APR13

Be prepared if a fire starts.

Keep a first aid kit and fire extinguisher handy.

Keep emergency numbers for doctors, ambulance service, hospital, and fire department near your telephone.

DX,FIRE2-19-03MAR93

Wear Protective Clothing

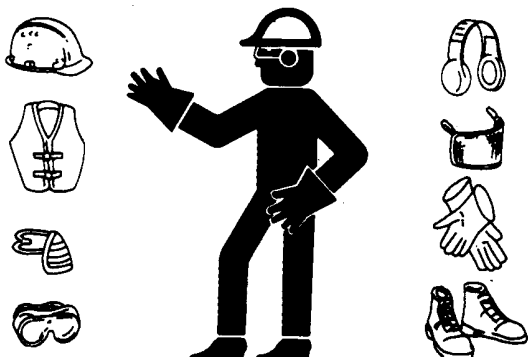

TS206—UN—15APR13

Wear close fitting clothing and safety equipment appropriate to the job.

Operating equipment safely requires the full attention of the operator. Do not wear radio or music headphones while operating machine.

DX.WEAR2-19-03MAR93

Handle Fuel Safely—Avoid Fires



TS202—UN—23AUG88

Handle fuel with care: it is highly flammable. Do not refuel the machine while smoking or when near open flame or sparks.

Always stop engine before refueling machine. Fill fuel tank outdoors.

Prevent fires by keeping machine clean of accumulated trash, grease, and debris. Always clean up spilled fuel.

Use only an approved fuel container for transporting flammable liquids.

Never fill fuel container in pickup truck with plastic bed liner. Always place fuel container on ground before refueling. Touch fuel container with fuel dispenser nozzle before removing can lid. Keep fuel dispenser nozzle in contact with fuel container inlet when filling.

Do not store fuel container where there is an open flame, spark, or pilot light such as within a water heater or other appliance.

DX.FIRE1-19-12OCT11

Protect Against Noise

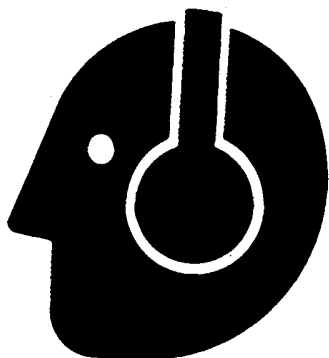

TS207—UN—23AUG88

There are many variables that affect the sound level range, including machine configuration, condition and maintenance level of the machine, ground surface, operating environmental, duty cycles, ambient noise, and attachments.

Exposure to loud noise can cause impairment or loss of hearing.

Always wear hearing protection. Wear a suitable hearing protective device such as earmuffs or earplugs to protect against objectionable or uncomfortable loud noises.

DX.NOISE-19-03OCT17

Handle Starting Fluid Safely



TS1356—UN—18MAR92

Starting fluid is highly flammable.

Keep all sparks and flame away when using it. Keep starting fluid away from batteries and cables.

To prevent accidental discharge when storing the pressurized can, keep the cap on the container, and store in a cool, protected location.

Do not incinerate or puncture a starting fluid container.

Do not use starting fluid on an engine equipped with glow plugs or an air intake heater.

DX,FIRE3-19-14MAR14

Fire Prevention

To reduce the risk of fire, your tractor should be regularly inspected and cleaned.

- Birds and other animals may build nests or bring other flammable materials into the engine compartment or onto the exhaust system. The tractor should be inspected and cleaned prior to the first use each day.
- A build up of grass, crop material and other debris may occur during normal operation. This is especially true when operating in very dry conditions or conditions where airborne crop material or crop dust is present. Any such build up must be removed to ensure proper machine function and to reduce the risk of fire. The tractor must be inspected and cleaned periodically throughout the day.
- Regular and thorough cleaning of the tractor combined with other routine maintenance procedures listed in the Operator's Manual greatly reduce the risk of fire and the chance of costly downtime.
- Do not store fuel container where there is an open flame, spark, or pilot light such as within a water heater or other appliance.
- Check fuel lines, tank, cap, and fittings frequently for damage, cracks or leaks. Replace if necessary.

Follow all operational and safety procedures posted on the machine and the Operator's Manual. Be careful of hot engine and exhaust components during inspection and cleaning. Before carrying out any inspection or cleaning, always shut OFF the engine, place the transmission in PARK or set parking brake, and remove the key. Removal of the key will prevent others from starting the tractor during inspection and cleaning.

DX,WW,TRACTOR,FIRE,PREVENTION-19-12OCT11

In Case of Fire



TS227—UN—15APR13

CAUTION: Avoid personal injury.

Stop machine immediately at the first sign of fire. Fire may be identified by the smell of smoke or sight of flames. Because fire grows and spreads rapidly, get off the machine immediately and move safely away from the fire. Do not return to the machine! The number one priority is safety.

Call the fire department. A portable fire extinguisher can put out a small fire or contain it until the fire department arrives; but portable extinguishers have limitations. Always put the safety of the operator and bystanders first. If attempting to extinguish a fire, keep your back to the wind with an unobstructed escape path so you can move away quickly if the fire cannot be extinguished.

Read the fire extinguisher instructions and become familiar with their location, parts, and operation before a fire starts. Local fire departments or fire equipment distributors may offer fire extinguisher training and recommendations.

If your extinguisher does not have instructions, follow these general guidelines:

1. Pull the pin. Hold the extinguisher with the nozzle pointing away from you, and release the locking mechanism.
2. Aim low. Point the extinguisher at the base of the fire.
3. Squeeze the lever slowly and evenly.
4. Sweep the nozzle from side-to-side.

DX,FIRE4-19-22AUG13

Avoid Static Electricity Risk When Refueling



RG22142—UN—17MAR14

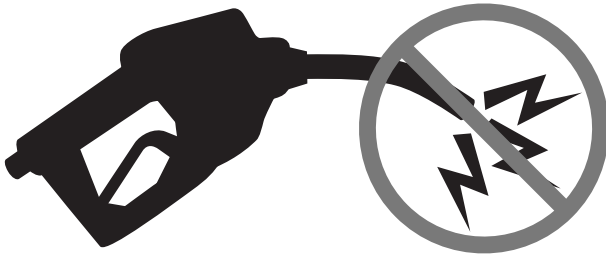

RG21992—UN—21AUG13

The removal of sulfur and other compounds in Ultra-Low Sulfur Diesel (ULSD) fuel decreases its conductivity and increases its ability to store a static charge.

Refineries may have treated the fuel with a static dissipating additive. However, there are many factors that can reduce the effectiveness of the additive over time.

Static charges can build up in ULSD fuel while it is flowing through fuel delivery systems. Static electricity discharge when combustible vapors are present could result in a fire or explosion.

Therefore, it is important to ensure that the entire system used to refuel your machine (fuel supply tank, transfer pump, transfer hose, nozzle, and others) is properly grounded and bonded. Consult with your fuel or fuel system supplier to ensure that the delivery system is in compliance with fueling standards for proper grounding and bonding practices.

DX,FUEL,STATIC,ELEC-19-12JUL13

Keep ROPS Installed Properly

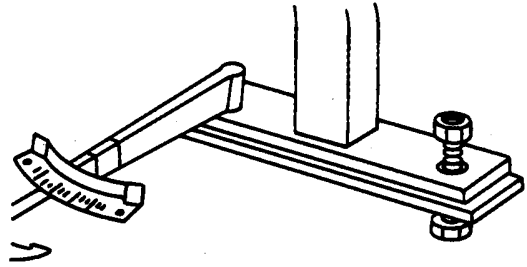

TS212—UN—23AUG88

Make certain all parts are reinstalled correctly if the roll-over protective structure (ROPS) is loosened or removed for any reason. Tighten mounting bolts to proper torque.

The protection offered by ROPS will be impaired if ROPS is subjected to structural damage, is involved in an overturn incident, or is in any way altered by welding, bending, drilling, or cutting. A damaged ROPS should be replaced, not reused.

The seat is part of the ROPS safety zone. Replace only with John Deere seat approved for your tractor.

Any alteration of the ROPS must be approved by the manufacturer.

DX,ROPS3-19-12OCT11

Use Foldable ROPS and Seat Belt Properly

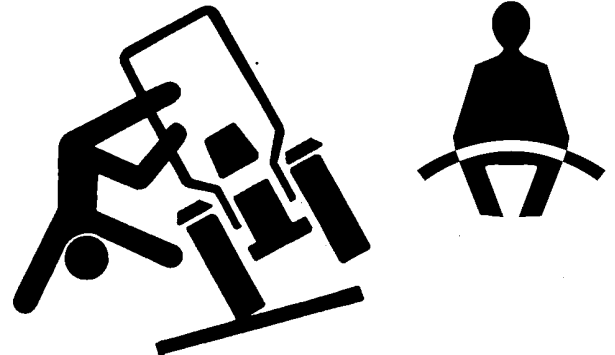

TS1729—UN—24MAY13

Avoid crushing injury or death during rollover.

- If this machine is equipped with a foldable rollover protective structure (ROPS), keep the ROPS in the fully extended and locked position. USE a seat belt when you operate with a ROPS in the fully extended position.
 - Hold the latch and pull the seat belt across the body.
 - Insert the latch into the buckle. Listen for a click.
 - Tug on the seat belt to make sure that the belt is securely fastened.

- Snug the seat belt across the hips.
- If this machine is operated with the ROPS folded (for example, to enter a low building), drive with extreme caution. **DO NOT USE** a seat belt with the ROPS folded.
- Return the ROPS to the raised, fully extended position as soon as the machine is operated under normal conditions.

DX,FOLDROPS-19-22AUG13

Stay Clear of Rotating Drivelines



TS1644—UN—22AUG95

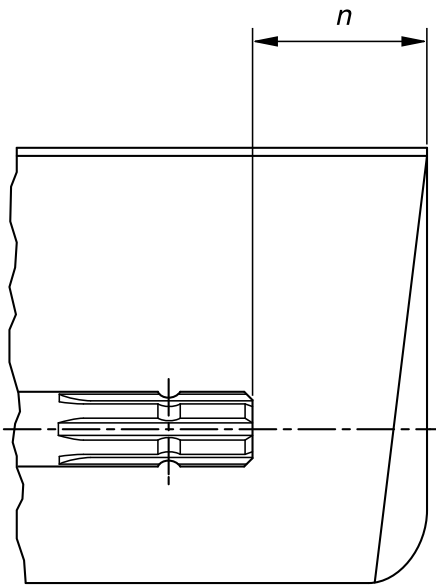

H96219—UN—29APR10

Entanglement in rotating driveline can cause serious injury or death.

Keep tractor master shield and driveline shields in place at all times. Make sure rotating shields turn freely.

Only use power take-off driveshfts with adequate guards and shields.

Wear close fitting clothing. Stop the engine and be sure that PTO driveline is stopped before making

adjustments, connections, or cleaning out PTO driven equipment.

Do not install any adapter device between the tractor and the primary implement PTO driveshaft that will allow a 1000 rpm tractor shaft to power a 540 rpm implement at speeds higher than 540 rpm.

Do not install any adapter device that results in a portion of the rotating implement shaft, tractor shaft, or the adapter to be unguarded. The tractor master shield shall overlap the end of the splined shaft and the added adaptor device as outlined in the table.

The angle at which the primary implement PTO driveshaft can be inclined may be reduced depending on the shape and size of the tractor master shield and the shape and size of the guard of the primary implement PTO driveshaft.

Do not raise implements high enough to damage the tractor master shield or guard of primary implement PTO driveshaft. Detach the PTO driveline shaft if it is necessary to increase implement height. (See Attching/ Detaching PTO Driveline)

When using Type 3/4 PTO, inclination and turning angles may be reduced depending on type of PTO master shield and coupling rails.

PTO Type	Diameter	Splines	$n \pm 5 \text{ mm (0.20 in.)}$
1	35 mm (1.378 in.)	6	85 mm (3.35 in.)
2	35 mm (1.378 in.)	21	85 mm (3.35 in.)
3	45 mm (1.772 in.)	20	100 mm (4.00 in.)
4	57.5 mm (2.264 in.)	22	100 mm (4.00 in.)

DX,PTO-19-28FEB17

Use Steps and Handholds Correctly

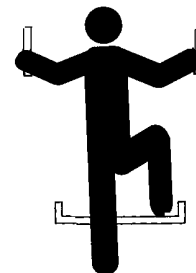

T133468—UN—15APR13

Prevent falls by facing the machine when getting on and off. Maintain 3-point contact with steps, handholds, and handrails.

Use extra care when mud, snow, or moisture present slippery conditions. Keep steps clean and free of grease

or oil. Never jump when exiting machine. Never mount or dismount a moving machine.

DX,WW,MOUNT-19-12OCT11

Read Operator's Manuals for ISOBUS Controllers

In addition to GreenStar™ Applications, this display can be used as a display device for any ISOBUS Controller that meets ISO 11783 standard. This includes capability to control ISOBUS implements. When used in this manner, information and control functions placed on the display are provided by the ISOBUS Controller and are the responsibility of the ISOBUS Controller manufacturer. Some of these functions could pose a hazard to either the operator or a bystander. Read the Operator's Manual provided by the ISOBUS Controller manufacturer and observe all safety messages in manual and on ISOBUS Controller product prior to use.

NOTE: ISOBUS refers to the ISO Standard 11783

DX,WW,ISOBUS-19-15JUL15

Use Seat Belt Properly

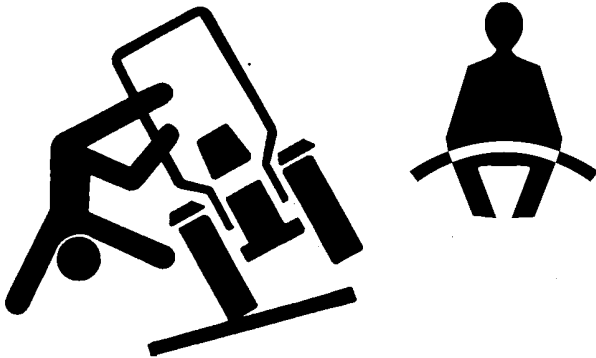

TS1729—UN—24MAY13

Avoid crushing injury or death during rollover.

This machine is equipped with a rollover protective structure (ROPS). USE a seat belt when you operate with a ROPS.

- Hold the latch and pull the seat belt across the body.
- Insert the latch into the buckle. Listen for a click.
- Tug on the seat belt latch to make sure that the belt is securely fastened.
- Snug the seat belt across the hips.

Replace entire seat belt if mounting hardware, buckle, belt, or retractor show signs of damage.

Inspect seat belt and mounting hardware at least once a year. Look for signs of loose hardware or belt damage,

GreenStar is a trademark of Deere & Company

such as cuts, fraying, extreme or unusual wear, discoloration, or abrasion. Replace only with replacement parts approved for your machine. See your John Deere dealer.

DX,ROPS1-19-22AUG13

Operating the Tractor Safely

You can reduce the risk of accidents by following these simple precautions:

- Use your tractor only for jobs it was designed to perform, for example, pushing, pulling, towing, actuating, and carrying a variety of interchangeable equipment designed to conduct agricultural work.
- Operators must be mentally and physically capable of accessing the operator's station and/or controls, and operating the machine properly and safely.
- Never operate machine when distracted, fatigued, or impaired. Proper machine operation requires the operator's full attention and awareness.
- This tractor is not intended to be used as a recreational vehicle.
- Read this operator's manual before operating the tractor and follow operating and safety instructions in the manual and on the tractor.
- Follow operation and ballasting instructions found in the operator's manual for your implements/ attachments, such as front loaders.
- Follow the instructions outlined in the operator's manual of any mounted or trailed machinery or trailer. Do not operate a combination of tractor-machine or tractor-trailer unless all instructions have been followed.
- Make sure that everyone is clear of machine, attached equipment, and work area before starting engine or operation.
- Stay clear of the three-point linkage and pickup hitch (if equipped) when controlling them.
- Keep hands, feet, and clothing away from power-driven parts.

Driving Concerns

- Never get on or off a moving tractor.
- Complete any required training prior to operating vehicle.
- Keep all children and nonessential personnel off tractors and all equipment.
- Never ride on a tractor unless seated on a John Deere approved seat with a seat belt.
- Keep all shields/guards in place.
- Use appropriate visual and audible signals when operating on public roads.
- Move to side of road before stopping.
- Reduce speed when turning, applying individual

brakes, or operating around hazards on rough ground or steep slopes.

- Stability degrades when attached implements are at high position.
- Couple brake pedals together for road travel.
- Pump brakes when stopping on slippery surfaces.
- Regularly clean fenders and fender valances (mud flaps) if installed. Remove dirt before driving on public roadways.

Heated and Ventilated Operator's Seat

- An overheated seat heater can cause a burn injury or damage to the seat. To reduce the risk of burns, use caution when using the seat heater for extended periods of time, especially if the operator cannot feel temperature change or pain to the skin. Do not place objects on the seat, such as a blanket, cushion, cover, or similar item, which can cause the seat heater to overheat.

Towing Loads

- Be careful when towing and stopping heavy loads. Stopping distance increases with speed and weight of towed loads, and on slopes. Towed loads with or without brakes that are too heavy for the tractor or are towed too fast can cause loss of control.
- Consider the total weight of the equipment and its load.
- Hitch towed loads only to approved couplings to avoid rearward upset.

Parking and Leaving the Tractor

- Before dismounting, shut off SCVs, disengage PTO, stop engine, lower implements/attachments to ground, place implement/attachment control devices in neutral, and securely engage park mechanism, including the park pawl and park brake. In addition, if the tractor is left unattended, remove key.
- Leaving transmission in gear with engine off will NOT prevent the tractor from moving.
- Never go near an operating PTO or an operating implement.
- Wait for all movement to stop before servicing machinery.

Common Accidents

Unsafe operation or misuse of the tractor can result in accidents. Be alert to hazards of tractor operation.

The most common accidents involving tractors are:

- Tractor rollover
- Collisions with motor vehicles
- Improper starting procedures
- Entanglement in PTO shafts
- Falling from tractor

- Crushing and pinching during hitching

DX,WW,TRACTOR-19-08MAY19

Avoid Backover Accidents



PC10857XW—UN—15APR13

Before moving machine, be sure that all persons are clear of machine path. Turn around and look directly for best visibility. Use a signal person when backing if view is obstructed or when in close quarters.

Do not rely on a camera to determine if personnel or obstacles are behind the machine. The system can be limited by many factors including maintenance practices, environmental conditions, and operating range.

DX,AVOID,BACKOVER,ACCIDENTS-19-30AUG10

Limited Use in Forestry Operation

The intended use of John Deere tractors when used in forestry operations is limited to tractor-specific applications like transport, stationary work such as log splitting, propulsion, or operating implements with PTO, hydraulic, or electrical systems.

These are applications where normal operation does not present a risk of falling or penetrating objects. Any forestry applications beyond these applications, such as forwarding and loading, requires fitment of application-specific components including Falling Object Protective Structure (FOPS) and/or Operative Protective Structures (OPS). Contact John Deere dealer for special components.

DX,WW,FORESTRY-19-12OCT11

Operating the Loader Tractor Safely

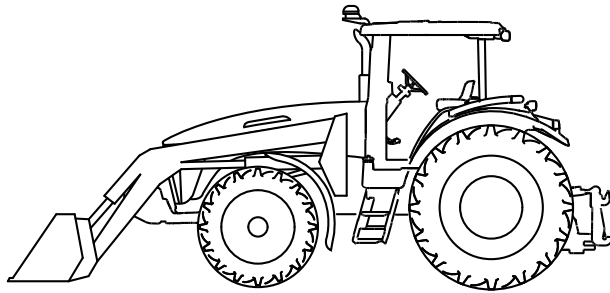

TS1692—UN—09NOV09

When operating a machine with a loader application, reduce speed as required to ensure good tractor and loader stability.

To avoid tractor rollover and damage to front tires and tractor, do not carry load with your loader at a speed over 10 km/h (6 mph).

To avoid tractor damage do not use a front loader or a sprayer tank if the tractor is equipped with a 3 Meter Front Axle.

Never allow anyone to walk or work under a raised loader.

Do not use loader as a work platform.

Do not lift or carry anyone on loader, in bucket, or on implement or attachment.

Lower loader to ground before leaving operators station.

The Rollover Protective Structure (ROPS) or cab roof, if equipped, may not provide sufficient protection from load falling onto the operators station. To prevent loads from falling onto the operators station, always use appropriate implements for specific applications (that is, manure forks, round bale forks, round bale grippers, and claspers).

Ballast tractor in accordance to Ballast Recommendations in PREPARE TRACTOR section.

DX,WW,LOADER-19-18SEP12

Keep Riders Off Machine

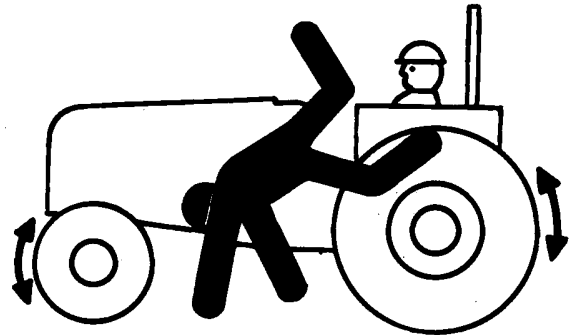

TS290—UN—23AUG88

Only allow the operator on the machine. Keep riders off.

Riders on machine are subject to injury such as being struck by foreign objects and being thrown off of the machine. Riders also obstruct the operator's view resulting in the machine being operated in an unsafe manner.

DX,RIDER-19-03MAR93

Instructional Seat



TS1730—UN—24MAY13

The instructional seat, if so equipped, has been provided only for training operators or diagnosing machine problems.

DX,SEAT,NA-19-22AUG13

Use Safety Lights and Devices

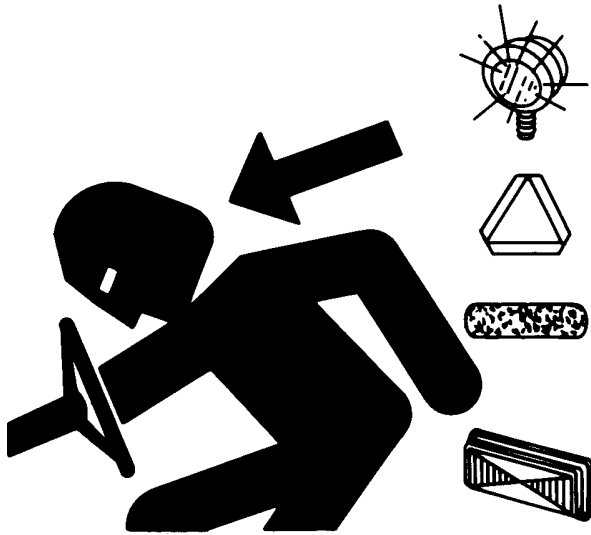

TS951—UN—12APR90

Prevent collisions between other road users, slow moving tractors with attachments or towed equipment, and self-propelled machines on public roads. Frequently check for traffic from the rear, especially in turns, and use turn signal lights.

Use headlights, flashing warning lights, and turn signals day and night. Follow local regulations for equipment lighting and marking. Keep lighting and marking visible, clean, and in good working order. Replace or repair lighting and marking that has been damaged or lost. An implement safety lighting kit is available from your John Deere dealer.

DX.FLASH-19-07JUL99

Transport Towed Equipment at Safe Speeds

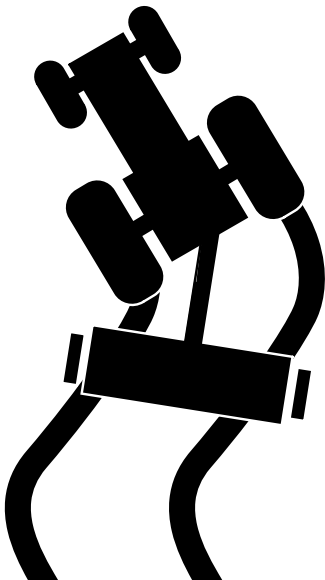

TS1686—UN—27SEP06

Do not exceed the maximum transport speed. This towing unit may be capable of operating at transport speeds that exceed the maximum allowable transport speed for towed implements.

Before transporting a towed implement, determine from signs on the implement or information provided in the implement's operator manual the maximum transport speed. Never transport at speeds that exceed the implement's maximum transport speed. Exceeding the implement's maximum transport speed can result in:

- Loss of control of the towing unit/implement combination
- Reduced or no ability to stop during braking
- Implement tire failure
- Damage to the implement structure or its components

Implements shall be equipped with brakes if the maximum fully loaded weight is greater than 1500 kg (3307 lbs) and greater than 1.5 times the weight of the towing unit.

Example: Implement mass is 1600 kg (3527 lbs) and towing unit mass is 1600 kg (3527 lbs), example implement is not required to have brakes.

Implements without brakes: Do not transport at speeds greater than 32 km/h (20 mph).

Implements with brakes:

- If the manufacturer does not specify a maximum transport speed, do not tow at speeds greater than 40 km/h (25 mph).
- When transporting at speeds up to 40 km/h (25 mph) the fully loaded implement must weigh less than 4.5 times the towing unit weight.
- When transporting at speeds between 40—50 km/h (25—31 mph) the fully loaded implement must weigh less than 3.0 times the towing unit weight.

When towing a trailer, become familiar with the braking characteristics and ensure the compatibility of the tractor/trailer combination in regard to the deceleration rate.

DX.TOW1-19-28FEB17

Use Caution on Slopes, Uneven Terrain, and Rough Ground

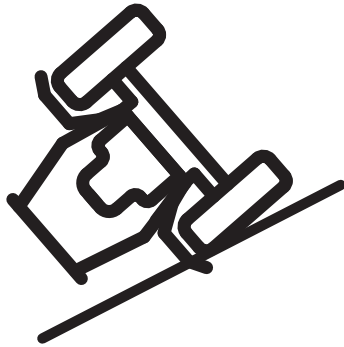

RXA0103437—UN—01JUL09

Avoid holes, ditches, and obstructions which cause the tractor to tip, especially on slopes. Avoid sharp uphill turns.

Driving forward out of a ditch, mired condition, or up a steep slope could cause the tractor to tip over rearward. Back out of these situations if possible.

Danger of overturn increases greatly with narrow tread setting, at high speed.

Not all conditions that can cause a tractor to overturn are listed. Be alert for any situation in which stability may be compromised.

Slopes are a major factor related to loss-of-control and tip-over accidents, which can result in severe injury or death. Operation on all slopes requires extra caution.

Uneven terrain or rough ground can cause loss-of-control and tip-over accidents, which can result in severe injury or death. Operation on uneven terrain or rough ground requires extra caution.

Never drive near the edge of a gully, drop-off, ditch, steep embankment, or a body of water. The machine could suddenly roll over if a wheel goes over the edge or the ground caves in.

Choose a low ground speed so you will not have to stop or shift while on a slope.

Avoid starting, stopping, or turning on a slope. If the tires lose traction, disengage the PTO and proceed slowly, straight down the slope.

Keep all movement on slopes slow and gradual. Do not make sudden changes in speed or direction, which could cause the machine to roll over.

DX,WW,SLOPE-19-28FEB17

Freeing a Mired Machine

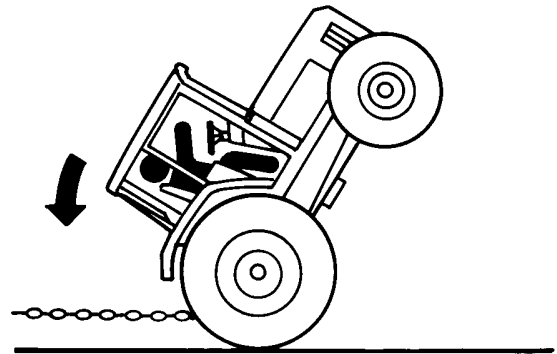

TS1645—UN—15SEP95



TS263—UN—23AUG88

Attempting to free a mired machine can involve safety hazards such as the mired tractor tipping rearward, the towing tractor overturning, and the tow chain or tow bar (a cable is not recommended) failing and recoiling from its stretched condition.

Back your tractor out if it gets mired down in mud. Unhitch any towed implements. Dig mud from behind the rear wheels. Place boards behind the wheels to provide a solid base and try to back out slowly. If necessary, dig mud from the front of all wheels and drive slowly ahead.

If necessary to tow with another unit, use a tow bar or a long chain (a cable is not recommended). Inspect the chain for flaws. Make sure all parts of towing devices are of adequate size and strong enough to handle the load.

Always hitch to the drawbar of the towing unit. Do not hitch to the front pushbar attachment point. Before moving, clear the area of people. Apply power smoothly to take up the slack: a sudden pull could snap any towing device causing it to whip or recoil dangerously.

DX,MIREDD-19-07JUL99

Avoid Contact with Agricultural Chemicals

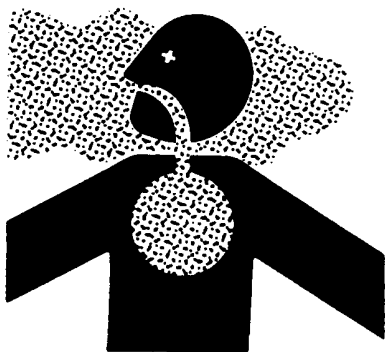

TS220—UN—15APR13



TS272—UN—23AUG88

This enclosed cab does not protect against inhaling vapor, aerosol or dust. If pesticide use instructions require respiratory protection, wear an appropriate respirator inside the cab.

Before leaving the cab, wear personal protective equipment as required by the pesticide use instructions. When re-entering the cab, remove protective equipment and store either outside the cab in a closed box or some other type of sealable container or inside the cab in a pesticide resistant container, such as a plastic bag.

Clean your shoes or boots to remove soil or other contaminated particles prior to entering the cab.

DX,CABS-19-25MAR09

Handle Agricultural Chemicals Safely

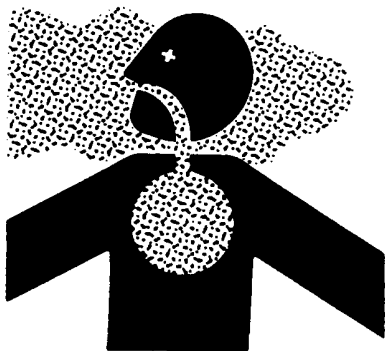

TS220—UN—15APR13

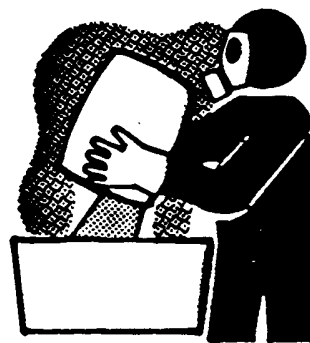

A34471

A34471—UN—11OCT88

Chemicals used in agricultural applications such as fungicides, herbicides, insecticides, pesticides, rodenticides, and fertilizers can be harmful to your health or the environment if not used carefully.

Always follow all label directions for effective, safe, and legal use of agricultural chemicals.

Reduce risk of exposure and injury:

- Wear appropriate personal protective equipment as recommended by the manufacturer. In the absence of manufacturer's instructions, follow these general guidelines:
 - Chemicals labeled '**Danger**': Most toxic. Generally require use of goggles, respirator, gloves, and skin protection.
 - Chemicals labeled '**Warning**': Less toxic. Generally require use of goggles, gloves, and skin protections.
 - Chemicals labeled '**Caution**': Least toxic. Generally require use of gloves and skin protection.
- Avoid inhaling vapor, aerosol or dust.
- Always have soap, water, and towel available when working with chemicals. If chemical contacts skin, hands, or face, wash immediately with soap and water. If chemical gets into eyes, flush immediately with water.
- Wash hands and face after using chemicals and before eating, drinking, smoking, or urination.
- Do not smoke or eat while applying chemicals.
- After handling chemicals, always bathe or shower and change clothes. Wash clothing before wearing again.
- Seek medical attention immediately if illness occurs during or shortly after use of chemicals.
- Keep chemicals in original containers. Do not transfer chemicals to unmarked containers or to containers used for food or drink.
- Store chemicals in a secure, locked area away from human or livestock food. Keep children away.
- Always dispose of containers properly. Triple rinse

empty containers and puncture or crush containers and dispose of properly.

DX,WW,CHEM01-19-24AUG10

Handling Batteries Safely



TS204—UN—15APR13

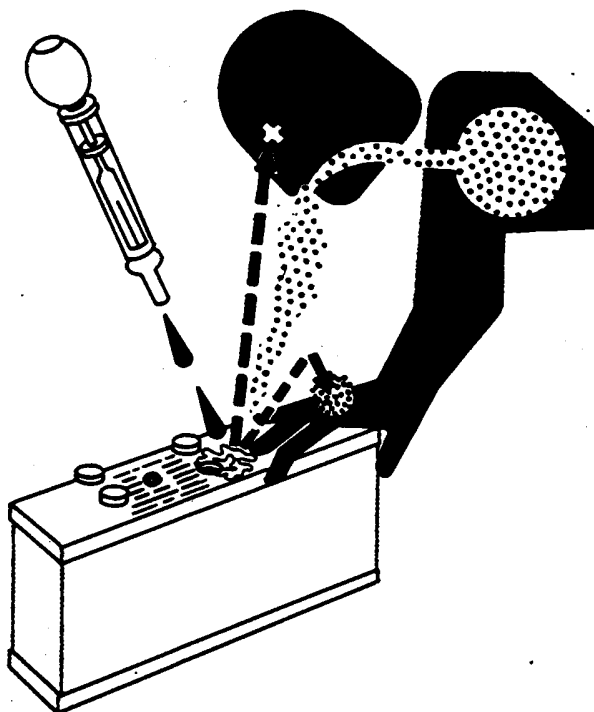

TS203—UN—23AUG88

Battery gas can explode. Keep sparks and flames away from batteries. Use a flashlight to check battery electrolyte level.

Never check battery charge by placing a metal object across the posts. Use a voltmeter or hydrometer.

Always remove grounded (-) battery clamp first and replace grounded clamp last.

Sulfuric acid in battery electrolyte is poisonous and

strong enough to burn skin, eat holes in clothing, and cause blindness if splashed into eyes.

Avoid hazards by:

- Filling batteries in a well-ventilated area
- Wearing eye protection and rubber gloves
- Avoiding use of air pressure to clean batteries
- Avoiding breathing fumes when electrolyte is added
- Avoiding spilling or dripping electrolyte
- Using correct battery booster or charger procedure.

If acid is spilled on skin or in eyes:

1. Flush skin with water.
2. Apply baking soda or lime to help neutralize the acid.
3. Flush eyes with water for 15—30 minutes. Get medical attention immediately.

If acid is swallowed:

1. Do not induce vomiting.
2. Drink large amounts of water or milk, but do not exceed 2 L (2 qt.).
3. Get medical attention immediately.

WARNING: Battery posts, terminals, and related accessories contain lead and lead compounds, chemicals known to the State of California to cause cancer and reproductive harm. **Wash hands after handling.**

DX,WW,BATTERIES-19-02DEC10

Avoid Heating Near Pressurized Fluid Lines



TS953—UN—15MAY90

Flammable spray can be generated by heating near pressurized fluid lines, resulting in severe burns to yourself and bystanders. Do not heat by welding, soldering, or using a torch near pressurized fluid lines or other flammable materials. Pressurized lines can accidentally burst when heat goes beyond the immediate flame area.

DX,TORCH-19-10DEC04

Remove Paint Before Welding or Heating

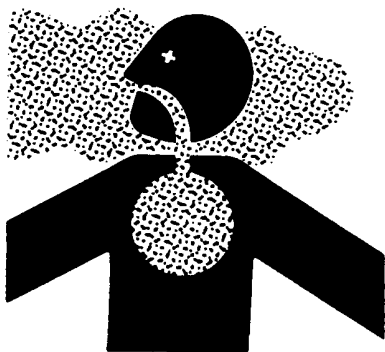

TS220—UN—15APR13

Avoid potentially toxic fumes and dust.

Hazardous fumes can be generated when paint is heated by welding, soldering, or using a torch.

Remove paint before heating:

- Remove paint a minimum of 100 mm (4 in.) from area to be affected by heating. If paint cannot be removed, wear an approved respirator before heating or welding.
- If you sand or grind paint, avoid breathing the dust. Wear an approved respirator.
- If you use solvent or paint stripper, remove stripper with soap and water before welding. Remove solvent or paint stripper containers and other flammable material from area. Allow fumes to disperse at least 15 minutes before welding or heating.

Do not use a chlorinated solvent in areas where welding will take place.

Do all work in an area that is well ventilated to carry toxic fumes and dust away.

Dispose of paint and solvent properly.

DX,PAINT-19-24JUL02

Handle Electronic Components and Brackets Safely



TS249—UN—23AUG88

Falling while installing or removing electronic

components mounted on equipment can cause serious injury. Use a ladder or platform to easily reach each mounting location. Use sturdy and secure footholds and handholds. Do not install or remove components in wet or icy conditions.

If installing or servicing a RTK base station on a tower or other tall structure, use a certified climber.

If installing or servicing a global positioning receiver mast used on an implement, use proper lifting techniques and wear proper protective equipment. The mast is heavy and can be awkward to handle. Two people are required when mounting locations are not accessible from the ground or from a service platform.

DX,WW,RECEIVER-19-24AUG10

Practice Safe Maintenance



TS218—UN—23AUG88

Understand service procedure before doing work. Keep area clean and dry.

Never lubricate, service, or adjust machine while it is moving. Keep hands, feet, and clothing away from power-driven parts. Disengage all power and operate controls to relieve pressure. Lower equipment to the ground. Stop the engine. Remove the key. Allow machine to cool.

Securely support any machine elements that must be raised for service work.

Keep all parts in good condition and properly installed.

Fix damage immediately. Replace worn or broken parts. Remove any buildup of grease, oil, or debris.

On self-propelled equipment, disconnect battery ground cable (-) before making adjustments on electrical systems or welding on machine.

On towed implements, disconnect wiring harnesses from tractor before servicing electrical system components or welding on machine.

Falling while cleaning or working at height can cause serious injury. Use a ladder or platform to easily reach each location. Use sturdy and secure footholds and handholds.

DX,SERV-19-28FEB17

Avoid Hot Exhaust



RG17488—UN—21AUG09

Servicing machine or attachments with engine running can result in serious personal injury. Avoid exposure and skin contact with hot exhaust gases and components.

Exhaust parts and streams become very hot during operation. Exhaust gases and components reach temperatures hot enough to burn people, ignite, or melt common materials.

DX,EXHAUST-19-20AUG09

Clean Exhaust Filter Safely



TS227—UN—15APR13

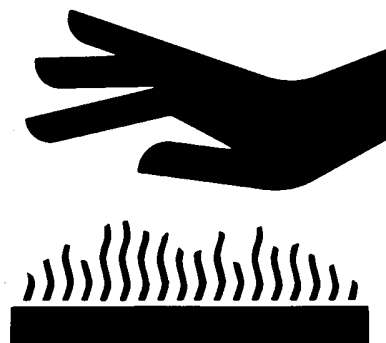

TS271—UN—23AUG88

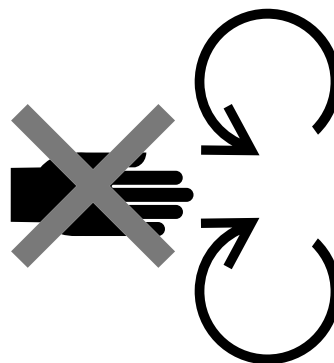

TS1693—UN—09DEC09



TS1695—UN—07DEC09

During exhaust filter cleaning operations, the engine may run at elevated idle and hot temperatures for an extended period of time. Exhaust gases and exhaust filter components reach temperatures hot enough to burn people, or ignite or melt common materials.

Keep machine away from people, animals, or structures which may be susceptible to harm or damage from hot exhaust gases or components. Avoid potential fire or explosion hazards from flammable materials and vapors near the exhaust. Keep exhaust outlet away from people and anything that can melt, burn, or explode.

Closely monitor machine and surrounding area for smoldering debris during and after exhaust filter cleaning.

Adding fuel while an engine is running can create a fire or explosion hazard. Always stop engine before refueling machine and clean up any spilled fuel.

Always make sure that engine is stopped while hauling machine on a truck or trailer.

Contact with exhaust components while still hot can result in serious personal injury.

Avoid contact with these components until cooled to safe temperatures.

If service procedure requires engine to be running:

- Only engage power-driven parts required by service procedure
- Ensure that other people are clear of operator station and machine

Keep hands, feet, and clothing away from power-driven parts.

Always disable movement (neutral), set the parking brake or mechanism and disconnect power to attachments or tools before leaving the operator's station.

Shut off engine and remove key (if equipped) before leaving the machine unattended.

DX,EXHAUST,FILTER-19-12JAN11

Work In Ventilated Area

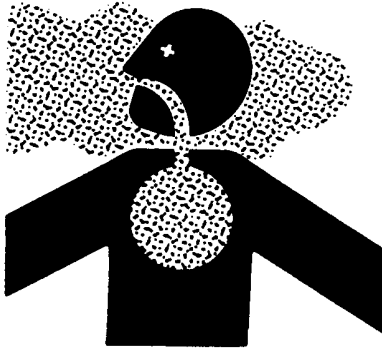

TS220—UN—15APR13

Engine exhaust fumes can cause sickness or death. If it is necessary to run an engine in an enclosed area, remove the exhaust fumes from the area with an exhaust pipe extension.

If you do not have an exhaust pipe extension, open the doors and get outside air into the area.

DX,AIR-19-17FEB99

Support Machine Properly

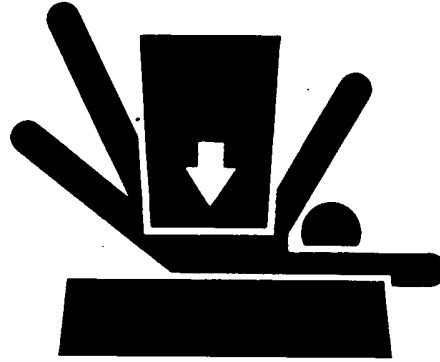

TS229—UN—23AUG88

Always lower the attachment or implement to the ground before you work on the machine. If the work requires that the machine or attachment be lifted, provide secure support for them. If left in a raised position, hydraulically supported devices can settle or leak down.

Do not support the machine on cinder blocks, hollow tiles, or props that may crumble under continuous load. Do not work under a machine that is supported solely by a jack. Follow recommended procedures in this manual.

When implements or attachments are used with a machine, always follow safety precautions listed in the implement or attachment operator's manual.

DX,LOWER-19-24FEB00

Prevent Machine Runaway

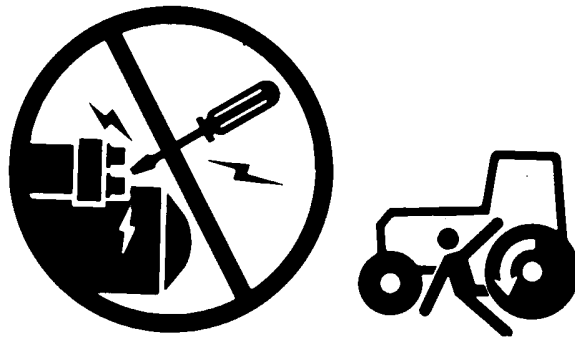

TS177—UN—11JAN89

Avoid possible injury or death from machinery runaway.

Do not start engine by shorting across starter terminals. Machine will start in gear if normal circuitry is bypassed.

NEVER start engine while standing on ground. Start engine only from operator's seat, with transmission in neutral or park.

DX,BYPAS1-19-29SEP98

Park Machine Safely

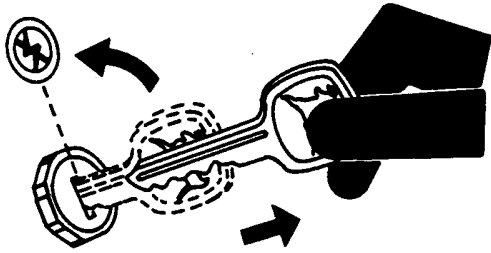

TS230—UN—24MAY89

Before working on the machine:

- Lower all equipment to the ground.
- Stop the engine and remove the key.
- Disconnect the battery ground strap.
- Hang a "DO NOT OPERATE" tag in operator station.

DX,PARK-19-04JUN90

Service Cooling System Safely

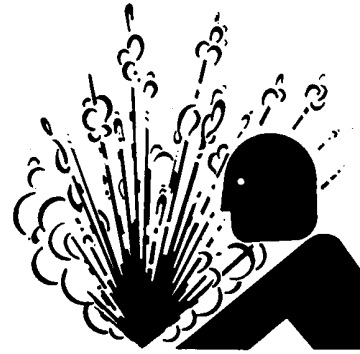

TS281—UN—15APR13

Explosive release of fluids from pressurized cooling system can cause serious burns.

Shut off engine. Only remove filler cap when cool enough to touch with bare hands. Slowly loosen cap to first stop to relieve pressure before removing completely.

DX,WW,COOLING-19-19AUG09

Transport Tractor Safely

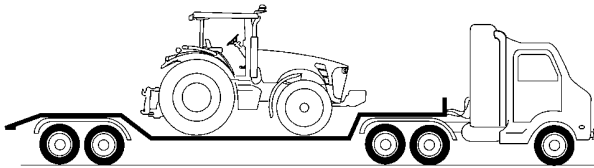

RXA0103709—UN—01JUL09

A disabled tractor is best transported on a flatbed carrier. Use chains to secure the tractor to the carrier. The axles and tractor frame are suitable attachment points.

Before transporting the tractor on a low-loader truck or flatbed rail wagon, make sure that the hood is secured over the tractor engine and that doors, roof hatch (if equipped) and windows are properly closed.

Never tow a tractor at a speed greater than 10 km/h (6 mph). An operator must steer and brake the tractor under tow.

DX,WW,TRANSPORT-19-19AUG09

Service Accumulator Systems Safely

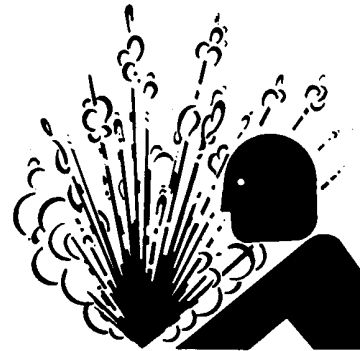

TS281—UN—15APR13

Escaping fluid or gas from systems with pressurized accumulators that are used in air conditioning, hydraulic, and air brake systems can cause serious injury. Extreme heat can cause the accumulator to burst, and pressurized lines can be accidentally cut. Do not weld or use a torch near a pressurized accumulator or pressurized line.

Relieve pressure from the pressurized system before removing accumulator.

Relieve pressure from the hydraulic system before removing accumulator. Never attempt to relieve hydraulic system or accumulator pressure by loosening a fitting.

Accumulators cannot be repaired.

DX,WW,ACCLA2-19-22AUG03

Service Tires Safely



RXA0103438—UN—11JUN09

Explosive separation of a tire and rim parts can cause serious injury or death.

Do not attempt to mount a tire unless you have the proper equipment and experience to perform the job.

Always maintain the correct tire pressure. Do not inflate the tires above the recommended pressure. Never weld or heat a wheel and tire assembly. The heat can cause an increase in air pressure resulting in a tire explosion. Welding can structurally weaken or deform the wheel.

When inflating tires, use a clip-on chuck and extension hose long enough to allow you to stand to one side and NOT in front of or over the tire assembly. Use a safety cage if available.

Check wheels for low pressure, cuts, bubbles, damaged rims, or missing lug bolts and nuts.

Wheels and tires are heavy. When handling wheels and tires use a safe lifting device or get an assistant to help lift, install, or remove.

DX,WW,RIMS-19-28FEB17

Service Front-Wheel Drive Tractor Safely

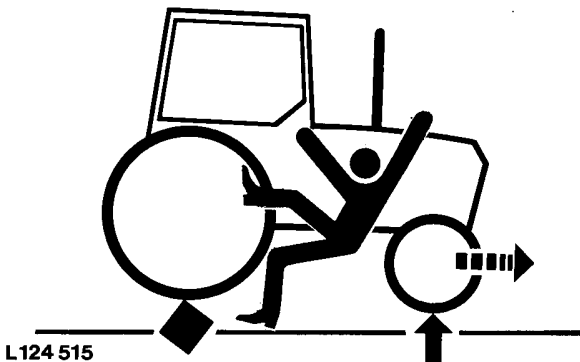

L124 515

L124515—UN—06AUG94

When servicing front-wheel drive tractor with the rear wheels supported off the ground and rotating wheels by engine power, always support front wheels in a similar manner. Loss of electrical power or transmission hydraulic system pressure will engage the front driving wheels, pulling the rear wheels off the support if front

wheels are not raised. Under these conditions, front drive wheels can engage even with switch in disengaged position.

DX,WW,MFWD-19-19AUG09

Tightening Wheel Retaining Bolts/Nuts

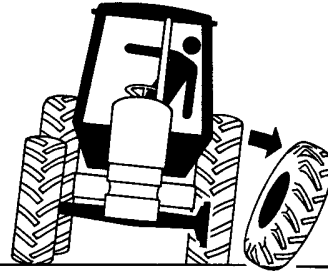

L124 516

L124516—UN—03JAN95

Torque wheel retaining bolts/nuts at the intervals specified in section Break-In Period and Service.

DX,WW,WHEEL-19-12OCT11

Avoid High-Pressure Fluids

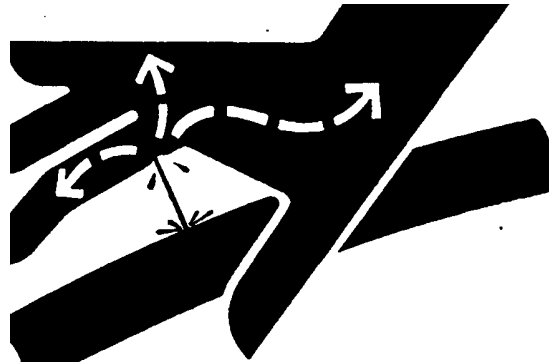

X9811—UN—23AUG88

Inspect hydraulic hoses periodically – at least once per year – for leakage, kinking, cuts, cracks, abrasion, blisters, corrosion, exposed wire braid or any other signs of wear or damage.

Replace worn or damaged hose assemblies immediately with John Deere approved replacement parts.

Escaping fluid under pressure can penetrate the skin causing serious injury.

Avoid the hazard by relieving pressure before disconnecting hydraulic or other lines. Tighten all connections before applying pressure.

Search for leaks with a piece of cardboard. Protect hands and body from high-pressure fluids.

If an accident occurs, see a doctor immediately. Any

fluid injected into the skin must be surgically removed within a few hours or gangrene may result. Doctors unfamiliar with this type of injury should reference a knowledgeable medical source. Such information is available in English from Deere & Company Medical Department in Moline, Illinois, U.S.A., by calling 1-800-822-8262 or +1 309-748-5636.

DX,FLUID-19-12OCT11

Do Not Open High-Pressure Fuel System



TS1343—UN—18MAR92

High-pressure fluid remaining in fuel lines can cause serious injury. Do not disconnect or attempt repair of fuel lines, sensors, or any other components between the high-pressure fuel pump and nozzles on engines with High Pressure Common Rail (HPCR) fuel system.

Only technicians familiar with this type of system can perform repairs. (See your John Deere dealer.)

DX,WW,HPCR1-19-07JAN03

Store Attachments Safely



TS219—UN—23AUG88

Stored attachments such as dual wheels, cage wheels, and loaders can fall and cause serious injury or death.

Securely store attachments and implements to prevent falling. Keep playing children and bystanders away from storage area.

DX,STORE-19-03MAR93

Decommissioning — Proper Recycling and Disposal of Fluids and Components

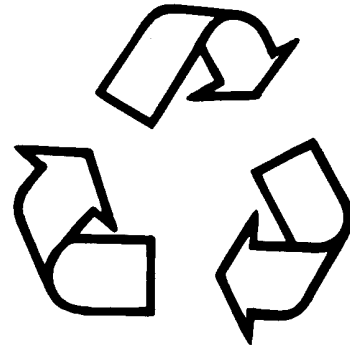

TS1133—UN—15APR13

Safety and environmental stewardship measures must be taken into account when decommissioning a machine and/or component. These measures include the following:

- Use appropriate tools and personal protective equipment such as clothing, gloves, face shields or glasses, during the removal or handling of objects and materials.
- Follow instructions for specialized components.
- Release stored energy by lowering suspended machine elements, relaxing springs, disconnecting the battery or other electrical power, and releasing pressure in hydraulic components, accumulators, and other similar systems.
- Minimize exposure to components which may have residue from agricultural chemicals, such as fertilizers and pesticides. Handle and dispose of these components appropriately.
- Carefully drain engines, fuel tanks, radiators, hydraulic cylinders, reservoirs, and lines before recycling components. Use leak-proof containers when draining fluids. Do not use food or beverage containers.
- Do not pour waste fluids onto the ground, down a drain, or into any water source.
- Observe all national, state, and local laws, regulations, or ordinances governing the handling or disposal of waste fluids (example: oil, fuel, coolant, brake fluid); filters; batteries; and, other substances or parts. Burning of flammable fluids or components in other than specially designed incinerators may be prohibited by law and could result in exposure to harmful fumes or ashes.
- Service and dispose of air conditioning systems appropriately. Government regulations may require a certified service center to recover and recycle air conditioning refrigerants which could damage the atmosphere if allowed to escape.
- Evaluate recycling options for tires, metal, plastic, glass, rubber, and electronic components which may be recyclable, in part or completely.

Safety

- Contact your local environmental or recycling center, or your John Deere dealer for information on the proper way to recycle or dispose of waste.

DX,DRAIN-19-01JUN15

Safety Signs

Replace Safety Signs

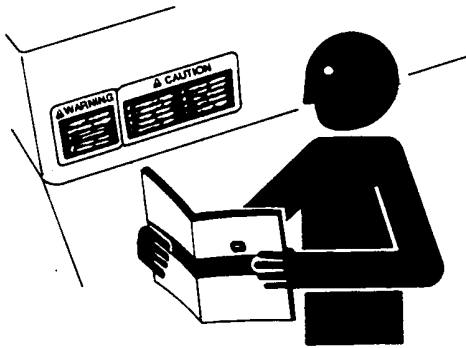

TS201—UN—15APR13

Replace missing or damaged safety signs. Use this operator's manual for correct safety sign placement.

There can be additional safety information contained on parts and components sourced from suppliers that is not reproduced in this operator's manual.

DX,SIGNS-19-18AUG09

ROPS in Normal Position, Riders, and Operator's Manual



LV28433—UN—18MAY17



LV29468—UN—02OCT17

RH Fender

- If this machine is equipped with a foldable roll-over protective structure (ROPS), keep the ROPS in the fully extended and locked position. **USE** a seat belt when you operate with a ROPS in the fully extended position.
 - Hold the latch and pull the seat belt across the body.
 - Insert the latch into the buckle. Listen for a click.
 - Tug on the seat belt latch to make sure the belt is securely fastened.
 - Snug the seat belt across the hips.
- If this machine is operated with the ROPS folded (e.g., to enter a low building), drive with extreme caution. **DO NOT USE** a seat belt with the ROPS folded.
- Return the ROPS to the raised, fully extended position as soon as the machine is operated under normal conditions.

CAUTION: Avoid falling and being struck.

Keep riders off. Riders on machine are subject to injury such as being struck by foreign objects and being thrown off of the machine. Riders also obstruct the operator's view resulting in the machine being operated in an unsafe manner.

CAUTION: Avoid the risk of injury.

This Operator's Manual contains important information necessary for safe machine operation and explanation of safety signs. Carefully observe all safety rules to avoid accidents.

PP71895,0001570-19-26AUG20

Folding ROPS

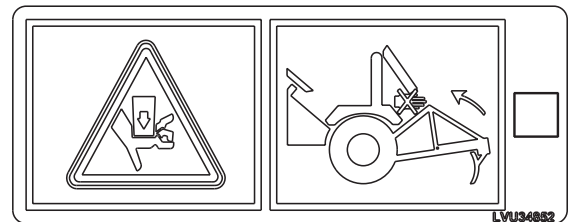

LV29144—UN—15AUG17

CAUTION: Avoid crushing injury or death during rollover.

Use Foldable ROPS and Seat Belt Properly.

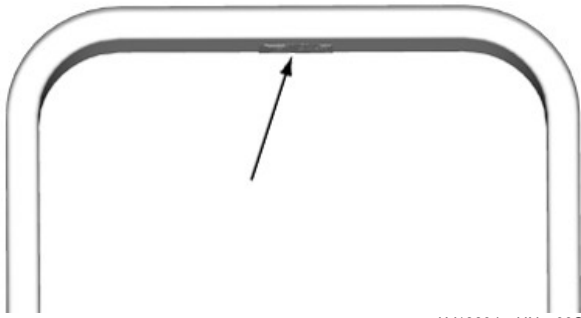

LV18894—UN—03SEP13

CAUTION: Avoid amputation.

Hands or fingers may be pinched between folded ROPS and rear implements. Do not place hands or fingers near foldable ROPS when implements are raised.

PP71895,0001571-19-25AUG20

Use Foldable ROPS and Seat Belt Properly

CAUTION: Avoid crushing injury or death during rollover.

- If this machine is equipped with a roll-over protective structure (ROPS). **USE** a seat belt when you operate with a ROPS.
 - Hold the latch and pull the seat belt across the body.
 - Insert the latch into the buckle. Listen for a click.
 - Tug on the seat belt latch to make sure the belt is securely fastened.
 - Snug the seat belt across the hips.
- If this machine is operated with the ROPS folded (e.g., to enter a low building), drive with extreme caution. **DO NOT USE** a seat belt with the ROPS folded.
- Return the ROPS to the raised, fully extended position as soon as the machine is operated under normal conditions.

PP71895,0001572-19-25AUG20

Use Seat Belt

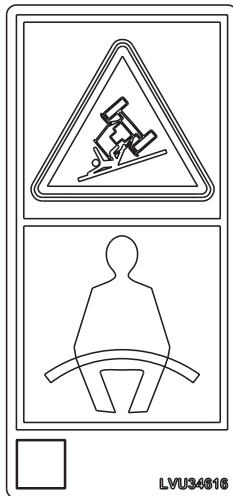

LVU34816

LV28494—UN—18MAY17



RH Side of Rops

LV21793—UN—05MAY14

Noise



LV29391—UN—08SEP17

(For specific region requirements)

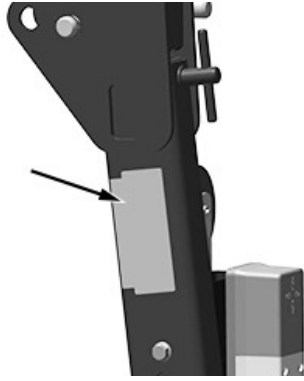

Left side ROPS

LV29465—UN—02OCT17

CAUTION: Avoid hearing damage.

Prolonged exposure to loud noise can cause impairment or loss of hearing. Wear suitable hearing protection.

PP71895,0001573-19-25AUG20

Controls and Instruments

Front Console Controls



LV30674—UN—11NOV19

Front Console

A—Key Switch
B—Turn Signal Switch
C—Instrument Cluster

D—Engine Speed Hand Throttle
E—Horn

UP00731,00009E7-19-06NOV19

Foot-Operated Controls

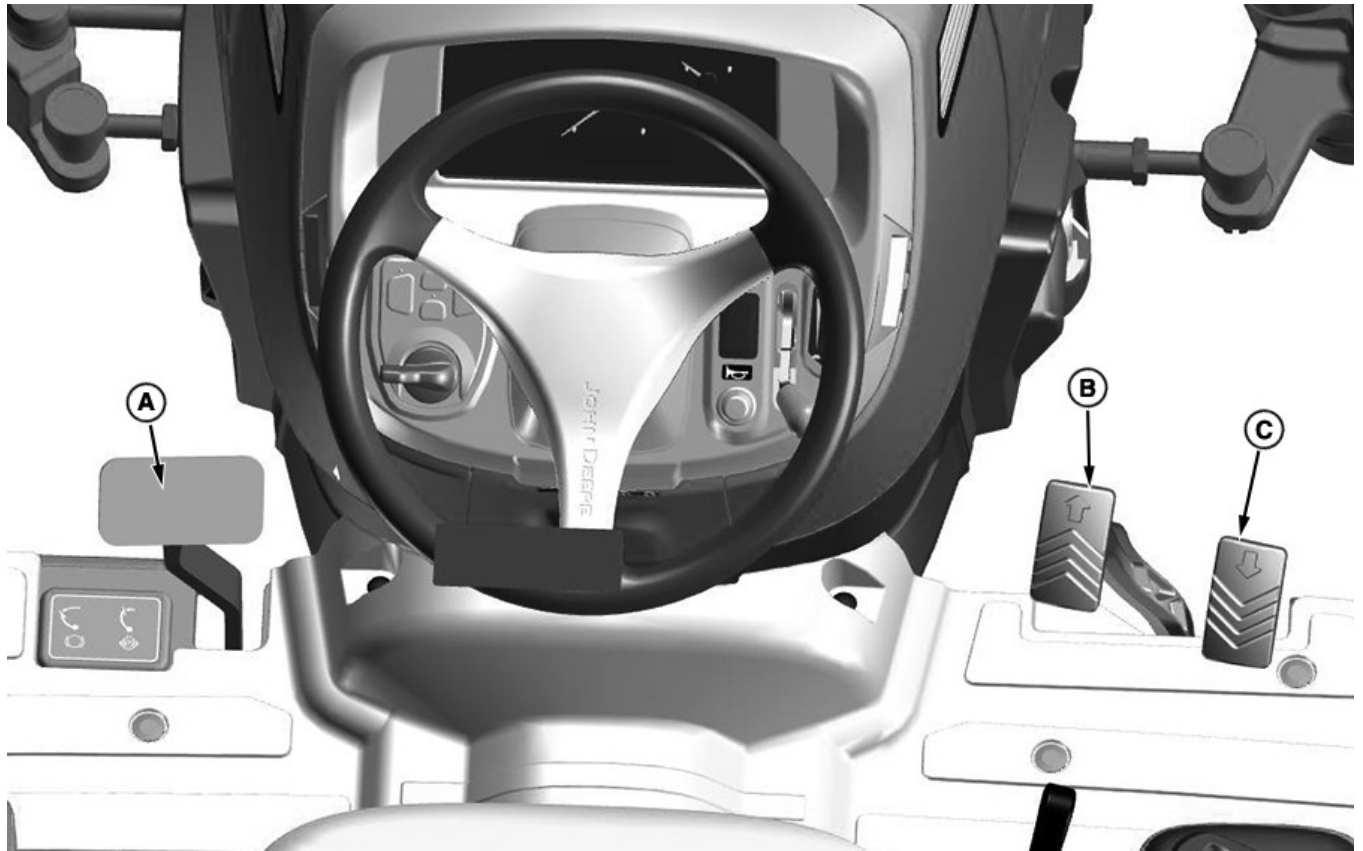

LV30675—UN—07NOV19

Foot Controls

A—Brake / Differential Lock Pedal
B—Forward Travel Pedal

C—Reverse Travel Pedal

UP00731,00009EE-19-07NOV19

Right-Hand Console Controls

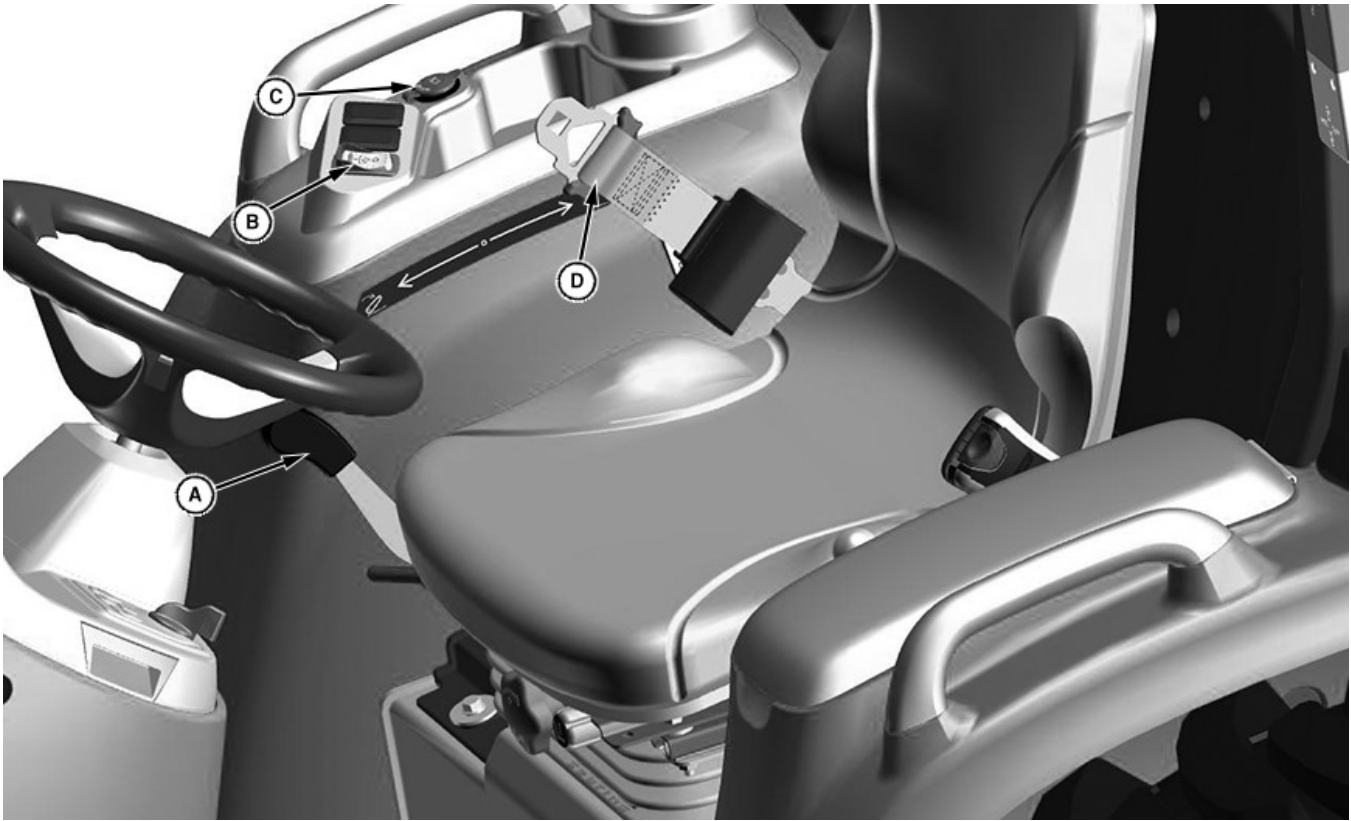

LV29072—UN—03OCT17

Right-Hand Side Console

A—Rockshaft Control Lever
B—Power Take Off Switch

C—12 V Outlet
D—Seat Belt

UP00731,00003E5-19-03OCT17

Left-Hand Console Controls

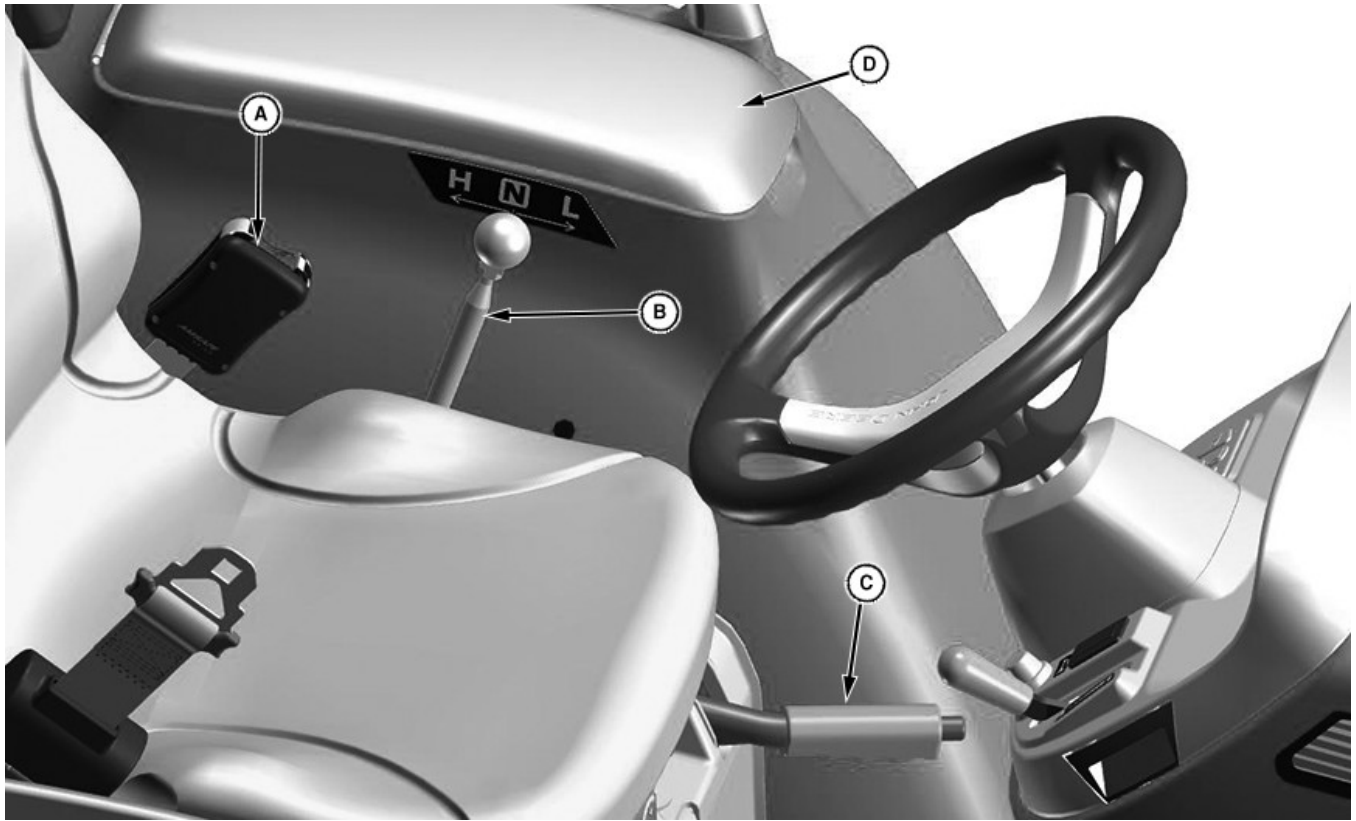

LV29073—UN—16AUG17

Left-Hand Side Console

A—Seat Belt
B—Transmission Range Shift Lever

C—Park Brake
D—Operator Manual Holder

UP00731,00003E6-19-10AUG17

MFWD, Rate-of-Drop, and Seat Controls

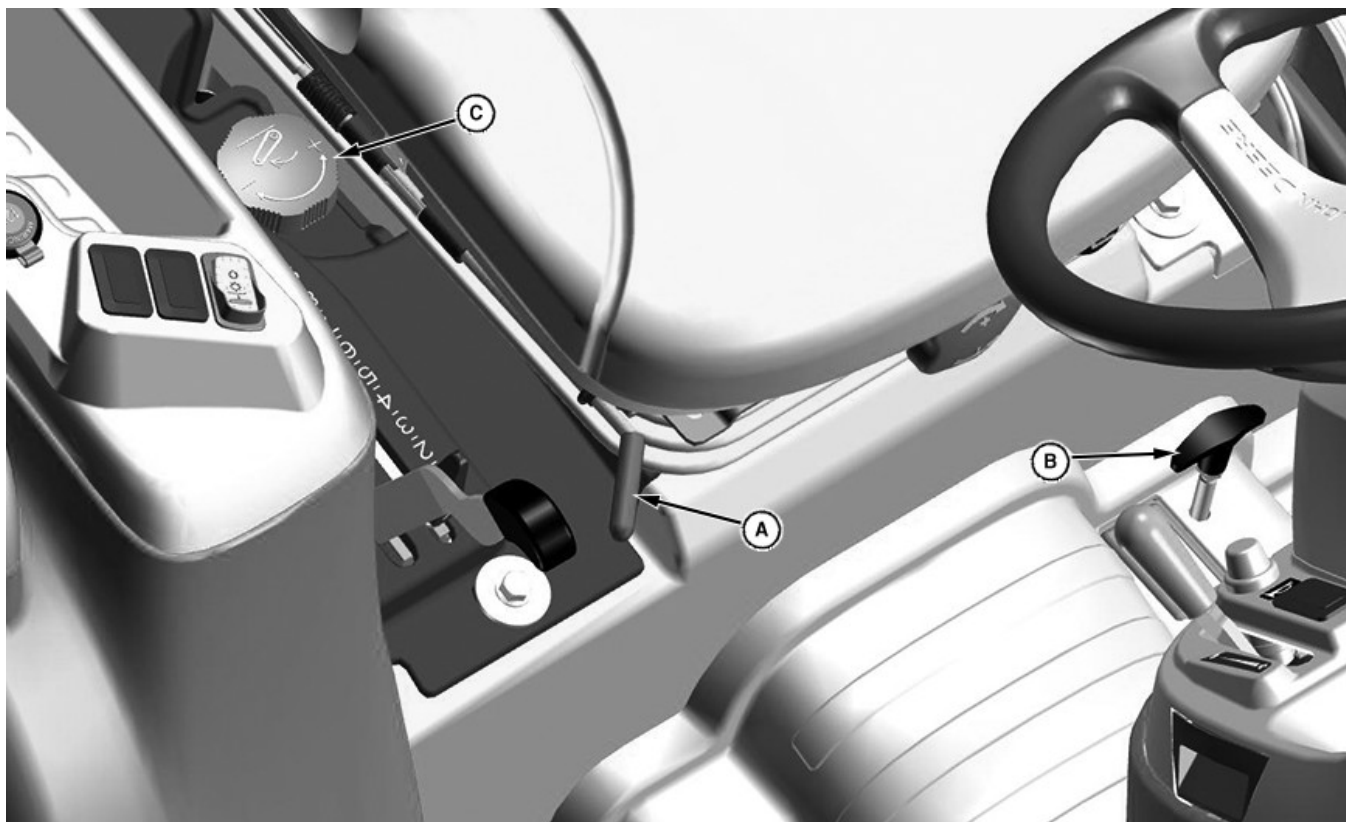

LV29074—UN—16AUG17

MFWD Control Lever, and Seat Adjustment Lever

A—Seat Adjustment Lever
B—MFWD Control Lever

C—Rate-of-Drop/Lock Valve Knob

UP00731.00003E7-19-26JAN18

Instrument Cluster

Instrument Control Panel

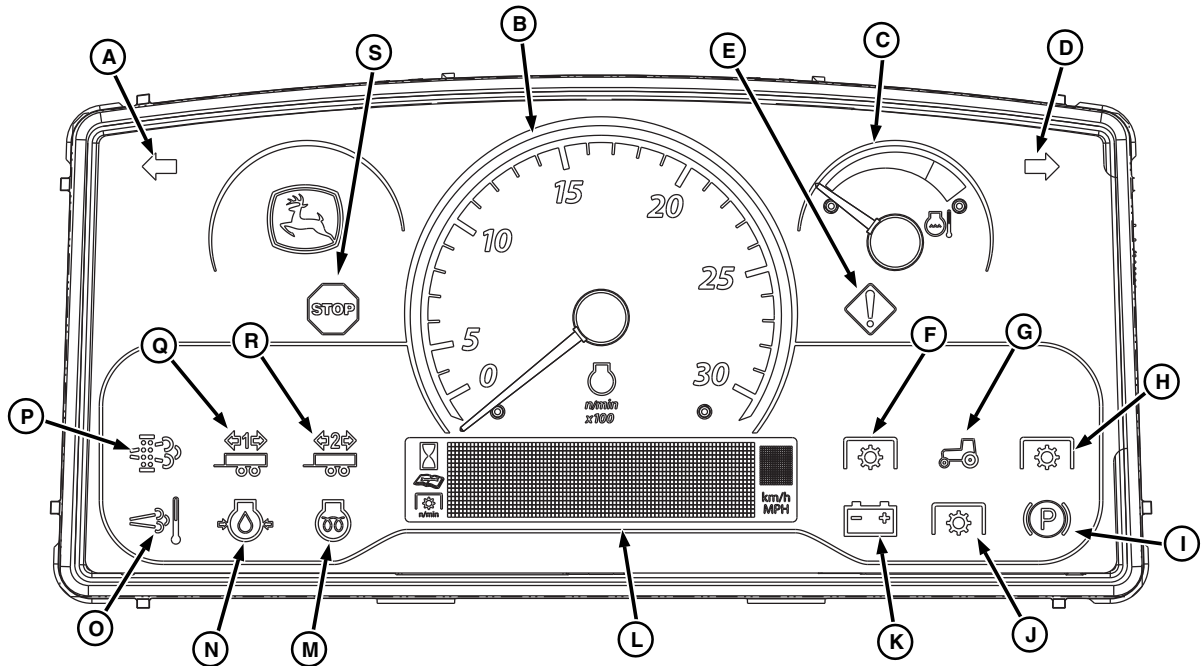

Instrument Control Panel

LV30664—UN—11FEB20

A - Left Turn Signal/Warning Flasher Indicator Light - Left turn signal, hazard light, and the headlight/taillight ON indicator light.

B - Tachometer - Displays engine speed in increments of 100.

C - Engine Coolant Temperature Gauge - Indicates temperature of the cooling system.

D - Right Turn Signal/Warning Flasher Indicator Light - Right turn signal, hazard light, and the headlight/taillight ON indicator light.

E - Service Alert Indicator - Light flashes indicating performance or operational problem is detected that needs to be resolved as soon as possible.

F - Not Used

G - Not Used

H - Not Used

I - Parking Brake Light - Illuminates when ignition key is in ON position and the park brake is engaged.

J - PTO Indicator Light - Illuminates when the rear PTO is engaged.

K - Alternator/Battery Charging Light - Illuminates when the ignition key is in ON position and the engine is not running. It also indicates that an electrical load has exceeded alternator capacity and continued operation could deplete battery reserve.

L - Information Display - Displays operational information.

M - Engine Glow Plug Indicator Light - Illuminates when the engine control unit (ECU) determines the need for engine pre-heating. Time depends on ambient temperature.

N - Engine Oil Pressure Light - Illuminates when there is insufficient engine oil pressure to continue operation.

O - High Exhaust Temperature Indicator (If equipped) - Illuminates when the temperature is high enough inside the exhaust filter to allow active filter cleaning.

P - Exhaust Filter Indicator (If equipped) - Illuminates when soot levels in the filter are high and exhaust filter cleaning is needed.

Q - Trailer 1 Indicator - Illuminates when the hydraulic oil temperature is overheated (If equipped).

R - Trailer 2 Indicator - Starts flashing when trailer turn signal or hazard warning lights are switched on (if equipped).

S - Stop Indicator - Light flashes when a serious malfunction is detected.

UP00731,0000A07-19-18FEB20

Information Display Icons

The following icons will show up in the information display screen if applicable for your specific tractor.



Information Display Icons

LV30645—UN—12DEC19

1 - RIO Active Icon - Illuminates when reverse implement option is active.

2 - Important Icon - This symbol is associated with feedback to operator.

3 - Shift to Neutral Icon - Shift to neutral position..

4 - Wrench Icon - Illuminates when there is an active error shown on the information display panel. May be accompanied by a display message.

5 - Automatic Regeneration Off Icon - Automatic regeneration has been disabled.

6 - Diesel Particulate Filter—Exhaust Filter Icon - When shown on the LCD, this symbol is associated with the display of soot level and filter hours.

7 - Shut PTO Off Icon - Illuminates when the condition requires the PTO to be shutoff.

8 - Engine Overheat Icon - Illuminates when engine coolant temperature is too high.

- 9 - Apply Park Brake Icon** - Illuminates when the condition requires park brake engaged. May be accompanied by a display message.
- 10 - ECU Regeneration Inhibited Icon** - Illuminates if the ECU is preventing regeneration. See your John Deere dealer.
- 11 - Engine Cold Icon** - Illuminates when regeneration requires engine to be above 60° C.
- 12 - Reduce Engine Speed Icon** - Illuminates when regeneration requires initial low idle.
- 13 - Increase Engine Speed Icon** - Illuminates when engine speed needs to be increase..
- 14 - Electrical System Fault Icon** - Illuminates when an electrical fault is present. May be accompanied by a display message.
- 15 - Engine Run Fault Icon** - Illuminates when the operator attempts to engage the starter when the engine is already running. May be accompanied by a display message.
- 16 - Engine Icon** - This symbol is associated with the display of engine hours.
- 17 - Bulb Fault Icon** - Left or right turn signal fault.
- 18 - Operator Out of Seat Icon** - Illuminates when the operator should return to seat..
- 19 - Calibration Mode Icon** - Illuminates when tractor is in calibration mode.
- 20 - eThrottle Active Icon** - Illuminates when eThrottle is active.
- 21 - eThrottle Off Icon** - Illuminates when eThrottle is not active.
- 22 - Ambient Temperature Icon** - Illuminates to show ambient temperature.
- 23 - Mid PTO Icon** - This symbol is associated with the display of Mid PTO speed.
- 24 - Ground Speed Missing Icon** - Illuminates to show transmission fault.
- 25 -Active ICC Icon** - Illuminates to show active ICC diagnostic trouble code.
- 26 - Active TCU Icon** - Illuminates to show active TCU diagnostic trouble code.
- 27 - Tractor Side View Icon** - This symbol is associated with the display of vehicle hours.
- 28 - Hour Meter Icon** - Illuminates when the engine or PTO hour information is shown on the information display panel.
- 29 - Service Alert Icon** - Illuminates when there is an active error shown on the information display panel. May be accompanied by a display message.

30 - PTO Speed - This symbol is associated with the display of PTO speed.

31 - Kilometers/Miles Per Hour - Shows the kilometers / miles per hour the tractor is traveling.

UP00731,0000983-19-17MAR20

Information Display and Display Mode Switch

Normal Operation



LV30672—UN—13NOV19

Left-Hand Switch Module

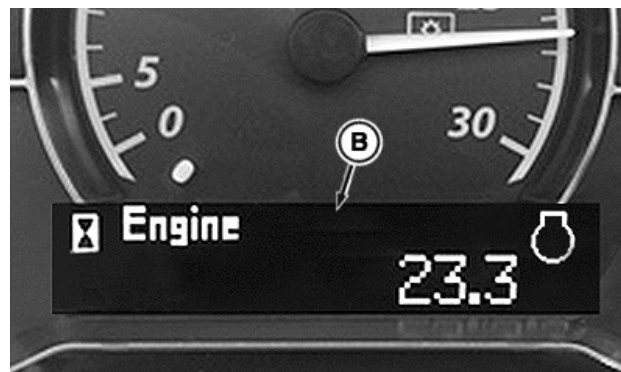

LV25660—UN—23JUN16

Engine Hours

- A—Display Mode Switch**
- B—Information Display Screen**

Press Display Mode Switch (A) to navigate through or select information in the Information Display (B).

Information display screen (B) shows normal operational information in the following order:

Engine Hours ⇒ Vehicle Hours ⇒ PTO Hours

IMPORTANT: Machine damage will occur if a machine operation continues after STOP indicator is displayed. Shut off engine immediately and call your John Deere dealer for assistance before machine operation continues.

Stop, service alert, information messages, and diagnostics are also provided on the information display screen. This information overrides normal operation. Press display mode switch (A) to acknowledge this information and return to the normal operational information.

For additional information on codes, icon descriptions, messaging, and diagnostics, see the On Board Diagnostic Display section.

Programming Mode (If Equipped)

Programming of the machine can be performed with the display mode switch.



LV28765—UN—19DEC17

Release Message

C—Release Message

To enter programming mode, press and hold the Display Mode Switch until Release (C) appears on the display screen.

Programming mode shows programmable feature screens in the following order:

Brightness Mode ⇒ Dimmer Mode ⇒ Language

For more information on Instrument Cluster Display settings, see Electrical and Lighting Operation section.

UP00731,00009EF-19-03DEC19

Engine Operation

Operate Key Switch

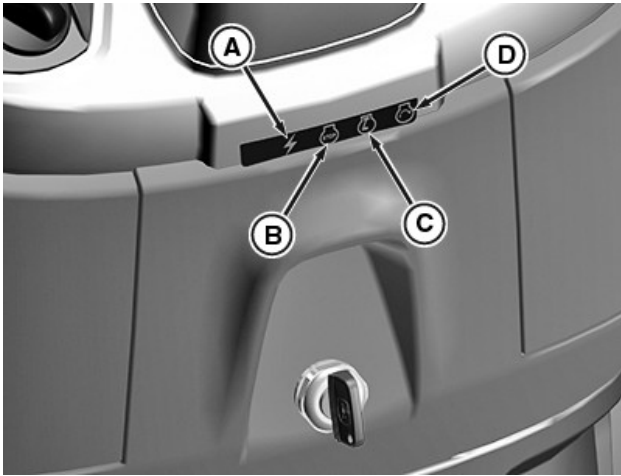

PY46078—UN—01AUG17

A - ACCESSORY Position — Push in and turn key to the accessory position to power electrical functions.

B - OFF Position — All switched power is off, and engine is off

C - ON Position — Move key from OFF to this position. The oil pressure light and battery charging light turns on and activate the glow plugs.

D - START Position — Move key from ON to this position and the starter engages the engine flywheel to start the engine. Release the key to the ON position.

SK35149,000110C-19-21NOV19

Operate Throttle

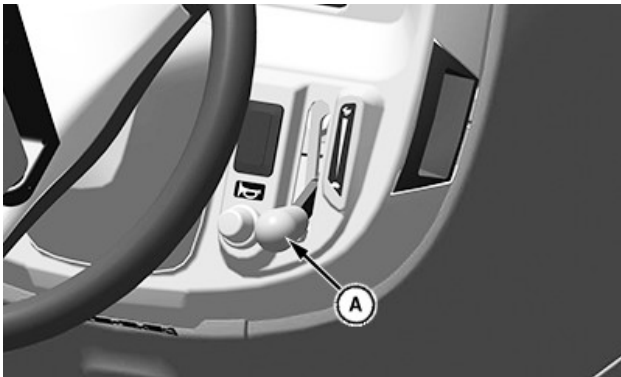

LV29076—UN—02OCT17

A—Throttle Lever

Use the throttle to change engine speeds. Use the throttle in conjunction with the tachometer to set engine speeds.

- **Increase Engine Speed** - Push throttle lever (A) towards the front of the machine.
- **Decrease Engine Speed** - Pull throttle lever (A) towards rear of the machine.

UP00731,00003E8-19-10AUG17

Operate Fuel Shutoff Valve

⚠ CAUTION: Avoid Injury! Close fuel shutoff valve when performing any type of engine service, during transport of the machine, and during storage.

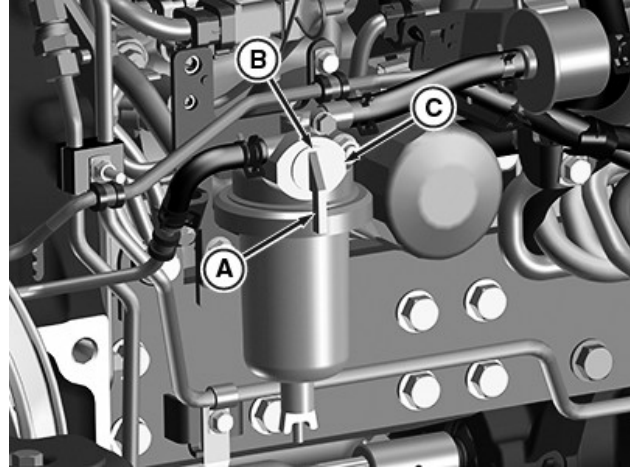

PY38947—UN—17JUL17

A—Fuel shutoff Valve Lever
B—Vertical Position Marked “O”
C—Horizontal Position Marked “C”

1. Open or close fuel shutoff valve lever (A) as required:

- **Open Valve:** Rotate valve lever pointer to the vertical position (B) marked “O”.
- **Close Valve:** Rotate valve lever pointer to the horizontal position (C) marked “C”.

SK35149,000110F-19-17JUL17

Start the Engine

⚠ CAUTION: Avoid Injury! Engine exhaust fumes contain carbon monoxide and can cause serious illness or death.

- Move the machine to an outside area before running the engine.
- If running engine in an enclosed area, make sure that there is adequate ventilation.
- To direct exhaust fumes out of the area, connect a pipe extension to the engine exhaust pipe.
- To clear out the exhaust fumes, allow fresh outside air into the work area.

NOTE: If operating machine in temperatures below -18° C (0°F), installation of the optional engine block heater and hydraulic oil heater is recommended.

If temperature is below 0°C (32°F), follow the additional cold weather starting aids.

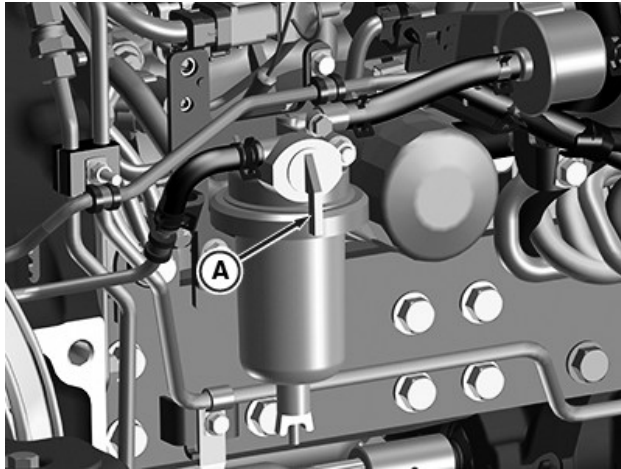

PY28631—UN—28JUL17

Fuel Shutoff Valve

A—Fuel Shutoff Valve

1. Open the fuel shutoff valve (A).
2. Apply park brake.

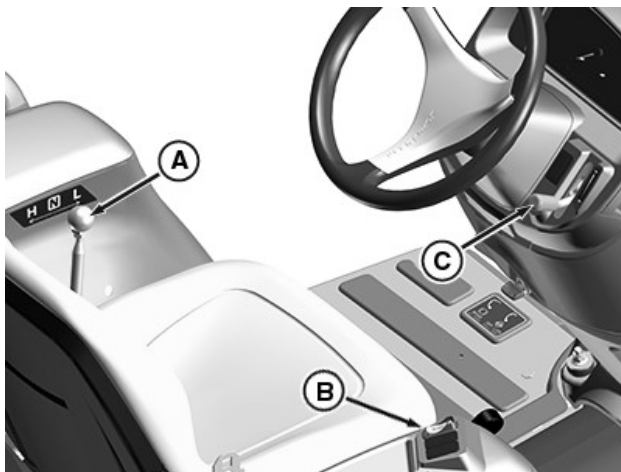

PY38948—UN—28JUL17

- A—Transmission Range Lever**
- B—PTO Switch Knob**
- C—Hand Throttle Lever**

3. Move the transmission range-shift lever (A) to the N position.
4. Confirm PTO switch (B) is in the disengaged/off position.

⚠ CAUTION: Avoid Injury! Check to be sure that area is clear of any bystanders before lowering implements to the ground.

5. Lower any implements to the ground.
6. Set hand throttle (C) to the 1/2-3/4 fast position.
7. Turn ignition key switch to the ON position.
8. Check indicator lights:
 - All indicator lights illuminate.

- All gauges do a full sweep and return to normal.

IMPORTANT: Avoid Damage! Starter can be damaged if the starter is operated for more than 20 seconds at a time:

Wait two minutes before trying again if engine does not start.

9. Turn key switch to START position. Release key when engine starts.

NOTE: If engine does not start, cycle the key back to the off position and restart the procedure.

10. Check indicator lights:

- Engine oil pressure light should go out after 5 seconds of the engine running. If it does not go out, the engine oil pressure may be too low. Stop the engine and check for cause.
- Alternator/battery charging light should go out after 10 seconds of the engine running. If it does not go out, set the engine speed at full throttle.

11. Set hand throttle to the 1/2 fast position for 1 minute without load.

SK35149,0001110-19-17MAR20

Cold Weather Starting Aids

IMPORTANT: Avoid Damage! Glow plugs and air heater are operational during cranking. Using ether or starter fluid during cranking will cause damage to engine.

Recommendations:

- Turn key to ON position for 5-10 seconds to activate glow plugs.
- Install optional engine coolant heater if you operate machine in temperatures below -18° C (0° F).

SK35149,0001111-19-11JUL17

Warm and Idle the Engine

IMPORTANT: Avoid Damage! In cold weather, run engine several minutes to allow engine oil and transmission oil to warm.

NOTE: It is normal for the engine to be louder and for blue-white exhaust smoke to be present during the engine warm-up. The amount of exhaust smoke depends on air temperature.

Warming the Engine:

- Lock the park brake.

- Set hand throttle lever to the 1/2 throttle position for 5 minutes without load.

Idling the Engine:

- Adjust hand throttle lever rearward to set engine speed at low idle speed.

SK35149,0001112-19-11JUL17

Emergency Stopping

1. Remove foot from forward or reverse pedal.
2. Depress brake pedal.
3. Turn key switch to OFF position. Do not release the brake pedal until all moving parts have stopped.
4. Lock the park brake.

SK35149,0001114-19-17MAR20

To Start a Stalled Engine

IMPORTANT: Avoid Damage! If engine stalls while operating under load, start engine immediately to prevent abnormal heat buildup in the engine.

1. Move the transmission range-shift lever to the N (neutral) position.
2. Start engine. Continue with normal operation, or set engine speed at low idle speed for 1 or 2 minutes before stopping.

SK35149,0001113-19-17MAR20

Stop Engine

Normal Stopping

1. Remove foot from forward or reverse pedal.
2. Disengage the PTO.

⚠ CAUTION: Avoid Injury! Check to be sure that area is clear of any bystanders before lowering implements to the ground.

3. Lower any implements to the ground.
4. Fully depress the brake pedal.

⚠ CAUTION: Avoid Injury! Always lock park brake and move the range shift lever to a position other than N (neutral) before leaving machine unattended.

5. Lock the park brake.

IMPORTANT: Avoid Damage! Do not stop engine immediately after hard or extended operation. Keep engine running at low idle for about 2 minutes to prevent heat buildup.

6. Adjust hand throttle rearward to set engine speed at low idle speed. Allow engine to idle for 2 minutes.
7. Turn key switch to OFF position.
8. Remove key.
9. Wait for the engine and all moving parts to stop before leaving the operator station.

Air Intake, Fuel, Coolant, and Exhaust Operation

Using Fuel Shutoff Valve

CAUTION: Avoid injury! Close fuel shutoff valve when performing any type of engine service, during transport of the machine, and during storage.

Locate fuel shutoff valve on the left side of machine on fuel sediment filter.

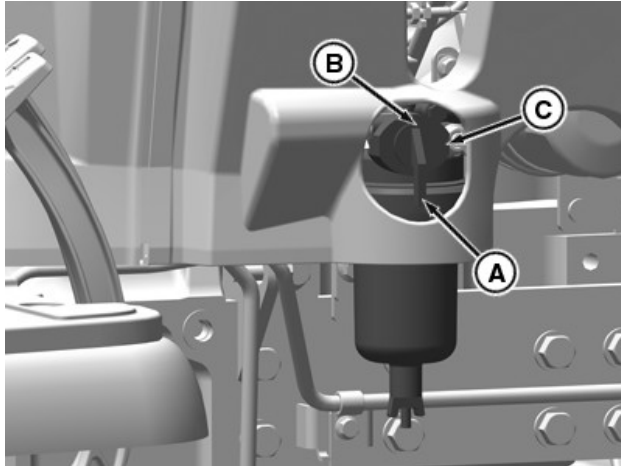

APY20379—UN—10SEP19

A—Fuel Shutoff Valve Lever
B—Vertical Position
C—Horizontal Position

Open or close fuel shutoff valve lever (A) as required:

- **Open Valve:** Rotate valve lever pointer to the vertical position (B).
- **Close Valve:** Rotate valve lever pointer to the horizontal position (C).

PS75950,00008E1-19-05SEP19

- To keep condensation out of the fuel tank, fill the fuel tank at the end of each day of operation.
- Use a non-metallic funnel with a plastic mesh strainer when filling the fuel tank or container.

To prevent condensation and freezing during cold weather, fill fuel tank at the end of each day of operation.

1. Park machine safely.
2. Allow engine to cool.
3. Remove any trash from area around the fuel tank cap.



PY28627—UN—11JUL17

A—Fuel Tank Cap

4. Remove fuel tank cap (A) slowly to allow any pressure built up in the tank to escape.
5. Fill fuel tank only to bottom of filler neck. Do not overfill.
6. Install fuel tank cap.

SK35149,0001115-19-11JUL17

Fill the Fuel Tank

CAUTION: Avoid injury! Fuel vapors are explosive and flammable:

- Shut off engine before filling fuel tank.
- Allow engine to cool before refueling.
- Do not smoke while handling fuel.
- Keep fuel away from flames or sparks.
- Fill fuel tank outdoors or in ventilated area.
- Clean up spilled fuel immediately.
- Use clean approved non-metal container to prevent static electric discharge.

IMPORTANT: Avoid damage! Dirt and water in fuel causes engine damage:

- Clean dirt and debris from the fuel tank opening.
- Use clean, fresh, stabilized fuel.

Use Fuel Gauge

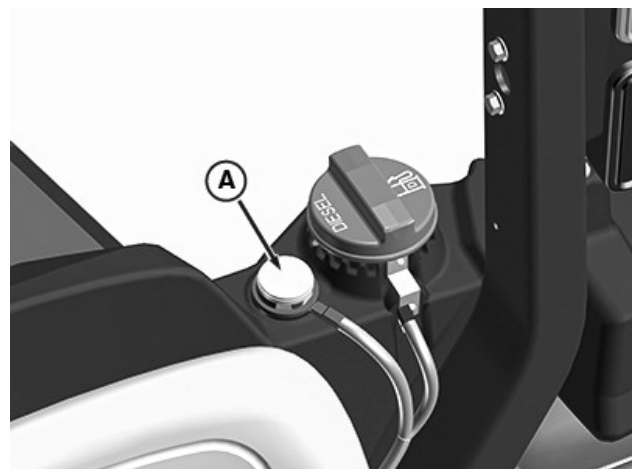

PY38950—UN—17JUL17

A—Fuel Gauge

The fuel gauge (A) shows approximately how much fuel is in the fuel tank.

SK35149,000113D-19-17JUL17

Electrical and Lighting Operation

Turn Signal and Hazard Lights



LV25662—UN—30JUN16

Turn Signal Lights and Hazard Lights			
Activated Switch on Module	Use	Right Amber Light	Left Amber Light
A - Left Turn Signal	On Road, Day Time, Night Time	On	Flashing
A - Right Turn Signal	On Road, Day Time, Night Time	Flashing	On
B - Hazard Lights	On Road, Day Time, Night Time	Flashing	Flashing

To active the turn signals, move the turn signal switch (A) up and down.

To activate or deactivate hazard lights press the hazard light switch (B).

GS25068,0003DD0-19-11NOV19



LV25663—UN—29JUN16

Tractor Lights				
Activated Switch on Module	Use	Tail Lights Red	Work Lights	Head Lights
Off	Field, Day Time	Off	Off	Off
A - Road Lights	On Road, No Traffic, Night Time	On	Off	On
B - Work Lights	Off Road, Night Time	On	On	On

To activate or deactivate road lights, push the road light switch (A).

To activate or deactivate work lights, push the work light switch (B).

To view the hour meter in the instrument panel with the key switch in the off position, push the road light (A) or work light (B) switch.

GS25068,0003DD1-19-26JAN18

Road, Work, and Warning Lights

⚠ CAUTION: Avoid injury! Do not operate on roads with light switch in the field position. Front or Rear work lights may blind or confuse operators of oncoming or following vehicles.

Use Power Port Outlet



PY38952—UN—17JUL17

A—Outlet

The 12-volt power port electrical outlet (A) is used when connecting auxiliary equipment.

SK35149,00011D0-19-31JUL17

Drivetrain Operation

Drive Machine

⚠ CAUTION: Avoid injury! Always check area around the machine for bystanders and obstacles before operating the machine.

IMPORTANT: Avoid damage! To prevent transmission damage, stop machine motion completely before shifting the range shift lever.



LV29936—UN—29JAN18

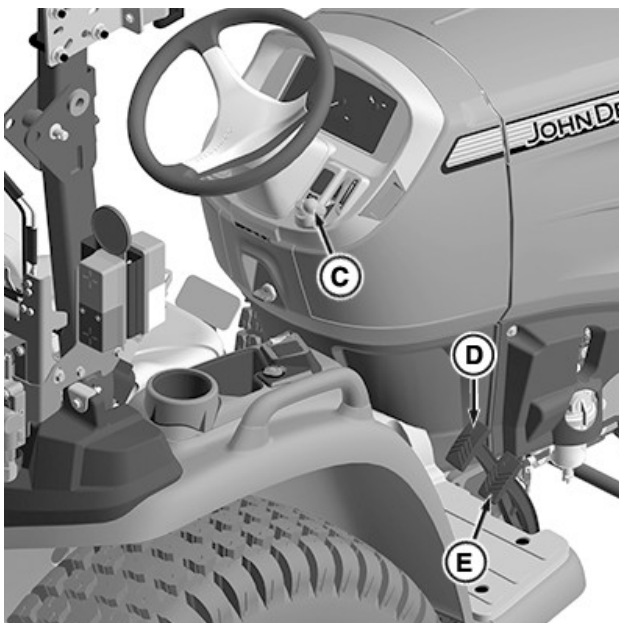

LV29937—UN—29JAN18

- A—Park Brake Lever
- B—Transmission Range Lever
- C—Throttle Lever
- D—Forward Pedal
- E—Reverse Pedal

1. Start machine engine.
2. Unlock park brake (A).

3. Choose low “L” or high “H” speed range on the range shift lever (B).
4. Move throttle lever (C) to desired operating speed.
5. Slowly depress forward travel pedal (D) downward to move forward. Slowly depress reverse travel pedal (E) downward to move in reverse.
6. Release travel pedal to stop machine and change speed range.
7. Fully stop machine motion before turning ignition key switch to off position.

UP00731.00003EF-19-29JAN18

Transmission Operation

Operate the Hydrostatic Transmission



PY38954—UN—17JUL17

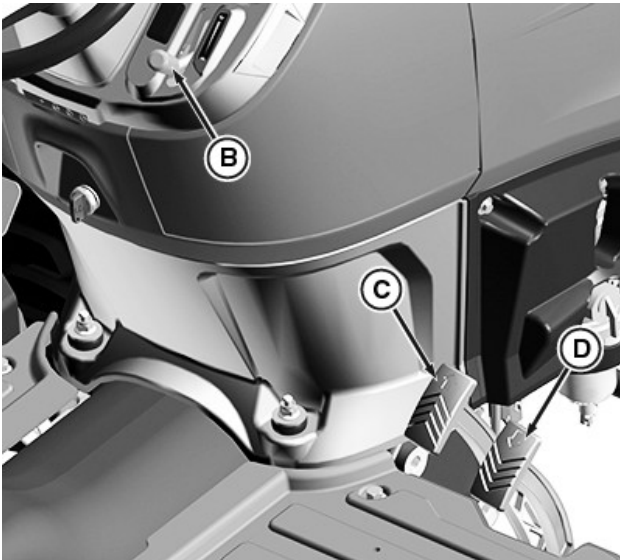

PY38955—UN—17JUL17

- A—Transmission Range Lever
- B—Throttle Lever
- C—Forward Travel Pedal
- D—Reverse Travel Pedal

IMPORTANT: Avoid damage! Select the proper speed range for the job:

- Never overload engine by lugging machine at low idle speeds.
 - Raise engine speed to match expected loads. If a slight increase in engine rpm occurs simultaneously with moving throttle lever (B) forward, engine is not overloaded.
1. The transmission range lever (A) provides two-speed ranges and is used in conjunction with the forward travel pedal (C), and reverse travel pedal (D).
 2. Choose a speed range to match work application.
 - L – Low speed operations such as tilling hard soil, mowing long grass, or heavy hauling. Machine

speed is decreased, but machine power is increased.

- N – Neutral position. Lever must be in the N (neutral) position when starting the engine.
- H – High-speed operations such as light tilling and hauling, mowing short grass and transport. Machine speed is increased, but machine power is decreased.

When changing speed range, stop the machine.

SK35149,0001118-19-17JUL17

Operating Cruise Control (If equipped)

⚠ CAUTION: Avoid injury! Use cruise control only in large, open areas. Shut off before turning or when working in areas with many obstacles.

NOTE: The cruise control is only operational when the machine is traveling forward.

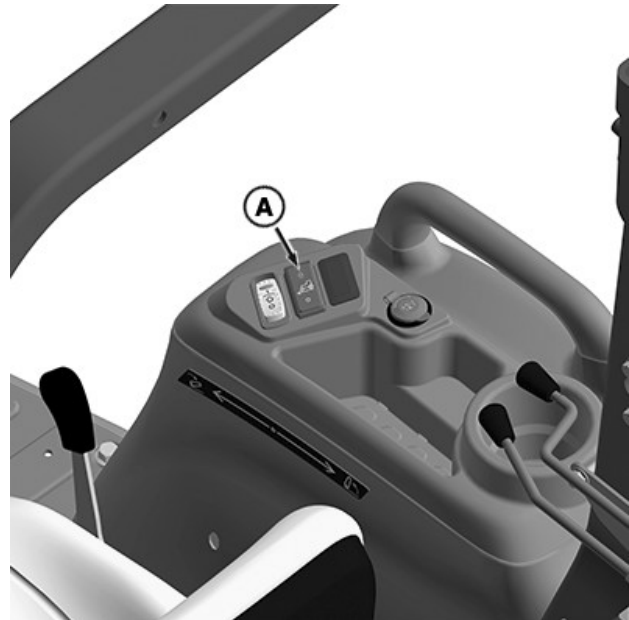

LV29608—UN—20OCT17

- A—Cruise Control Switch

Engaging Cruise Control

1. Depress forward travel pedal until desired travel speed is reached.
2. Fully depress top of cruise control switch (A) to engage cruise control.
3. Release forward travel pedal.
4. To adjust travel speed, disengage cruise control and engage cruise control again at a different speed.

Disengaging Cruise Control

NOTE: The machine will stop if cruise control is disengaged while the machine is in motion. To maintain forward motion, maintain the forward travel pedal while disengaging cruise control.

1. Fully depress bottom of cruise control switch (A), or depress the brake pedal.
2. Ensure machine stops.

UP00731,00004AD-19-29AUG18

MFWD and Front Axle Operation

Use Mechanical Front Wheel Drive (MFWD)

⚠ CAUTION: Avoid Injury! Use extra caution when driving on slopes. To increase traction and provide four-wheel braking, engage mechanical front wheel drive (MFWD) when driving on slopes. The MFWD can improve access to dangerously sloped terrain, which increases the possibility of tipover.

To improve braking on sloped, icy, wet, or graveled surfaces, engage the MFWD. To avoid skidding and loss of steering control, add ballast to the tractor and travel at a reduced speed.

IMPORTANT: Avoid Damage! Always disengage MFWD when driving on a paved surface.

Put the transmission levers in neutral to move the machine when the engine is not running.

Mechanical front wheel drive (MFWD) enables the power train to drive both front and rear axles for improved traction on difficult ground conditions and provides 4-wheel braking. MFWD can be engaged and disengaged on-the-go with light loads and on low traction surfaces.

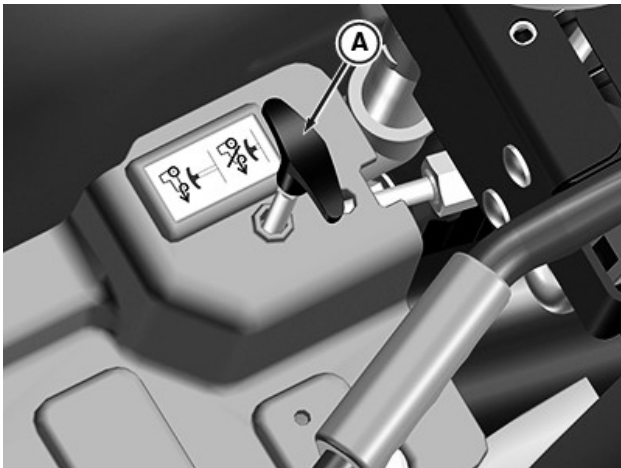

PY38957—UN—17JUL17

A—MFWD Lever

NOTE: It is necessary to reduce engine load to disengage front wheel drive.

Pull up on MFWD lever (A) to engage. Push down MFWD lever to disengage.

Tips for Operating MFWD:

- To ensure proper tire performance in all field conditions, maintain front tire pressure at the maximum allowable level.
- Engage MFWD to provide four-wheel braking.

- Disengage MFWD when driving machine to or from the work site to increase front tire life.

GS25068,0003DDC-19-31JAN18

Differential and Rear Axle Operation

Use Brake/Differential Lock Pedal (Traction Assist)

⚠ CAUTION: Avoid Injury! Driving at high speeds with the traction assist engaged results in loss of steering control. Do not engage traction assist or turn with the traction assist engaged while operating machine at high speeds or on slopes.

The differential lock is used to provide better traction when rear wheels start to slip. With the differential lock engaged, the right and left side rear axles are locked together and both rear wheels turn at equal speeds for maximum traction.

IMPORTANT: Avoid Damage! Using the traction assist function improperly damages the transaxle:

- Reduce speed and allow drive wheels to rotate at same speed before engaging or disengaging traction assist.
- Disengage traction assist when driving on the dry asphalt or concrete.
- Use traction assist only when necessary for improved ground engagement.

NOTE: Turning radius is increased when the differential lock is engaged.

Engage Differential Lock

1. Stop or slow machine movement.

NOTE: Differential lock remains engaged as long as rear wheel slippage occurs. If tires slip and regain traction repeatedly, hold down pedal with foot so differential lock remains engaged.

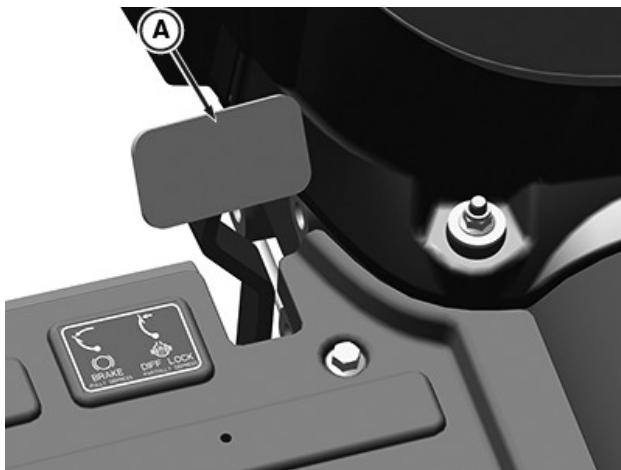

PY38958—UN—17JUL17

A—Differential Lock Pedal

2. To engage differential lock, push down on the differential lock pedal (A) by 20—25 mm (3/4—1 in).

Disengage Differential Lock

Rear wheel slippage keeps differential lock engaged. Lock automatically disengages when traction equalizes.

SK35149,000111C-19-09AUG17

Power Take Off (PTO) Operation

Operate Rear Power-Take-Off (PTO)

CAUTION: Avoid injury! Stay clear of rotating drivelines:

- Entanglement in the rotating driveline can cause serious injury or death.
- Keep hands, feet, and clothing away.
- Make sure that all shields are installed and used properly.
- Stop the engine and be sure that PTO driveline is stopped before getting near it.

IMPORTANT: Avoid Damage! Use rear mounted equipment rated for 540 rpm. Do not operate rear PTO over 540 rpm mark on tachometer.

NOTE: The PTO is only operational with the operator in the seat.

Engaging the PTO

1. Start the engine
2. Set the engine speed to 1500 rpm or less.
3. Move the PTO control lever to the desired operating position.



A—PTO Switch

4. Engage the PTO (A).
5. Adjust the hand throttle forward to the desired speed for the implement used.
 - a. At 2500 engine rpm the mid PTO speed will be 2000 rpm and the rear PTO speed will be 540 rpm, as indicated on the information display.
 - b. If the engine overheats during the PTO operation "Engine Overheat" will display on the information display and the PTO will automatically shutoff. Disengage the PTO switch, engage the park brake and the shut the engine off. Allow sufficient time for the engine to cool. Check the coolant level and add coolant if necessary. Clean debris away from the radiator cooling fins and the front grill. If the PTO does

not engage after the engine has cooled, see your local John Deere Dealer for service.

Operate Rear Power-Take-Off (PTO)—Operator off Seat

1. Sit on the operator seat.
2. Lock the park brake.
3. Move the range shift lever to the N (neutral) position.



PY38959—UN—17JUL17

A—PTO Switch

4. Make sure the PTO switch (A) is in the disengaged position.
5. Start the engine.
6. Set engine speed to 1500 rpm or less.
7. Engage the PTO.
8. Push and hold the PTO switch in the engaged position for at least 2 seconds. "Hold" is shown in the display.
9. Exit the seat when "Exit Seat" is shown in the display. After exiting, "Stationary PTO Active" is shown on the display.

NOTE: After exiting seat, if the seat switch is re-engaged (operator sits in the seat) and then disengaged (operator leaves the seat), the PTO will automatically disengage. "Operator Out of Seat" displays on the information display.

10. Adjust the throttle lever forward to the desired speed for the implement used.

Disengaging the PTO

1. Adjust engine rpm to low idle.
2. Push PTO switch rearward to the disengaged/off position.

UP00731,00009BA-19-10MAR20

Steering and Brake Operation

Operate Brake/Differential Lock Pedal

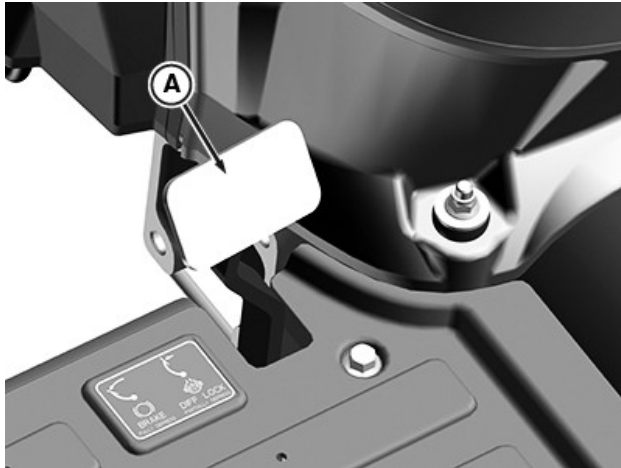

PY38960—UN—17JUL17

A—Brake/Differential Lock Pedal

1. To operate brakes, fully depress brake pedal (A).
2. To operate differential lock, partially depress (20-25 mm (3/4 - 1 in)) brake pedal.

SK35149,0001121-19-29AUG18

To release park brake, lift up on park brake lever and depress park brake release button (B). Lower park brake lever, completely, to fully disengage park brake.

SK35149,0001122-19-17JUL17

Operate Park Brake

⚠ CAUTION: Avoid Injury! Engage park brake and move transmission range shift lever to a position other than N (neutral) before leaving machine unattended. Transmissions will not prevent machine motion without the park brake engaged.

NOTE: Light on the dash illuminates when park brake is engaged.

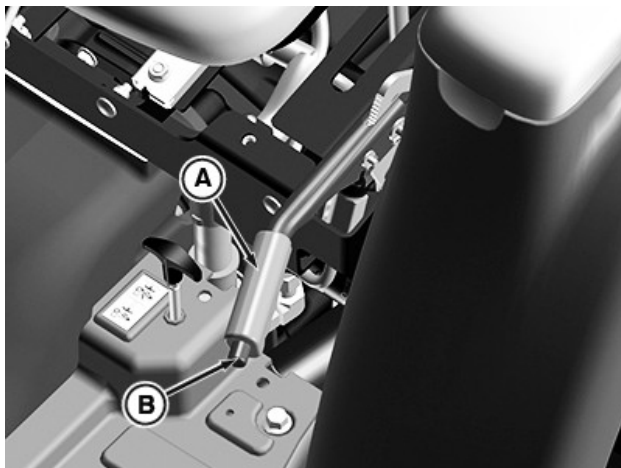

PY38961—UN—08AUG17

A—Park Brake Lever
B—Park Brake Release Button

To engage park brake, lift up on park brake lever (A) ensuring that it ratchets up and stays in position.

Hydraulics Operation

Warm Hydraulic System Oil

IMPORTANT: To prevent damage to the hydraulic pump or relief valve, do not exceed 2 to 3 minutes of warm-up time.

Hydraulic system is slow to function when the tractor is started in cold weather. The reason is because cold oil does not flow easily through the filter screen or the hydraulic system filter. Steering slows until system warms up. Hydraulic system functions normally after the oil warms up.

1. Start the machine and idle at low idle.
2. Turn and hold steering wheel in full left or right turn.

SK35149,0001124-19-26JAN18

Hydraulics Information

For hydraulic operation of components, see specific component section. For example, operating the selective control valves (SCV) is in the Selective Control Valve Operation section.

SK35149,0001125-19-13JUL17

Hitch and Drawbar Operation

Operate Attachments

When operating attachments, check full range of three point hitch travel each time a new attachment or implement is mounted. Watch for hoses and attachment parts throughout the three point hitch travel range. Adjust the depth stop as needed. Some attachments with short driveshafts require an upstop, see your John Deere Dealer. The driveshaft can be damaged if attachments are operated at too high of an angle.

SK35149,0001126-19-13JUL17

Operate 3-Point Hitch

NOTE: The 3-point hitch on your machine is classified as a limited Category 1 hitch.

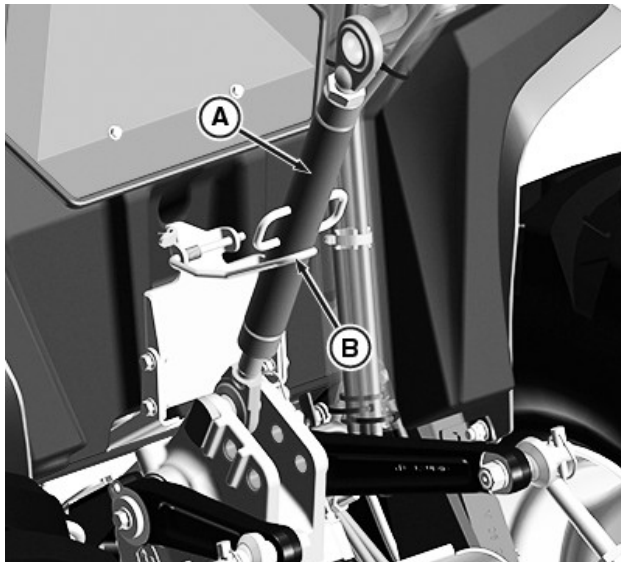

PY38962—UN—17JUL17

A—Center Link
B—Storage Hook

Place center link (A) in the storage hook (B) when hitch is not in use.

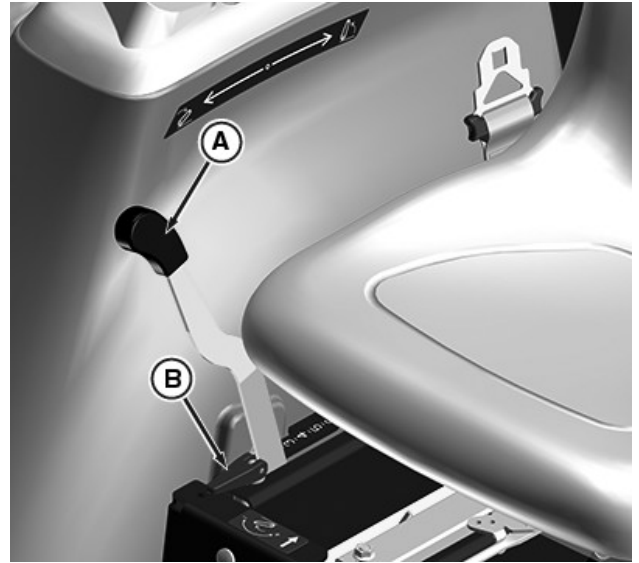

PY38963—UN—17JUL17

A—Rockshaft Lever
B—Depth Stop Lever

Use rockshaft lever (A) to raise and lower equipment attached to the 3-point hitch.

- To lower implement: Push lever forward.
- To raise implement: Pull lever rearward.

Position control can be used to maintain the operating depth of the implement. To adjust the operating depth:

1. Unlock the depth stop lever (B) and slide toward the front of the console completely.
2. Operate the implement for several minutes to determine the desired operating depth.
3. Slide the depth stop against the rockshaft lever and lock it in position.

NOTE: The calibrated label settings below the rockshaft lever are for reference only and do not signify specific operating depths.

- The implement operates in same position each time the rockshaft lever is pushed against the depth stop.

CM74493,00000D8-19-29JAN18

Positioning Center Link

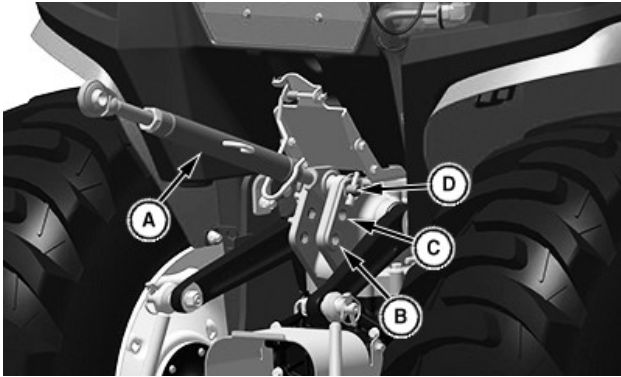

LV29169—UN—08SEP17

- A—Center Link
- B—Light to Medium Draft Loads
- C—Medium to Heavy Draft Loads
- D—Very Heavy Draft Loads

- **For light and medium draft loads:** Install center link (A) in bottom hole (B) of mounting bracket. Example of light and medium draft load implements include a landscape rake. A category 1 implement tilts forward while raising in this position.
- **For medium and heavy draft loads:** Install center link in middle hole (C) of mounting bracket. Example of medium and heavy draft load implements include a tiller or box blade. A category 1 implement tilts forward slightly while raising in this position.
- **For heavy draft loads:** Install center link in top hole (D) of mounting bracket. Example of heavy draft load implements includes a plow or ripper. A category 1 implement rises, but angle remains constant.

CM74493,00000D7-19-29JAN18

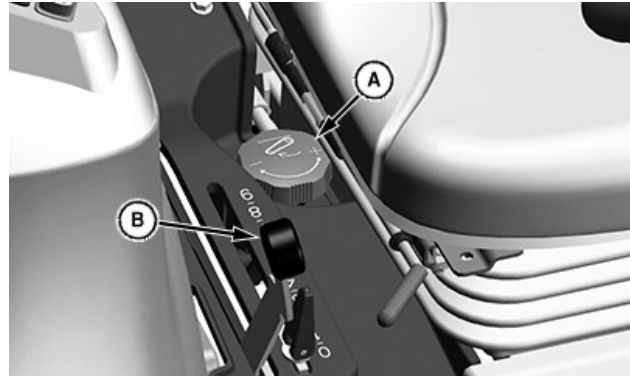

LV29081—UN—16AUG17

- A—Rate-of-Drop Knob
- B—Rockshaft Control Lever

Increase Rate-of-Drop: Rotate rate-of-drop knob (A) counterclockwise to make drop faster.

Decrease Rate-of-Drop: Rotate rate-of-drop knob (A) clockwise to make drop slower.

⚠ CAUTION: Avoid Injury! Do not use the rockshaft drop/lock valve for holding an attachment in raised position for service work. Loss of hydraulic pressure could result in sudden drop of attachment. Lower attachment onto blocks or remove from machine before servicing.

Lock 3-Point Hitch: Rotate rate-of-drop knob clockwise until tight.

Unlock 3-Point Hitch: Rotate rate-of-drop knob counterclockwise.

UP00731,00003F0-19-10AUG17

Operate Rate-of-Drop

The rate-of-drop valve controls the rate of rockshaft drop when the rockshaft lever is operated. This provides direct rate-of-drop control for 3-point hitch-mounted implements. The valve can also be used to lock the rockshaft (3-point hitch) in a desired position.

⚠ CAUTION: Avoid injury! Excessive rate-of-drop can cause injury or damage. Fully lowering implement should take at least 2 seconds.

IMPORTANT: Avoid damage! To prevent overheating hydraulic oil and damaging machine, do not raise rockshaft when rate-of-drop valve is closed.

Use Draft Link and Center Link

⚠ CAUTION: Avoid injury! Look down and behind before and while backing. Clear area of all bystanders before backing machine.

1. Slowly back machine into position to align draft links with implement lift brackets.
2. Park machine safely.



A—Draft Link
B—Center Link

PY38964—UN—17JUL17

3. Connect draft links (A) to the implement.
4. Secure implement with quick lock pins.

SK35149,0001129-19-18JUL17

Level Implement Front-to-Rear

1. Park machine safely.

NOTE: When the 3-point hitch is not being used, return center link to the storage hook (A).

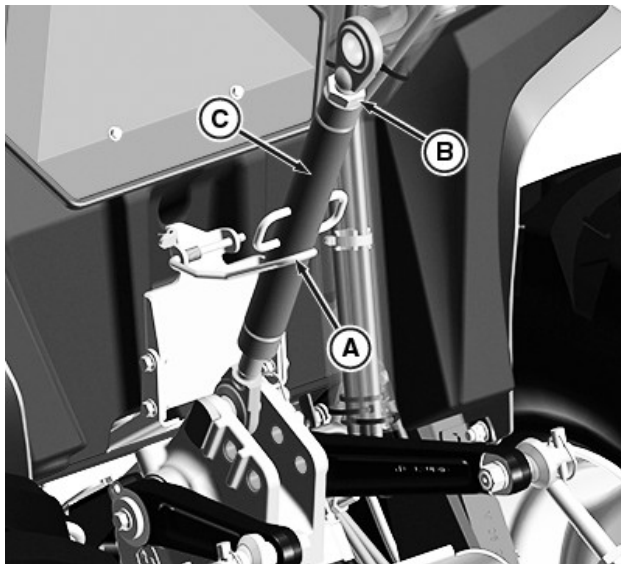

A—Storage Hook
B—Locknut
C—Center Link Body

PY38965—UN—17JUL17

2. Lower implement to ground to relieve pressure on center link.

3. Loosen locknut (B).

IMPORTANT: Avoid damage! To avoid threads being damaged, do not turn center link body past the stops.

4. Lengthen or shorten the center link as needed. To lengthen or shorten the center link, rotate center link body (C).
5. Tighten locknut (B).

SK35149,000112A-19-18JUL17

Level Implement Side-to-Side

1. Lower any rear-mount implement to the ground.
2. Park machine safely.



A—Turnbuckle
B—Locknut

PY38966—UN—10AUG17

3. Loosen locknut (B).
4. Rotate turnbuckle (A) to raise or lower draft link until 3-point hitch-mounted implement is level from side-to-side.
5. Tighten locknut (B).

SK35149,000112B-19-29AUG18

Adjust Implement Side-to-Side Sway

NOTE: Check implement operator manual procedure for adjusting sway links. When sway links have been properly adjusted, the position of links control the side sway of the implement.

1. Lower any rear mount implement to the ground.
2. Park machine safely.

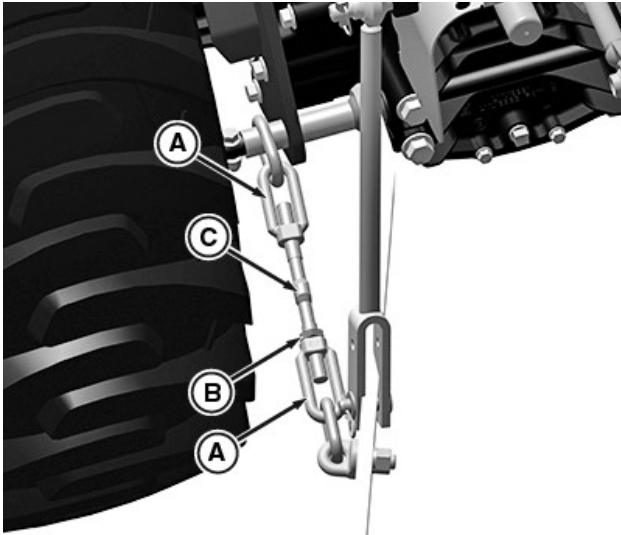

- A—Sway Link
B—Lock Nut
C—Sway Link Adjusting Rod

PY38967—UN—17JUL17

3. Loosen lock nut (B).
4. To adjust length, rotate the sway link adjusting rod (C).
5. Tighten lock nut (B).

SK35149,000112C-19-01AUG17

IMPORTANT: Avoid damage! For drawn PTO-driven implements, the drawbar must be in the operating position.

The drawbar is equipped with three adjusting holes for changing drawbar length and one hole for storage.

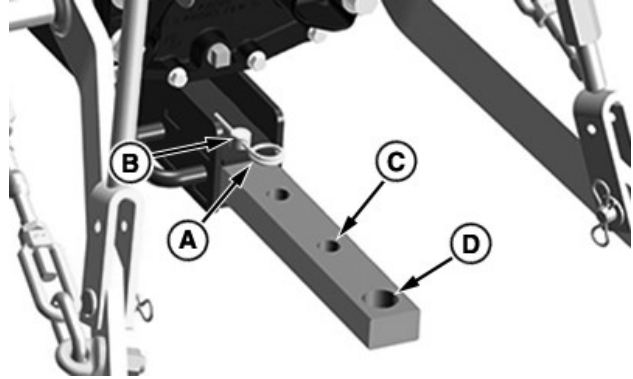

LV30685—UN—04DEC19

- A—Cotter Pin
B—Drilled Pin
C—Operating Position
D—Storage Position

1. Remove the cotter pin (A) and drilled pin (B).
2. Adjust the drawbar to one of the operating positions (C), or to the storage position (D).
3. Install the drilled pin (B) up from the bottom of tractor. Secure with the cotter pin (A).

UP00731,0000A0D-19-05DEC19

Operate Drawbar Hitch (If Equipped)

CAUTION: Avoid Injury! Use only the drawbar that was provided with the machine. Do not install or use any other type drawbar.

To avoid rearward upset, all towed loads must be attached to the drawbar, not just to the center link or draft arms.

IMPORTANT: Avoid damage! Maximum static vertical load on drawbar is not to exceed maximum recommendations. Drive slowly with heavy loads.

Maximum Drawbar Loads

Certain heavy equipment such as a loaded single-axle trailer can place excessive strain on the drawbar. Strain is greatly increased by speed and rough ground. Do not exceed the maximum static vertical loads on drawbar, see Specifications section.

Adjust Drawbar Length

Selective Control Valve Operation

Connect Implement Hydraulic Hoses

⚠ CAUTION: Avoid injury! Escaping fluid under pressure can penetrate the skin causing serious injury. Relieve hydraulic system pressure by moving hydraulic controls in all directions before connecting or disconnecting hydraulic lines.

1. Park machine safely.
2. Relieve all hydraulic pressure by moving SCV lever rearward-to-forward and side-to-side several times.
3. Refer to implement operator manual for instructions on connecting hydraulic hoses to couplers.

CM74493.00000D9-19-29JAN18

- SCV Lever Forward—Boom Lower
- SCV Lever Rearward—Boom Raise

Boom Float—Move the lever to the full forward or “float” position to remove pressure in both connector lines. This allows the loader to follow the contour of the ground without down force pressure.

Refer to information label (B) for assistance. See your implement Operator's Manual for implement functions which correspond to lever positions.

CM74493.00000DA-19-29JAN18

Operate Selective Control Valve (SCV) Lock Lever

Operate Selective Control Valve (SCV)

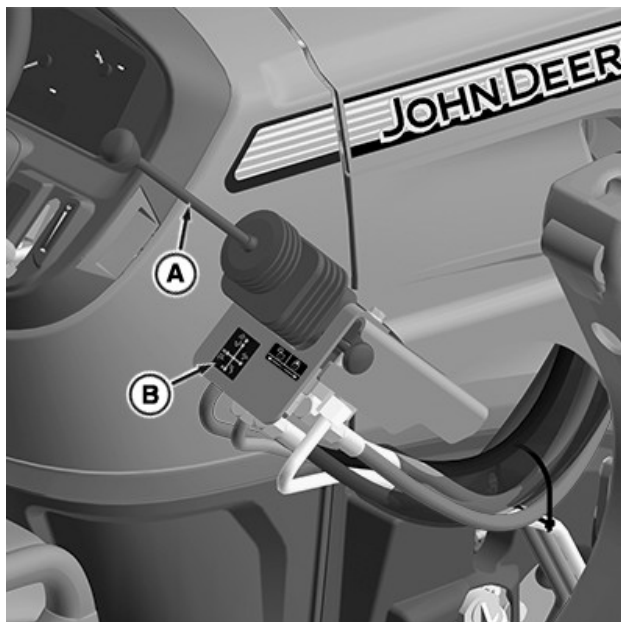

LV29910—UN—19JAN18

A—Selective Control Valve Lever
B—Information Label

This machine series is equipped with a hydraulic Selective Control Valve (SCV) and hydraulic outlets to operate the hydraulic front end loader.

The loader mounted SCV ports are color marked for easy hookup.

Front end loader hoses are also marked with color tie-bands. Match the color marked hose ends to the color marked ports on the SCV when making connections.

The SCV lever (A) controls the oil flow to the corresponding SCV ports. Refer to the information label (B) for assistance during operation.

- SCV Lever Left—Bucket Curl
- SCV Lever Right—Bucket Dump

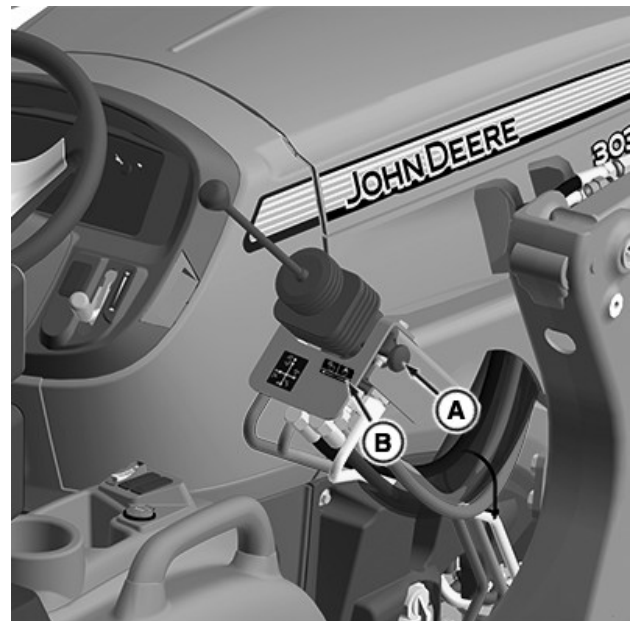

LV29911—UN—19JAN18

A—Lock Lever
B—Label

- Push the lock lever (A) to allow SCV lever movement in all directions. Operation of the SCV is unlocked.
- Pull the lock lever (A) to prohibit SCV lever movement in all directions. Operation of the SCV is locked.
- Operation of the lock lever is indicated on label (B).

CM74493.00000DB-19-29JAN18

Operate Hydraulic Dual Rear (SCV) Selective Control Valve

CAUTION: Avoid injury! Escaping fluid under high pressure can penetrate the skin and cause serious injury. Avoid the hazard by relieving pressure before connecting hydraulic or other lines. Tighten all connections before applying pressure.

- Search for leaks with a piece of cardboard. Protect hands and body from high-pressure fluids.
- If an accident occurs, see a doctor immediately. Any fluid injected into the skin must be surgically removed within a few hours or gangrene may result. Doctors unfamiliar with this type of injury should reference a knowledgeable medical source. Such information is available from Deere & Company Medical Department in Moline, Illinois, United States. In the United States and Canada only, this information may be obtained by calling 1-800-822-8262.

IMPORTANT: Avoid damage! To prevent contamination of female quick couplers, install color-coded hose ends in the couplers when not being used.

This machine can be equipped with an optional dual rear hydraulic selective control valve (SCV) outlet kit to operate hydraulically driven implements from outlets at the rear-mount position.

The machine-mounted hydraulic outlets are female quick couplers.

V Rear Outlet Selective Control Valve (SCV)

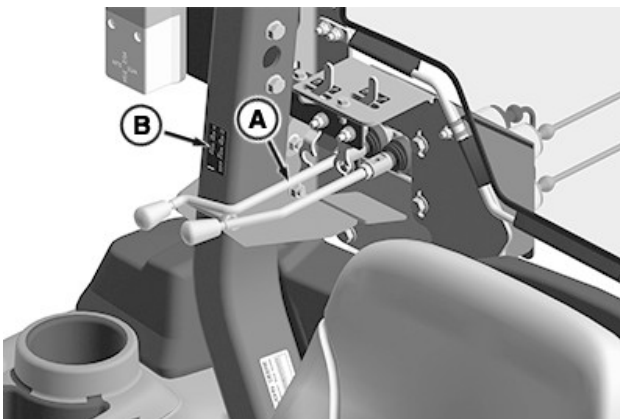

LV29938—UN—29JAN18

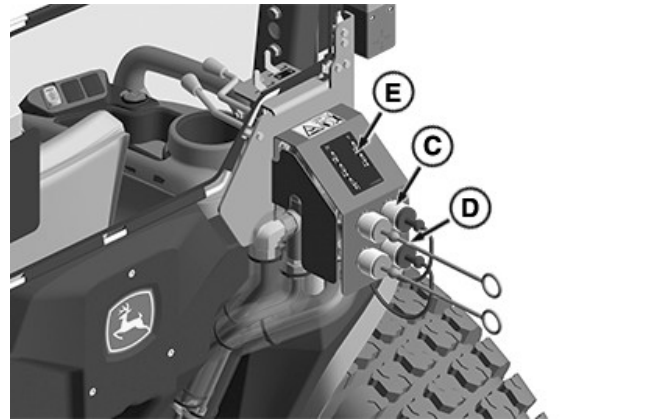

LV29939—UN—29JAN18

- A—IV Rear Selective Control Lever
- B—Information Label
- C—Coupler
- D—Coupler
- E—Information Label

- **Cylinder Extend**—Push V rear selective control lever (A) downward to allow flow from the circuit out through coupler (D) and return to the machine through coupler (C).
- **Cylinder Retract** — Push V rear selective control lever (A) upward to allow flow from the circuit out through coupler (C) and return to the machine through coupler (D).

Refer to the information labels (B and E) for assistance. See your implement operator manual for implement functions which correspond to lever positions.

IV Rear Outlet Selective Control Valve (SCV)

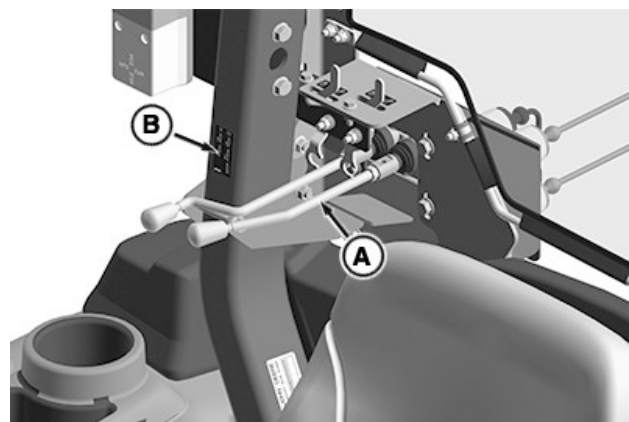

LV29944—UN—29JAN18

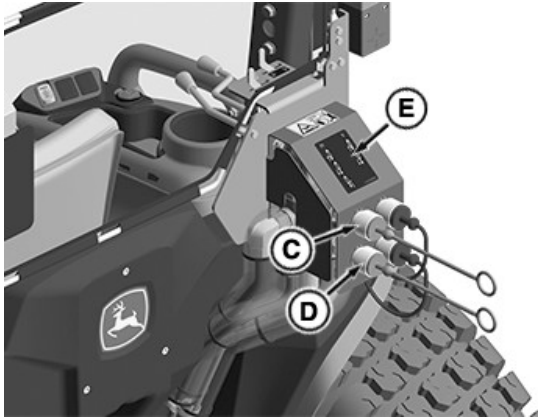

LV29945—UN—29JAN18

- A—IV Rear Selective Control Lever
- B—Information Label
- C—Coupler
- D—Coupler
- E—Information Label

- **Cylinder Extend**—Push IV rear selective control lever (A) downward to allow flow from the circuit out through coupler (D) and return to the machine through coupler (C).
- **Cylinder Retract** — Push IV rear selective control lever (A) upward to allow flow from the circuit out through coupler (C) and return to the machine through coupler (D).

Refer to the information labels (B and E) for assistance. See your implement operator manual for implement functions which correspond to lever positions.

Float Position (IV Rear Outlet SCV)

“Float” operation allows cylinder to extend and retract freely, such as when an implement follows ground contour.

- Push lever forward, through retract, into detent to operate “float” feature.
- Manually return lever to the center position when “float” is no longer required.

CM74493,00000DC-19-17MAR20

Operate Hydraulic Dual Rear (SCV) Lock Lever

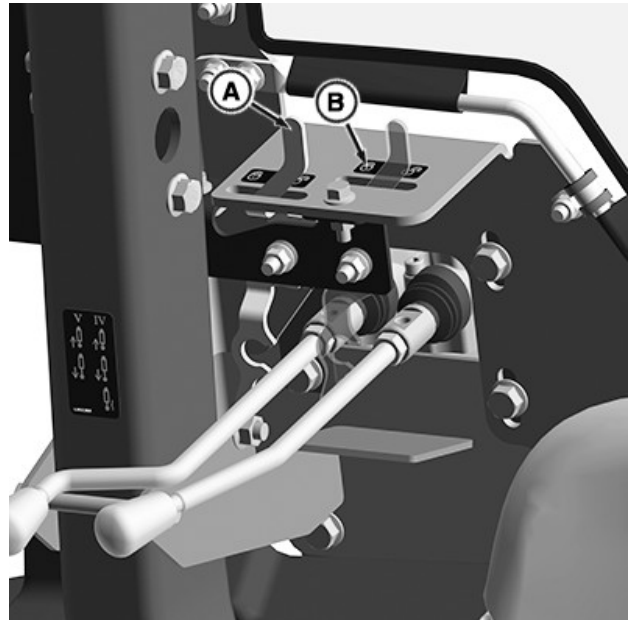

LV29946—UN—30JAN18

- A—Lock Lever
- B—Label

- Push the lock lever (A) to the left to allow SCV lever movement in all directions. Operation of the SCV is unlocked.
- Pull the lock lever (A) to the right to prohibit SCV lever movement in all directions. Operation of the SCV is locked.
- Operation of the lock lever is indicated on label (B).

CM74493,00000FF-19-30JAN18

Wheels and Tires Operation

Tire Labeling, Ascertain the Load Capacity of Tires

CAUTION: Load capacity of tires and permissible axle loads must not be exceeded under any circumstances.

Tire load capacities stated in the Operator's Manual apply for a ground speed of 40 km/h (25 mph).

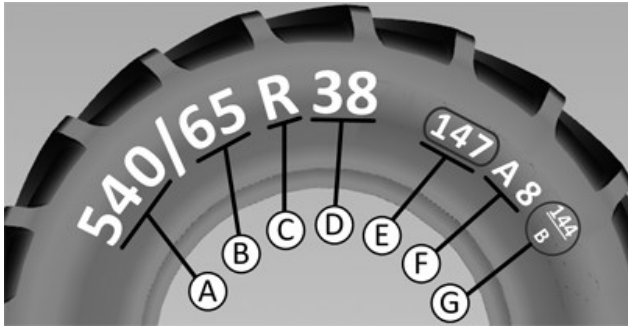

Example of Manufacturer's Information on Sidewall of Tires
LX299192—UN—18NOV16

Speed Index	A6	A8	B	C	D
km/h	30	40	50	60	65
mph	19	25	31	37	40

Example: Tire 540/65R38 147A8 (144/B)		
Tire Load Index (LI)	147	3075 kg (6780 lb) load capacity per tire
Speed Index	A8	40 km/h (25 mph)
+		
Tire Load Index (LI)	(144)	2800 kg (6175 lb) load capacity per tire
Speed Index	(B)	50 km/h (31 mph)

Permissible deviation in load capacity in relation to speed index, in percent:					
Speed Index	Permissible Ground Speed		Permissible deviation in load capacity of tires at:		
	km/h	mph	30 km/h (19 mph)	40 km/h (25 mph)	50 km/h (31 mph)
A6	30	19	± 0%	- 10%	—
A8	40	25	+ 7%	± 0%	- 9%
D	65	40	+ 15%	+ 9.5%	+ 5%

CM74493,00000DE-19-29JAN18

Manufacturer's Information on Sidewall of Tires		
A	Tire Width	Width in millimeters
B	Tire Section	Ratio of tire height to tire width
C	Type	"R" = Radical "—" = cross-ply (example: 18.4-38)
D	Rim Diameter	Diameter in inches
E	Tire Load Index (LI)	Maximum permissible load capacity per tire, in relation to speed index (F)
F	Speed Index	Maximum permissible ground speed at which (E) applies
G	Tire Load Index (LI)	Tire load capacity at an alternative permitted ground speed
	Speed Index	

Apply to your tire dealership or directly to the tire manufacturer for more information on tires and tables concerning load index and ground speed.

Tire load capacity at a specific ground speed:

On the sidewall of the tire can be seen details of its load capacity (E) at maximum permissible ground speed (F).

If the tire manufacturer has approved the same tire for another ground speed, additional information (G) is provided. In this case, note especially that tire load capacity may change in relation to the maximum permissible ground speed.

Select Tire Inflation Pressure

IMPORTANT: Any tire inflation quoted in this Operator's Manual is binding.

Tires must never be inflated to a pressure higher than the maximum value stated on the tire.

Use a tire pressure of 2 bar (29 psi) if no other pressure value is available.

Particular attention must be paid to inflation pressures for row-crop tires, special tires, and tires with liquid ballast. If in doubt, obtain the correct inflation pressure from the tire manufacturer.

Tire inflation pressure plays a vital role in determining vehicle behavior, tractive force, and fuel consumption.

Since the correct tire pressure is dependent on many different factors, it is not possible to make a general recommendation.

When selecting inflation pressure, take the following into account:

- Tire manufacturer
- Tire size
- Axle load of machine

- Ballast on machine
- Whether tire is used on a front or rear wheel
- Nature of the work to be done
- Soil conditions
- Expected travel speed

Rear Tires—Capacity			
Tire Size	Tread	kg	lb
11.2-24 6PR R1	R1	1060	2336
43x16-20 4PR R4	R4	1400	3086
320 / 70 R24	R1	1250	2755

CM74493.00000E1-19-30JAN18

To ascertain the pressure for specific applications, refer to the inflation pressure tables provided by the tire manufacturers. Many tire manufacturers provide apps on their Internet portals which allow the recommended tire pressure to be calculated.

CM74493.00000DF-19-29JAN18

Tire Combinations

In order to achieve maximum drawbar pull, maintain proper steering ability, and reduce tire wear and fuel consumption, comply with the correct tire combinations.

Tire Combinations	
Rear	15.00-19.5 6PR R4
Front	25x8.5-14 6PR R4
Rear	41x14.00-20 4PR R3
Front	27x8.50-15 6PR R3
Rear	11.2-24 6PR R1
Front	7.00-14 6PR R1
Rear	43x16-20 4PR R4
Front	27x8.50-15 4PR R4
Rear	320 / 70 R24 R1
Front	200 / 70 R16 R1

CM74493.00000E0-19-30JAN18

Front and Rear Tire Capacity

Front Tires—Capacity			
Tire Size	Tread	kg	lb
25x8.5-14 6PR R4	R4	950	2094
27x8.50-15 6PR R3	R3	710	1565
7.00-14 6PR R1	R1	730	1609
27x8.50-15 4PR R4	R4	710	1565
200 / 70 R16	R1	670	1477

Rear Tires—Capacity			
Tire Size	Tread	kg	lb
15.00-19.5 6PR R4	R4	2725	6007
41x14.00-20 4PR R3	R3	1400	3086

Ballast

Ballast Machine

⚠ CAUTION: Avoid injury! Ballasted machine becomes unstable when attachment is raised. Always drive slowly over uneven ground and when turning with raised attachment.

IMPORTANT: Avoid damage! Do not overload tires. Do not exceed maximum inflation pressure or maximum load capacity of tire.

IMPORTANT: Avoid damage! Remove ballast from the machine when no longer needed.

- Add weight to the machine front end if needed for stability. Heavy pulling and heavy rear mounted implements tend to lift front wheels. To maintain steering control and prevent tip over, ensure that enough ballast has been added. Remove weight when it is no longer needed.
- See tire maximum inflation pressure and maximum load capacities in the Specifications section.
- Verify maximum tire inflation pressure and maximum load information if embossed into the tire side wall.

SK35149,0001161-19-29JAN18

Implement Code	Minimum number of 19 kg (42 lb) weights	Minimum number of 32 kg (70 lb) weights
37	3	2
39	4	3
41	5	3
43	5	3
45	6	4
47	7	4
49	7	5
51	8	5
53	9	5
55	10	6
57	10	6
59	Not Recommended	7
61	Not Recommended	7
63	Not Recommended	8
65	Not Recommended	8
67	Not Recommended	8
69	Not Recommended	9
71	Not Recommended	9
73	Not Recommended	Not Recommended

UP00731,000048B-19-30JUL18

Implement Codes

Use the following tables to determine the number of front weights to use with John Deere implements. Implement code data can be found in the ballasting section of the implement operator's manual.

Match the implement code from the implement manual with the codes for your machine and type of hitch. If the code falls between two numbers in the table, use the next higher number for the number of front weights to use with that implement.

These codes are for ideal conditions. Actual field conditions can require additional ballast. Some John Deere implements require using a certain number of front weights rather than giving implement codes.

Maximum recommended implement codes:

- Base tractor: 21
- Tractor with loader: 52
- Tractor with loader; bucket removed: 36

Implement Code	Minimum number of 19 kg (42 lb) weights	Minimum number of 32 kg (70 lb) weights
25	0	0
27	0	0
29	1	0
31	1	1
33	2	1
35	3	2

Tire Capacities

IMPORTANT: Avoid damage! Do not overload tires. Do not exceed tire maximum inflation pressure or maximum load capacity.

If necessary ballast exceeds tire load capacity, reduce load or install other tires.

See tire maximum inflation pressure in the Wheels and Tires Maintenance section.

See maximum load capacities in the Wheels and Tires Operation section.

Verify maximum tire inflation pressure and maximum load information if embossed into the tire side wall.

CM74493,00000E2-19-31JAN18

Use Optional Rear Cast Iron Wheel Weights

⚠ CAUTION: Avoid injury! Machine component or attachment is heavy. Use a safe lifting device or get an assistant to help lift, install, or remove component or attachment.

NOTE: Avoid damage! Do not overload tires. Do not exceed tire maximum inflation pressure or maximum load capacity.

1. Mount rear wheels in the wide position for improved stability.

2. Fasten weight to each rear wheel using a safe lifting device. A total of three weights per wheel may be used. See your implement operator's manual for installation and number of weights to use.

Rear wheel weights are available from your John Deere Dealer.

SK35149,0001163-19-29JAN18

Use Optional Rear Ballast Box

CAUTION: Avoid injury! To improve front loader-machine stability, use of the ballast box is recommended. Use ballast as recommended in the loader operator's manual.

The rear ballast box is used for carrying ballast on the 3-point hitch. Approximate weight of different materials is given in the implement operator's manual.

SK35149,0001164-19-20JUL17

Use Liquid Weight in Tires

CAUTION: Avoid injury! Installing liquid ballast requires special equipment and training. Injury will occur from the exploding tire. Have the job done by your John Deere dealer or a tire service store.

IMPORTANT: Avoid Damage! Cover rim completely with solution to avoid corrosion, but never more than 90 percent full. More solution would leave too little air space to absorb shocks. Damage to tire could occur.

NOTE: Use of alcohol as ballast is not recommended. Calcium chloride solution is heavier and more economical.

A solution of water and calcium chloride provides safe economical ballast, and prevents freezing. If used properly, it will not damage tires, tubes, or rims.

A mixture of 0.4 kg of calcium chloride per liter of water (3.5 lb per gallon), does not freeze solid above -45°C (-50°F).

Fill tubeless tires at least to the valve stem level (minimum 75% full). Less solution would expose part of rim, possibly causing corrosion.

Tube-type tires may be filled to any level below 90%.

SK35149,0001165-19-20JUL17

Use Optional Front Weights



LV29171—UN—08SEP17

A—Front Weight Bracket

IMPORTANT: Avoid damage! Do not install weights on the front bumper plate, damage to can occur to the front grille. Use optional bolt-on weight bracket for front weights.

Front weight bracket (A) is an optional bolt-on to the machine frame. The bracket holds up to ten Quick-Tatch™ weights.

Each weight is 19 kg (42 lb).

Quik-Tatch™ weights and attaching hardware are available at your John Deere dealer.

See your implement operator's manual for installation and required number of weights to use.

UP00731,0000427-19-19SEP17

Additional Equipment Operation

Additional Equipment Operation

To operate attachments or implements, refer to relevant Operator's Manual.

SK35149,0001167-19-20JUL17

Front Loader Installation

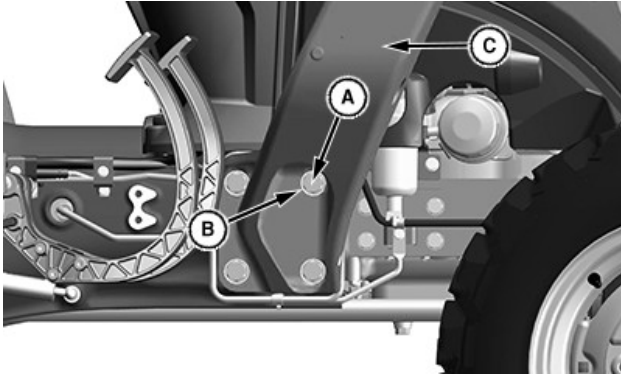

LV29472—UN—03OCT17

Right Side Shown

- A— M16 x 45 Hex Head Cap Screw (4 Used)
- B—Washer (4 Used)
- C—Mounting Frame

Hardware	
Hex Head Screw	
Quantity	4 per side
Drive Size / width across flats	24mm
Standard	JDS121
Thread	16mm
Length	45mm
Grade	10.9

NOTE: The following procedures apply to both right and left-hand sides.

1. Park machine safely.
2. Install mounting frame (C) as shown.
3. Fasten using eight washers (B) and four M16 x 45 hex head cap screws (A).
4. Tighten mounting hardware and torque to specification.
5. Repeat on opposite side.

Specification

M16 x 45 Hex Head Cap
Screw—Force..... 275 N·m
(62 lb·ft)

GS25068,0003DE0-19-31JAN18

Operator Station Operation

Enter and Exit Machine



LV29084—UN—16AUG17

A—Step

Use Step

Step (A) is on the left side of machine. Use step for entering and exiting the operator station. Face machine when getting on and off and maintain 3-point contact with steps, handholds, and handrails.

UP00731,00003ED-19-10AUG17

Adjust Seat

1. Sit on seat.

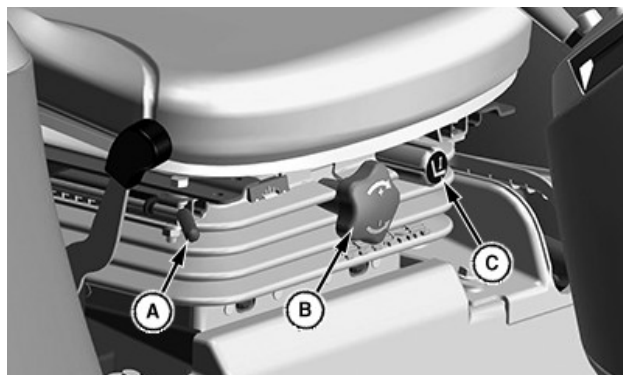

LV29085—UN—16AUG17

A—Seat Lever

2. Pull seat lever (A) sideways to unlock seat position.
3. Slide seat forward or rearward to desired position where all controls can be easily reached.
4. Release lever to lock seat in position.

UP00731,00003EB-19-10AUG17

Use Seat Belt

CAUTION: Avoid injury! Always wear seat belt when operating machine with non-folding Roll-Over Protective Structure (ROPS) or folding ROPS in upright position. Do not jump from machine if machine tips.

If folding ROPS must be folded to operate in a low clearance area, do not use seat belt. Raise ROPS and use seat belt as soon as conditions permit.

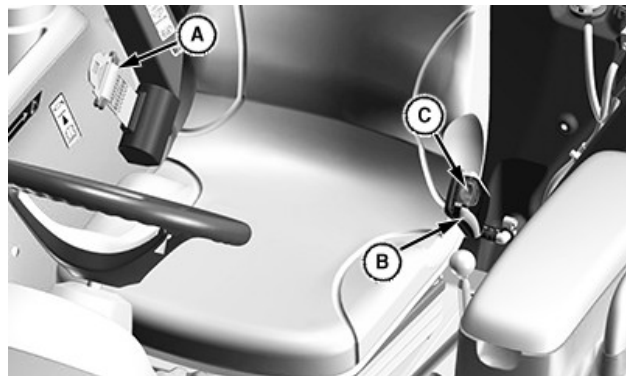

LV29086—UN—16AUG17

A—Seat Belt
B—Latch
C—Seat Belt Release

1. To fasten the seat belt: Extend the self-retracting seat belt (A) and insert it into latch (B) on the opposite side of the seat. The seat belt is self-retracting and it automatically adjusts to fit the operator.
2. To release the seat belt: Press the seat belt release (C) on the buckle.

UP00731,00003EC-19-10AUG17

Roll Over Protection Structure (ROPS)

CAUTION: Avoid injury! Always wear seat belt when operating machine with folding roll-over protective structure (ROPS) in upright position. Do not jump from machine if machine tips.

If ROPS must be folded to operate in a low clearance area, do not use seat belt. Raise ROPS and use seat belt as soon as conditions permit.

CAUTION: If canopy or sunshade is attached to the ROPS structure, the weight MUST be limited to 100 lb (45 kg) or less.

ROPS

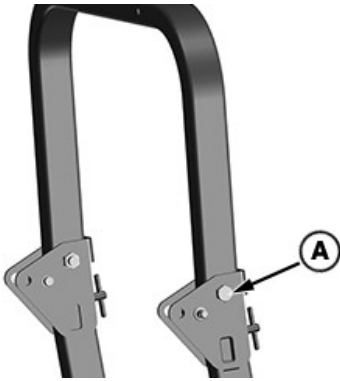

LV30293—UN—04SEP18

A—Bolt

The ROPS on this tractor is equipped with a bolt (A) and nut to keep the structure in an upright position.

2. Remove spring locking pin (A) and drilled pin (B) on each side of the ROPS.
3. Install drilled pins (B) and spring locking pins (A) and lower crossbar (C) onto drilled pins (B).

Raising ROPS Crossbar

1. Carefully raise ROPS crossbar (C) to the operating position.
2. Align crossbar bracket holes with support bracket holes on each side of the ROPS.
3. Install drilled pins (B) and spring locking pins (A) to lock crossbar (C) in the raised position.
4. Tighten anti-rattle t-handle (D). Repeat for other side of ROPS.

UP00731,00005B8-19-21AUG18

Folding ROPS (If equipped)

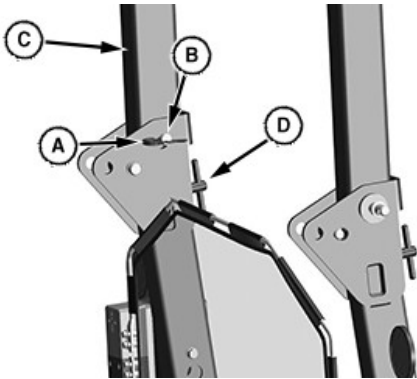

LV29451—UN—22SEP17

ROPS Upright Position

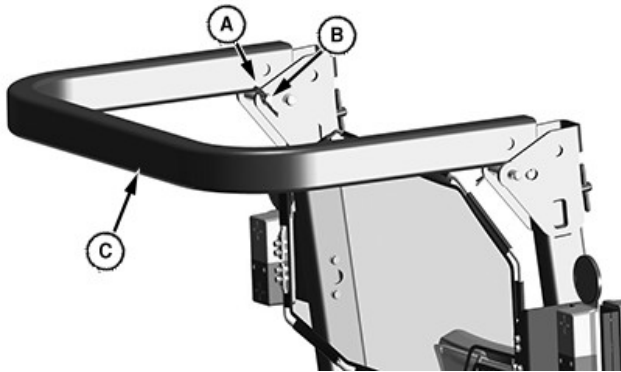

LV29452—UN—22SEP17

ROPS Folded Position

- A—Spring Locking Pin
- B—Drilled Pin
- C—ROPS Crossbar
- D—Anti-Rattle T-Handle

Lowering ROPS Crossbar

1. Turn anti-rattle t-handle (D) counterclockwise to relieve tension.

Using Horn

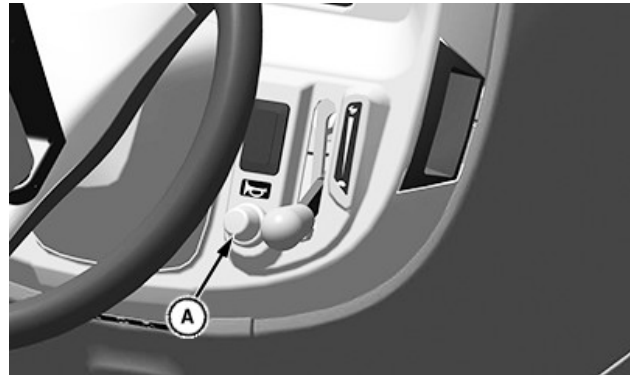

LV29077—UN—02OCT17

A—Horn Switch

To operate horn, press horn switch (A).

UP00731,00003E9-19-10AUG17

Transport and Storage

Transport Machine on Trailer

⚠ CAUTION: Avoid injury! Use extra care when loading or unloading the machine into a trailer or truck.

Close fuel shutoff valve, if the machine is equipped.

IMPORTANT: Avoid damage! Transporting a machine on a trailer at high speeds can result in hood raising and possibly coming off machine if not secured.

- Position machine on trailer so hood or engine cover opens from rear of trailer to prevent wind from blowing hood or cover open.
- Secure hood with existing machine locks or latches.
- If no locks or latches exist, secure hood with tie-down straps.

NOTE: Use a heavy-duty trailer to transport the machine.

1. Drive or back machine onto trailer so hood or engine cover opens from rear of trailer.
2. Lower any implements to the trailer deck.
3. Lock the park brake.
4. Stop the engine.
5. Remove the key.
6. Close the fuel shutoff valve.
7. Remove or cover up the slow moving vehicle (SMV) sign.
8. Fasten machine to trailer with heavy-duty straps, chains, or cables. Both front and rear straps must be directed down and outward from machine. Trailer must have signs and lights as required by law.

SK35149,000116C-19-20JUL17

Transport Machine

Drive Machine Safely on Roads

⚠ CAUTION: Avoid injury! Use caution when operating machine at transport speeds. Reduce speeds if towed load weighs more than machine. Consult towed equipment operator's manual for recommended transport speeds.

Use additional caution when transporting towed loads under adverse surface conditions, especially when turning, and on inclined surfaces.

Use of warning lights and turn signals are recommended when traveling on public roads unless prohibited by state or local regulations. An implement safety lighting kit is available from your John Deere dealer.

Observe the following precautions when operating the machine on a road:

- Make sure SMV (Slow Moving Vehicle) emblem and warning lights are clean and visible. If towed or rear-mounted equipment obstructs these safety devices, install SMV emblem and warning lights on equipment.
- Turn on flashing warning lights and headlights, except if prohibited by law.
- Drive slowly enough to maintain safe control at all times. Slow down for hillsides, rough ground, and sharp turns, especially when transporting heavy, rear-mounted implements.
- Adjust tread width position of rear wheels to provide maximum stability.
- If equipped, disengage the MFWD to reduce tire wear.
- Never coast machine downhill.

SK35149,000116D-19-20JUL17

Push or Tow Machine

⚠ CAUTION: Avoid injury! Never tow machine faster than 10 km/h (6 mph). If possible, have someone operate steering and brakes of towed tractor.

IMPORTANT: Avoid damage! Push or tow machine for short distances only.

1. Push the PTO switch to the disengaged/off position.
2. Disengage the differential lock.
3. Disengage park brake.
4. Move the transmission range-shift lever to the N (neutral) position.
5. Disengage the MFWD.

SK35149,000116E-19-13NOV19

Tow Loads

⚠ CAUTION: Avoid injury! Stopping distance increases with speed and weight of towed load, and on slopes. Towed loads with or without brakes that are too heavy for the machine or are towed too fast can cause loss of control. Consider the weight of the equipment and its load.

Observe these recommended maximum road speeds, or local speed limits if they are lower:

- If towed equipment does not have brakes, do not travel more than 32 km/h (20 mph) and do not tow loads more than 1.5 times the tractor weight.
- If towed equipment has brakes, do not travel more than 40 km/h (25 mph) and do not tow loads more than 4.5 times the machine weight.

Ensure that the load does not exceed the recommended weight ratio. Add ballast to recommended maximum for machine, lighten the load, or get a heavier towing unit. The tractor must be heavy and powerful enough with adequate braking power for the towed load. Use additional caution when towing loads under adverse surface conditions, when turning, and on inclines.

NOTE: Weight requirement for towed equipment:

- If towed equipment does not have brakes, do not tow loads more than 1500 kg (3307 lb) maximum.
- If towed equipment has brakes, do not tow loads more than 2000 kg (4409 lb) maximum.

1. Hitch the towed load only to the rear hitch plate.
2. Connect safety chains to the lower draft arm crossbar and to the towed load. Provide only enough slack to permit turning.
3. Before descending a hill, shift to a gear low enough to control the machine travel speed without having to use the brake pedal to brake the machine and installed implements.

SK35149,000116F-19-10AUG17

Store Safety

⚠ CAUTION: Avoid injury! Fuel vapors are explosive and flammable. Engine exhaust contains carbon monoxide and cause serious illness or death:

- Run the engine only long enough to move the machine to or from storage.

- Do not store vehicle with fuel in the tank inside a building where fumes may reach an open flame or spark.
- Allow the engine to cool before storing the machine in any enclosure.

SK35149,0001171-19-20JUL17

Prepare Machine for Storage

1. Repair any worn or damaged parts. Replace parts if necessary. Tighten loose hardware.
2. Repair scratched or chipped metal surfaces to prevent rust.
3. Wash the machine and apply wax to metal and plastic surfaces.
4. Run machine for five minutes to dry belts and pulleys.
5. Apply light coat of engine oil to pivot and wear points to prevent rust.
6. Lubricate grease points.
7. Check tire pressure.

SK35149,0001172-19-20JUL17

Prepare Fuel and Engine for Storage

Fuel:

If you have been using stabilized fuel, add stabilized fuel to the tank until the tank is full.

NOTE: Filling the fuel tank reduces the amount of air in the fuel tank and helps reduce deterioration of fuel.

If you are not using stabilized fuel:

1. Park machine safely in a well-ventilated area.

NOTE: Try to anticipate the last time the machine is used for the season so little fuel is left in the fuel tank.

2. Turn on engine and allow to run until it runs out of fuel.
3. Turn key to OFF position.

IMPORTANT: Avoid damage! Stale fuel can produce varnish and plug injector components and affect engine performance.

- Add fuel conditioner or stabilizer to fresh fuel before filling tank.
4. Mix fresh fuel and fuel stabilizer in a separate container. Follow stabilizer instructions for mixing.

5. Fill fuel tank with stabilized fuel.
6. Run engine for a few minutes to allow fuel mixture to circulate through the fuel system.
7. Turn key to OFF position.

Engine:

Use engine storage procedure when vehicle is not to be used for longer than 60 days.

1. Change engine oil and filter while engine is warm.
2. Service air filter if necessary.
3. Clean debris from the air intake screen.
4. Clean the engine and engine compartment.
5. Remove the battery.
6. Clean the battery and battery posts.
7. Close fuel shutoff valve, if your machine is equipped.
8. Store the battery in a cool, dry place to avoid freezing.

NOTE: Recharge the stored battery every 90 days.

9. Charge the battery.
10. Store the vehicle in a dry, protected place. If vehicle is stored outside, put a waterproof cover over it.

SK35149,0001173-19-20JUL17

Remove Machine from Storage

1. Check tire pressure.
2. Check engine oil level.
3. Charge battery if necessary.
4. Install battery.
5. Lubricate all grease points.
6. Open fuel shutoff valve, if your machine is equipped.
7. Run the engine 5 minutes without any attachments running to allow oil to be distributed throughout engine.
8. Be sure all shields and guards or deflectors are in place.

SK35149,0001174-19-20JUL17

Battery Isolation / Disconnect

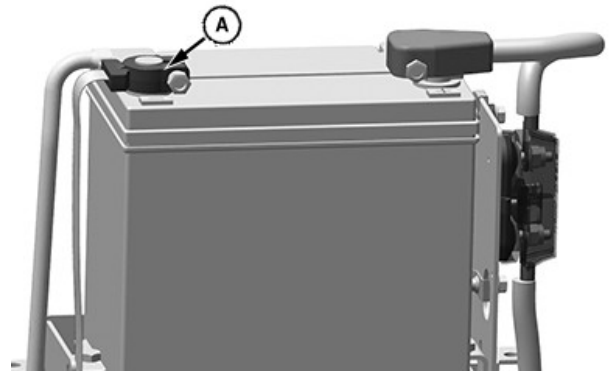

LV29057—UN—31JUL17

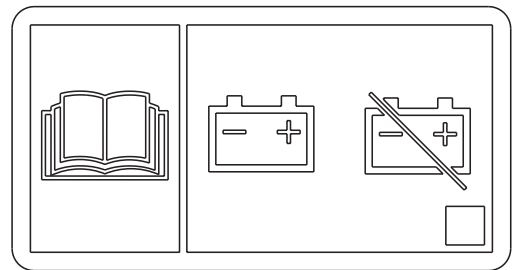

LV26034—UN—26JUL17

A—Black Negative Cable

Disconnect the battery before storing the machine. Read your operator's manual before proceeding.

1. Use a 13mm wrench to disconnect battery cable from terminal.
2. Disconnect black negative (-) cable (A) from battery terminal.
3. Disconnect red positive (+) cable from battery terminal.

UP00731,0000432-19-01SEP17

Maintenance Intervals

Service Your Machine

IMPORTANT: Avoid damage! Operating in extreme conditions require more frequent service intervals:

- Engine components become dirty or plugged when operating in extreme heat, dust, or other severe conditions.
- Engine oil can degrade if machine is

operated constantly at slow or low engine speeds or for frequent short periods of time.

Use the following timetables to perform routine maintenance on your machine.

Park the vehicle safely.

SK35149,00011D2-19-01AUG17

Maintenance Interval Chart—Daily to Every 400 Hours

Item	Daily	Every 10 Hours	Every 50 Hours	Every 200 Hours	Every 400 Hours
Test safety system.	•	•			
Check engine oil level.	•	•			
Check and drain water separator	•				
Check transmission oil level.		•			
Check transmission oil level.	•	•			
Check air filter rubber dust valve.		•			
Check radiator coolant level.	•	•			
Check front grill screen	•				
Check front axle oil level.			•		
Lubricate 3-point hitch.			•		
Change engine oil and filter.					•
Inspect alternator belt.				•	
Check wheel bolt torque.				•	
Change transmission oil and filters. ^a					•
Drain water from fuel tank and replace fuel filter.					•
Lubricate grease points (normal conditions).			•		
Lubricate grease points (wet conditions).		•			

Maintenance Interval Chart — Every 10 Hours to Every 400 Hours

^aTransmission oil can be changed every 1200 hours or 3 years if the specific requirements are met, see Transmission Maintenance for additional information.

UP00731,00009E9-19-11FEB20

Maintenance Interval Chart—Every 600 Hours to Every 6000 Hours

Item	Every 600 Hours	Yearly	Every 1000 Hours	Every 2000 Hours or Annually ^a	Every 6000 Hours/Six Years ^a
Service air filter element and hoses	•				
Change front axle oil	•				
Check axle thrust bolt torque	•				
Change engine oil and filter		•			
Drain water from fuel tank and replace fuel filter		•			
Check all hoses and clamps		•			
Check engine valve clearance. See your John Deere dealer.			•		
Drain, flush and refill engine cooling system ^b when coolant is NOT checked annually or NOT serviced with the pre-diluted John Deere Cool-Gard™. ^c				•	

Maintenance Intervals

Item	Every 600 Hours	Yearly	Every 1000 Hours	Every 2000 Hours or Annually ^a	Every 6000 Hours/Six Years ^a
Drain, flush and refill engine cooling system ^b when coolant is checked annually and serviced with the pre-diluted John Deere Cool-Gard™ II					•

Maintenance Interval Chart — 600 Hours to 6000 Hours

Cool-Gard is a trademark of Deere & Company

^aIf Cool-Gard II is not used and coolant is not tested annually, service interval is 2000 hours/annually

^bSee your John Deere dealer for service.

^cService interval can be extended to six years and 6000 hours thereafter if tractor coolant has been checked annually and serviced with pre-diluted John Deere Cool-Gard II™.

UP00731,000047E-19-13NOV19

Test the Safety Interlock System Before Startup

Test Safety Systems

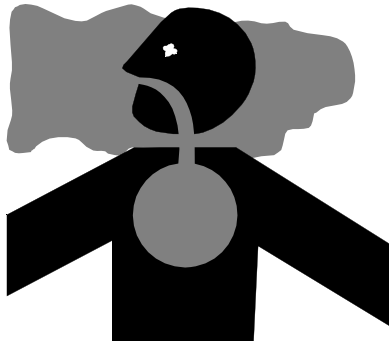

LVAL38264—UN—21AUG12

CAUTION: Avoid Injury! Engine exhaust fumes contain carbon monoxide and can cause serious illness or death.

- Move the machine to an outside area before running the engine.
- Ensure that there is adequate ventilation before running the engine in an enclosed area.
- To direct the exhaust fumes out of the area, connect a pipe extension to the engine exhaust pipe.
- To clear out the exhaust fumes, allow fresh outside air into the work area.

Check the safety systems installed on your machine before each use. Be sure that you have read the machine operator manual and are familiar with the operation of the machine before performing these safety system checks.

Use the following checkout procedures to check for normal operation of machine.

If there is a malfunction during one of these procedures, do not operate machine. See your authorized dealer for service.

Perform these tests in a clear open area. Keep bystanders away.

Test the Neutral Start Switch

1. Sit on the operator seat.
2. Disengage PTO.
3. Move the transmission range lever to the H (high) or L (low) position.
4. Turn key switch to START position.

Result: Engine must not start.

Test the Seat Switch

1. Sit on the operator seat.
2. Do not depress the hydrostatic travel pedals.
3. Lock park brake.
4. Start engine.
5. Press PTO switch.
6. Raise up slightly from the operator seat. Do not dismount machine.

Result: Engine must shut down within 1 second.

Test the Rear PTO Switch

1. Sit on the operator seat.
2. Lock park brake.
3. Move transmission range lever to the N (neutral) position.
4. Press PTO switch to the engaged/on position.
5. Turn key to START position.

Result: Engine must not start.

SK35149,00011D5-19-09AUG17

Avoid Damage to Plastic and Painted Surfaces

- Do not wipe plastic parts unless rinsed first. Using a dry cloth may cause scratches.

- Insect repellent spray may damage plastic and painted surfaces. Do not spray insect repellent near machine.
- Be careful not to spill fuel on machine. Fuel may damage surface. Wipe up spilled fuel immediately.
- Prolonged exposure to sunlight will damage hood surfaces.

SK35149,00011D6-19-01AUG17

Clean Plastic Surfaces

IMPORTANT: Avoid damage! Improper care of machine plastic surfaces can damage that surface:

- **Do not wipe plastic surfaces when they are dry. Dry wiping results in minor surface scratches.**
 - **Use a soft, clean cloth (bath towel, diaper, automotive mitt).**
 - **Do not use abrasive materials, such as polishing compounds, on plastic surfaces.**
1. To remove the dirt and dust that scratches the surface, rinse hood and entire machine with clean water.
 2. Wash surface with clean water and a mild liquid automotive washing soap.
 3. Dry thoroughly to avoid water spots.
 4. Wax the surface with a liquid automotive wax. Use products that specifically say “contains no abrasives.”

IMPORTANT: Avoid damage! Do not use a power buffer to remove wax.

5. Buff applied wax by hand using a clean, soft cloth.

SK35149,00011D7-19-01AUG17

Clean and Repair Metal Surfaces

Clean:

Follow automotive practices to care for your vehicle painted metal surfaces. Use a high-quality automotive wax regularly to maintain the factory look of your vehicle's painted surfaces.

Repair Minor Scratches (surface scratch):

1. Clean area to be repaired thoroughly.

IMPORTANT: Avoid damage! Do not use rubbing compound on painted surfaces.

2. Use automotive polishing compound to remove surface scratches.
3. Apply wax to entire surface.

Repair Deep Scratches (bare metal or primer showing):

1. Clean area to be repaired with rubbing alcohol or mineral spirits.
2. Use paint stick with factory-matched colors available from your authorized dealer to fill scratches. Follow directions included on paint stick for use and for drying.
3. Smooth out surface using an automotive polishing compound. Do not use power buffer.
4. Apply wax to surface.

SK35149,00011D8-19-01AUG17

Fuel, Lubricants, and Coolant

Carbon Dioxide Emissions (CO₂)

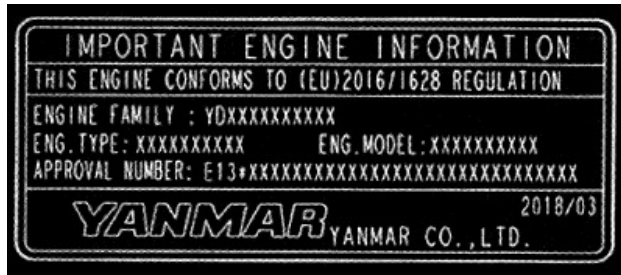

TCT015573—UN—17MAY18

To identify the carbon dioxide (CO₂) output, locate the engine emissions label. Find the appropriate family on the emissions label and reference the chart.

Engine Family	CO ₂ Output
YD099PNLNV2A	1048 g/kWh
YD085PNLNV2A	995 g/kWh
YD112PNLNV2A	932 g/kWh
YD127PNLVN2A	1017 g/kWh
YD164DNMNV2B	839 g/kWh
YD219DNCDV3A	835 g/kWh
YD209DTCDV4A	837 g/kWh
YD209DHCDV4A	756 g/kWh
YD332DNCDV4A	792 g/kWh
YD332DTCDV4A	738 g/kWh
YD305DHCSV5A	732 g/kWh

This CO₂ measurement results from testing over a fixed test cycle under laboratory conditions a(n) (parent) engine representative of the engine type (engine family) and shall not imply or express any guarantee of the performance of a particular engine.

UP00731.0000930-19-24SEP19

Emissions Performance and Tampering

Operation and Maintenance

The engine, including the emissions control system, shall be operated, used, and maintained in accordance with the instructions provided in this manual to maintain the emissions performance of the engine within the requirements applicable to the engine's category/certification.

Tampering

No deliberate tampering with or misuse of the engine emissions control system shall take place; in particular with regard to deactivating or not maintaining an exhaust gas recirculation (EGR) or a DEF dosing system. Tampering with an engine's emissions control system will void the European Union (EU) type approval and applicable emissions-related warranties.

DX,EMISSIONS,PERFORM-19-12JAN18

Diesel Fuel

Use the proper diesel fuel to help prevent decreased engine performance and increased exhaust emissions. Failure to follow the fuel requirements listed below can void your engine warranty.

Consult your local fuel distributor for properties of the diesel fuel in your area.

In general, diesel fuels are blended to satisfy the low temperature requirements of the geographical area in which they are marketed.

Diesel fuels specified to ISO EN 590 or ASTM D975 are recommended.

Required fuel properties

In all cases, the fuel shall meet the following properties:

Cetane number of 45 minimum. Cetane number greater than 50 is preferred, especially when temperatures are below -20°C (-4°F) or elevations above 1500 m (5000 ft).

Cold Filter Plugging Point (CFPP) should be at least 5°C (9°F) below the expected lowest temperature or **Cloud Point** below the lowest ambient temperature.

Fuel lubricity should comply with ISO EN 590 or ASTM D975.

IMPORTANT: Avoid damage! Improper fuel additive usage may cause damage on fuel injection equipment of diesel engines.

If a fuel of low or unknown lubricity is used, addition of John Deere PREMIUM DIESEL FUEL CONDITIONER at the specified concentration is recommended.

Sulfur content

- Diesel fuel quality and fuel sulfur content must comply with all existing emissions regulations for the area in which the engine operates.
- 3025E - Use of diesel fuel with sulfur content less than 0.1% (1000 mg/kg) is required.
- 3038E - Use of diesel fuel with sulfur content less than 0.5% (5000 mg/kg) is required.

IMPORTANT: Avoid injury! Do not mix diesel engine oil or any other type of lubricating oil with diesel fuel.

Using Bio-Diesel Fuel

Bio-diesel fuels may be used only if the bio-diesel fuel properties meet the latest edition of ASTM D6751, ASTM D7467, EN14214, or equivalent specification.

The current maximum allowable bio-diesel concentration is a 8% blend (also known as B8) in petroleum diesel fuel.

To learn of any changes to the recommendations for

bio-diesel usage with your diesel engine, ask your John Deere dealer.

Handling and Storing Diesel Fuel

⚠ CAUTION: Avoid injury! Handle fuel carefully. Do not fill the fuel tank when engine is running.

Do not smoke while you fill the fuel tank or service the fuel system.

IMPORTANT: Avoid damage! Do not use galvanized containers—diesel fuel stored in galvanized containers reacts with zinc coating in the container to form zinc flakes. If fuel contains water, a zinc gel will also form. The gel and flakes will quickly plug fuel filters and damage fuel injectors and fuel pumps.

- Fill the fuel tank at the end of each day's operation to prevent water condensation and freezing during cold weather.
- When fuel is stored for an extended period or if there is a slow turnover of fuel, add a fuel conditioner to stabilize the fuel and to prevent water condensation. Contact your fuel supplier for recommendations.

UP00731,0000A0A-19-03DEC19

Handling and Storing Diesel Fuel

⚠ CAUTION: Reduce the risk of fire. Handle fuel carefully. DO NOT fill the fuel tank when engine is running. DO NOT smoke while you fill the fuel tank or service the fuel system.

Fill the fuel tank at the end of each day's operation to prevent water condensation and freezing during cold weather.

Keep all storage tanks as full as practical to minimize condensation.

Ensure that all fuel tank caps and covers are installed properly to prevent moisture from entering. Monitor water content of the fuel regularly.

When using biodiesel fuel, the fuel filter may require more frequent replacement due to premature plugging.

Check engine oil level daily prior to starting engine. A rising oil level may indicate fuel dilution of the engine oil.

IMPORTANT: The fuel tank is vented through the filler cap. If a new filler cap is required, always replace it with an original vented cap.

When fuel is stored for an extended period or if there is a slow turnover of fuel, add a fuel conditioner to stabilize the fuel. Keeping the free water drained and treating the bulk fuel storage tank quarterly with a maintenance

dose of a biocide will prevent microbial growth. Contact your fuel supplier or John Deere dealer for recommendations.

DX,FUEL4-19-13JAN18

Testing Diesel Fuel

A fuel analysis program can help to monitor the quality of diesel fuel. The fuel analysis can provide critical data such as calculated cetane index, fuel type, sulfur content, water content, appearance, suitability for cold weather operations, bacteria, cloud point, acid number, particulate contamination, and whether the fuel meets ASTM D975 or equivalent specification.

Contact your John Deere dealer for more information on diesel fuel analysis.

DX,FUEL6-19-13JAN18

Minimizing the Effect of Cold Weather on Diesel Engines

John Deere diesel engines are designed to operate effectively in cold weather.

However, for effective starting and cold-weather operation, a little extra care is necessary. The following information outlines steps that can minimize the effect that cold weather may have on starting and operation of your engine. See your John Deere dealer for additional information and local availability of cold-weather aids.

Use Winter Grade Fuel

When temperatures fall below 0°C (32°F), winter grade fuel (No. 1-D in North America) is best suited for cold-weather operation. Winter grade fuel has a lower cloud point and a lower pour point.

Cloud point is the temperature at which wax begins to form in the fuel. This wax causes fuel filters to plug.

Pour point is the lowest temperature at which movement of the fuel is observed.

NOTE: On average, winter grade diesel fuel has a lower Btu (heat content) rating. Using winter grade fuel may reduce power and fuel efficiency, but should not cause any other engine performance effects. Check the grade of fuel being used before troubleshooting for low-power complaints in cold-weather operation.

Air Intake Heater

An air intake heater is an available option for some engines to aid cold weather starting.

Coolant Heater

An engine block heater (coolant heater) is an available option to aid cold weather starting.

Seasonal Viscosity Oil and Proper Coolant Concentration

Use seasonal grade viscosity engine oil based on the expected air temperature range between oil changes and a proper concentration of low silicate antifreeze as recommended. (See DIESEL ENGINE OIL and ENGINE COOLANT requirements in this section.)

Diesel Fuel Cold Flow Additive

Use John Deere Fuel-Protect Diesel Fuel Conditioner (winter formula), which contains anti-gel chemistry, or equivalent fuel conditioner to treat non-winter grade fuel (No. 2-D in North America) during the cold-weather season. This generally extends operability to about 10° C (18°F) below the fuel cloud point. For operability at even lower temperatures, use winter grade fuel.

IMPORTANT: Treat fuel when outside temperature drops below 0°C (32°F). For best results, use with untreated fuel. Follow all recommended instructions on label.

Biodiesel

When operating with biodiesel blends, wax formation can occur at warmer temperatures. Begin using John Deere Fuel-Protect Diesel Fuel Conditioner (winter formula) or equivalent at 5°C (41°F) to treat biodiesel fuels during the cold-weather season. Use B5 or lower blends at temperatures below 0°C (32°F). Use only winter grade petroleum diesel fuel at temperatures below -10°C (14°F).

Winterfronts

Use of fabric, cardboard, or solid winterfronts is not recommended with any John Deere engine. Their use can result in excessive engine coolant, oil, and charge air temperatures. This can lead to reduced engine life, loss of power and poor fuel economy. Winterfronts may also put abnormal stress on fan and fan drive components potentially causing premature failures.

If winterfronts are used, they should never totally close off the grill frontal area. Approximately 25% area in the center of the grill should remain open at all times. At no time should the air blockage device be applied directly to the radiator core.

Radiator Shutters

If equipped with a thermostatically controlled radiator shutter system, this system should be regulated in such a way that the shutters are completely open by the time the coolant reaches 93°C (200°F) to prevent excessive intake manifold temperatures. Manually controlled systems are not recommended.

If air-to-air aftercooling is used, the shutters must be completely open by the time the intake manifold air temperature reaches the maximum allowable temperature out of the charge air cooler.

For more information, see your John Deere dealer.

JC48530,00000AA-19-02OCT19

Alternative and Synthetic Lubricants

Conditions in certain geographical areas may require lubricant recommendations different from those printed in this manual.

Some John Deere brand coolants and lubricants may not be available in your location.

Consult your John Deere dealer to obtain information and recommendations.

Synthetic lubricants may be used if they meet the performance requirements as shown in this manual.

The temperature limits and service intervals shown in this manual apply to John Deere branded fluids or fluids that have been tested and/or approved for use in John Deere equipment.

Re-refined base stock products may be used if the finished lubricant meets the performance requirements.

DX,ALTER-19-13JAN18

Engine Oil

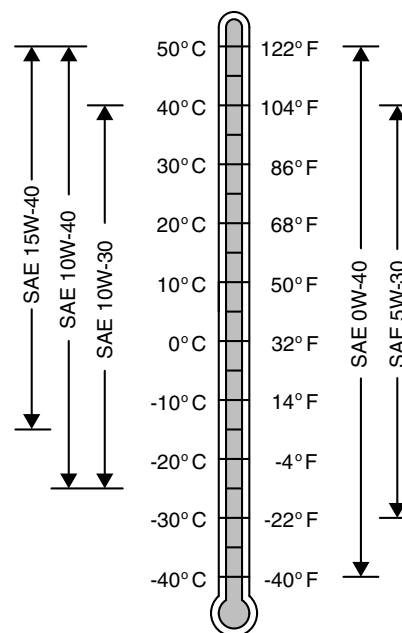

TS1691—UN—18JUL07

Oil Viscosities for Air Temperature Ranges

Use oil viscosity based on the expected air temperature range during the period between oil changes.

The following John Deere oils are preferred:

- Plus-50™ II

Plus-50 is a trademark of Deere & Company

- Torq-Gard™ Supreme

Other oils may be used if above John Deere oils are not available, provided they meet the following specification:

- API Service Classification CD, CF, CF—4, CI—4, CJ—4 or CK—4
- ACEA Specification E—3, E—4, E—5 or E—6
- JASO Specification DH—1 or DH—2

Diesel fuel quality and fuel sulfur content must comply with all existing emissions regulations for the area in which the engine operates.

KN52281,1004A5F-19-03DEC19

Diesel Engine Coolant

Preferred coolants:

The following pre-mix engine coolants are preferred:

- John Deere Cool-Gard™ II
- John Deere Cool-Gard™ II PG

Not all Cool-Gard™ II pre-mix products are available in all countries.

Use Cool-Gard™ II PG when a non-toxic coolant formulation is required.

Additional Recommended Coolants

The following engine coolant is also recommended:

- John Deere Cool-Gard™ II Concentrate in a 40—60% mixture of concentrate with quality water.

IMPORTANT: Avoid damage! When mixing coolant concentrate with water, do not use less than 40% or greater than 60% concentration of coolant. Less than 40% gives inadequate additives for corrosion protection. Greater than 60% can result in coolant gelation and cooling system problems.

Other Coolants

Other ethylene glycol or propylene glycol base coolants may be used if they meet one of the following specifications:

- Pre-mix coolant meeting ASTM D6210 requirements
- Coolant concentrates meeting ASTM D6210 requirements in a 40% to 60% mixture of concentrate with quality water
- Pre-mix coolant meeting ASTM D3306 requirements
- Coolant concentrates meeting ASTM D3306

requirements in a 40% to 60% mixture of concentrate with quality water

If coolant meeting one of these specifications is unavailable, use a coolant concentrate or pre-mix coolant that has a minimum of the following chemical and physical properties:

- Is formulated with a quality nitrite-free additive package.
- Protects the cooling system metals (cast iron, aluminum alloys, and copper alloys such as brass) from corrosion.

Water Quality

Water quality is important to the performance of the cooling system. Distilled, deionized, or demineralized water is recommended for mixing with ethylene glycol base engine coolant concentrate.

Coolant Drain Intervals

Drain and flush the cooling system and refill with fresh coolant at the indicated interval, which varies with the coolant used.

When Cool-Gard™ II or Cool-Gard™ II PG is used, the drain interval is 6 years or 6000 operating hours.

If a coolant other than Cool-Gard™ II or Cool-Gard™ II PG is used, reduce the drain interval to 2 years or 2000 operating hours.

IMPORTANT: Avoid Damage!

- Do not use cooling system sealing additives or antifreeze that contains sealing additives.
- Do not mix ethylene glycol and propylene glycol base coolants.
- Do not use coolants that contain nitrites.

UP00731,0000022-19-17JAN19

Operating in Warm Temperature Climates

John Deere engines are designed to operate using recommended engine coolants.

Always use a recommended engine coolant, even when operating in geographical areas where freeze protection is not required.

IMPORTANT: Water may be used as coolant in emergency situations only.

Foaming, hot surface aluminum and iron corrosion, scaling, and cavitation occur when water is used as the coolant, even when coolant conditioners are added.

Torq-Gard is a trademark of Deere & Company
Cool-Gard is a trademark of Deere & Company

Drain cooling system and refill with recommended engine coolant as soon as possible.

DX,COOL6-19-17FEB20

Additional Information About Diesel Engine Coolants and John Deere COOL-GARD™ II Coolant Extender

Engine coolants are a combination of three chemical components: ethylene glycol (EG) or propylene glycol (PG) antifreeze, inhibiting coolant additives, and quality water.

Coolant Specifications

John Deere COOL-GARD™ II Premix either EG or PG, are fully formulated coolants that contain all three components in their correct concentrations. DO NOT add an initial charge of John Deere COOL-GARD II Coolant Extender to COOL-GARD II Premix. DO NOT add any other supplemental coolant additive or water to COOL-GARD II Premix.

John Deere COOL-GARD II Concentrate contains both ethylene glycol and inhibiting coolant additives. Mix this product with quality water, but DO NOT add an initial charge of John Deere COOL-GARD II Coolant Extender or any other supplemental coolant additive.

Replenish Coolant Additives

Some coolant additives will gradually deplete during engine operation. Periodic replenishment of inhibitors is required, even when John Deere COOL-GARD II Premix or COOL-GARD II Concentrate is used. Follow the recommendations in this manual for the use of John Deere COOL-GARD II Coolant Extender.

Why use John Deere COOL-GARD II Coolant Extender?

Operating without proper coolant additives will result in increased corrosion, cylinder liner erosion and pitting, and other damage to the engine and cooling system. A simple mixture of ethylene glycol or propylene glycol and water will not give adequate protection.

John Deere COOL-GARD II Coolant Extender is a chemically matched additive system designed to fortify the proprietary additives used in John Deere COOL-GARD II Premix and COOL-GARD II Concentrate and to provide optimum protection for up to six years or 6000 hours of operation.

Avoid Automotive-type Coolants

Never use automotive-type coolants (such as those meeting ASTM D3306). These coolants do not contain the correct additives to protect heavy-duty diesel engines. Do not treat an automotive engine coolant with

supplemental coolant additives because the high concentration of additives can result in additive fallout.

Water Quality

Water quality is important to the performance of the cooling system. Distilled, deionized, or demineralized water is recommended for mixing with ethylene glycol and propylene glycol base engine coolant concentrate. All water used in the cooling system should meet the following minimum specifications for quality:

Chlorides	<40 mg/L
Sulfates	<100 mg/L
Total dissolved solids	<340 mg/L
Total hardness	<170 mg/L
pH	5.5 to 9.0

Freeze Protection

The relative concentrations of glycol and water in the engine coolant determine its freeze protection limit.

Ethylene Glycol	Freeze Protection Limit
40%	-24°C (-12°F)
50%	-37°C (-34°F)
60%	-52°C (-62°F)
Propylene Glycol	Freeze Protection Limit
40%	-21°C (-6°F)
50%	-33°C (-27°F)
60%	-49°C (-56°F)

DO NOT use a coolant-water mixture greater than 60% ethylene glycol or 60% propylene glycol.

DX,COOL17-19-20APR11

Testing Diesel Engine Coolant

Maintaining adequate concentrations of glycol and inhibiting additives in the coolant is critical to protect the engine and cooling system against freezing, corrosion, and cylinder liner erosion and pitting.

Test the coolant solution at intervals of 12 months or less and whenever excessive coolant is lost through leaks or overheating.

Coolant Test Strips

Coolant test strips are available from your John Deere dealer. These test strips provide a simple, effective method to check the freeze point and additive levels of your engine coolant.

When Using John Deere COOL-GARD II

John Deere COOL-GARD II Premix™, COOL-GARD II PG Premix and COOL-GARD II Concentrate are maintenance free coolants for up to six years or 6000

hours of operation, provided that the cooling system is topped off using only John Deere COOL-GARD II Premix or COOL-GARD II PG premix. Test the coolant condition annually with coolant test strips designed for use with John Deere COOL-GARD II coolants. If the test strip chart indicates that additive is required, add John Deere COOL-GARD II Coolant Extender as directed.

Add only the recommended concentration of John Deere COOL-GARD II Coolant Extender. DO NOT add more than the recommended amount.

When Using Nitrite-Containing Coolants

Compare the test strip results to the supplemental coolant additive (SCA) chart to determine the amount of inhibiting additives in your coolant and whether more John Deere Liquid Coolant Conditioner should be added.

Add only the recommended concentration of John Deere Liquid Coolant Conditioner. DO NOT add more than the recommended amount.

Coolant Analysis

For a more thorough evaluation of your coolant, perform a coolant analysis. The coolant analysis can provide critical data such as freezing point, antifreeze level, pH, alkalinity, nitrite content (cavitation control additive), molybdate content (rust inhibitor additive), silicate content, corrosion metals, and visual assessment.

Contact your John Deere dealer for more information on coolant analysis.

DX,COOL9-19-11APR11

Transmission and Hydraulic Oil

IMPORTANT: Avoid damage! Transaxle is filled with John Deere Hy-Gard™ (J20D) transmission oil at the factory. DO NOT mix oils.

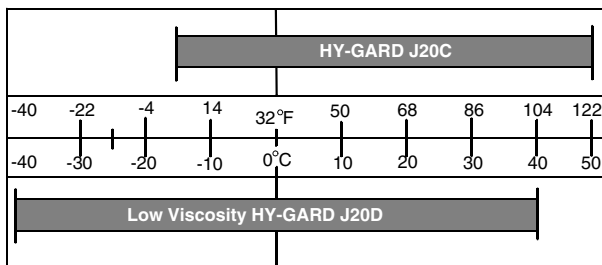

LVAL38329—UN—21AUG12

Do not use type “F” automatic transmission fluid.

Use Low Viscosity Hy-Gard (J20D) transmission oil.

John Deere Low Viscosity Hy-Gard transmission oil is specially formulated for operation below -18°C (0)°F to provide maximum protection for the hydraulic system.

Hy-Gard is a trademark of Deere & Company

Use oil viscosity based on the expected air temperature range during the period between oil changes.

IMPORTANT: Avoid damage! Use recommended oil only. Do not use engine oil or “Type F” automatic transmission fluid.

Other oils may be used if they meet John Deere standard JDM J20D or J20C.

SK35149,00011F4-19-10AUG17

Front Axle and MFWD Oil

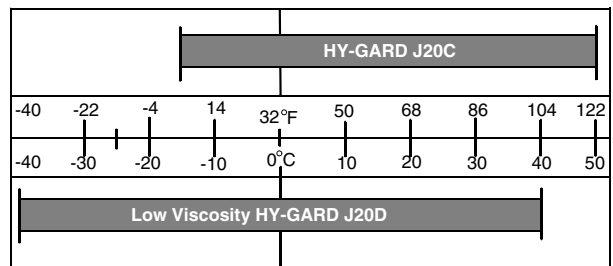

LVAL38329—UN—21AUG12

Use oil viscosity based on the expected air temperature range during the period between oil changes.

The following oils are preferred:

- John Deere Hy-Gard™
- John Deere Low Viscosity Hy-Gard™

Other oils may be used if they meet one of the following:

- John Deere Standard JDM J20C
- John Deere Standard JDM J20D

SK35149,00011F5-19-10AUG17

Maintenance—As Required

Service—As Required

- Replace alternator belt.
- Replace air filter elements.
- Inspect air intake system hoses and connections each time the air filter is changed.
- Replace light bulbs.
- Replace fuses.
- Clean and replace battery.
- Replace radiator hoses and clamps.
- Check tire air pressure.
- Check engine coolant level. Refill with correct coolant and conditioner as required.
- Clean fuel tank overfill reservoir.
- Check and clean radiator fins.
- Drain water and sediment from fuel sediment bowl, and service water separator.
- Check and clean front grille and side screens.
- Check and adjust front wheel toe-in.
- Check and clean radiator cooling screen.
- Clean debris from engine compartment.

UP00731,0000413-19-29SEP17

Controls and Instruments Maintenance

Controls and Instruments Maintenance

For controls and instruments maintenance, see specific component in maintenance section.

SK35149,00011D1-19-01AUG17

Engine Maintenance

Required Emission-Related Information

Service Provider

A qualified repair shop or person of the owner's choosing may maintain, replace, or repair emission control devices and systems with original or equivalent replacement parts. However, warranty, recall, and all other services paid for by John Deere must be performed at an authorized John Deere service center.

DX,EMISSIONS,REQINFO-19-12JUN15

Daily Startup Procedure

- Test safety systems. Perform safety interlock system checkout procedure.
- Check engine oil level.
- Check / drain water separator.
- Check transmission fluid level.
- Check coolant level.
- Clean air intake screen and radiator screen.
- Check air filter elements and dust valve.
- Check wheel bolt torques.
- Check tire pressure.
- Check fuel level.
- Remove grass and debris from machine.
- Check area below the machine for leaks.

CM74493,00000E4-19-29JAN18

Check Engine Oil Level

IMPORTANT: Avoid damage! Failure to check the oil level regularly could lead to a serious engine problem:

- Check oil level before operating.
- Check oil level when the engine is cold and not running.
- Keep level between the Full and the Add marks.
- Shut off engine before adding oil.

NOTE: Check engine oil when engine is cold. If engine is warm, allow to cool for at least 5 minutes before checking oil.

Check engine oil with the machine parked on a level surface.

1. Park the machine safely.

IMPORTANT: Avoid damage! Dirt and contamination can enter engine when checking oil level. Clean area around dipstick before loosening or removing.

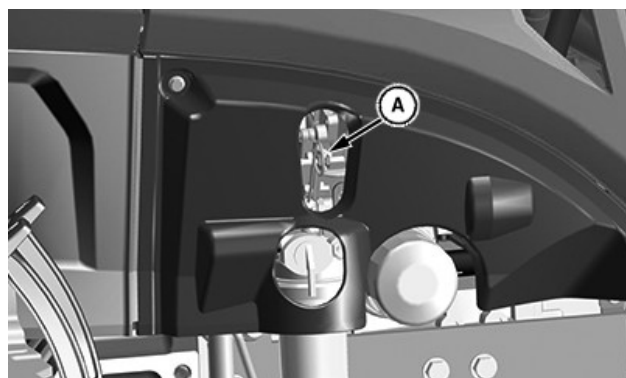

LV29087—UN—16AUG17

A—Dipstick

2. Remove dipstick (A), at the right side of the engine. Wipe with a clean cloth.
3. Install dipstick.
4. Remove dipstick.

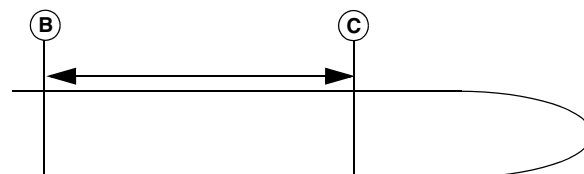

LVAL38308—UN—21AUG12

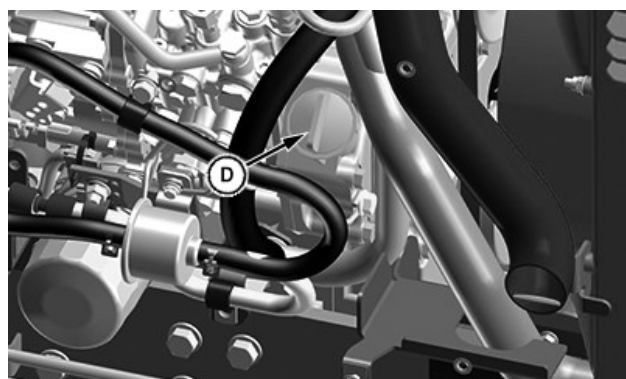

LV29088—UN—16AUG17

B—Oil Level
C—Oil Level
D—Oil Fill Cap

5. Check oil level on dipstick. Oil level should be between levels (B) and (C) on dipstick.

6. If oil level is low:
 - a. Raise hood.
 - b. Remove right side panel.
 - c. Remove oil fill cap (D).
 - d. Add recommended engine oil until level is within operating range on dipstick. Do not overfill.
 - e. Install dipstick.
7. If oil is above LEVEL (B) on dipstick, drain to the proper level.
8. Install right side panel.
9. Lower hood.

UP00731,00003F3-19-10AUG17

14. Stop engine. Fix any leaks before operating.
15. Check engine oil level. Add oil if necessary.

UP00731,00003F4-19-11NOV19

Clean Dust Unloading Valve

IMPORTANT: Avoid damage! Ensure air cleaner element and rubber dust unloading valve are installed before operating the engine.

1. Park the machine safely.
2. Allow engine to cool.
3. Access the engine compartment.

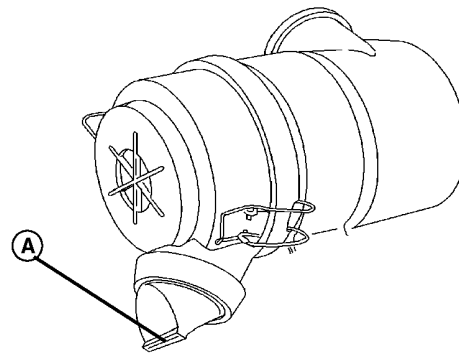

LVAL38312—UN—21AUG12

A—Dust Unloading Valve

4. Squeeze dust unloading valve (A) to clean. Remove and replace if damaged.

SK35149,00011E8-19-01AUG17

Change Engine Oil and Filter



LV29089—UN—16AUG17

A—Oil Drain Plug
B—Oil Filter
C—Oil Fill Cap

1. To warm the oil, run engine.
2. Park machine safely.
3. Place drain pan under the oil drain plug (A).
4. Remove drain plug.
5. Wipe dirt from around the oil filter (B).
6. Turn filter counterclockwise to remove.
7. Put a light coat of clean engine oil on gasket of the new filter.
8. Install replacement oil filter by turning filter clockwise until gasket contacts filter base. Tighten additional one half turn.
9. Install drain plug. Do not overtighten.
10. Remove oil fill cap (C).
11. Add engine oil according to specifications.
12. Install oil fill cap.
13. Start and run engine at idle to check for leaks.

Service the Alternator Belt

⚠ CAUTION: Avoid injury! Rotating parts can catch fingers, loose clothing, or long hair. Wait for engine and all moving parts to stop before leaving the operator station to adjust or service machine.

NOTE: This procedure requires a John Deere belt tension gauge, or equivalent.

Check Belt Tension

1. Park machine safely. Allow engine to cool.
2. Raise hood.
3. Remove left side panel.

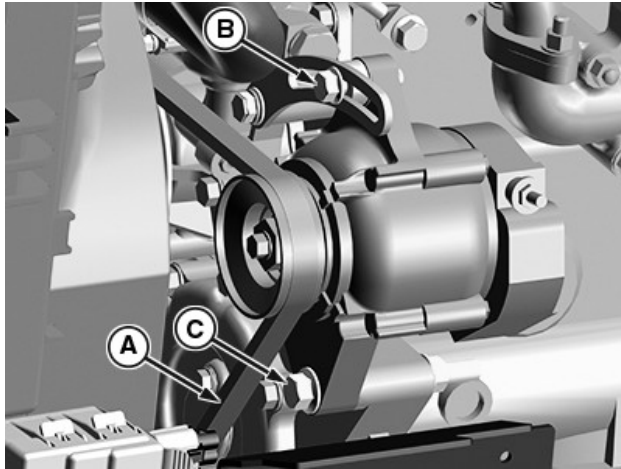

PY38975—UN—17JUL17

A—Belt Deflection Location
B—Adjusting Bolt
C—Pivot Bolt

4. Check tension by using the belt tension gauge to apply pressure to the belt midway between pulleys at location (A).
5. Adjust belt tension if not within specifications.

Specification

Belt Tension—Force. 75 lb (334 N)
Belt Tension—Inward Pressure. 9 mm (3/8 in)

Adjust Belt Tension

1. Loosen adjusting bolt (B) and pivot bolt (C).
2. Apply outward pressure to the alternator housing until tension is correct.
3. Tighten bolts (B) and (C).
4. Check belt tension.
5. Install left side panel.
6. Lower hood.

Replace Belt

NOTE: Replace alternator belt if excessive wear, damage, or stretching is detected.

1. Park machine safely. Allow engine to cool.
2. Raise hood.
3. Remove left side panel.
4. Loosen adjusting bolt (B) and pivot bolt (C).
5. Apply inward pressure to the alternator housing.
6. Remove belt from alternator pulley, fan pulley, and crankshaft pulley.
7. Route belt over fan and remove.
8. Install new belt over the fan and onto pulleys.

9. Apply outward pressure to the alternator housing until tension is correct.
10. Tighten bolts (B) and (C).
11. Check belt tension. Adjust as necessary.
12. Install left side panel.
13. Lower hood.

SK35149,00011E9-19-01AUG17

Clean Front and Side Grille Screens

IMPORTANT: Avoid damage! Grille and side screens must be clean to prevent engine from overheating and to allow adequate air intake.

1. Park machine safely.
2. Check front and side grille screens for dirt, grass clippings, and debris.
3. Raise hood and clean screens with a brush or cloth.
4. Lower hood.

SK35149,00011EA-19-01AUG17

Clean Engine Compartment

Keep all the dirt and debris cleaned from inside of the engine compartment.

1. Park machine safely.
2. Clean all the dirt and debris from inside of the engine compartment.

SK35149,00011EB-19-01AUG17

Air, Fuel, Coolant, and Exhaust Maintenance

Service Air Filter Elements

CAUTION: Avoid injury! Touching hot surfaces can burn skin. The engine, components, and fluids are hot if the engine has been running. Allow the engine to cool before servicing or working near the engine and components.

IMPORTANT: Avoid damage! Dirt and debris can enter the engine through a damaged filter element.

Service Primary Air Filter Element:

NOTE: Procedure shown for 3025E, it is similar for other models.

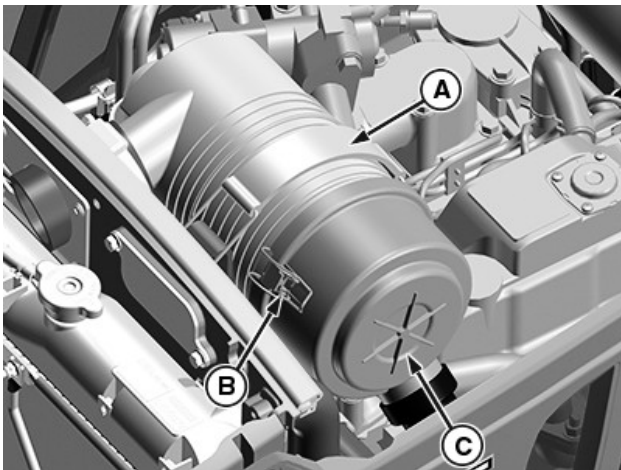

PY38976—UN—17JUL17

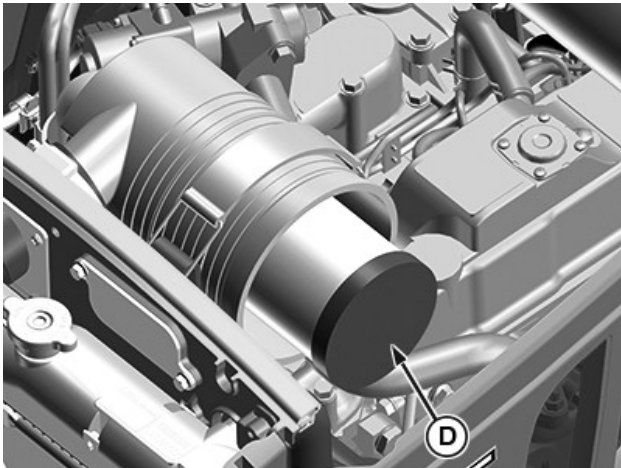

PY38977—UN—17JUL17

A—Hold Down Strap
B—Latch
C—Air Filter Canister Cover
D—Primary Element

1. Park machine safely.
2. Allow engine to cool.
3. Raise hood.
4. Remove hold down strap (A).

5. Tilt up canister and release latches (B) and remove canister cover (C).
6. Remove and discard primary element (D). Clean out any dirt in canister, taking care not to damage secondary filter element. Replace with a new primary filter element.
7. Install canister cover with rubber dust unloading valve pointing downward.
8. Secure latches.
9. Lower hood.

Service Secondary Air Filter Element:

IMPORTANT: Avoid damage! Secondary element does not need routine replacement. Visually inspect it without removing from canister. Do not attempt to clean secondary element. If secondary element is replaced, install new primary and secondary element immediately to prevent dust from entering the air intake system.

1. Remove canister cover.
2. Remove and discard primary air filter element.

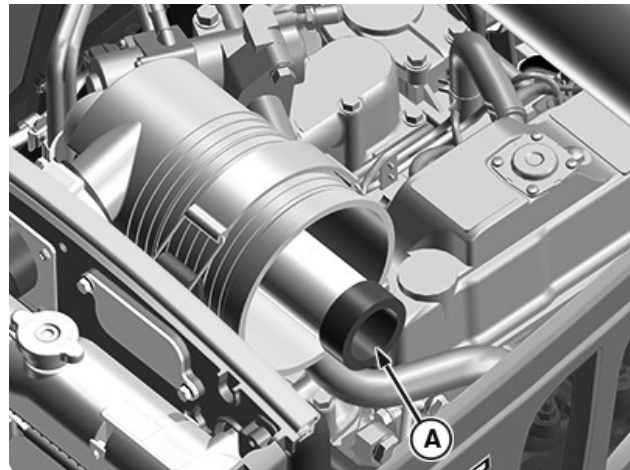

PY38978—UN—17JUL17

A—Secondary Element

3. Remove and discard secondary air filter element (A). Replace with a new secondary air filter element.
4. Install new primary air filter element.
5. Install canister cover.
6. Position canister back in place and install strap.
7. Lower hood.

SK35149,00011B9-19-10AUG17

Check Air Filter Hose

NOTE: Inspect air intake system hoses and connections each time the air filter is changed, or at a minimum yearly.

1. Park machine safely.
2. Raise hood.

NOTE: Visually inspect hose for cracks and wear. Squeeze hose to check for deterioration. Hose should not be hard and brittle, nor soft or swollen.

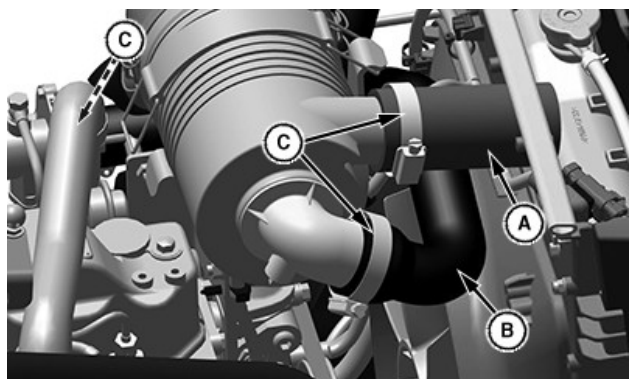

A—Air Intake Hose
B—Air Filter Hose
C—Hose Clamp

LV29090—UN—16AUG17

3. Check air intake hose (A) and air filter hose (B).
4. Tighten hose clamps (C) if necessary.
5. Lower hood.

UP00731.00003F5-19-10AUG17

Checking and Cleaning Fuel Filter Sediment Bowl and Replacing Filter

CAUTION: Avoid injury! Fuel vapors are explosive and flammable:

- Do not smoke while handling fuel.
- Keep fuel away from flames or sparks.
- Shut off engine before servicing.
- Cool engine before servicing.
- Work in a well-ventilated area.
- Clean up spilled fuel immediately.

NOTE: Change filter when fuel level is low.

Checking Sediment Bowl

1. Park machine safely. Allow engine to cool.
2. Check fuel sediment bowl. If water and deposits are detected, drain water.

- a. Place drain pan under sediment bowl.
- b. Turn drain cock to open position.
- c. Drain water until the orange indicator ring re-seats back on the bottom of bowl.
- d. Turn drain cock to closed position.

Cleaning Sediment Bowl and Replacing Fuel Filter

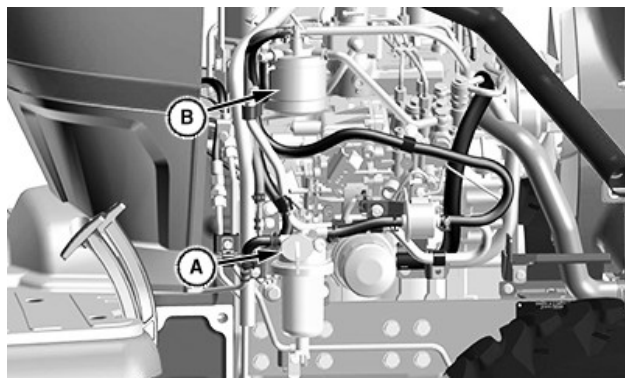

LV29096—UN—21SEP17

A—Fuel Shut-Off Valve
B—Fuel Filter

1. Move the fuel shutoff valve (A) to closed position.
2. Position drain pan under fuel filter sediment bowl.
3. Turn sediment bowl counterclockwise to remove.
4. Clean the filter screen and bowl.
5. Install sediment bowl.
6. Open fuel shutoff valve.

NOTE: Fuel system is self bleeding.

7. Turn key to the ON position for 10—15 seconds before attempting to start, electric pump purges air from sediment bowl.

Replacing Fuel Filter

NOTE: Change filter when fuel level is low.

1. Park machine safely. Allow engine to cool.
2. Close fuel shutoff valve.
3. Position drain pan under fuel filter (B) to catch fuel spillage.
4. Turn filter counterclockwise to remove and discard.
5. Apply fuel to surface of new filter gasket.
6. Install new filter to filter head. Tighten to one complete turn after filter contacts head.
7. Open fuel shutoff valve.

UP00731.00003F8-19-21SEP17

Fuel Injection Pump

IMPORTANT: Avoid damage! Do not clean a warm or hot fuel injection pump with steam or water. Clean with compressed air if pump is not cooled.

NOTE: The fuel injection pump is calibrated by the engine manufacturer and should not require any adjustments.

If engine is hard to start, lacks power, or runs rough, see Troubleshooting Section of this manual.

After performing the check in the troubleshooting section and your engine is still not performing correctly, contact your John Deere dealer.

SK35149,00011BE-19-27JUL17

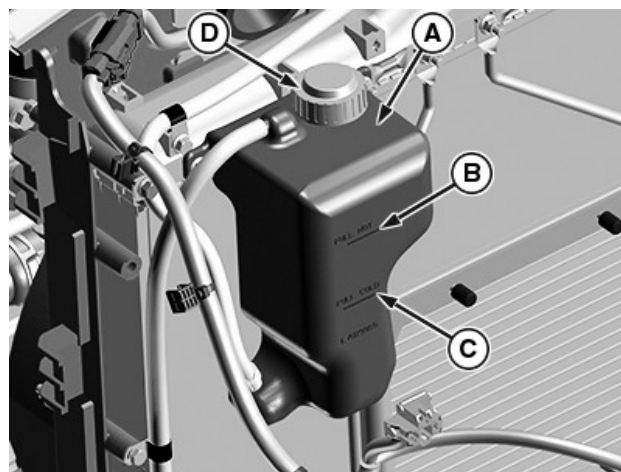

PY38983—UN—17JUL17

A—Recovery Tank
B—Full Hot
C—Full Cold
D—Tank Cap

Fuel Injection Nozzles

IMPORTANT: Avoid damage! Do not service or remove fuel injection nozzles. Service life of injection nozzles may be shortened by overheating, improper operation, poor fuel quality, or excessive idling.

If injection nozzles are not working correctly or are dirty, engine runs poorly. See your John Deere dealer for service.

SK35149,00011BF-19-27JUL17

Drain and Flush Fuel Tank

See your John Deere dealer for draining and flushing the fuel tank.

SK35149,00011C0-19-27JUL17

Check Coolant Level

1. Park machine safely.
2. Raise hood.

3. Check coolant level in the recovery tank (A):
 - If engine is at operating temperature, coolant level is at the FULL HOT line (B).
 - If engine is cold, coolant level is at the FULL COLD line (C) on the recovery tank.
4. To add coolant, remove recovery tank cap (D).

IMPORTANT: Avoid damage! Using incorrect coolant mixture can damage the radiator:

- Do not operate engine with plain water.
- Do not exceed a 50% mixture of coolant and water.
- Aluminum engine blocks and radiators require approved ethylene glycol-based antifreeze.

NOTE: John Deere Cool-Gard™ coolant is recommended when adding new coolant to the cooling system.

Follow the directions on the container for the correct mixture ratio.

5. Add recommended coolant if needed.
6. Install recovery tank cap.
7. Lower hood.

SK35149,00011C1-19-13NOV19

Drain and Flush Cooling System

1. Park machine safely.

Cool-Gard is a trademark of Deere & Company

CAUTION: Explosive release of fluids from pressurized cooling system can cause serious burns.

Shut off engine. Only remove surge tank filler cap when cool enough to touch with bare hands. Slowly loosen cap to first stop to relieve pressure before removing completely.

2. Allow engine to cool.
3. Raise hood.

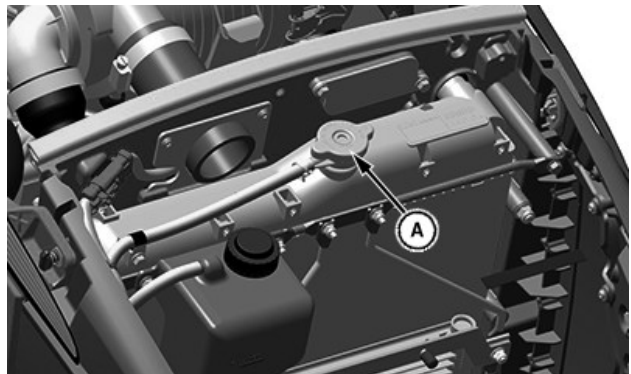

LV29092—UN—16AUG17

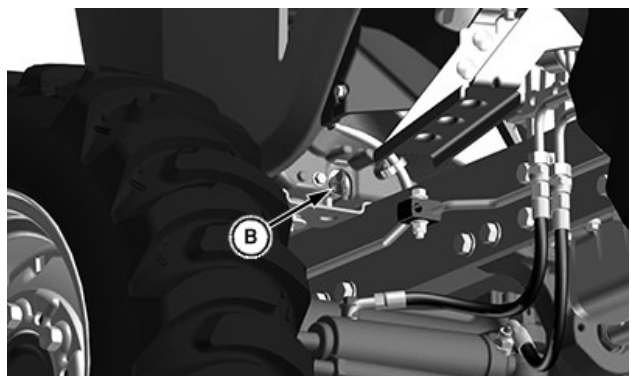

LV29091—UN—16AUG17

A—Radiator Cap
B—Radiator Drain Plug

4. Slowly open radiator cap (A) to the first stop to release all pressure.
5. Close radiator cap tightly.
6. Position a pan under the radiator drain plug (B).
7. Open the drain plug (B) and allow the coolant to drain from the system.
8. When coolant drains from the recovery tank, remove the radiator cap.
9. Close radiator drain plug (B).
10. Fill the cooling system with clean water. Run engine until water passes through the thermostat to stir up possible rust or sediment.
11. Stop engine immediately and drain water from the system before rust and sediment settles.
12. Fill cooling system with clean water and John Deere

Cooling System Cleaner, or John Deere Cooling System Quick Flush or an equivalent. Follow directions on the container.

13. After cleaning the system, drain cleaner and fill the system with clean water to flush the system.
14. Start and run engine until water passes through the thermostat.
15. Stop engine, and drain flushing water from the system.

IMPORTANT: Avoid damage! Using incorrect coolant mixture can damage the radiator:

- Do not operate engine with plain water.
- Do not exceed a 50% mixture of coolant and water.
- Aluminum engine blocks and radiators require approved ethylene glycol-based antifreeze.

NOTE: John Deere Cool-Gard™ coolant is recommended when adding new coolant to the cooling system.

Follow the directions on the container for the correct mixture ratio.

16. Close all drain orifices and fill cooling system to specification.
17. Install radiator cap and run engine until it reaches operating temperature.
18. Stop engine and check coolant level. Add coolant if necessary.
19. Lower hood.

UP00731,00003F6-19-10AUG17

Fill Cooling System

IMPORTANT: Avoid damage! Using incorrect coolant mixture can damage the radiator:

- Do not operate engine with plain water.
- Do not exceed a 50% mixture of coolant and water.
- Aluminum engine blocks and radiators require approved ethylene glycol-based antifreeze.

NOTE: John Deere Cool-Gard™ coolant is recommended when adding new coolant to the cooling system.

Follow the directions on the container for the correct mixture ratio.

COOL-GARD is a trademark of Deere & Company

1. Allow radiator to cool.
2. Fill cooling system.
3. Install and tighten radiator cap.
4. Run engine until it reaches operating temperature.
5. Stop engine.
6. Check coolant level in the recovery tank and add coolant if necessary
7. Lower hood.

SK35149,00011C3-19-27JUL17

Check Radiator Hoses and Clamps

1. Park machine safely.
2. Raise hood.
3. Remove right and left-hand side panels.

NOTE: Visually inspect hoses for cracks and wear. Squeeze hoses to check for deterioration. Hoses should not be hard and brittle, nor soft or swollen.

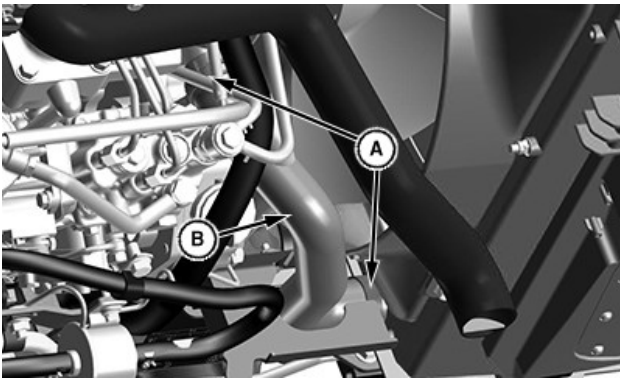

LV29094—UN—03OCT17

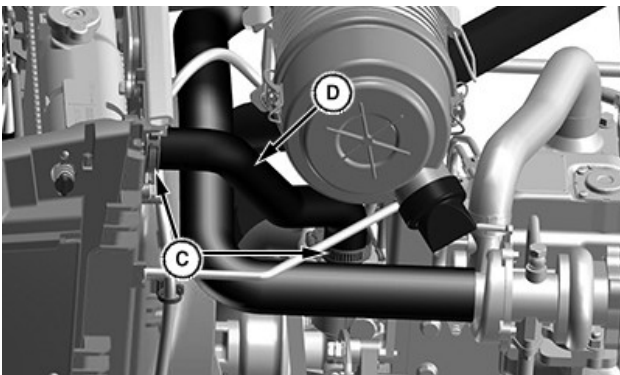

LV29095—UN—03OCT17

- A—Hose Clamp
- B—Upper Radiator Hose
- C—Hose Clamp
- D—Lower Radiator Hose

4. Check upper radiator hose (B) for damage or cracking. Replace if necessary.
5. Check hose clamps (A) as needed.

6. Check lower radiator hose (D) for damage or cracking. Replace if necessary.
7. Check hose clamps (C) as needed.
8. Install right and left-hand side panels.
9. Lower hood.

UP00731,00003F7-19-03OCT17

Clean Radiator, Fuel, and Transmission Cooling Fins

⚠ CAUTION: Avoid injury! Compressed air can cause debris to fly a long distance.

- Clear work area of bystanders.
- Wear eye protection when using compressed air for cleaning purposes.
- Reduce compressed air pressure to 210 kPa (2.1 bar) (30 psi).

IMPORTANT: Avoid damage! Reduced air intake can cause overheating. Keep radiator cooling fins clean.

Do not use pressure washers to clean radiator cooling fins. The force produced by pressure washers can damage the radiator and cooling fins.

1. Park machine safely. Allow engine to cool.
2. Raise hood and slide grille up.

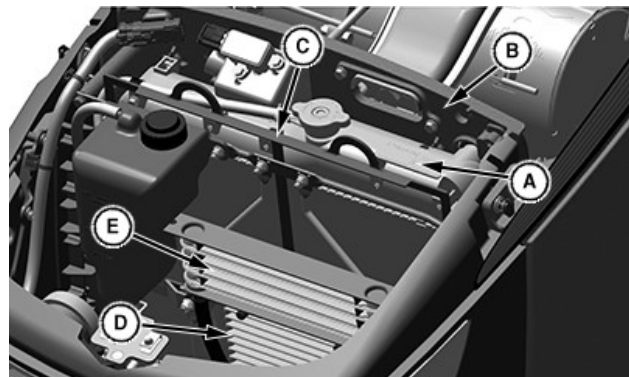

LV29174—UN—08SEP17

- A—Radiator
- B—Fan Shroud
- C—Radiator Screen (If equipped)
- D—Transmission Oil Cooler
- E—Fuel Cooler

3. Slide radiator screen (C) up out of retaining slot.
4. Clean screen with compressed air, brush, or cloth.
5. Using compressed air or water, remove all dirt and debris from fins at front and rear of the following:
 - Radiator (A), including fan shroud (B).
 - Transmission oil cooler (D).

- Fuel cooler (E).

6. Slide grille down and lower hood.

UP00731,000042F-19-10OCT19

Electrical and Lighting Maintenance

Service Electrical

WARNING: Battery posts, terminals and related accessories contain lead and lead components, chemicals known to the State of California to cause cancer and reproductive harm. **Wash hands after handling.**

SK35149,00011A8-19-27JUL17

Prevent Battery Explosions



TS204—UN—15APR13

Keep sparks, lighted matches, and open flame away from the top of battery. Battery gas can explode.

Never check battery charge by placing a metal object across the posts. Use a volt-meter or hydrometer.

Do not charge a frozen battery; it may explode. Warm battery to 16°C (60°F).

DX,SPARKS-19-03MAR93

Remove and Install Battery

Remove:

1. Park machine safely.
2. Raise the hood.
3. Remove side panels.
4. Disconnect headlight harness at fan shroud.
5. Slide grille up.

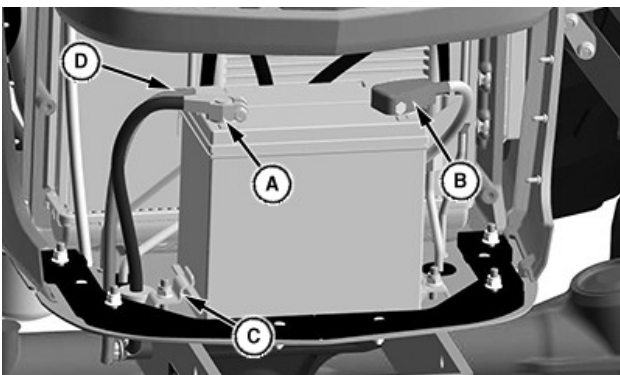

LV29342—UN—08SEP17

- A—Negative (—) Cable
- B—Positive Terminal Cover
- C—Hold Down Bracket
- D—Vent Tube

6. Disconnect black negative (-) cable (B) from the battery terminal first.
7. Slide red positive terminal cover (C) back and disconnect red positive (+) cable from the battery terminal.
8. Remove hold down bracket (C) from both sides of battery tray.
9. Pull battery vent tube (D) from the battery tray.
10. Remove the battery.

Install:

1. Position battery in the machine.
2. Route battery vent tube through the hole in the battery tray.
3. Install hold down brackets securing battery to battery tray.
4. Connect positive (+) cable to battery first, then attach negative (-) cable to the battery.
5. Apply spray lubricant on the battery terminals to help prevent corrosion.
6. Position red positive battery terminal cover on the red positive (+) cable.
7. Slide grille back into position.
8. Connect headlight harness at fan shroud.
9. Install side panels.
10. Lower the hood.

SK35149,00011AA-19-08SEP17

Clean Battery and Terminals

1. Park machine safely.
2. Disconnect and remove battery.
3. Wash battery with solution of four tablespoons of baking soda to one gallon of water. Be careful not to get the soda solution into the cells.
4. Rinse the battery with plain water and dry.
5. Clean terminals and battery cable ends with wire brush until bright.
6. Install battery.
7. Attach cables to battery terminals, beginning with the positive cable.
8. Apply spray lubricant to terminal to prevent corrosion.

SK35149,00011A8-19-27JUL17

Use Booster Battery

CAUTION: Avoid injury! The battery produces a flammable and explosive gas. The battery may explode:

- Do not smoke or have open flame near the battery.
- Wear eye protection and gloves.
- Do not jump-start or charge a frozen battery. Warm battery to 16°C (60°F).
- Do not connect the negative (-) booster cable to the negative (-) terminal of the discharged battery. Connect at a good ground location away from the discharged battery.

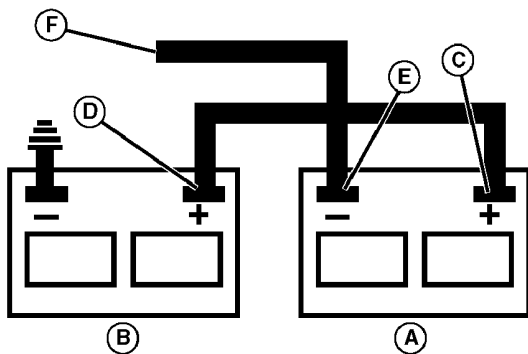

LVAL38352—UN—21AUG12

- A—Booster Battery
- B—Disabled Vehicle Battery
- C—Booster Battery Positive (+) Post
- D—Disabled Vehicle Battery Positive (+) Post
- E—Booster Battery Negative (-) Post
- F—Disabled Vehicle Battery Negative (-) Post

1. Connect positive (+) booster cable to the booster battery (A) positive (+) post (C).
2. Connect the other end of positive (+) booster cable to the disabled vehicle battery (B) positive (+) post (D).
3. Connect negative (-) booster cable to the booster battery negative (-) post (E).

IMPORTANT: Avoid damage! Electric charge from the booster battery can damage machine components. Do not install negative booster cable to the machine frame. Install only to the engine block.

Install negative booster cable away from moving parts in the engine compartment, such as belts and fan blades.

4. Connect the other end (F) of negative (-) booster cable to a metal part of the disabled machine engine block away from battery.
5. Start the engine of the disabled machine and run machine for several minutes.
6. Carefully disconnect the booster cables in the exact

reverse order: negative cable first and then the positive cable.

SK35149,00011AC-19-27JUL17

Replace Headlight Bulb

IMPORTANT: Avoid damage! Do not touch glass headlight bulb with bare skin. Contact with bare skin could cause bulb to fail prematurely. Use gloves or a cloth when inspecting or replacing the bulb.

1. Park machine safely.
2. Raise hood.

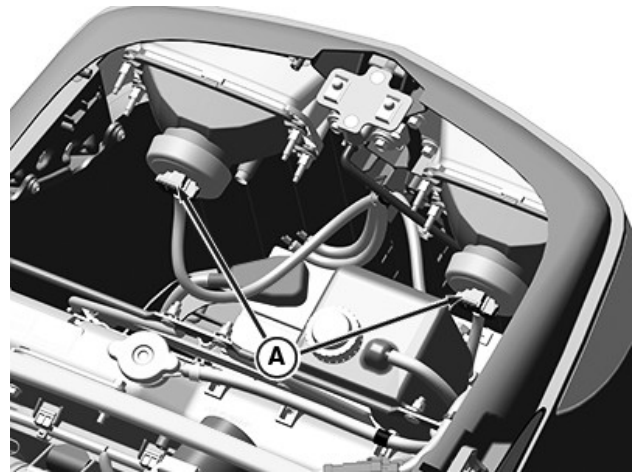

PY38991—UN—17JUL17

A—Headlight Bulb

3. Remove connector from base of headlight bulb (A).
4. Rotate base counterclockwise to remove bulb assembly from housing.
5. Insert new bulb in housing and turn clockwise to secure.
6. Insert connector into base of bulb.
7. Lower hood.
8. Check operation of headlights.

SK35149,00011AD-19-07AUG17

Replacing Tail, Turn and Warning Light Bulbs

NOTE: Taillight can be serviced by removing the rear assembly lens only.

1. Park machine safely.

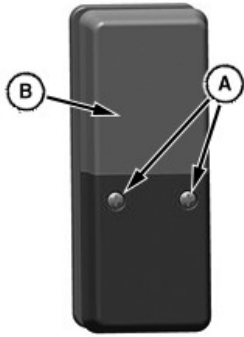

LV29146—UN—17AUG17

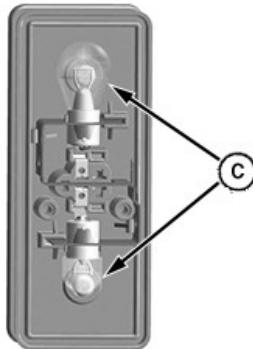

LV29147—UN—17AUG17

A—Screws
B—Lens
C—Bulb

2. Remove two screws (A) and lens (B).
3. Pull bulb (C) straight out to remove. Do not twist bulb.
4. Push new bulb into socket.
5. Check operation of taillights, turn signals and warning lights.
6. Install lens and screws.

UP00731,0000407-19-16AUG17

Replacing Fuses and Relays

IMPORTANT: Avoid damage! The electrical system can be damaged if incorrect replacement fuses are used. Replace the bad fuse with a fuse of the same ampere rating.

Locating Fuses and Relays

All electrical circuits are protected by fuses. Amperage rating is marked on each fuse, plus fuses are color coded to ensure proper replacement.

Fuses	
Fuse Rating	Color
10A	Red
15A	Blue
20A	Yellow
30A	Green



PY38992—UN—17JUL17

A—Load Center Cover

1. Park machine safely.
2. Remove left side panel.
3. Remove load center cover (A).
4. Identify fuse or relay in the fuse block.
5. Pull out the defective relay or fuse.
6. Replace with the new relay or fuse.
7. Install load center cover.
8. Install side panel.

Fuse and Relay Size and Function

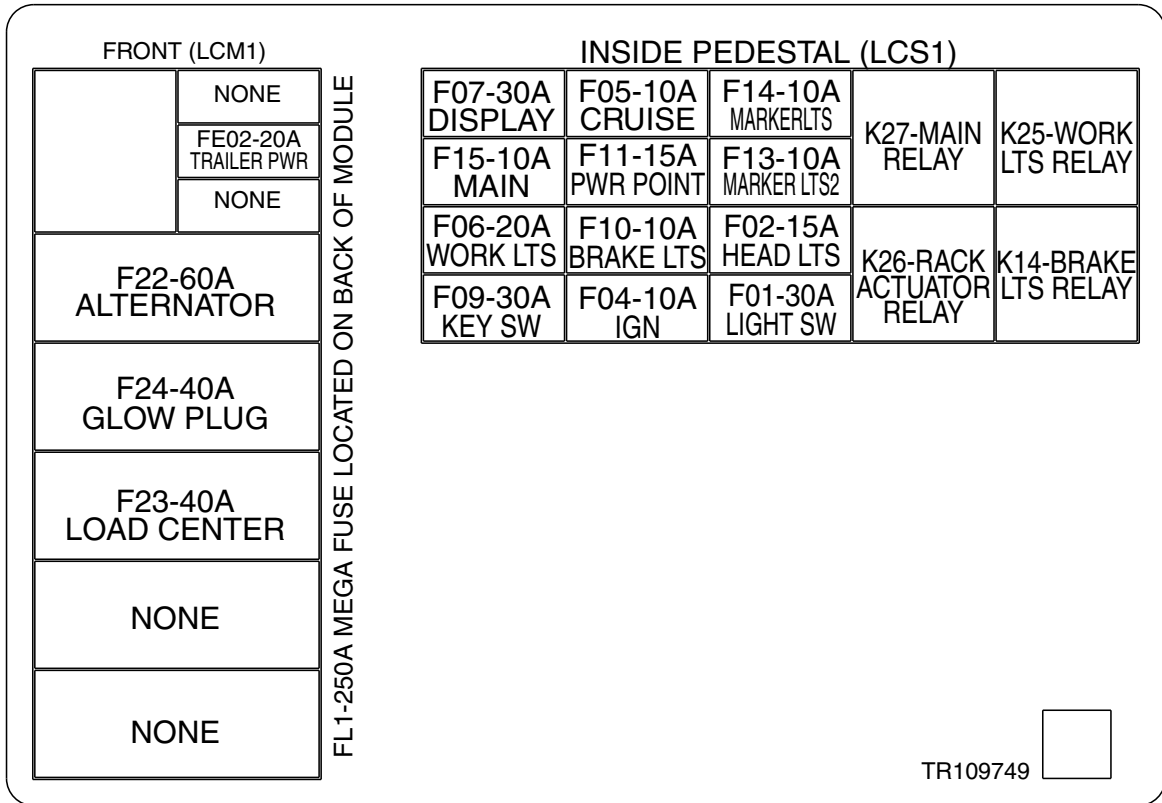

Load Center - 3025E

APY21060—UN—10SEP19

- F01—Light Switch Fuse (30A)
- F02—Head Lights Fuse (15A)
- F04—Ignition Fuse (10A)
- F05—Cruise Control Fuse (10A)
- F06—Work Lights Fuse (20A)
- F07—Display Fuse (30A)
- F09—Key Switch Fuse (30A)
- F10—Brake Lights Fuse (10A)
- F11—Power Point Fuse (15A)
- F13—Marker Lights 2 Fuse (10A)

- F14—Marker Lights Fuse (10A)
- F15—Main Fuse (10A)
- F22—Alternator Fuse (60A)
- F23—Load Center Fuse (40A)
- F24—Glow Plug Fuse (40A)
- FE02—Trailer Power Fuse (20A)
- K14—Brake Lights Relay
- K25—Work Lights Relay
- K26—Rack Actuator Relay
- K27—Main Relay

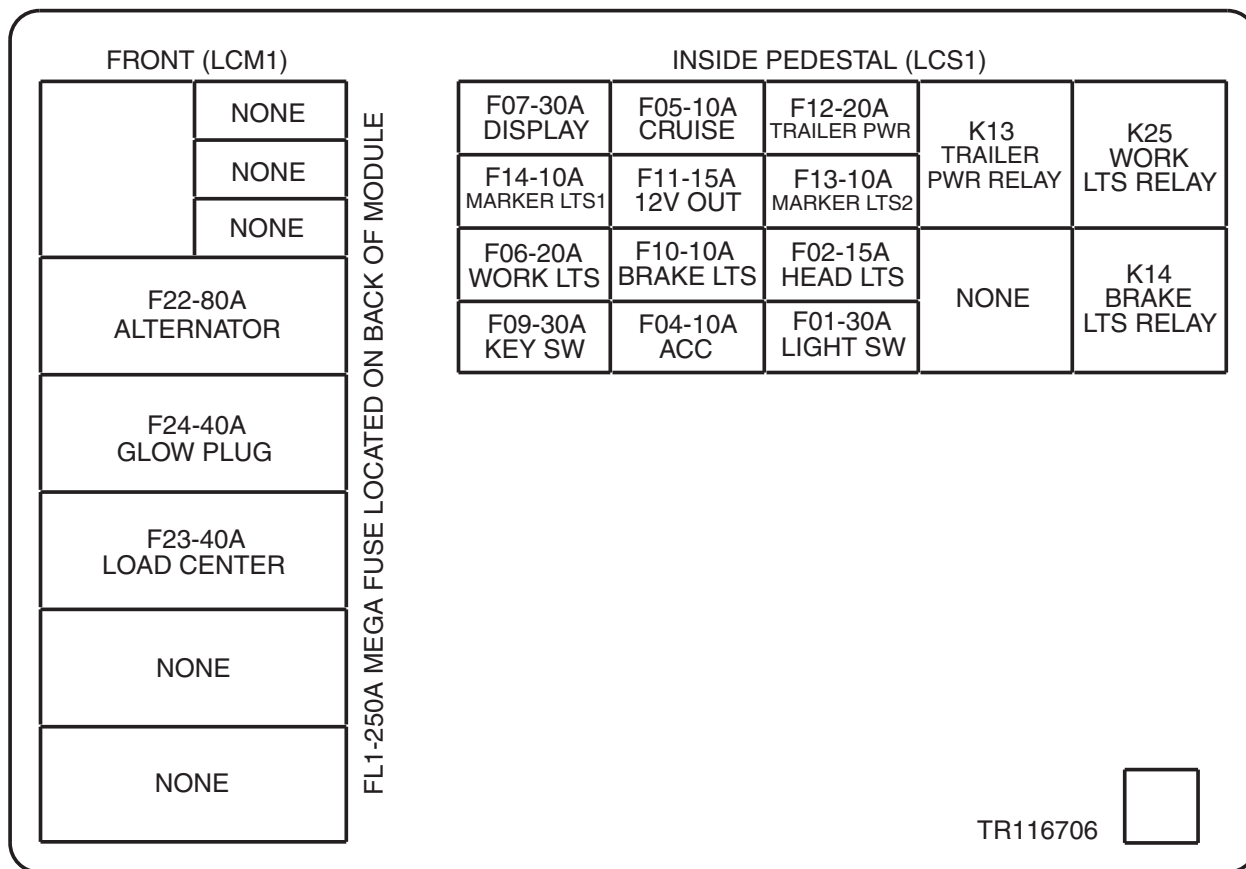

FL1-250A MEGA FUSE LOCATED ON BACK OF MODULE

Load Center - 3038E

LV30714—UN—10MAR20

- F01—Light Switch Fuse (30A)
- F02—Head Lights Fuse (15A)
- F04—Accessory Power Fuse (10A)
- F05—Cruise Control Fuse (10A)
- F06—Work Lights Fuse (20A)
- F07—Display Fuse (30A)
- F09—Key Switch Fuse (30A)
- F10—Brake Lights Fuse (10A)
- F11—12 V Output Fuse (15A)

- F12—Trailer Power Fuse (20A)
- F13—Marker Lights 2 Fuse (10A)
- F14—Marker Lights 1 Fuse (10A)
- F22—Alternator Fuse (80A)
- F23—Load Center Fuse (40A)
- F24—Glow Plug Fuse (40A)
- K13—Trailer Power Relay
- K14—Brake Lights Relay
- K25—Work Lights Relay

PP71895.000146D-19-09JUN20

Drivetrain Maintenance

Drivetrain Maintenance

See specific drivetrain component for maintenance information.

SK35149,00011C9-19-27JUL17

Transmission Maintenance

Check Transmission Oil Level

1. Park machine safely. Allow machine to cool down for at least 1 hour.

IMPORTANT: Avoid damage! Dirt and contamination can enter transmission when checking oil level. Clean area around dipstick before removing.

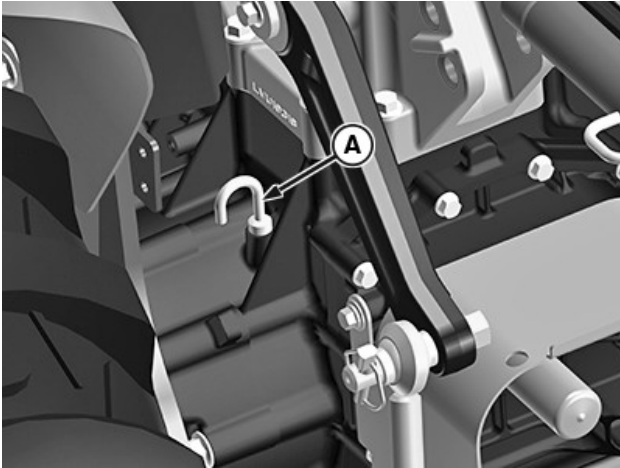

A—Dipstick

PY38994—UN—17JUL17

2. Pull to remove dipstick (A), at the right side of the transmission. Wipe with a clean cloth.
3. Install dipstick.
4. Remove dipstick.

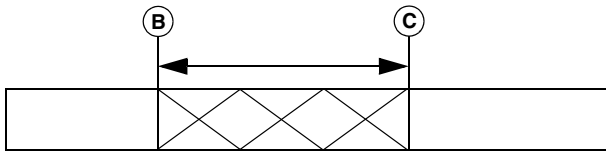

B—Minimum Oil Level Mark
C—Maximum Oil Level Mark

LVAL38336—UN—21AUG12

5. Check oil level on dipstick. Ensure that oil level is between levels (B) and (C) on dipstick.

IMPORTANT: Avoid damage! Help prevent dirt and other contaminants from entering the transmission. Clean area around fill cap before removing.

Do not overfill transmission. Oil expands during operation and could overflow.

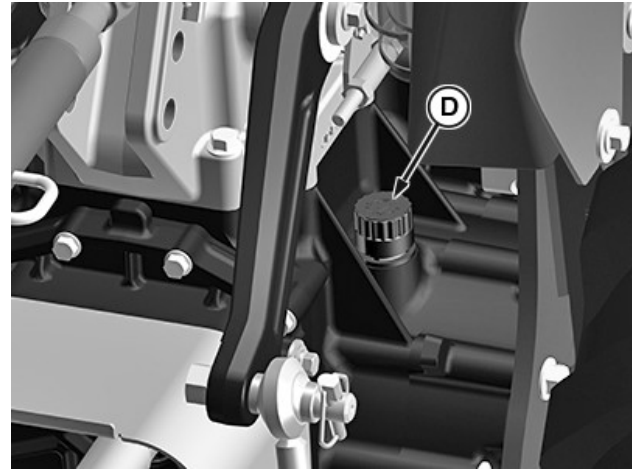

PY38995—UN—17JUL17

D—Oil Filler Cap

6. If oil level is low:
 - Remove filler cap (D).
 - Add recommended oil through fill opening until oil level is correct.
7. If oil is above the top mark on the dipstick, drain to the proper level.
8. Install dipstick.
9. Install and tighten filler cap.

SK35149,00011C6-19-10OCT19

Change Transmission Oil and Filter

CAUTION: Avoid injury! Touching hot surfaces can burn skin. The engine, components, and fluids are hot if the engine has been running. Allow the engine to cool before servicing or working near the engine and components.

IMPORTANT: Avoid damage! If there is evidence of severe oil contamination, it may be necessary to change the oil several times.

Contamination of hydraulic fluid could cause transmission damage or failure.

Severe or unusual conditions require a more frequent service interval.

NOTE: Transmission oil can be changed every 1200 hours or 3 years if the following requirements are met:

- Use John Deere Hy-Gard™ or Lo-Vis Hy-Gard oil.
- Suction and transmission filter are both changed every 400 hours.
- Perform oil-scan of transmission oil every 400 hours or once per year.

Hy-Gard is a trademark of Deere & Company

1. Drive tractor a few minutes to warm the transmission oil.
2. Park machine safely.

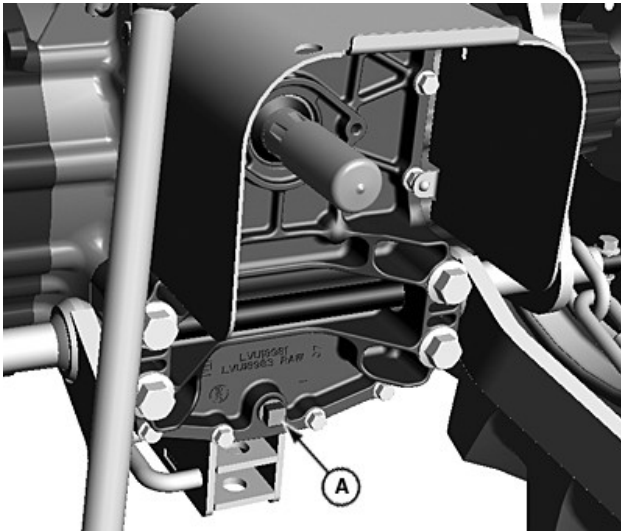

LV17260—UN—26MAR13

A—Transmission Drain Plug

3. Position the drain pan under the transmission drain plug (A). Remove the plug and allow oil to drain completely.

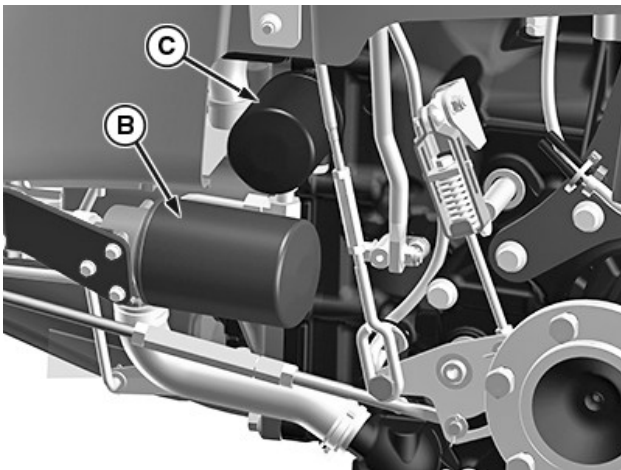

PY38997—UN—17JUL17

B—Hydraulic Suction Filter
C—HST Filter

4. Position the drain pan under the hydraulic suction filter (B) and HST filter. Remove and discard the filter. Allow residual oil to drain completely.
5. Put a film of clean transmission oil on the seal of the new filter.
6. Fill the filter 1/3 - 1/2 full of oil.
7. Install the filter and turn clockwise until the gasket contacts the mounting surface. Tighten 1/2 - 3/4 turn after gasket contact.
8. Install and tighten the drain plug.

IMPORTANT: Avoid damage! Help prevent dirt and other contaminants from entering the transmission. Clean area around the fill cap before removing.

Do not overfill the transmission. Oil expands during operation and could overflow.

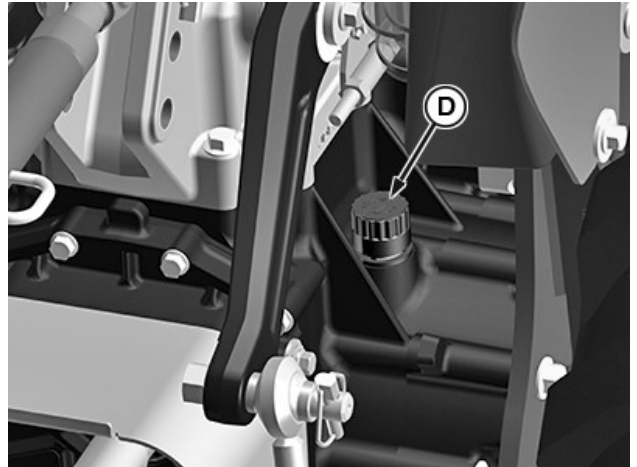

PY38995—UN—17JUL17

D—Fill Cap

9. Remove the fill cap (D).
10. Add transmission oil into the fill opening.
11. Install the fill cap.
12. Start the engine. Check for oil leaks.
13. Stop the engine.
14. Check the transmission oil level. Add oil if necessary.

JC48530.000042A-19-11FEB20

MFWD and Front Axle Maintenance

Check Front Axle Oil Level

NOTE: To ensure accurate dipstick reading, allow oil to settle for one hour before checking. Repeat oil level check after several hours of operation.

1. Park machine safely on level surface. Allow machine to cool down for at least one hour.

IMPORTANT: Dirt and debris cause damage to the transaxle. Clean area around opening before removing dipstick.

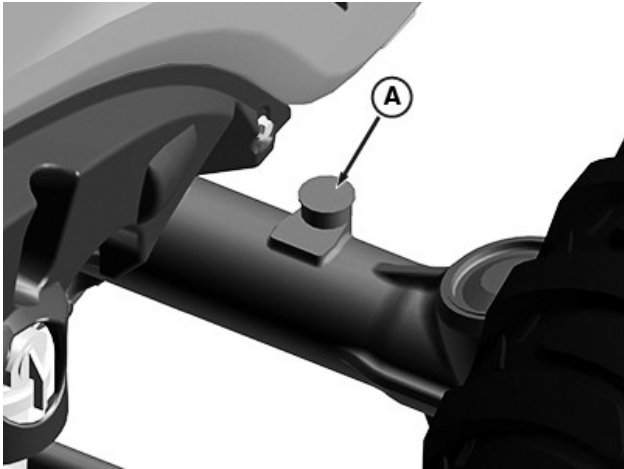

PY46001—UN—17JUL17

A—Dipstick

2. Loosen and remove dipstick (A) located on right side of front axle.
3. Wipe dipstick clean with a rag. Install dipstick but do not tighten. Allow dipstick to rest on top of threads.



LVAL38331—UN—21AUG12

B—High Oil Level
C—Low Oil Level

4. Remove dipstick. Oil level should be between high (B) and low (C) levels on dipstick. If oil level is low:
 - a. Add recommended oil through dipstick fill opening until oil level is correct.
 - b. Install and tighten dipstick.
5. Check front axle oil level again after the first several hours of operation.

SK35149,00011A4-19-27JUL17

Change Front Axle Oil

1. Warm front axle oil by operating machine.
2. Park machine safely.

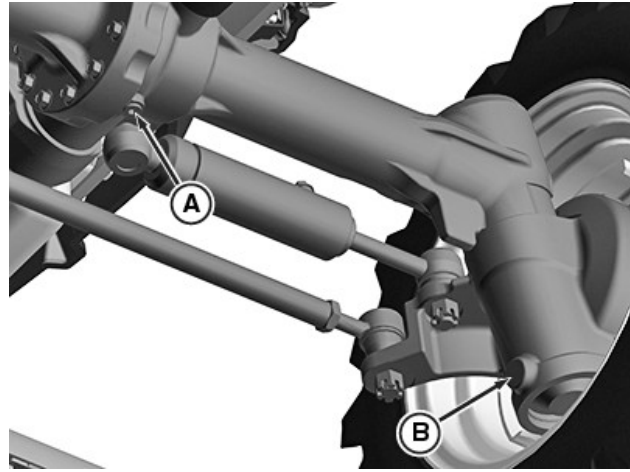

PY46002—UN—17JUL17

A—Differential Drain Plug
B—Front Axle Drain Plug

3. Position drain pan under the differential drain plug (A).
4. Remove the differential drain plug and allow oil to drain.
5. Position drain pan under the front axle drain plug (B).
6. Remove the drain plug and allow oil to drain.
7. Position drain pan under the axle on the other side and repeat the procedure.
8. Install and tighten both drain plugs after all oil has drained.

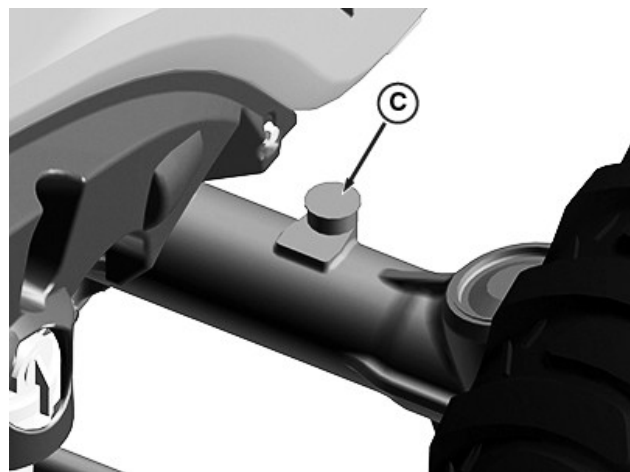

PY46003—UN—17JUL17

C—Dipstick

9. Remove dipstick (C) on the right side of the front axle.
10. Add recommended oil through dipstick fill opening until oil level is correct.

11. Install and tighten the dipstick.

NOTE: To ensure accurate dipstick reading, allow oil to settle for 1 hour before checking. Repeat oil level check after several hours of operation.

12. Check front axle oil level.

SK35149,00011A5-19-21SEP17

Adjusting Front Axle Thrust Bolt Torque

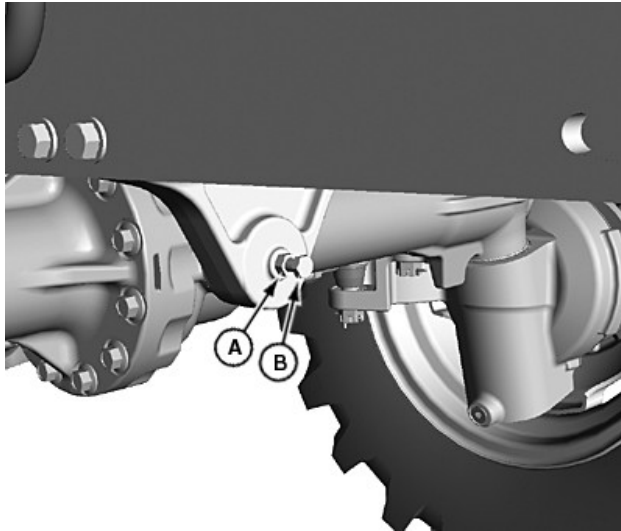

LV17235—UN—26MAR13

A—Nut
B—Thrust Bolt

NOTE: Adjust bolt torque at required service interval to prevent excessive forward or rearward movement of front axle.

1. Park machine safely.

CAUTION: Avoid injury! The machine can fall or slip from an unsafe lifting device or supports.

- Use a safe lifting device rated for the load to be lifted.
- Lower machine onto jack stands or other stable supports and block wheels before servicing.

2. Raise front axle off ground to take machine weight off the front axle.

3. Loosen nut (A).

4. Tighten thrust bolt (B).

Specification

Thrust Bolt—Torque. 14 N·m
(10 lb·ft)

Do not overtighten.

5. Oscillate axle from stop to stop. Check torque.

6. Tighten back nut.

7. Lower front axle back to ground.

SK35149,00011F1-19-10AUG17

Lubricating Axle Trunnion

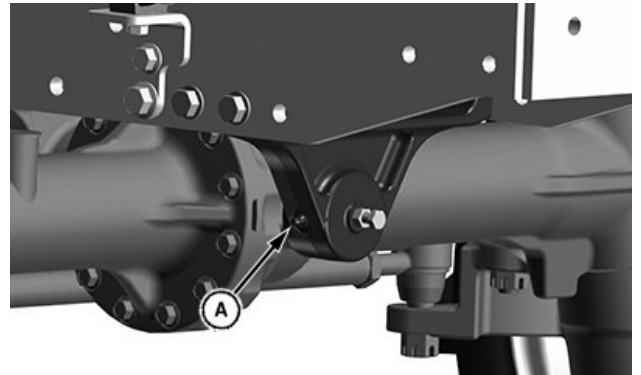

LV25629—UN—13JUN16

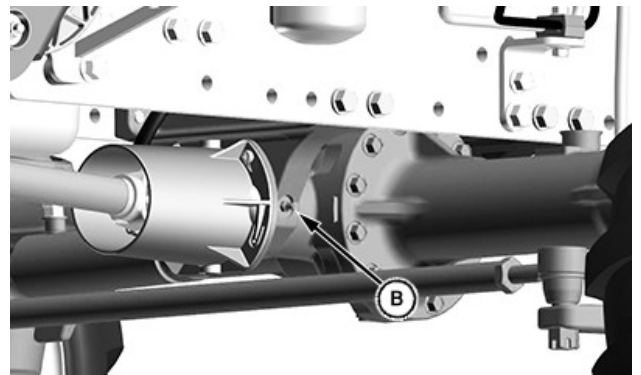

LV25630—UN—13JUN16

A—Front Trunnion Grease Fitting
B—Rear Trunnion Grease Fitting

- Lubricate front trunnion grease fitting (A) and rear trunnion grease fitting (B) with recommended grease or equivalent.

UP00731,000044E-19-19SEP17

Differential and Rear Axle Maintenance

Rear Axle Maintenance

The rear axle is a part of the transmission. See Transmission Maintenance for rear axle information.

SK35149,0001175-19-10AUG17

Power Take Off (PTO) Maintenance

PTO Maintenance

See specific system for maintenance.

SK35149,0001176-19-24JUL17

Steering and Brake Maintenance

Check and Adjust Toe-In

1. Stop machine on a firm, level surface.
2. Disengage MFWD if equipped.
3. Turn steering wheel so front wheels are pointing straight ahead.
4. Park machine safely.

Check Toe-In

NOTE: If front axle is equipped with bar tires, use either an outside or inside bar of each tire for marking the centerline.

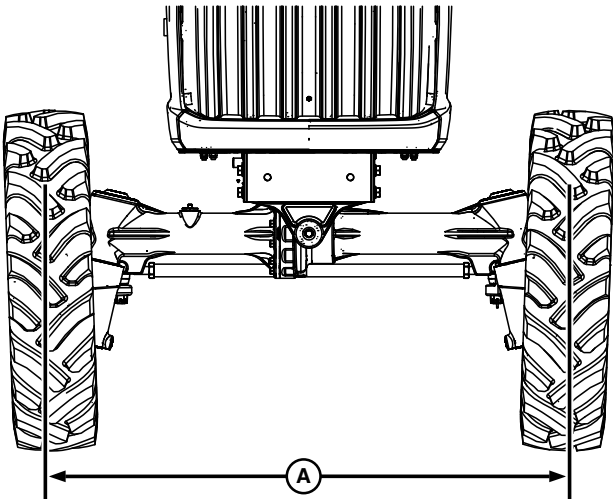

LV17448—UN—12APR13

1. Mark the centerline of each tire at hub height and to the front of the axle using chalk.
2. Measure and record distance (A) between center lines of each tire.
3. Drive machine forward or rearward slightly until chalk mark moves 180° to rear of axle.
4. Park machine safely.
5. Measure and record distance (A) again between the chalk marks.
6. Determine the difference between front and rear measurements. The front measurement should be less than the rear measurement per specification. Adjust toe-in if necessary.

Specification

Toe-in (A)—Distance. 0—3 mm
0—0.125 in

Adjust Toe-In

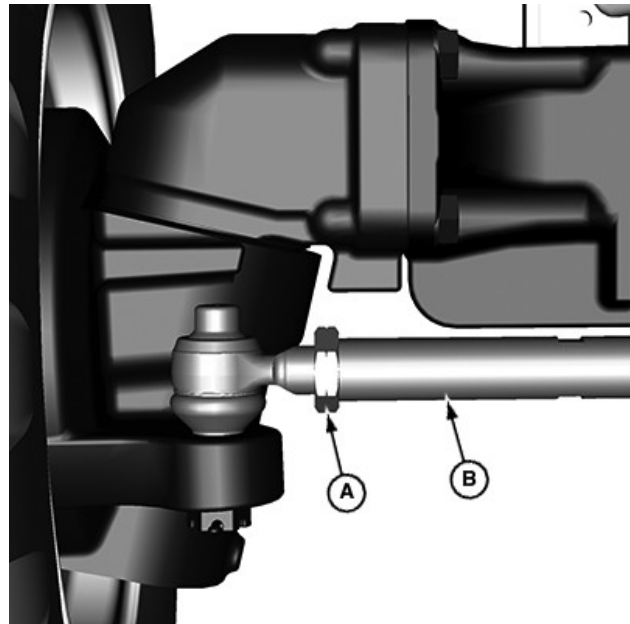

LV17669—UN—02MAY13

- A—Nuts
- B—Tie Rod

1. Loosen nuts (A) on both ball joints.
2. Rotate tie rod (B) clockwise or counterclockwise to adjust the amount of toe-in. Adjust tie rod until toe-in measurement is within specification.

NOTE: Rotating threaded rod in 1/2- turn increments equals 1.5 mm (1/16 in.).

3. Tighten nuts to specification..

Specification

Nut (A)—Torque. 120 N·m
88 lb·ft

4. Check toe-in setting. Repeat procedure if further adjustment is required.

KN52281,10048A0-19-14AUG17

Steering Maintenance

See your John Deere dealer if steering problems exist on the machine.

SK35149,0001177-19-24JUL17

Brake Maintenance

See your John Deere dealer if brake problems exist on the machine.

SK35149,0001178-19-24JUL17

Hydraulics Maintenance

Hydraulic Maintenance

See the Transmission Maintenance section for servicing hydraulic oil and filters.

SK35149,0001179-19-24JUL17

Hitch and Drawbar Maintenance

Lubricate 3-Point Hitch (If Equipped)

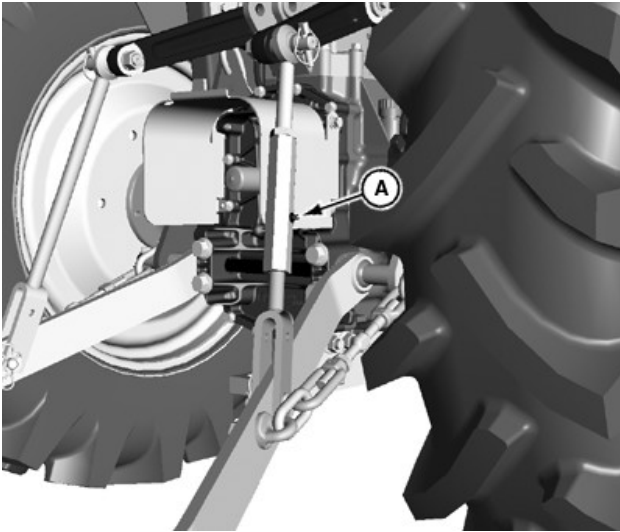

LV17122—UN—21MAR13

A—Lift Link Grease Fitting

1. Lubricate lift link grease fitting (A) with recommended grease or equivalent.

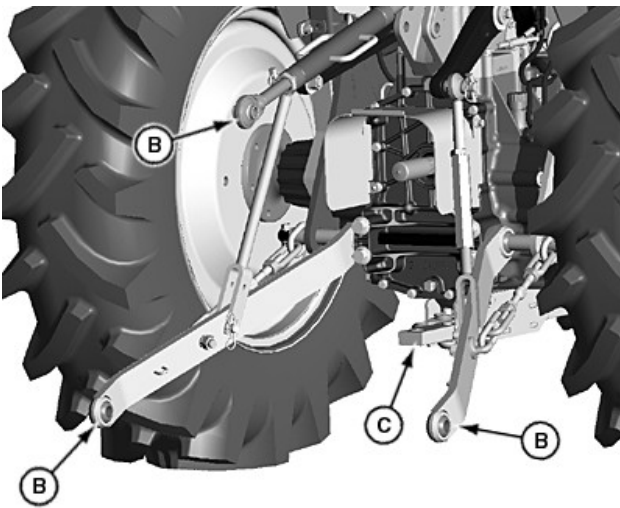

LV17112—UN—21MAR13

B—Ball Joints
C—Drawbar Hitch

2. Lubricate ball joints (B) and drawbar hitch (C) with the SUPER LUBE® lubricant.¹

GS25068,0003D77-19-22JAN18

¹ SUPER LUBE is a registered trademark of Synco Chemical Corp.

Selective Control Valve Maintenance

Check Selective Control Valve

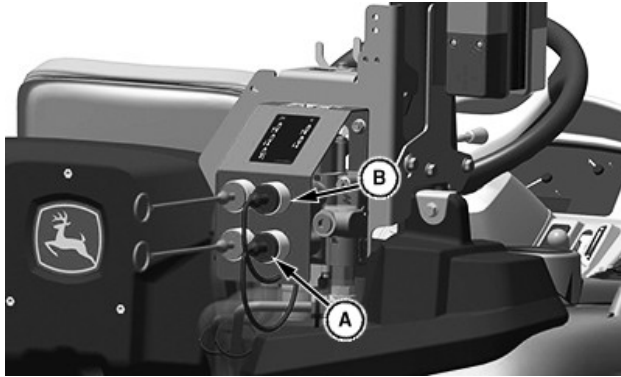

SCV Couplers

LV29159—UN—23AUG17

A—Dust Plug
B—Coupler

1. Check the dust plugs (A) for damage, replace as needed.
2. Clean dirt and debris from the selective control valve couplers (B).
3. Check selective control valve couplers (B) for oil leakage. Contact your John Deere dealer for service.

UP00731,000041A-19-23AUG17

Wheels and Tires Maintenance

Check Wheel Bolts and Hardware

CAUTION: Avoid injury! Check rim, hub, and axle hardware periodically to prevent possible machine roll-over.

When machine is new, check wheel bolt torque after first ten hours of use.

Anytime wheel hardware is loosened, tighten all bolts after one hour of operation and every four hours thereafter until proper torque values are maintained.

Tightness of wheel hardware must be maintained according to service interval recommendations.

Check wheel bolt tightness and torque to specification.

SK35149,000117B-19-24JUL17

Remove and Install Wheels

CAUTION: Avoid injury! Remove wheels safely.

- Use a safe lifting device and support machine securely on jack stands.
- Block front and rear of wheel not raised to prevent machine movement.
- Wheel can be heavy or difficult to handle when removing.

1. Loosen lug bolts slightly before raising machine.
2. Raise machine and lower onto jackstand.
3. Remove lug bolts and wheel.
4. Install wheels onto axle, insert lug bolts, and lightly tighten bolts.
5. Raise machine, remove jackstand and lower machine to floor.
6. Tighten wheel bolts alternately to specification.

Specification

Wheel Bolt —Torque. 140 N·m
(103 lb·ft)

SK35149,000117C-19-10AUG17

Check Tire Pressure

CAUTION: Avoid injury! Explosive separation of tire and rim parts is possible when they are serviced incorrectly:

- Do not attempt to mount a tire without the proper equipment and experience to perform the job.
- Do not inflate the tires above the recommended pressure.
- Do not weld or heat a wheel and tire

assembly. Heat can cause an increase in air pressure resulting in an explosion. Welding can structurally weaken or deform the wheel.

- Do not stand in front or over the tire assembly when inflating. Use a clip-on chuck and extension hose long enough to allow you to stand to one side.

1. Check tires for damage.
2. See tire pressures in Specifications.
3. Check tire pressure with an accurate gauge.
4. Add or remove air if necessary.

SK35149,000117D-19-24JUL17

Tire Inflation Pressure Chart

	Tire Size	Tread	Load Index	Speed Category	Factory Inflation (kPa)	Factory Inflation (psi)
Rear	15.00-19.5 6PR R4	R4	130	A6	210	30
Front (R4 Industrial)	25x8.5-14 6PR R4	R4	97	A6	340	49
Rear	41x14.-00-20 4PR R3	R3	120	B	170	25
Front FWD (R3 Turf)	27x8.5-0-15 6PR R3	R3	100	A6	310	45
Rear	11.2-24 6PR R1	R1	110	A6	180	26
Front (R1 AG)	7.00-14 6PR R1	R1	97	A6	250	36
Rear	43x16-20 4PR R4	Larger R4	120	A6	140	20
Front (R4 Industrial)	27x8.5-0-15 4PR R4	Larger R4	100	A6	310	45
Rear (R1)	320 / 70 R24 R1	R1	116	A8	62	9
Front (R1)	200 / 70 R16 R1	R1	94	A8	242	35

In order to achieve maximum drawbar pull, maintain

proper steering ability, and reduce tire wear and fuel consumption, comply with the correct tire combinations.

UP00731,000047B-19-30JAN18

Select Front Tire Rolling Direction

⚠ CAUTION: Avoid injury! Remove wheels safely.

- Use a safe lifting device and support machine securely on jack stands.
- Block front and rear of wheel not raised to prevent machine movement.
- Wheel can be heavy or difficult to handle when removing.

Machines equipped with directional type tires (such as bar tires) have directional arrows located on the tire sidewall. Under most conditions, tires should be installed with the directional arrow pointing in the direction of travel.

If machine is mainly used for loader operations, lug direction may be reversed to increase tire life and improve traction while backing out of dirt piles.

Move wheel from one side of machine to the other to change tire rolling direction.

Wheel must be installed so that valve stem is facing outwards.

SK35149,000117F-19-24JUL17

Changing Wheel Spacing and Tread Width

In special cases, front tires can be set to wide position; however, wide position cannot be used with a loader. Using wide position during loader operation reduces front axle life.

Mounting Guidelines

- To keep tire rotation in right direction, move each rim to opposite side of machine, rather than turning around rim.
- Dished wheels can be reversed.
- Tighten all bolts to specifications.

Rear Tires

Rear Tire Size	Tire Position	
	Track Width (min)	Track Width (max)
15.00-19.5 6PR R4	1086 mm (42.8 in)	1206 mm (47.5 in)
41x14.00-20 4PR R3	1104 mm (43.5 in)	1224 mm (48.2 in)
11.2-24 6PR R1	1149 mm (45.2 in)	1269 mm (50.0 in)
43x16-20 4PR R4	1154 mm (45.4 in)	1274 mm (50.2 in)
320 / 70 R24 R1	1149 mm (45.2 in)	1279 mm (50.4 in)

Front Tires

Front Tire Size	Tire Position	
	Track Width (min)	Track Width (max)
25x8.5-14 6PR R4	1064 mm (41.9 in)	1231 mm (48.5 in)
27x8.50-15 6PR R3	1060 mm (41.7 in)	1232 mm (48.5 in)
7.00-14 6PR R1	1036 mm (40.8 in)	1256 mm (49.4 in)
27x8.50-15 4PR R4	1035 mm (40.7 in)	1259 mm (49.6 in)
200 / 70 R16 R1	1082 mm (42.6 in)	1211 mm (47.7 in)

CM74493,00000E7-19-30JAN18

Lift Points for Jacking up the Tractor

The illustrations show the recommended lifting points for jacking up the tractor. Use a stable lifting jack with sufficient lifting force.

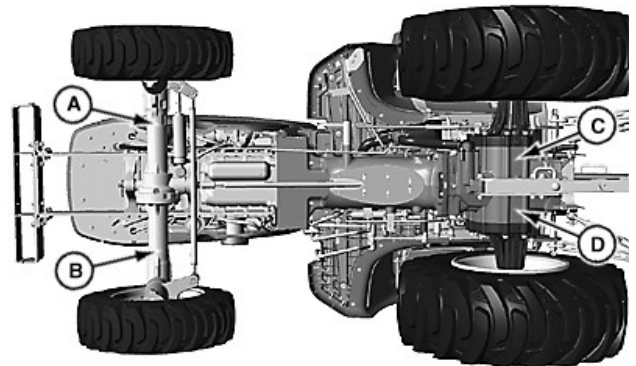

LV18870—UN—23AUG13

- A**—Raise left end of axle at this point to remove left front wheel.
- B**—Raise right end of axle at this point to remove right front wheel.
- C**—Raise left rear of tractor at this point to remove left rear wheel.
- D**—Raise right rear of tractor at this point to remove right rear wheel

SK35149,0001180-19-30JAN18

Ballast Maintenance

Match Ballast to Work Load

Use no more ballast than necessary and remove ballast when it is no longer required.

Rather than weighing tractor down to pull heavy loads, try to reduce load. Pulling a lighter load is more economical and more efficient.

Not Enough Ballast	Too Much Ballast
Excessive wheel slip	Increased load
Power loss due to churning of soil	Power loss due to carrying extra weight
Tire wear	Tire strain
Fuel waste	Soil compaction
Lower productivity	Fuel waste
	Lower productivity

SK35149,0001181-19-24,JUL17

Additional Equipment Maintenance

Additional Equipment Maintenance

To service additional equipment, refer to the additional equipment operator's manual.

SK35149,0001182-19-24JUL17

Operator Station Maintenance

Raise and Lower Hood

1. Park machine safely.

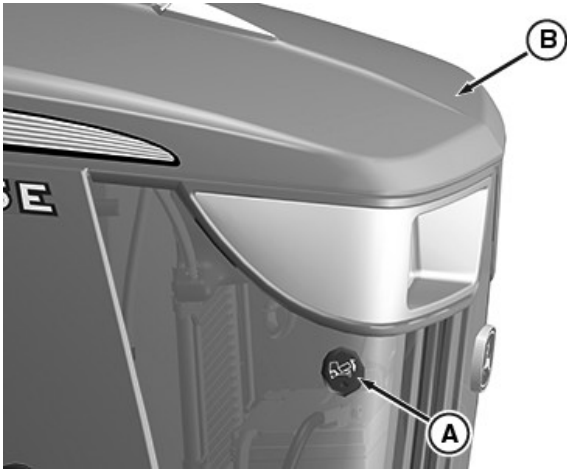

PY46005—UN—17JUL17

A—Hood Release
B—Hood

2. Insert a screw driver, or something similar, into the hood release (A) to release latch.
3. Raise hood (B).
4. To lower, gently push down on both sides of front of hood to lock latch.

SK35149,000119F-19-26JUL17

Remove and Install Side Panels

1. To remove the side panels:
 - a. Park machine safely.
 - b. Raise hood.

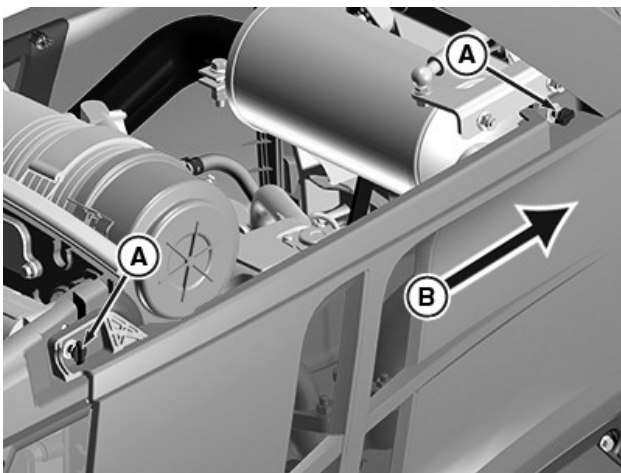

PY46006—UN—23AUG17

Left side shown.

A—Locking Pin
B—Rear Of Machine

- c. Turn the locking pin (A) a 1/4 turn to release the side panel.
- d. Slide the side panel toward the rear (B) of the machine until all the tabs clear their mounting slots in the machine. Remove the side panel.

IMPORTANT: Damage can result to locking pin when closing the hood. Make sure that locking pin is back into place before closing the hood.

- e. Push locking pin (A) back into place.
2. To install side panels:
 - a. Align the panel mounting tabs with the mating slots in the machine.
 - b. Pull locking pin and slide the panel forward to install. Turn locking pin a 1/4 turn to lock into place.
 - c. Lower the hood.

SK35149,00011A0-19-26JUL17

Hood Cowl Removal and Installation

Removal

1. Park machine safely.
2. Open hood.

IMPORTANT: Cowl seal can be damaged if hood is not opened prior to removal and installation of cowl

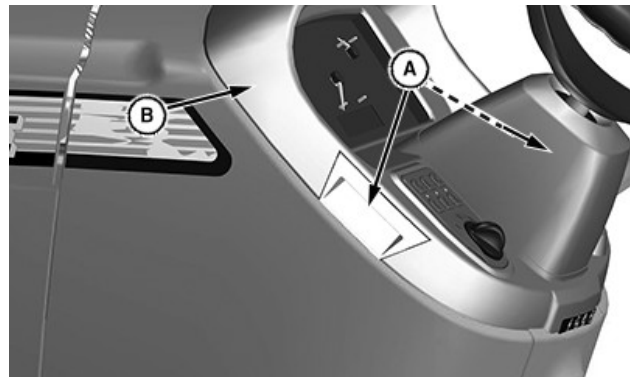

LV29589—UN—19JAN18

A—Hood Cowl Latch
B—Hood Cowl

3. Pull hood cowl latch (A) out on both sides.
4. Slide hood cowl (B) up.

Installation

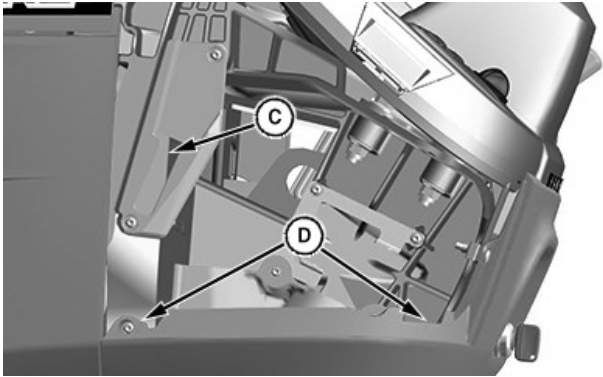

LV29590—UN—19JAN18

C—Alignment Slots
D—Alignment Slots

1. Align hood cowl tabs with alignment slots (C and D).
2. Gently slide cowl into position.
3. Pull hood cowl latch out and release.
4. Close hood.

CM74493.00000E8-19-30JAN18

Inspect ROPS for Loose Hardware

⚠ CAUTION: Make certain all parts are reinstalled correctly if the roll-over protective structure (ROPS) is loosened or removed for any reason. Tighten mounting bolts to proper torque. The protection offered by ROPS is impaired if ROPS is subjected to structural damage, is involved in an overturn incident, or is in any way altered by welding, bending, drilling, or cutting. A damaged ROPS must be replaced, not reused.

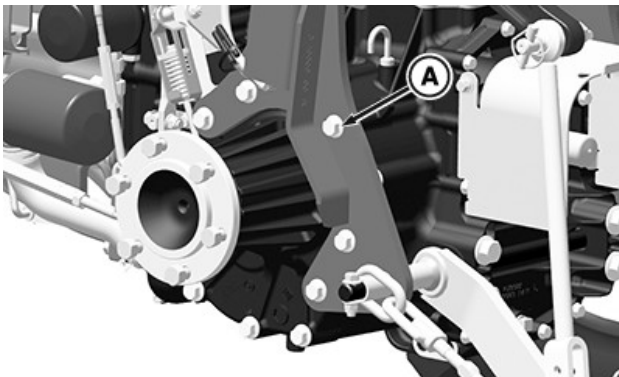

PY28629—UN—26JUL17

A—Bolt (5 each side)

Tighten the ROPS attaching hardware on each side of the ROPS to specification.

Specification

Mounting Bolts (A)—Torque. 95 N·m
(70 lb·ft)

CM74493.0000100-19-31JAN18

Troubleshooting

Information Display Fault Messages

Symptom	Problem	Solution
“PTO Switch Fault” Message	Fault with the PTO circuit	See a John Deere dealer
“PTO Coil Fault” Message	Fault with the PTO Solenoid	See a John Deere dealer
“Pull Coil Fault” Message	Fault with fuel shut off circuit	See a John Deere dealer
“Hold Coil Fault” Message	Fault with fuel shut off circuit	See a John Deere dealer
“Start Coil Fault” Message	Fault with starting circuit	See a John Deere dealer
“RIO Fault” Message	Fault with RIO circuit	See a John Deere dealer
“Audible Alarm Fault” Message	Fault with information display audible alarm	See a John Deere dealer
“Engine Overheat” Message	Coolant level is below specification	Add coolant to specification
	Leak in coolant system	Check for leaks and repair or see your John Deere dealer
	Improperly adjusted or broken fan belt	Tighten or replace fan belt
	Dirt or debris accumulation on hood screen or radiator	Clean debris and dirt from front screen and radiator fins
“Low Fuel” Message	Fuel level low	Fill fuel tank
	Fault with fuel sensing circuit	See a John Deere dealer
“Hydraulic Oil Overtemp” Message	Water in hydraulic oil	Replace hydraulic oil with correct oil type or see a John Deere dealer
	Plugged hydraulic oil filter	Replace oil filter
	Improper type of hydraulic oil	Verify correct hydraulic oil. Drain system and fill with correct oil type
	Oil leaks	Check for leaks and repair or see your John Deere dealer
“Air Filter Restriction” Message	Plugged air filter	Replace air filter elements
	Plugged inlet air filter suction pipe	Clean debris from suction inlet tube

UP00731,0000327-19-12SEP16

Engine

Symptom	Problem	Solution
Engine Will Not Start Or Is Hard To Start	Transmission gearshift lever is not in neutral position	Place range shift lever to Neutral

Troubleshooting

Symptom	Problem	Solution
	Engine throttle lever not pushed forward	Move throttle to half throttle
	Fuel shutoff valve CLOSED (OFF)	Open fuel shutoff valve at the water separator
	Stale fuel/improper fuel/fuel level	Drain stale or improper fuel and fill to capacity
	Wrong engine oil viscosity	Change engine oil and fill with correct viscosity oil for conditions
	Cold start system not being used, or malfunctioning	Verify that cold start system is utilized during required temperatures or see your John Deere dealer
	Plugged fuel filter	Replace fuel filter
	Plugged air intake filter	Clean or replace air filter elements
	Dirty or faulty fuel injectors	See your John Deere dealer
	Blown fuse	Check and replace and faulty fuses
Engine Runs Rough Or Stalls	Fuel shutoff valve partially closed	Open fuel shutoff valve at the water separator
	Plugged fuel filter	Replace fuel filter
	Plugged air intake system	Clean or replace air filter elements
	Stale or improper fuel/fuel level	Drain stale or improper fuel and fill to capacity
	Dirty or faulty fuel injectors	See your John Deere dealer
	Low coolant temperature	See your John Deere dealer
	Fuel pump not functioning properly	See your John Deere dealer
Engine Overheats	Dirt or debris accumulation on hood screen or radiator fins	Clean debris and dirt from the front screen and radiator fins
	Coolant level is below specification	Add coolant as specified
	Leak in the coolant system	Check for leaks and repair or see your John Deere dealer
	Improperly adjusted or broken fan belt	Tighten or replace fan belt
	Cooling system needs flushing	See your John Deere dealer
	Defective radiator cap	Replace radiator cap

Troubleshooting

Symptom	Problem	Solution
	Defective thermostat	See your John Deere dealer
	Defective water temperature indicator or sensor.	See your John Deere dealer
	Loose or defective alternator belt	Tighten or replace belt
	Engine speed too low for load. Do not operate at low idle	Raise engine speed to match load requirements
	Operating at too fast ground speed for conditions	Reduce speed to match operating conditions
Engine Knocks	Fuel shutoff valve partially closed	Open fuel shutoff valve at the water separator
	Plugged fuel filter	Replace fuel filter
	Plugged air intake system	Clean or replace air filter elements
	Stale or improper fuel/fuel level	Drain stale or improper fuel and fill to capacity
	Dirty or faulty fuel injectors	See your John Deere dealer
	Low coolant temperature See your John Deere Dealer	See your John Deere dealer
	Fuel pump not functioning properly	See your John Deere dealer
Low Oil Pressure	Engine oil level low	Add oil to specification
	Plugged engine oil filter	Replace oil filter
	Improper type of engine oil	Verify correct engine oil. Drain system and fill with the correct oil type
	Oil leaks	Check for leaks and repair or see your John Deere dealer
Engine Uses Too Much Oil	Oil leaks	Check for leaks and repair or see your John Deere dealer
	Improper type of engine oil	Verify correct engine oil. Drain system and fill with the correct oil type
Engine Emits White Smoke	Stale or improper fuel/fuel level	Drain stale or improper fuel and fill to capacity
	Internal coolant leak	See your John Deere dealer
Engine Emits Black or Gray Exhaust Smoke	Stale or improper fuel/fuel level	Drain stale or improper fuel and fill to capacity

Troubleshooting

Symptom	Problem	Solution
High Fuel Consumption	Dirty or faulty fuel injectors	See your John Deere dealer
	Fuel pump not functioning properly	See your John Deere dealer
	Stale or improper fuel/fuel level	Drain stale or improper fuel and fill to capacity
	Dirty or faulty fuel injectors	See your John Deere dealer
	Fuel pump not functioning properly	See your John Deere dealer
	Failed fuel solenoid	See your John Deere dealer
	Operating at too fast ground speed for conditions	Reduce speed to match operating conditions
	Improper valve clearance	See your John Deere dealer
Plugged air intake system	Clean or replace air filter elements	

SK35149,0001183-19-24JUL17

Electrical System

Symptom	Problem	Solution
Battery Will Not Charge	Poor electrical connection at alternator	Check for proper electrical connections at alternator
	Loose or corroded connections	Clean connections at alternator and battery terminals
	Check for a blown fuse	Check starting circuit fuses and replace if necessary
	Loose or defective alternator belt	Tighten or replace belt
	Defective battery	Replace battery or see your John Deere dealer
	Defective alternator	See your John Deere dealer
Battery Discharge Indicator Stays On With Engine Running	Poor electrical connection at alternator	Check for proper electrical connections at alternator
	Loose or corroded connections	Clean connections at alternator and battery terminals
	Loose or defective alternator belt	Tighten or replace belt
	Defective battery	Replace battery or see your John Deere dealer
	Defective alternator	See your John Deere dealer

Troubleshooting

Symptom	Problem	Solution
Starter Will Not Work	Poor electrical connection at battery or starter motor	Check for proper electrical connections
	Loose or corroded connections	Clean connections at alternator and battery terminals
	Low battery charge	Charge battery to proper specification
	Defective battery	Replace battery or see your John Deere dealer
	Defective starter motor	See your John Deere dealer
	Check for a blown fuse	Check starting circuit fuses and replace if necessary
	Neutral start switch faulty or not adjusted properly	See your John Deere dealer
	Key switch or starter faulty	See your John Deere dealer
Range transmission lever not in neutral position	Place range transmission lever in neutral	
Starter Turns Slowly	Loose or corroded connections	Clean connections at alternator and battery terminals
	Low battery charge	Charge battery to proper specification
	Defective battery	Replace battery or see your John Deere dealer
	Defective starter motor	See your John Deere dealer
Light Circuit Not Working	Defective bulb	Check and replace faulty bulbs
	Check for a blown fuse	Check light circuit fuses and replace if necessary
	Faulty switch	See your John Deere dealer

SK35149,0001184-19-24JUL17

Machine

Symptom	Problem	Solution
Operation Sluggish, Slow	Water in hydraulic oil	Replace hydraulic oil with correct oil type or see your John Deere dealer
	Plugged hydraulic oil filter	Replace oil filter
	Improper type of hydraulic oil	Verify correct hydraulic oil. Drain system and fill with correct oil type

Troubleshooting

Symptom	Problem	Solution
	Oil leaks	Check for leaks and repair or see your John Deere dealer
Poor Hydraulic Performance	Water in hydraulic oil	Replace hydraulic oil with correct oil type or see your John Deere dealer
	Plugged hydraulic oil filter	Replace oil filter
	Improper type of hydraulic oil	Verify correct hydraulic oil. Drain system and fill with correct oil type
	Oil leaks	Check for leaks and repair or see your John Deere dealer
Machine Will Not Move With Engine Running	Park brake engaged	Release park brake
	Transmission oil level low	Fill hydraulic oil with correct oil type as specified, or see your John Deere dealer
	Transmission oil cold	Allow engine to warm before operating
	Transmission range shift lever in neutral position	Place range transmission lever in high or low range
3-point Hitch Fails To Lift	Transmission oil level low	Fill hydraulic oil with correct oil type to specification or see your John Deere dealer
	Transmission oil cold	Allow engine to warm before operating
	Rate-of-drop valve closed	Open rate-of-drop valve to desired setting
	Excessive load on hitch	Reduce load on hitch
	Plugged hydraulic oil filter	Replace oil filter
	Worn hydraulic pump	See your John Deere dealer
3-point Hitch Lifts Slowly	Transmission oil level low	Fill hydraulic oil with correct oil type as specified, or see your John Deere dealer
	Transmission oil cold	Allow engine to warm before operating
	Excessive load on hitch	Reduce load on hitch
	Plugged hydraulic oil filter	Replace oil filter
	Worn hydraulic pump	See your John Deere dealer

Troubleshooting

Symptom	Problem	Solution
3-point Hitch Drops Slowly Or Does Not Drop	Rate-of-drop valve set too slow	Adjust rate-of-drop valve to desired setting
3-point Hitch Drops Too Fast	Rate-of-drop valve set too fast	Adjust rate-of-drop valve to desired setting
	Excessive load on hitch	Reduce load on hitch
Noise Is Coming From PTO During Operation	Too low engine speed	Increase to rated engine speed

SK35149,0001185-19-24JUL17

Brakes

Symptom	Problem	Solution
Rear Brakes Not Working	Brakes out of adjustment	Adjust brakes to specification
	Worn or damaged brake linkage or brake disks	See your John Deere dealer

SK35149,0001186-19-24JUL17

Steering

Symptom	Problem	Solution
Steering Not Working	Improper tire inflation	Inflate tires to proper specification
	Hydraulic oil level low	Fill hydraulic oil with correct oil type as specified, or see your John Deere dealer
	Hydraulic oil cold	Allow engine to warm before operating
	Plugged hydraulic oil filter	Replace hydraulic oil filter
	Excessive play in steering	See your John Deere Dealer
	Worn hydraulic pump or steering gear	See your John Deere dealer

SK35149,0001187-19-24JUL17

On-Board Diagnostics

Service Alert and Information Display

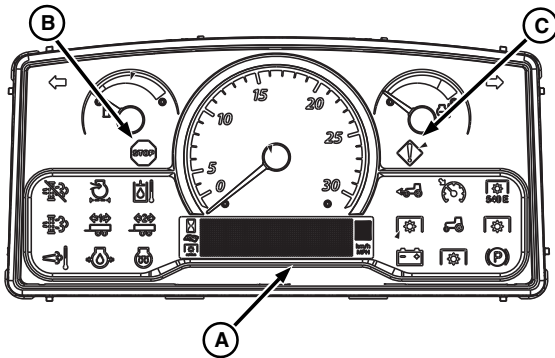

- A—Information Display
- B—Stop Indicator
- C—Service Alert Indicator

LV30635—UN—25SEP19

On-board diagnostic information is displayed using the indicator lights and the information display (A). If the control unit software detects a malfunction or a status “out of the permissible range”, an error message or diagnostic trouble code is displayed. These numbers identify the machine system and problem type.

STOP Indicator (B): The light illuminates and indicates the tractor requires immediate attention or the tractor will be damaged. Correct problem before restarting the engine. See your John Deere dealer if the issue can not be resolved.

Service Alert Indicator (C): The light flashes and indicates a performance problem or malfunction that has to be resolved as soon as possible. Continued operations during a service alert can result in the STOP indicator lighting up. If appropriate corrective action is not taken soon (maintenance, repair, change of operating mode), a significant reduction in performance and/or machine damage will occur.

Whenever a STOP indicator is displayed, switch the transmission to the park position and shut down the engine.

JC48530,00000A8-19-25SEP19

On Board Diagnostic Display

Information Display acts as a visual, user interface device for machine functions and operation. The information display provides normal operational information, such as display settings, performance monitoring and more for selected machine features or functions.

Certain conditions associate displayed text along with instrument cluster icons.



LV25997—UN—15AUG16

Information Display

For more information on instrument cluster icon descriptions see Controls and Instruments section.

For more information on display messages see the Troubleshooting section.

WS68074,00016BC-19-17AUG16

On-Board Diagnostic (OBD) Tool

On-board diagnostic tool is not available on this tractor.

UP00731,0000302-19-11MAY17

Diagnostic Trouble Code (DTC)

IMPORTANT: When a DTC occurs; make note of operating conditions and information alert indicators. Contact your John Deere dealer for service assistance.



LV26008—UN—22AUG16

If a control unit software detects a malfunction or a status fault, a Diagnostic Trouble Code (DTC) is registered. A DTC number consist of the control unit software abbreviation, suspect parameter number (SPN), and a failure mode indicator number (FMI). A DTC identifies which machine system is experiencing a certain type of problem.

Software	SPN	FMI
ICC	2392	.05

Example of an Instrument Cluster Control (ICC) Diagnostic Trouble Code

If the DTC is accompanied by the STOP warning indicator, cease machine operation immediately and correct problem before resuming operation. See your John Deere dealer if the issue can not be resolved.



LV30672—UN—13NOV19

A—Display Mode Switch

For DTCs that are not accompanied by a Service Alert Indicator, press the display mode switch (A) to acknowledge the condition and resume the current operation. Resolve the DTC as soon as possible. An unresolved DTC can result in a STOP condition if left unresolved.

UP00731,00009F0-19-08NOV19

Come Home Mode

Come Home Mode allows the operator to move a tractor having mechanical problems.

NOTE: A 10A fuse (not supplied) is required to enter this mode. This fuse is referred to as the Come Home fuse in this procedure.

The Transmission Control Unit (TCU) must detect the Come Home fuse on initial ignition start-up before it enters come home mode. If the Come Home fuse is inserted after ignition start-up, the ignition must be powered off and back on before Come Home Mode will be activated.

Hydrostatic Transmission: The pedals must be in neutral position after Come Home Mode is activated before any motion is commanded.

PowrReverser Transmission: Reverser lever on dash must be in neutral position after Come Home Mode is activated before any motion is commanded.

Inserting the Come Home fuse generates a DTC (523966.01—Come Home Mode Procedure Detected). This code stays active until the Come Home mode fuse is removed.

Perform the following to enter the tractor into Come Home Mode:

1. With key switch OFF, insert the Come Home fuse (10A) into F03 in the tractor fuse panel.

NOTE: For more information on fuse location, see “Locating Fuses and Relays”.

2. Start engine.
3. When the instrument cluster displays “Seat”, toggle the seat switch (operator gets out of the seat and sits down again).
4. Display beeps five times and the Service Indicator Light illuminates.
5. Move tractor.

Vehicle Response in Come Home Mode:

- PTO Operation Disabled
- Hitch Assist Disabled
- LoadMatch Disabled
- MotionMatch Disabled
- eThrottle Disabled
- Cruise Control Disabled
- Creep2Reposition Disabled
- Shuttle Shifts Disabled
- Fault Codes Ignored
- Transmission calibration is not permitted

JC48530,00000B4-19-27SEP19

Specifications

Engine Specifications

Engine Specifications		
	3025E	3038E
Engine Manufacturer	Yanmar	Yanmar
Engine Model	3TNV88F-EPJT2	3TNV84T-BXJT4
Type	Diesel	Diesel
Gross Horsepower	18.2 kW (24.4 hp)	27.7 kW (37.1 hp)
Manufacturer's Estimated PTO Horsepower	13.0 kW (17.4 hp)	22.0 kW (29.5 hp)
Low Idle Speed	1200 rpm	950 rpm
Rated Engine Speed	2400 rpm	2600 rpm
High Idle	2550 rpm	2810 rpm
Operating Range	1200—2550rpm	950—2810 rpm
Engine Torque @ Rated Speed	72.4 N·m (53.4 lb·ft)	101.7 N·m (75.0 lb·ft)
Maximum Torque @ Rated Speed	87.8 N·m (64.8 lb·ft)	120 N·m (88.5 lb·ft)
Displacement	1.6 L (100.2 in ³)	1.5 L (91.3 in ³)
Cylinders	3	3
Bore and Stroke	88x90mm (3.46x3.54 in)	84x90mm (3.30x3.54 in)
Compression Ratio	19.1	19.1
Cooling System	Water Pump	Water Pump
Oil Filter	Single Element	Single Element
Air Cleaner	Dry Type with Safety Element	Dry Type with Safety Element
Starting Aid	Glow Plug	Glow Plug

NOTE: Engine Power rated according to SAE J1995.

UP00731,00009F1-19-03DEC19

Drivetrain Specifications

Drivetrain Specifications	
Transmission Type	Hydrostatic / four-wheel drive
Speeds	2 Range
Mechanical Front-Wheel Drive	Standard
Final Drive	Spur Gear
Rear Axle Weight Capacity (Continuous)	1200 kg (2640 lb)
Front Axle Weight Capacity (Continuous)	880 kg (1760 lb)

CM74493,00000EE-19-12SEP18

Hydraulic System Specifications

Hydraulic System Specifications	
Pump Type	Tandem Gear
Hydrostatic Pump Type	PV Axial Piston
Implement and Steering Pump	Dual Gear
Working Pressure	17238 kPa (2500 psi)
Charge Pressure	800 kPa (116 psi)
Loop Pressure	34.5 MPa (5000 psi)
Implement Flow @ Max Speed	20.2 L/min (5.3 gpm)
Steering Flow @ Max Speed	15 L/min (4 gpm)
Total Pump Flow	35.2 L/min (9.3 gpm)

Specifications

CM74493,00000EF-19-12SEP18

Electrical System

Electrical System Specification	
Type	12 Volt
Battery Size	500 Cold Cranking Amps @ -18°C (0°F)
Alternator	55 amp

CM74493,00000F0-19-12SEP18

Fluid Capacities

Fluid Capacities	
Fuel Tank	28.5 L (7.5 gal)
Cooling System	3025E - 4.9 L (5.2 qt) 3038E - 5.2 L (5.5 qt)
Crankcase with Filter	4.3 L (4.5 qt)
Transmission and Hydraulic System	20.8 L (5.5 gal)
Front Axle	3.8 L (4.0 qt)

UP00731,0000A0C-19-03DEC19

Ground Speeds

NOTE: All ground speed calculations shown are with machine equipped with standard 15.00-19.5 4PR R4 rear tires and operated at 2500 engine rpm.

Ground Speeds	
Forward and Reverse Low Range	9.7 km/h (6.0 mph)
Forward and Reverse High Range	20.8 km/h (12.9 mph)

CM74493,00000F2-19-12SEP18

Dimensions

NOTE: Machine equipped with standard 15.00-19.5 4PR R4 rear tires and 25x8.50-14 4PR R4 front tires.

Dimensions	
Wheelbase	1594 mm (62.8 in)
Overall Length with 3-point Hitch	2945 mm (115.9 in)
Overall Width @ Minimum Rear Tread (Standard R1 Tires)	1445 mm (56.9 in)
Overall Width @ Maximum Rear Tread (Larger R4 Tires)	1569 mm (61.7 in)

CM74493,00000F3-19-12SEP18

Specifications

Height from Ground

NOTE: Machine equipped with R4 tires.

Height from Ground	
To Top of ROPS	2422 mm (95.3 in)

CM74493.00000F4-19-12SEP18

Ground Clearance

Ground Clearance	
Front Axle Clearance (R4 Tires)	324 mm (12.7 in)

CM74493.00000F5-19-12SEP18

Machine Weight

NOTE: Machine equipped with a ROPS, 3-point hitch, standard R4 tires and all fluids.

Machine Weight	
Base tractor	1028 kg (2266 lb)
Base tractor with loader	1348 kg (2972 lb)

CM74493.00000F6-19-12SEP18

3-Point Hitch Specification

3-Point Hitch	
3-Point Hitch Type	Category 1
3-Point Hitch Lift Capacity—61 cm (24 in) behind link arms	615 kg (1356 lb)

CM74493.00000F7-19-12SEP18

Coupling Devices

Coupling devices		Drawbar
Maximum vertical load (daN)		400 kg
Towable Mass (kg)	Unbraked	1300 kg
	Independently braked	1350 kg
	Inertia braked	2000 kg
	Assisted braked	---

CM74493.00000F8-19-12SEP18

Sound Level

Open Operator Station Tractors—Maximum Noise Level, High Idle, No Load	85.8 dB(A)	Measurement to Test Method 2 in accordance with (EU) 1322/2014 Annex XIII
--	------------	---

UP00731,00005C0-19-22AUG18

Seat Vibration

Measured at the seat (awS), equivalent to $\leq 1.25 \text{ m/s}^2$.

Seat Vibration		
Item	Measurement	Specification
Vibration at Seat	Heavy Operator (95 kg [210 lb])	1.06 m/s ²
	Light Operator (59 kg [130 lb])	1.24 m/s ²
Vibration at Air Ride Seat	Heavy Operator (95 kg [210 lb])	1.00 m/s ²
	Light Operator (59 kg [130 lb])	1.14 m/s ²

To meet this vibration specification, use only the John Deere seat that has been approved and is compatible with this tractor.

CM74493,00000FA-19-13SEP18

How to Calculate Maximum Permissible Download on Trailer Hitch

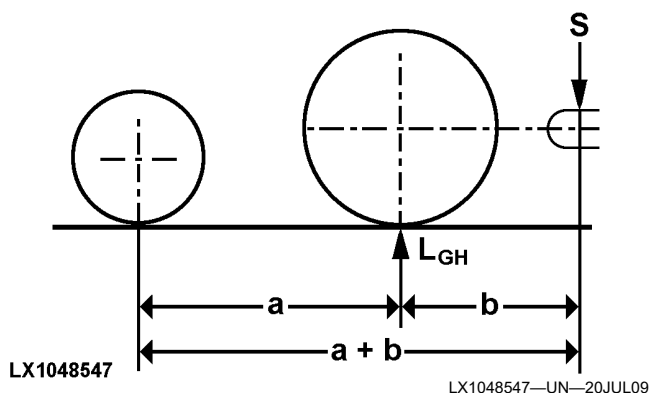

LI	kg	LI	kg	LI	kg	LI	kg
93 . .	650	114 . .	1180	135 . .	2180	156 . .	4000
94 . .	670	115 . .	1215	136 . .	2240	157 . .	4125
95 . .	690	116 . .	1250	137 . .	2300	158 . .	4250
96 . .	710	117 . .	1285	138 . .	2360	159 . .	4375
97 . .	730	118 . .	1320	139 . .	2430	160 . .	4500
98 . .	750	119 . .	1360	140 . .	2500	161 . .	4625
99 . .	775	120 . .	1400	141 . .	2575	162 . .	4750
100 . .	800	121 . .	1450	142 . .	2650	163 . .	4875
101 . .	825	122 . .	1500	143 . .	2725	164 . .	5000
102 . .	850	123 . .	1550	144 . .	2800	165 . .	5150
103 . .	875	124 . .	1600	145 . .	2900	166 . .	5300
104 . .	900	125 . .	1650	146 . .	3000	167 . .	5450
105 . .	925	126 . .	1700	147 . .	3075	168 . .	5600
106 . .	950	127 . .	1750	148 . .	3150	169 . .	5800
107 . .	975	128 . .	1800	149 . .	3250	170 . .	6000
108 . .	1000	129 . .	1850	150 . .	3350	171 . .	6150
109 . .	1030	130 . .	1900	151 . .	3450	172 . .	6300
110 . .	1060	131 . .	1950	152 . .	3550	173 . .	6500

As a general rule, SI A8 implies a top speed of 40 km/h (25 mph), while SI B implies a top speed of 50 km/h (31 mph). If the SI is different, the manufacturer's instructions apply.

Calculate maximum trailer hitch download as follows:

$$S = \frac{(H_{\max} - L_{GH}) * a}{a + b}, \text{ where}$$

- H_{\max} = the smaller value from 2*load capacity of a tire on the rear axle and the maximum permissible rear axle load in kg
- L_{GH} = the mass in kg acting on the ground through the rear wheels (to be ascertained by weighing)
- a = the wheelbase (the horizontal distance between the front and rear axles)

Calculation of maximum permissible download at the trailer hitch in relation to Load Index (LI)

- The load index can be read on the sidewall of the tire. If the index is not provided, refer to the tire's load capacity as quoted by the tire manufacturer.
- The load index is quoted in conjunction with a Speed index (SI)
- As a rule, the load capacity of the tire in kg can be derived directly from the LI; see the following table:

LI	kg	LI	kg	LI	kg	LI	kg
90 . .	600	111 . .	1090	132 . .	2000	153 . .	3650
91 . .	615	112 . .	1120	133 . .	2060	154 . .	3750
92 . .	630	113 . .	1150	134 . .	2120	155 . .	3875

Specifications

b = the rear overhang (the horizontal distance between the center of the rear axle and center of the hitch point)

D = D value of hitch
 G = Gravitational constant 9.81 m/s²
 A = Tractor mass
 B = Trailer mass

Example of how to calculate maximum trailer hitch download:

Given that: Empty mass on rear axle $L_{GH} = 1800$ kg
 Wheelbase $a = 2100$ mm
 Overhang $b = 600$ mm
 Tire marking = 130A8
 Maximum permitted speed of tractor = 40 km/h (25 mph)
 Permissible rear axle load = 3500 kg
 $H_{max} = 3500$ kg
 (1900 kg * 2 = 3800 kg, rear axle load = 3500 kg)

$$S = \frac{(3500 \text{ kg} - 1800 \text{ kg}) * 2100 \text{ mm}}{2100 \text{ mm} + 600 \text{ mm}} = 1322 \text{ kg}$$

CAUTION: At least 20% of the vehicle's total unladen mass must be on the front axle.
 Trailer hitch download must not exceed the trailer hitch limit specified by the manufacturer.

UP00731,0000192-19-13SEP18

How to Calculate Permissible Mass Calculating permissible tractor mass and permissible trailer mass on the basis of the D value

EC-approved, dynamically tested hitches are always provided with a D value. This is calculated as follows:

$$D = \frac{G * A * B}{A + B}, \text{ where}$$

To calculate trailer mass for a given D value and a given tractor mass, and to calculate tractor mass for a given D value and a given trailer mass, use the following formulas:

$$\text{Tractor mass } A = \frac{D * B}{G * B - D}$$

$$\text{Trailer mass } B = \frac{D * A}{G * A - D}$$

*NOTE: If when calculating A the product of G*B is less than the D value, or if when calculating B the product of G*A is less than the D value, then the result of this calculation is negative. Even so, the D value is sufficient for every combination of tractor mass and trailer mass.*

Example of how to calculate permissible trailer mass:

Given that: D value, $D = 55 \text{ kN} = 55000 \text{ N}$
 Tractor mass $A = 7000 \text{ kg}$

$$B = \frac{55000 \text{ N} * 7000 \text{ kg}}{9.81 \text{ m/s}^2 * 7000 \text{ kg} - 55000 \text{ N}} = 28163 \text{ kg}$$

Pay close attention to permissible towed mass and tractor mass!

UP00731,0000193-19-13SEP18

Unified Inch Bolt and Screw Torque Values

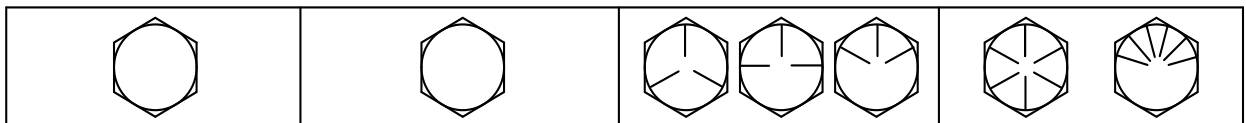

TS1671—UN—01MAY03

Specifications

Bolt or Screw Size	SAE Grade 1 ^a				SAE Grade 2 ^b				SAE Grade 5, 5.1 or 5.2				SAE Grade 8 or 8.2			
	Hex Head ^c		Flange Head ^d		Hex Head ^c		Flange Head ^d		Hex Head ^c		Flange Head ^d		Hex Head ^c		Flange Head ^d	
	N·m	lb·in	N·m	lb·in	N·m	lb·in	N·m	lb·in	N·m	lb·in	N·m	lb·in	N·m	lb·in	N·m	lb·in
1/4	3.1	27.3	3.2	28.4	5.1	45.5	5.3	47.3	7.9	70.2	8.3	73.1	11.2	99.2	11.6	103
													N·m	lb·ft	N·m	lb·ft
5/16	6.1	54.1	6.5	57.7	10.2	90.2	10.9	96.2	15.7	139	16.8	149	22.2	16.4	23.7	17.5
									N·m	lb·ft	N·m	lb·ft				
3/8	10.5	93.6	11.5	102	17.6	156	19.2	170	27.3	20.1	29.7	21.9	38.5	28.4	41.9	30.9
					N·m	lb·ft	N·m	lb·ft								
7/16	16.7	148	18.4	163	27.8	20.5	30.6	22.6	43	31.7	47.3	34.9	60.6	44.7	66.8	49.3
	N·m	lb·ft	N·m	lb·ft												
1/2	25.9	19.1	28.2	20.8	43.1	31.8	47	34.7	66.6	49.1	72.8	53.7	94	69.3	103	75.8
9/16	36.7	27.1	40.5	29.9	61.1	45.1	67.5	49.8	94.6	69.8	104	77	134	98.5	148	109
5/8	51	37.6	55.9	41.2	85	62.7	93.1	68.7	131	96.9	144	106	186	137	203	150
3/4	89.5	66	98	72.3	149	110	164	121	230	170	252	186	325	240	357	263
7/8	144	106	157	116	144	106	157	116	370	273	405	299	522	385	572	422
1	216	159	236	174	216	159	236	174	556	410	609	449	785	579	860	634
1-1/8	305	225	335	247	305	225	335	247	685	505	751	554	1110	819	1218	898
1-1/4	427	315	469	346	427	315	469	346	957	706	1051	775	1552	1145	1703	1256
1-3/8	564	416	618	456	564	416	618	456	1264	932	1386	1022	2050	1512	2248	1658
1-1/2	743	548	815	601	743	548	815	601	1665	1228	1826	1347	2699	1991	2962	2185

The nominal torque values listed are for general use only with the assumed wrenching accuracy of 20%, such as a manual torque wrench. DO NOT use these values if a different torque value or tightening procedure is given for a specific application. For lock nuts, for stainless steel fasteners, or for nuts on U-bolts, see the tightening instructions for the specific application.

Replace fasteners with the same or higher property class. If higher property class fasteners are used, tighten these to the strength of the original.

- Make sure that fastener threads are clean.
- Apply a thin coat of Hy-Gard™ or equivalent oil under the head and on the threads of the fastener, as shown in the following image.
- Be conservative with the amount of oil to reduce the potential for hydraulic lockup in blind holes due to excessive oil.
- Properly start thread engagement.

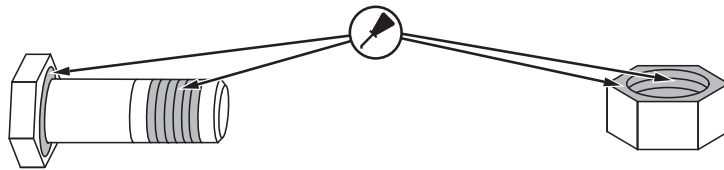

TS1741—UN—22MAY18

^aGrade 1 applies for hex cap screws over 6 in (152 mm) long, and for all other types of bolts and screws of any length.

^bGrade 2 applies for hex cap screws (not hex bolts) up to 6 in (152 mm) long.

^cHex head column values are valid for ISO 4014 and ISO 4017 hex head, ISO 4162 hex socket head, and ISO 4032 hex nuts.

^dHex flange column values are valid for ASME B18.2.3.9M, ISO 4161, or EN 1665 hex flange products.

DX, TORQ1-19-30MAY18

Metric Bolt and Screw Torque Values

TS1742—UN—31MAY18

Specifications

Bolt or Screw Size	Class 4.8				Class 8.8 or 9.8				Class 10.9				Class 12.9				
	Hex Head ^a		Flange Head ^b		Hex Head ^a		Flange Head ^b		Hex Head ^a		Flange Head ^b		Hex Head ^a		Flange Head ^b		
	N·m	lb·in	N·m	lb·in	N·m	lb·in	N·m	lb·in	N·m	lb·in	N·m	lb·in	N·m	lb·in	N·m	lb·in	
M6	3.6	31.9	3.9	34.5	6.7	59.3	7.3	64.6	9.8	86.7	10.8	95.6	11.5	102	12.6	112	
										N·m	lb·ft	N·m	lb·ft	N·m	lb·ft	N·m	lb·ft
M8	8.6	76.1	9.4	83.2	16.2	143	17.6	156	23.8	17.6	25.9	19.1	27.8	20.5	30.3	22.3	
			N·m	lb·ft	N·m	lb·ft	N·m	lb·ft									
M10	16.9	150	18.4	13.6	31.9	23.5	34.7	25.6	46.8	34.5	51	37.6	55	40.6	60	44.3	
			N·m	lb·ft													
M12	—	—	—	—	55	40.6	61	45	81	59.7	89	65.6	95	70.1	105	77.4	
M14	—	—	—	—	87	64.2	96	70.8	128	94.4	141	104	150	111	165	122	
M16	—	—	—	—	135	99.6	149	110	198	146	219	162	232	171	257	190	
M18	—	—	—	—	193	142	214	158	275	203	304	224	322	245	356	263	
M20	—	—	—	—	272	201	301	222	387	285	428	316	453	334	501	370	
M22	—	—	—	—	365	263	405	299	520	384	576	425	608	448	674	497	
M24	—	—	—	—	468	345	518	382	666	491	738	544	780	575	864	637	
M27	—	—	—	—	683	504	758	559	973	718	1080	797	1139	840	1263	932	
M30	—	—	—	—	932	687	1029	759	1327	979	1466	1081	1553	1145	1715	1265	
M33	—	—	—	—	1258	928	1398	1031	1788	1319	1986	1465	2092	1543	2324	1714	
M36	—	—	—	—	1617	1193	1789	1319	2303	1699	2548	1879	2695	1988	2982	2199	

The nominal torque values listed are for general use only with the assumed wrenching accuracy of 20%, such as a manual torque wrench. DO NOT use these values if a different torque value or tightening procedure is given for a specific application. For lock nuts, for stainless steel fasteners, or for nuts on U-bolts, see the tightening instructions for the specific application.

Replace fasteners with the same or higher property class. If higher property class fasteners are used, tighten these to the strength of the original.

- Make sure that fastener threads are clean.
- Apply a thin coat of Hy-Gard™ or equivalent oil under the head and on the threads of the fastener, as shown in the following image.
- Be conservative with the amount of oil to reduce the potential for hydraulic lockup in blind holes due to excessive oil.
- Properly start thread engagement.

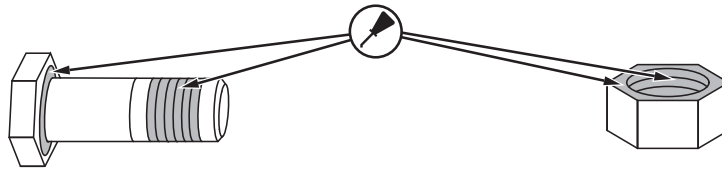

TS1741—UN—22MAY18

^aHex head column values are valid for ISO 4014 and ISO 4017 hex head, ISO 4162 hex socket head, and ISO 4032 hex nuts.

^bHex flange column values are valid for ASME B18.2.3.9M, ISO 4161, or EN 1665 hex flange products.

DX,TORQ2-19-30MAY18

Identification Numbers

Product Identification Information

1	L	V	3	0	4	6	R	#	#	A	1	0	0	0	0	1
WMC	Build Factory	Machine Series	Engine Hp			Machine Family	Check Letter	Calendar Year	Model Year	Operator Station Identifier	Build Sequence					
		Model Number			Serial Number											

Product Identification Number (PIN) is made of various alphabetical and numeric characters. Characters represent multiple machine attributes like manufacture location, model number, manufacture date, model year, machine configurations, serial number, and more.

Use machine PIN when communicating with John Deere Dealer.

Each machine has its own unique Product Identification Number (PIN). The PIN number is broken down as follows:

WMC: World Manufacturing Code.

Build Factory: represents manufacturing location.

Machine Series: represents tractor series.

Engine Hp: represents approximate engine horsepower.

Machine Family: represents overall machine configuration.

Check Letter: calculated based on values and positions of the other characters in the PIN.

Calendar Year = represents calendar year of manufacture (2010 = A, 2031 = 1, 2041 = A again).

Model Year = year of new product release or year of updates to existing product.

Operator Station = represents style of cab or open operation station.

Build Sequence = represents consecutive number of machines built with same machine series through operator station.

Model Number: made up of series, Hp, and family; example shown 3046R.

Serial Number: made up of model year, operator station, and build sequence.

UP00731,0000227-19-30JAN18

Record Identification Numbers

Compact Utility Tractor

PIN (KL300001—)

If you need to contact an Authorized Service Center for information on servicing, always provide the product model and identification numbers.

You will need to locate the identification numbers for the

product. Record the information in the spaces provided below.

Date of Purchase:

Dealer Name:

Dealer Phone:

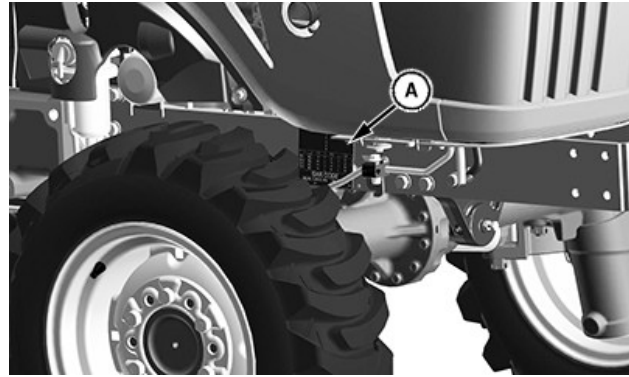

LV29161—UN—23AUG17

Product Identification Number Plate

Product Identification Number (A):

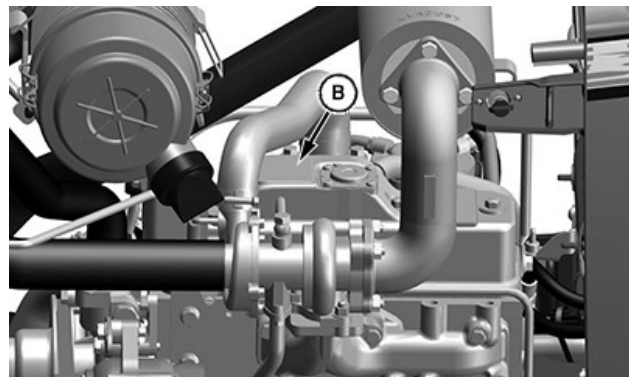

LV29474—UN—03OCT17

Engine Serial Number (B):

UP00731,00009F2-19-20NOV19

Certification and Warranty

Warranty

See your local John Deere dealer for warranty information.

UP00731,00002A6-19-25JUL16

Service Records

Every 10 Hour Service

SERVICE PROCEDURE	
<input type="checkbox"/> Check safety interlock system	<input type="checkbox"/> Radiator Coolant Level
<input type="checkbox"/> Check Engine Oil Level	<input type="checkbox"/> Lubricate Grease Points (Wet Conditions)
<input type="checkbox"/> Check Transmission Oil Level	
<input type="checkbox"/> Clean Air Filter Rubber Dust Valve	

Hours:	Comments:	Dealer's Stamp
Date:		
Work Carried Out By:		

SK35149,00011D9-19-01AUG17

Every 50 Hour Service

SERVICE PROCEDURE	
<input type="checkbox"/> Check Front Axle Oil Level	<input type="checkbox"/> Lubricate Grease Points (Normal Conditions)
<input type="checkbox"/> Lubricate 3-Point Hitch	

Hours:	Comments:	Dealer's Stamp
Date:		
Work Carried Out By:		

SK35149,00011DA-19-01AUG17

Every 200 Hour Service

SERVICE PROCEDURE	
<input type="checkbox"/> Inspect Alternator Belt	<input type="checkbox"/> Check Wheel Bolt Torque
<input type="checkbox"/> Change Transmission Oil and Filter	

Hours:	Comments:	Dealer's Stamp
Date:		
Work Carried Out By:		

UP00731,00009EA-19-01NOV19

Service Records

Every 400 Hour Service

SERVICE PROCEDURE	
<input type="checkbox"/> Drain water from fuel tank and replace fuel filter	<input type="checkbox"/> Change transmission oil and filter
<input type="checkbox"/> Change Engine Oil and Filter	

Hours: Date: Work Carried Out By:	Comments:	Dealer's Stamp
---	-----------	----------------

UP00731,00009EB-19-01NOV19

Every 600 Hour Service

SERVICE PROCEDURE	
<input type="checkbox"/> Check Engine High and Low Idle Speeds	<input type="checkbox"/> Check Axle Thrust Bolt Torque
<input type="checkbox"/> Service Air Filter Element and Hoses	<input type="checkbox"/> Check Brake Adjustment
<input type="checkbox"/> Check Front Axle Oil	

Hours: Date: Work Carried Out By:	Comments:	Dealer's Stamp
---	-----------	----------------

SK35149,00011DD-19-01AUG17

Yearly

SERVICE PROCEDURE	
<input type="checkbox"/> Change Engine Oil and Filter	<input type="checkbox"/> Drain Water from Fuel Tank and Replace Fuel Filter
<input type="checkbox"/> Check Wheel Bolt Torque	<input type="checkbox"/> Check all Hoses and Clamps

Hours: Date: Work Carried Out By:	Comments:	Dealer's Stamp
---	-----------	----------------

SK35149,00011DE-19-01AUG17

Service Records

Every 1000 Hour Service

SERVICE PROCEDURE	
<input type="checkbox"/> Check Engine Valve Clearance. See your John Deere Dealer	

Hours: Date: Work Carried Out By:	Comments:	Dealer's Stamp
---	-----------	----------------

SK35149,00011DF-19-01AUG17

Every 2000 Hour Service or Every Two Years

SERVICE PROCEDURE	
<input type="checkbox"/> Drain, Flush and Refill Engine Cooling System ^a	

^aWhen coolant is NOT checked annually or NOT serviced with the pre-diluted John Deere Cool-Gard II

Hours: Date: Work Carried Out By:	Comments:	Dealer's Stamp
---	-----------	----------------

SK35149,00011E0-19-13NOV19

Every 6000 Hour Service or Every Six Years

SERVICE PROCEDURE	
<input type="checkbox"/> Drain, Flush and Refill Engine Cooling System ^a	

^aWhen coolant is checked annually and serviced with the pre-diluted John Deere Cool-Gard II

Hours: Date: Work Carried Out By:	Comments:	Dealer's Stamp
---	-----------	----------------

SK35149,00011E1-19-13NOV19

Change of Ownership

Serial Number																		
Engine Number																		

Service Records

Previous Owner:
Address:
Purchase Date:
Hours at Purchase:

Machine Model:
Registration No.:
New Owner:
Address:
Dealer's Stamp (only if sold through dealer)

UP00731,0000233-19-22FEB18

Change of Ownership

Serial Number																			
Engine Number																			

Previous Owner:
Address:
Purchase Date:
Hours at Purchase:

Machine Model:
Registration No.:
New Owner:
Address:
Dealer's Stamp (only if sold through dealer)

UP00731,0000234-19-22FEB18

Change of Ownership

Serial Number																		
Engine Number																		

Previous Owner:
Address:
Purchase Date:
Hours at Purchase:

Machine Model:
Registration No.:
New Owner:
Address:
Dealer's Stamp (only if sold through dealer)

Index

A	
Additional Equipment, Maintenance	280B-1
Additional Equipment, Operation	80B-1
Air Filter Elements, Service	230-1
Air Filter Intake Hoses and Clamps, Check	230-2
Alternator Belt, Service	220-2
Attachments, Operate	70A-1
Avoid static electricity risk when fueling	00A-4
Axle Trunnion, Lubricating	250B-2
Axle, Front, Change Oil	250B-1
Axle, Front, Check Oil Level	250B-1
Axle, Front, Thrust Bolt	250B-2
B	
Ballast Machine	80A-1
Ballast to Work Load, Match	280A-1
Battery and Terminals, Clean	240-1
Battery Booster, Use	240-2
Battery Handling, Safety	
Safety, Battery Handling	00A-12
Battery, Remove and Install	240-1
Bolt and screw torque values	
Metric	400-6
Unified inch	400-5
Brake Pedal, Operate	
Differential Lock Pedal	60-1
Brake, Operate Park	60-1
Bulb, Replace Headlight	240-2
C	
Carbon Dioxide Emissions	200A-1
Cold Weather Starting Aids	20-2
Come Home Mode	300A-2
Controls, Foot-Operated Controls	10-1
Controls, Front Console	10-1
Controls, Left-Hand Console	10-4
Controls, Right-Hand Console	10-3
Coolant	
Additional information	200A-5
Diesel Engine	
Light Duty	200A-4
Testing	200A-5
Warm temperature climates	200A-4
Coolant Level, Check	230-3
Cooling System, Drain and Flush	230-3
Cooling System, Fill	230-4
D	
Diagnostic Trouble Code (DTC) Mode	300A-1
Diesel engines, cold weather effect	200A-2
Diesel fuel, testing	200A-2
Diesel Fuel, Using	200A-1
Differential Lock Pedal, MFWD Controls, Seat	
Adjustment	10-5
Differential Lock, Use	50C-1
Dimensions	400-2
Display, Information	10-9
Display, On Board Diagnostic	300A-1
Draft Links, Use	70A-2
Drawbar, Operate	70A-4
Drivetrain Specifications	400-1
Dust Unloading Valve, Clean	220-2
E	
Effect of cold weather on diesel engines	200A-2
Electrical Specifications	400-2
Electrical System Troubleshooting	300-4
Emissions	
Required language	
EPA	220-1
Emissions Performance	
Tampering	200A-1
Engine Compartment, Clean	220-3
Engine Specifications	400-1
Engine Troubleshooting	300-1
Engine, Start	20-1
Engine, Start a Stalled	20-3
Engine, Stop	20-3
Engine, Warm and Idle	20-2
Exhaust Filter, Safety	
Safety, Exhaust Filter	00A-14
Exit Machine, and Enter	90-1
F	
Filter (3025E), Replacing Fuel	230-2
Filter, Change Engine Oil and	220-2
Fluid Capacities	400-2
Front Axle Oil	200A-6
Front Wheel Drive(MFWD), Use Mechanical ..	50B-1
Fuel	
Handling and storing	200A-2
Fuel Shut- Off Valve, Operate	20-1
Fuel Shut- Off Valve, Using	30-1
Fuel Storage	100-2
Fuel Tank, Drain and Flush	230-3
Fuel Tank, Fill	30-1
Fuse and Relays, Size	
Fuse and Relays, Function	240-3
Fuses and Relays, Locating	240-3
Fuses, Replacing	240-3
G	
Ground Speeds	400-2
H	
Hardware torque values	
Metric	400-6
Unified inch	400-5
Height from Ground	400-3
Hood Cowl, Removal and Installation	290-1

Index

Hood, Raise and Lower 290-1
Hydraulic Maintenance 270-1
Hydraulic Oil 200A-6
Hydraulic Specifications 400-1
Hydraulics Information 70-1

I

Identification Numbers, Record 400A-1
Implement Codes 80A-1
Implement Front-to-Rear, Level 70A-3
Implement Hydraulic Hoses, Connect 70B-1
Implement Side-to-Side Sway, Adjust 70A-3
Implement Side-to-Side, Level 70A-3
Inflation Pressure 80-1
Information Display Fault Messages 300-1
Installation, Front Loader
 Front Loader, Installation 80B-1
Instrument Cluster 10-6
Isolation / Battery, Battery 100-3

K

Key Switch, Operate 20-1

L

Lift Points for Jacking up Tractor 280-2
Light Bulbs, Replacing Tail/Turn 240-2
Lights, Road, Work and Warning 40-1
Lights, Turn Signal and Hazard 40-1
Liquid Weight in Tires, Use 80A-2
Load Capacity of Tires, Ascertaining 80-1
Lubricants, safety 200A-3

M

Machine Troubleshooting 300-5
Machine, Drive 50-1
Maintenance Interval Chart - Every 600 Hours - Every
 6000 Hours 200-1
Maintenance Interval Chart, Daily to Every 400 Hours
 200-1
Maintenance, Brake 260-1
Maintenance, Controls and Instruments 210-1
Maintenance, Drivetrain 250-1
Maintenance, PTO 250D-1
Maintenance, Steering 260-1
Metal Surfaces, Repair and Clean 200-3
Metric bolt and screw torque values 400-6
MFWD Oil 200A-6

N

Nozzles, Fuel Injection 230-3

O

Oil and Filter, Change Transmission 250A-1
Oil Level, Check Engine 220-1

Oil Level, Check Transmission 250A-1
Oil, Engine 200A-3
Oil, Warming Hydraulic System 70-1
Optional Front Weight, Use 80A-2
Optional Rear Ballast Box, Use 80A-2

P

Plastic And Painted Surfaces, Avoid Damage To 200-2
Plastic Surfaces, Clean 200-3
Power Port Outlet, Use 40-2
Power- Take- Off (PTO), Operate Rear 50D-1
Prepare Machine for Storage 100-2
Product Identification Information 400A-1
Pump, Fuel Injection 230-3
Push or Tow Machine 100-1

R

Radiator Hoses and Clamps, Check 230-5
Radiator, Fuel and Transmission Cooling Fins, Clean
 230-5
Rate-of-drop, Operate 70A-2
Rear Axle 250C-1
Refueling, avoid static electricity risk 00A-4
Roll Over Protection Structure (ROPS) 90-1
Rops, Inspect for Loose Hardware 290-2

S

Safety
 Protect against noise 00A-2
 Rotating drivelines, stay clear 00A-5
 Safe maintenance, practice 00A-13
 Tires, service safely 00A-17
 Towed equipment, transport at safe speeds 00A-9
 Tractor, operating safely 00A-6
 Use caution on slopes, uneven terrain, and rough
 ground 00A-10
Safety, Avoid High-Pressure Fluids
 Avoid High-Pressure Fluids 00A-17
Safety, Fire Prevention
 Fire Prevention 00A-3
Safety, Forestry Operations
 Limited Use in Forestry Operation 00A-7
Safety, Handle Fuel Safely, Avoid Fires
 Avoid Fires, Handle Fuel Safely 00A-2
Safety, lubricants 200A-3
Safety, ROPS
 ROPS, Keep Installed Properly 00A-4
Safety, Steps and Handholds
 Use Steps and Handholds Correctly 00A-5
Safety, Tightening Wheel Retaining Bolts/Nuts
 Tightening Wheel Retaining Bolts/Nuts 00A-17
Screens, Clean Front and Side Grille 220-3
Seat Belt, Use 90-1
Seat, Adjust 90-1
Selective Control Valve (SCV, Operate 70B-1

Selective Control Valve (SCV) Lock Lever, Operate .. 70B-1, 70B-3
 Selective Control Valve, Check 270B-1
 Selective Control Valve(SCV), Operate Hydraulic
 Dual 70B-2
 Service Alert and Information Display 300A-1
 Service Electrical 240-1
 Service Records
 Change of Ownership 500-3, 500-5
 Service Records, 1000 Hour 500-3
 Service Records, 6000 Hour
 Service Records, Six Years 500-3
 Service, As Required 200B-1
 Side Panels, Remove and Install 290-1
 Signal words, understand 00A-1
 Sound Level 400-4
 Specifications on Tires 80-1
 Steering Troubleshooting 300-7
 Storage, Remove Machine From 100-3
 Store Safety 100-2
 Storing fuel 200A-2
 Switch, Display Mode 10-9

T

Test Safety Interlock System Before Startup 200-2
 Testing diesel fuel 200A-2
 Throttle, Operate 20-1
 Tire Capacity, Front and Rear 80-2
 Tire Combinations 80-2
 Tire Inflation Pressure Chart 280-1
 Tire Labeling 80-1
 Tire Pressure, Check 280-1
 Tire Rolling Direction, Front, Select 280-2
 Tires, service safely 00A-17
 Toe-In, Check
 Toe-In, Adjust 260-1
 Tool, On-Board Diagnostic (OBD) 300A-1
 Torque charts
 Metric 400-6
 Unified inch 400-5
 Tow Loads 100-2
 Towed equipment, transport at safe speeds ... 00A-9
 Traction Assist, Use 50C-1
 Tractor, operating safely 00A-6
 Trailer Hitch, Maximum Permissible Download
 Permissible Downloads 400-4
 Trailer Hitch, Maximum Permissible Mass
 Permissible Mass 400-5
 Transmission, Operate 50A-1
 Transport Machine 100-1
 Transport Machine on Trailer 100-1

U

Unified inch bolt and screw torque values 400-5

V

Vibration, Seat 400-4

W

Weight, Machine 400-3
 Wheel Bolts and Hardware, Check 280-1
 Wheel Spacing and Tread Width, Changing 280-2
 Wheels, Remove and Install 280-1

John Deere Service

John Deere Is At Your Service



TS201—UN—15APR13

CUSTOMER SATISFACTION is important to John Deere.

Our dealers strive to provide you with prompt, efficient parts and service:

–Maintenance and service parts to support your equipment.

–Trained service technicians and the necessary diagnostic and repair tools to service your equipment.

CUSTOMER SATISFACTION PROBLEM RESOLUTION PROCESS

Your John Deere dealer is dedicated to supporting your equipment and resolving any problem you may experience.

1. When contacting your dealer, be prepared with the following information:

–Machine model and product identification number

–Date of purchase

–Nature of problem

2. Discuss problem with dealer service manager.

3. If unable to resolve, explain problem to dealership manager and request assistance.

4. If you have a persistent problem your dealership is unable to resolve, ask your dealer to contact John Deere for assistance. Or contact the Ag Customer Assistance Center at 1-866-99DEERE (866-993-3373) or e-mail us at www.deere.com/en_US/ag/contactus/.

DX,IBC,2-19-02APR02

Technical Information

Technical information can be purchased from John Deere. Publications are available in print or CD-ROM format.

Orders can be made using one of the following:

- John Deere Technical Information Store: www.JohnDeere.com/TechInfoStore
- Call 1-800-522-7448
- Contact your John Deere dealer

Available information includes:



TS189—UN—17JAN89

PARTS CATALOGS list service parts available for your machine with exploded view illustrations to help you identify the correct parts. It is also useful in assembling and disassembling.



TS191—UN—02DEC88

OPERATOR'S MANUALS providing safety, operating, maintenance, and service information.

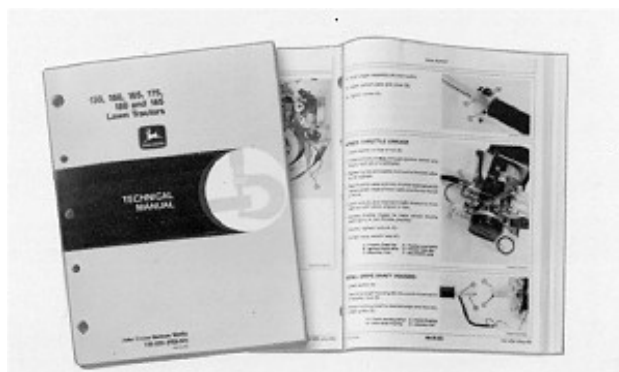

TS224—UN—17JAN89

TECHNICAL MANUALS outlining service information for your machine. Included are specifications, illustrated assembly and disassembly procedures, hydraulic oil flow diagrams, and wiring diagrams. Some products have separate manuals for repair and diagnostic

information. Some components, such as engines, are available in a separate component technical manual.



TS1663—UN—10OCT97

EDUCATIONAL CURRICULUM including five comprehensive series of books detailing basic information regardless of manufacturer:

- Agricultural Primer series covers technology in farming and ranching.
- Farm Business Management series examines “real-world” problems and offers practical solutions in the areas of marketing, financing, equipment selection, and compliance.
- Fundamentals of Services manuals show you how to repair and maintain off-road equipment.
- Fundamentals of Machine Operation manuals explain machine capacities and adjustments, how to improve machine performance, and how to eliminate unnecessary field operations.
- Fundamentals of Compact Equipment manuals provide instruction in servicing and maintaining equipment up to 40 PTO horsepower.

DX,SERVLIT-19-07DEC16
