

XUV560E, XUV560E S4 Gator™

Utility Vehicle



JOHN DEERE

OPERATOR'S MANUAL

XUV560E, XUV560E S4 Gator™ Utility Vehicle

OMUC12876 ISSUE F7 (ENGLISH)

CALIFORNIA

Proposition 65 Warning

Diesel engine exhaust and some of its constituents are known to the State of California to cause cancer, birth defects, and other reproductive harm.

If this product contains a gasoline engine:

WARNING

The engine exhaust from this product contains chemicals known to the State of California to cause cancer, birth defects or other reproductive harm.

The State of California requires the above two warnings.

Additional Proposition 65 Warnings can be found in this manual.

John Deere Horicon Works

North American Edition
Printed in U.S.A.



Introduction

Thank You for Purchasing a John Deere Product

We appreciate having you as a customer and wish you many years of safe and satisfied use of your machine.

MX00654,000020B-19-10MAY17

Using Your Operator's Manual

This manual is an important part of your machine and should remain with the machine when you sell it.

Reading your operator's manual will help you and others avoid personal injury or damage to the machine. Information given in this manual will provide the operator with the safest and most effective use of the machine. Knowing how to operate this machine safely and correctly will allow you to train others who may operate this machine.

If you have an attachment, use the safety and operating information in the attachment operator's manual, along with the machine operator's manual, to operate the attachment safely and correctly.

This manual and safety signs on your machine may also be available in other languages (see your authorized dealer to order).

Sections in your operator's manual are placed in a specific order to help you understand all the safety messages and learn the controls so you can operate this machine safely. You can also use this manual to answer any specific operating or servicing questions. A convenient index located at the end of this book will help you find needed information quickly.

The machine shown in this manual may differ slightly from your machine, but will be similar enough to help you understand our instructions.

RIGHT-HAND and LEFT-HAND sides are determined by facing in the direction that the machine will travel when going forward. When you see a broken line (-----), the item referred to is hidden from view.

Before delivering this machine, your dealer performed a predelivery inspection to ensure best performance.

MX00654,000020C-19-05JUN17

Special Messages

Your manual contains special messages to bring attention to potential safety concerns and machine damage, as well as helpful operating and servicing information. Please read all the information carefully to avoid injury and machine damage.

 **CAUTION: Avoid injury! This symbol and text highlight potential hazards or death to the operator or bystanders that may occur if the hazards or procedures are ignored.**

IMPORTANT: Avoid damage! This text is used to tell the operator of actions or conditions that might result in damage to the machine.

NOTE: General information is given throughout the manual that may help the operator in the operation or service of the machine.

MX00654,000020D-19-05JUN17

Attachments for Your Machine

There is a John Deere attachment or kit to make your new machine perform more tasks or be more versatile, whether your machine is a lawn tractor, compact utility tractor, or a utility vehicle.

You can check out the entire line of attachments for your machine at JohnDeere.com or ask your John Deere dealer. From aerators to electric lift kits to tillers, there is a John Deere attachment or kit to fill every need.

OUMX068,000051C-19-05JUN17

Service Literature

If you would like a copy of the Parts Catalog or Technical Manual for this machine, visit The John Deere Technical Information Store at:

https://techpubs.deere.com/?cid=VURL_TechInfoStore

or call:

- **U.S. & Canada:** 1-800-522-7448.
- **All Other Regions:** Your John Deere dealer.

TH84124,0000199-19-05JUN17

Parts

We recommend John Deere quality parts and lubricants, available at your John Deere dealer.

When you order parts, your John Deere dealer needs the serial number or product identification number (PIN) for your machine or attachment. These are the numbers that you recorded in the Product Identification section of this manual.

Order Service Parts Online

Visit <http://JDParts.deere.com> for your Internet connection to parts ordering and information.

TC00531,00000E9-19-06MAR15

Contents

Product Identification.....	4
Safety Labels Text.....	5
Safety Labels No-Text.....	13
Safety.....	21
Machine Cleanout.....	30
Operating Controls.....	32
Operating.....	33
Optional Attachments & Kits.....	48
Service Intervals.....	51
Service Lubrication.....	53
Service Engine.....	54
Service Transmission.....	62
Service Steering & Brakes.....	68
Service Electrical.....	70
Service Miscellaneous.....	74
Troubleshooting.....	83
Storage.....	85
Specifications.....	87
Warranty.....	90
John Deere Quality Statement.....	95
Service Record.....	97

Original Instructions. All information, illustrations and specifications in this manual are based on the latest information available at the time of publication. The right is reserved to make changes at any time without notice.

Product Identification

Record Identification Numbers

XUV560E, XUV560E S4

OUMX068,0001291-19-10MAY17

PIN (010001-)

If you need to contact an Authorized Service Center for information on servicing, always provide the product model and identification numbers.

You will need to locate the identification numbers for the product. Record the information in the spaces provided below.



MXT008842—UN—03SEP13



MXAL47279—UN—16APR13

DATE OF PURCHASE:

DEALER NAME:

DEALER PHONE:

PRODUCT IDENTIFICATION NUMBER (A):

ENGINE SERIAL NUMBER (B):

Safety Labels Text

Safety Label Location—XUV560 (Bucket Seat)

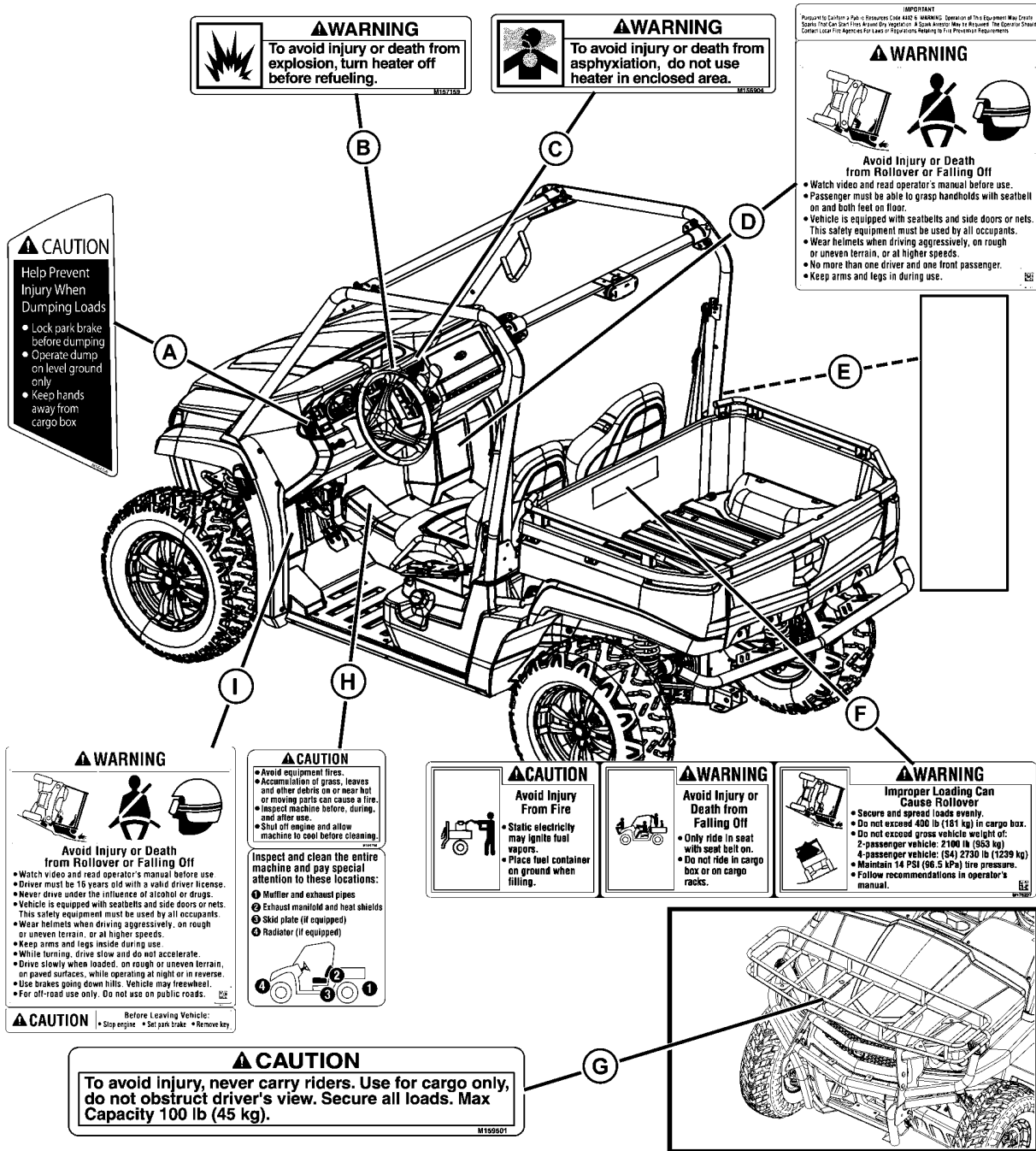

MXT016167—UN—04NOV15

- A—CAUTION M164706 (Machines with Power Lift)
- B—WARNING M157159 (On Optional Heater)
- C—WARNING M156904 (On Optional Heater)
- D—WARNING M17112
- E—Protective Structure Safety and Certification M176766

- F—CAUTION/WARNING M176227
- G—CAUTION M159501 (On Optional Front Rack)
- H—CAUTION M165798
- I—WARNING M171711

OUMX068,0000E58-19-04NOV15

Safety Labels Text

Safety Label Location—XUV560 (Bench Seat)

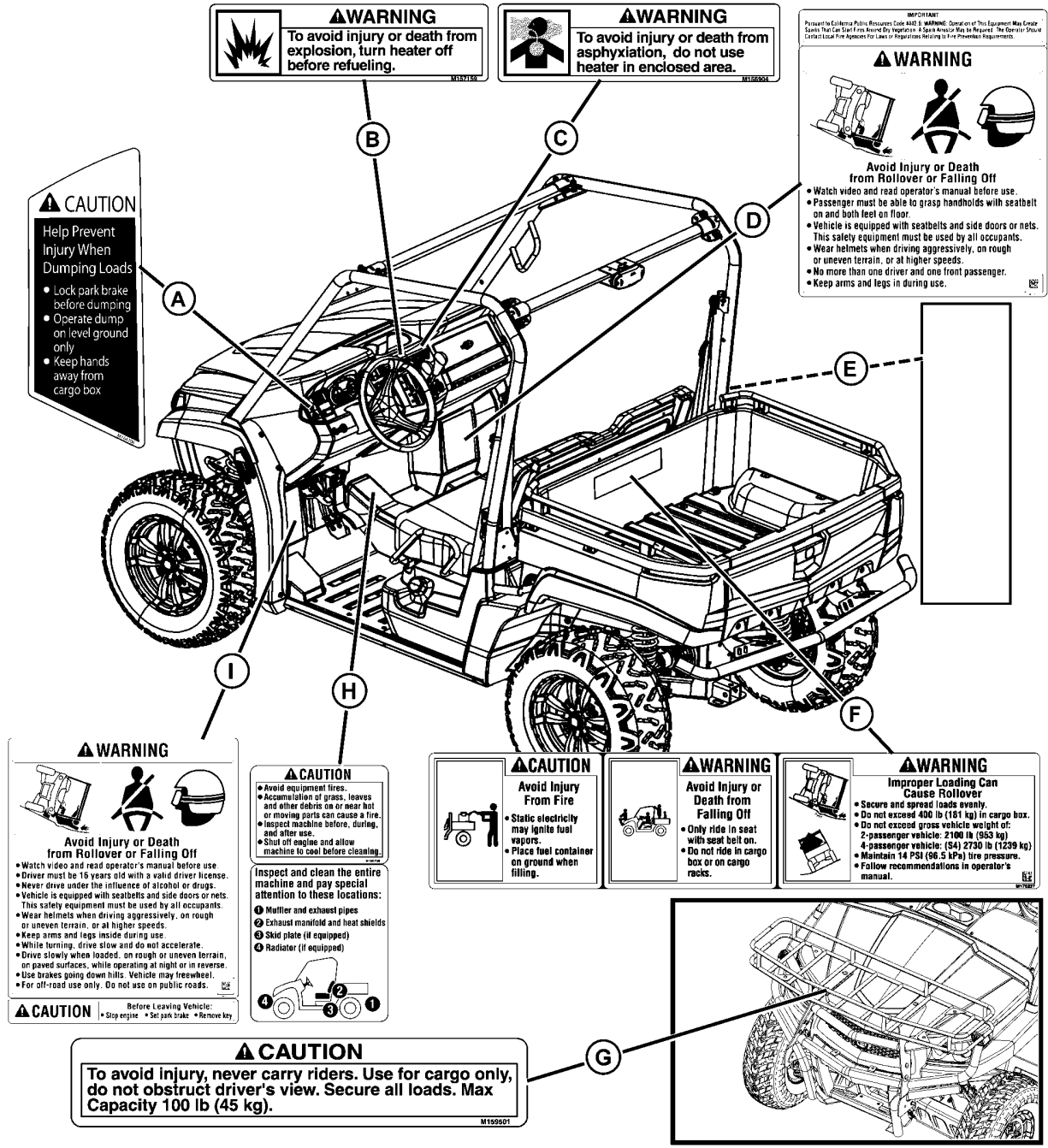

- A—CAUTION M164706 (Machines with Power Lift)
- B—WARNING M157159 (On Optional Heater)
- C—WARNING M156904 (On Optional Heater)
- D—WARNING M171712
- E—Protective Structure Safety and Certification M176766

- F—CAUTION/WARNING M176227
- G—CAUTION M159501 (On Optional Front Rack)
- H—CAUTION M165798
- I—WARNING M171711

MXT016235—UN—04NOV15

OUXM068,0000EAF-19-04NOV15

Safety Labels Text

Safety Label Location—XUV560 S4 (Bucket Seat)

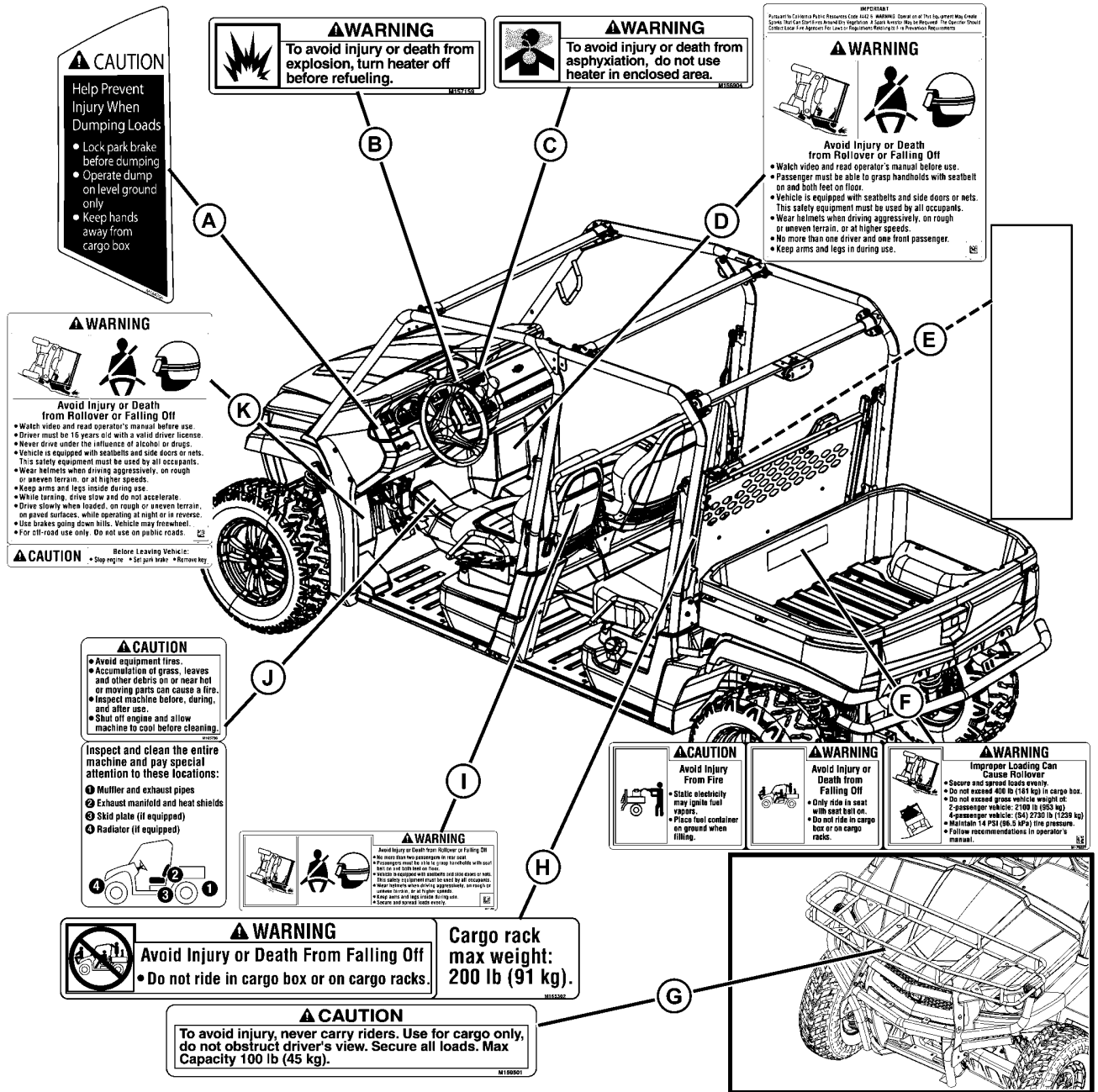

MXT016236—UN—04NOV15

- A—CAUTION M164706 (Machines with Power Lift)
- B—WARNING M157159 (On Optional Heater)
- C—WARNING M156904 (On Optional Heater)
- D—WARNING M171712
- E—Protective Structure Safety and Certification M176766
- F—CAUTION/WARNING M176227

- G—CAUTION M159501 (On Optional Front Rack)
- H—WARNING M165302
- I—WARNING M171200
- J—CAUTION M165798
- K—WARNING M171711

OUMX068.0000E5A-19-04NOV15

Safety Labels Text

Safety Label Location—XUV560 S4 (Bench Seat)

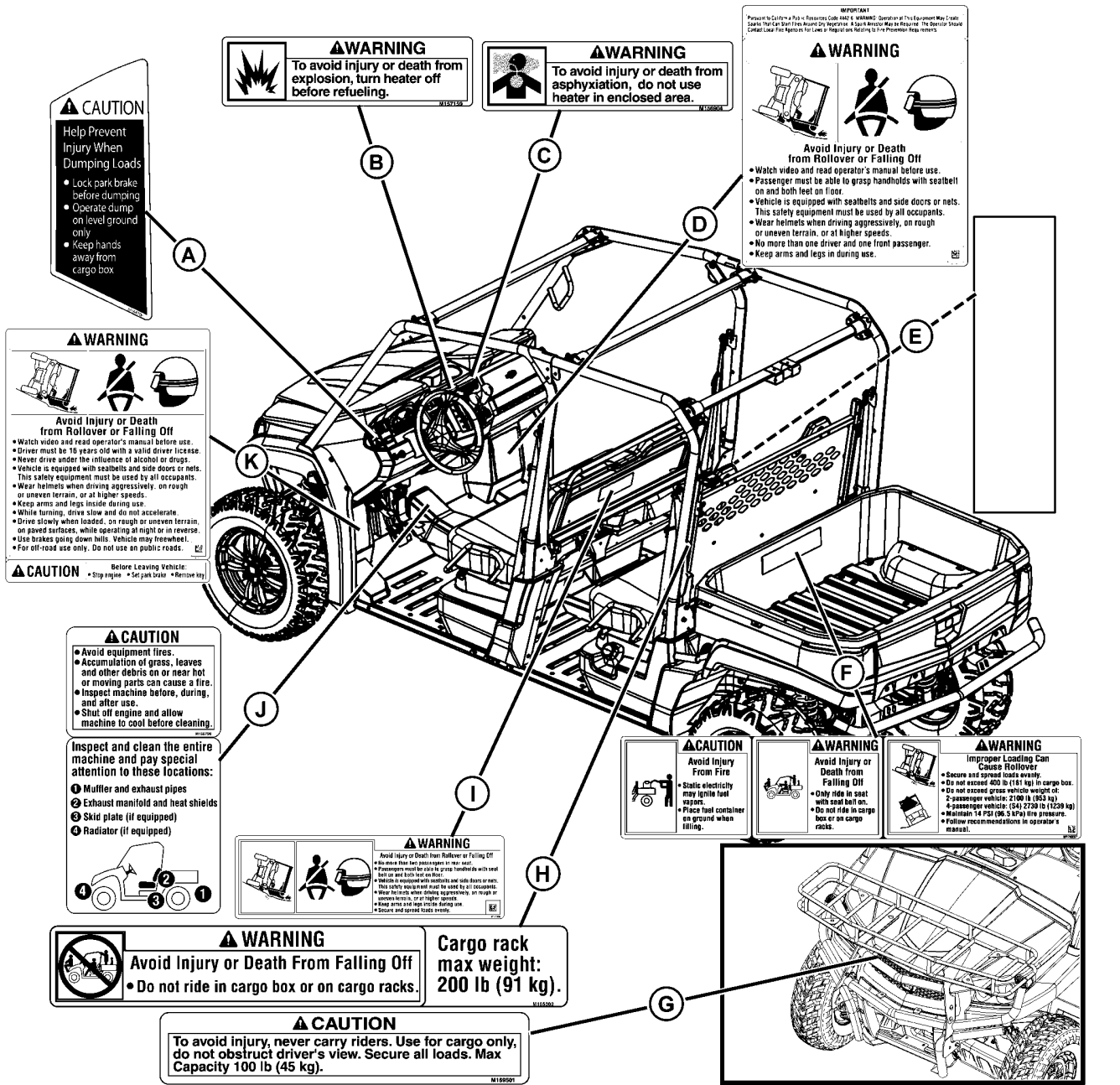

MXT016166—UN—04NOV15

A—CAUTION M164706 (Machines with Power Lift)

B—WARNING M157159 (On Optional Heater)

C—WARNING M156904 (On Optional Heater)

D—WARNING M171712

E—Protective Structure Safety and Certification M176766

F—CAUTION/WARNING M176227

G—CAUTION M159501 (On Optional Front Rack)

H—WARNING M165302

I—WARNING M171200

J—CAUTION M165798

K—WARNING M171711

OUMX068,0000E0-19-04NOV15

Safety Labels Text

Understanding the Machine Safety Labels



MXAL42363—UN—22MAY13

The machine safety labels shown in this section are placed in important areas on your machine to draw attention to potential safety hazards. DANGER or WARNING safety labels are located near specific hazards.

The operator's manual also explains any potential safety hazards whenever necessary in special safety messages that are identified with the word, CAUTION, and the safety-alert symbol.

On your machine safety labels, the words DANGER, WARNING, and CAUTION are used with this safety-alert symbol. DANGER identifies the most serious hazards:

- DANGER; The signal word DANGER indicates a hazardous situation which, if not avoided, will result in death or serious injury.
- WARNING; The signal word WARNING indicates a hazardous situation which, if not avoided, could result in death or serious injury.
- CAUTION; The signal word CAUTION indicates a hazardous situation which, if not avoided, could result in minor or moderate injury. CAUTION may also be used to alert against unsafe practices associated with events which could lead to personal injury.

Replace missing or damaged safety labels. Use this operator's manual for correct safety label placement.

There can be more safety information contained on parts and components sourced from suppliers that is not reproduced in this operator's manual.

French or Spanish Safety Labels and Operator's Manual

Operator's manuals and safety labels with content in French or Spanish are available for this machine through authorized John Deere dealers. See your John Deere dealer.

NOTE: Both text and no-text labels are shown. Your machine is only equipped with one of these types of labels.

MP47322,00F4601-19-26OCT16

CAUTION



MXAL47281—UN—16APR13

Help Prevent Injury When Dumping Loads

- Lock park brake before dumping
- Operate dump on level ground only
- Keep hands away from cargo box

OUO2005,0000159-19-22DEC14

WARNING

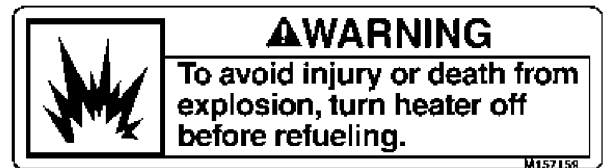

MXAL47282—UN—16APR13

To avoid injury or death from explosion, turn heater off before refueling.

OUO2005,000015A-19-29AUG13

Safety Labels Text

WARNING

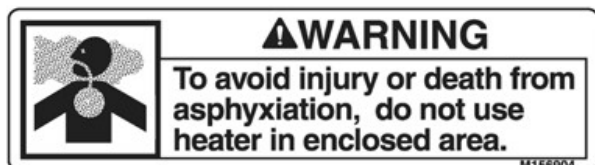

MXAL47283—UN—16APR13

To avoid injury or death from asphyxiation, do not use heater in enclosed area.

OUC2005.000015B-19-29AUG13

WARNING



MXT009143—UN—27SEP13

Important

Pursuant to California Public Resources Code 4442.6: WARNING: Operation of This Equipment May Create Sparks That Can Start Fires Around Dry Vegetation. A Spark Arrestor May be Required. The Operator Should Contact Local Fire Agencies For Laws or Regulations Relating to Fire Prevention Requirements.

Avoid Injury or Death from Rollover or Falling Off

- Watch video and read operator's manual before use.
- Passenger must be able to grasp handholds with seatbelt on and both feet on floor.
- Vehicle is equipped with seatbelts and side doors or

nets. This safety equipment must be used by all occupants.

- Wear helmets when driving aggressively, on rough or uneven terrain, or at higher speeds.
- No more than one driver and one front passenger.
- Keep arms and legs in during use.

OUC2005.000021B-19-27SEP13

Protective Structure Safety and Certification Label

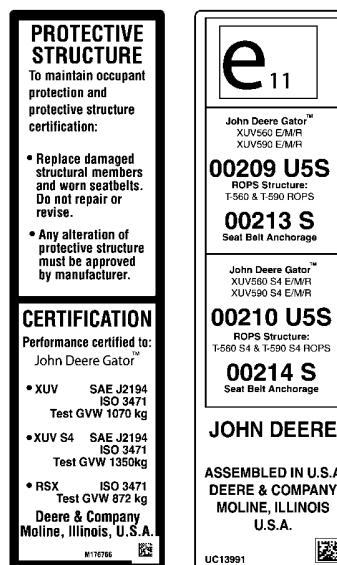

MXT020150—UN—17MAY17

One label is installed on your machine depending upon your region.

PROTECTIVE STRUCTURE

To maintain occupant protection and protective structure certification:

- Replace damaged structural members and worn seat belts. Do not repair or revise.
- Any alteration of protective structure must be approved by manufacturer.

CERTIFICATION

Performance certified to:
John Deere Gator™

- XUV
SAE J2194, ISO 3471, Test GVW 1070 kg
- XUV S4
SAE J2194, ISO 3471, Test GVW 1350 kg
- RSX
ISO 3471, Test GVW 872 kg

Safety Labels Text

PROTECTIVE STRUCTURE
Deere & Company Moline, Illinois,
U.S.A.

OUMX068,0001299-19-17MAY17

CAUTION—WARNING



MXT016173—UN—26OCT15

Avoid Injury From Fire

- Static electricity may ignite fuel vapors.
- Place fuel container on ground when filling.

Avoid Injury or Death from Falling Off

- Only ride in seat with seat belt on.
- Do not ride in cargo box or on cargo racks.

Improper Loading Can Cause Rollover

- Secure and spread loads evenly.
- Do not exceed 400 lb (181 kg) in cargo box.
- Do not exceed gross vehicle weight of:
2-passenger vehicle 2100 lb (953 kg)
4-passenger vehicle (S4) 2730 lb (1239 kg)
- Maintain 14 PSI (96.5 kPa) tire pressure.
- Follow recommendations in operator's manual.

OUMX068,0000E6F-19-26OCT15

CAUTION

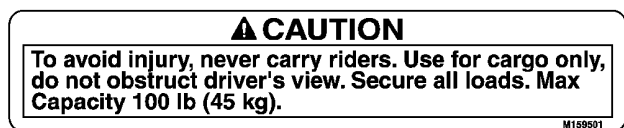

MXT012789—UN—19JAN15

Avoid Injury

To avoid injury, never carry riders. Use for cargo only, do not obstruct driver's view. Secure all loads. Max Capacity 100 lb. (45 kg).

OUMX068,0000B06-19-19JAN15

WARNING

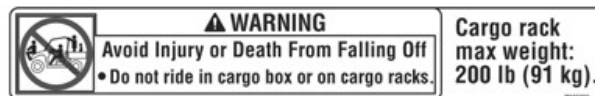

MXL44646—UN—28MAR13

Avoid Injury or Death From Falling Off

- Do not ride in cargo box or on cargo racks.
- Cargo rack max weight: 200 lb. (91 kg).

OUC2005,0000194-19-19JAN15

WARNING

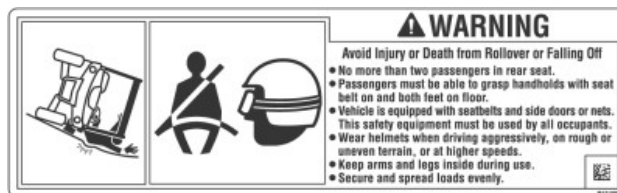

MXT016174—UN—26OCT15

Avoid Injury or Death from Rollover or Falling Off

- No more than two passengers in rear seat.
- Passengers must be able to grasp handholds with seat belt on and both feet on floor.
- Vehicle is equipped with seatbelts and side doors or nets. This safety equipment must be used by all occupants.
- Wear helmets when driving aggressively, on rough or uneven terrain, or at higher speeds.
- Keep arms and legs inside during use.
- Secure and spread loads evenly.

OUMX068,0000E70-19-26OCT15

Safety Labels Text

CAUTION

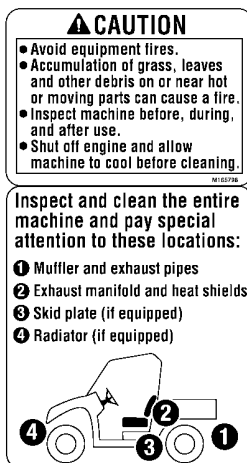

MXAL47291—UN—16APR13

- Avoid equipment fires.
- Accumulation of grass, leaves and other debris on or near hot or moving parts can cause a fire.
- Inspect machine before, during, and after use.
- Shut off engine and allow machine to cool before cleaning.

Inspect and clean the entire machine and pay special attention to these locations:

1. Muffler and exhaust pipes
2. Exhaust manifold and heat shields
3. Skid plate (if equipped)
4. Radiator (if equipped)

OUO2005,000015F-19-29AUG13

WARNING



MXT009142—UN—27SEP13

Avoid Injury or Death from Rollover or Falling Off

- Watch video and read operator's manual before use.
- Driver must be 16 years old with a valid driver license.
- Never drive under the influence of alcohol or drugs.
- Vehicle is equipped with seatbelts and side doors or nets. This safety equipment must be used by all occupants.
- Wear helmets when driving aggressively, on rough or uneven terrain, or at higher speeds.
- Keep arms and legs in during use.
- While turning, drive slow and do not accelerate.
- Drive slowly when loaded, on rough or uneven terrain, on paved surfaces, while operating at night or in reverse.
- Use brakes going down hills. Vehicle may freewheel.
- For off-road use only. Do not use on public roads.

CAUTION

Before Leaving Vehicle:

- Stop engine
- Set park brake
- Remove key

OUO2005,000021C-19-13SEP16

Safety Labels No-Text

Safety Label Location—XUV560 (Bucket Seat)

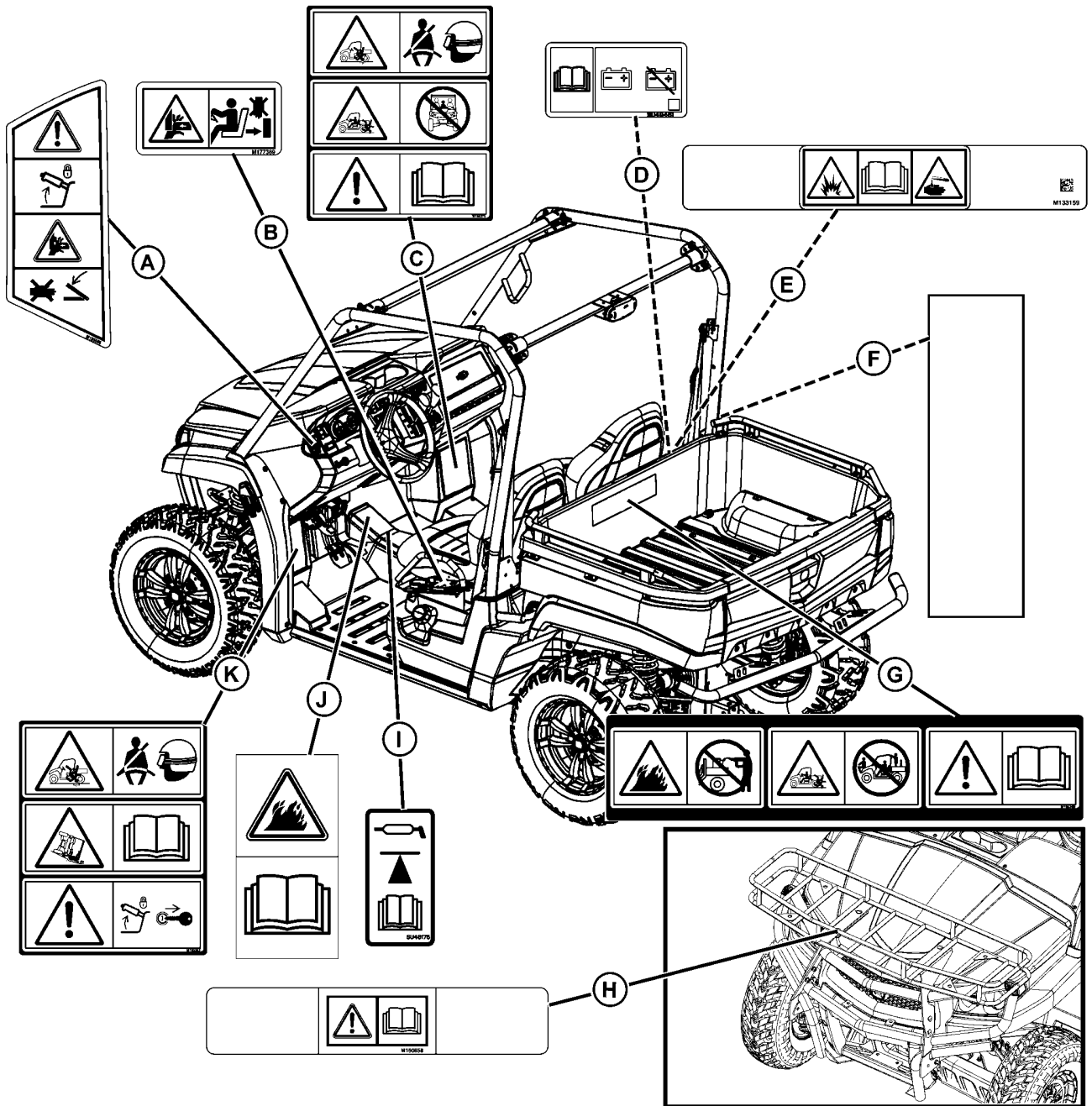

MXT020143—UN—18MAY17

- A—Help Prevent Injury when Dumping Loads M165565 (Machines with Power Lift)
- B—Avoid Injury from Crushing M177389
- C—Avoid Injury or Death from Rollover or Falling Off M165375
- D—Read Operators Manual, Service Battery SU49461
- E—Avoid Injury From Battery Gases and Acid M133159

- F—Protective Structure Safety and Certification UC13991
- G—Avoid Injury from Fire M165368
- H—Avoid Injury M160658 (On Optional Front Rack)
- I—Read Operators Manual, Jacking Point SU48175
- J—Avoid Injury From Equipment Fires M165273
- K—Avoid Injury or Death from Rollover or Falling Off M165362

OUMX068.0001292-19-18MAY17

Safety Labels No-Text

Safety Label Location—XUV560 (Bench Seat)

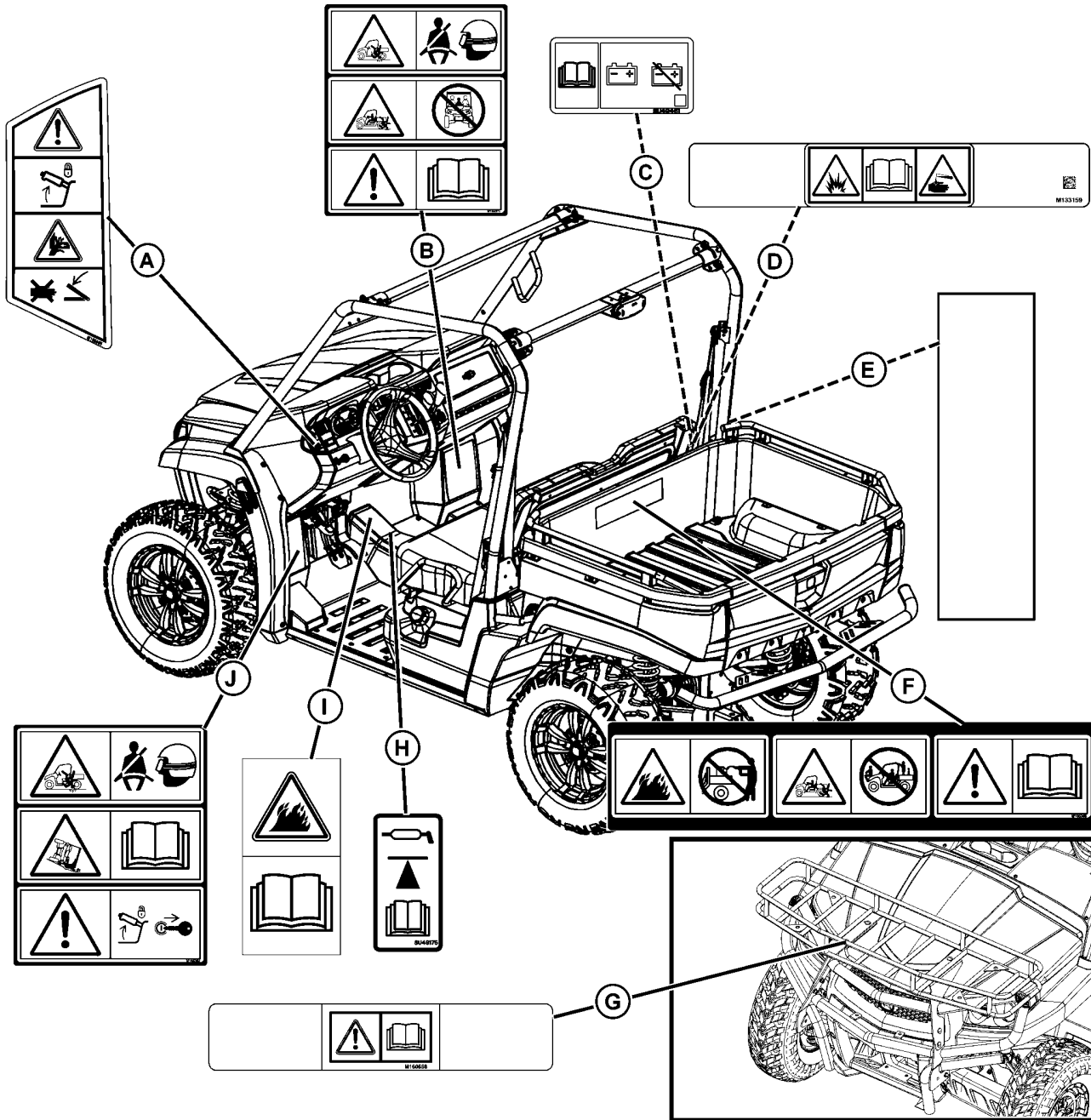

MXT020144—UN—19MAY17

- A—Help Prevent Injury when Dumping Loads M165565 (Machines with Power Lift)
- B—Avoid Injury or Death from Rollover or Falling Off M165375
- C—Read Operators Manual, Service Battery SU49461
- D—Avoid Injury From Battery Gases and Acid M133159
- E—Protective Structure Safety and Certification UC13991

- F—Avoid Injury from Fire M165368
- G—Avoid Injury M160658 (On Optional Front Rack)
- H—Read Operators Manual, Jacking Point SU48175
- I—Avoid Injury From Equipment Fires M165273
- J—Avoid Injury or Death from Rollover or Falling Off M165362

OUMX068,0001293-19-12MAY17

Safety Labels No-Text

Safety Label Location—XUV560 S4 (Bucket Seat)

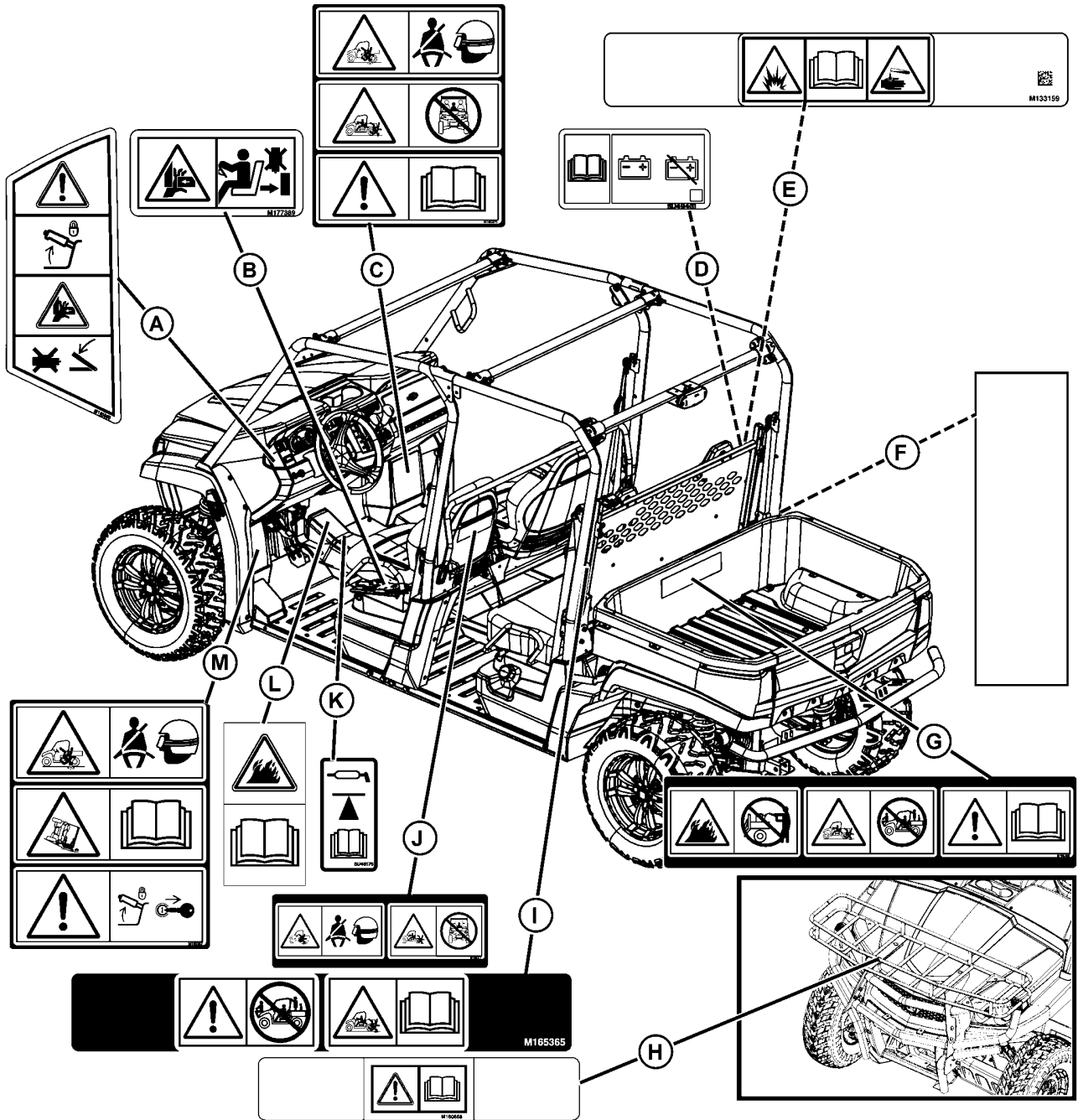

MXT020145—UN—19MAY17

- A—Help Prevent Injury when Dumping Loads M165565 (Machines with Power Lift)
- B—Avoid Injury from Crushing M177389
- C—Avoid Injury or Death from Rollover or Falling Off M165375
- D—Read Operators Manual, Service Battery SU49461
- E—Avoid Injury From Battery Gases and Acid M133159
- F—Protective Structure Safety and Certification UC13991

- G—Avoid Injury from Fire M165368
- H—Avoid Injury M160658 (On Optional Front Rack)
- I—Avoid Injury or Death from Falling Off M165365
- J—Avoid Injury or Death from Rollover or Falling Off M168539
- K—Read Operators Manual, Jacking Point SU48175
- L—Avoid Injury From Equipment Fires M165273
- M—Avoid Injury or Death from Rollover or Falling Off M165362

OUMX068,0001294-19-16MAY17

Safety Labels No-Text

Safety Label Location—XUV560 S4 (Bench Seat)

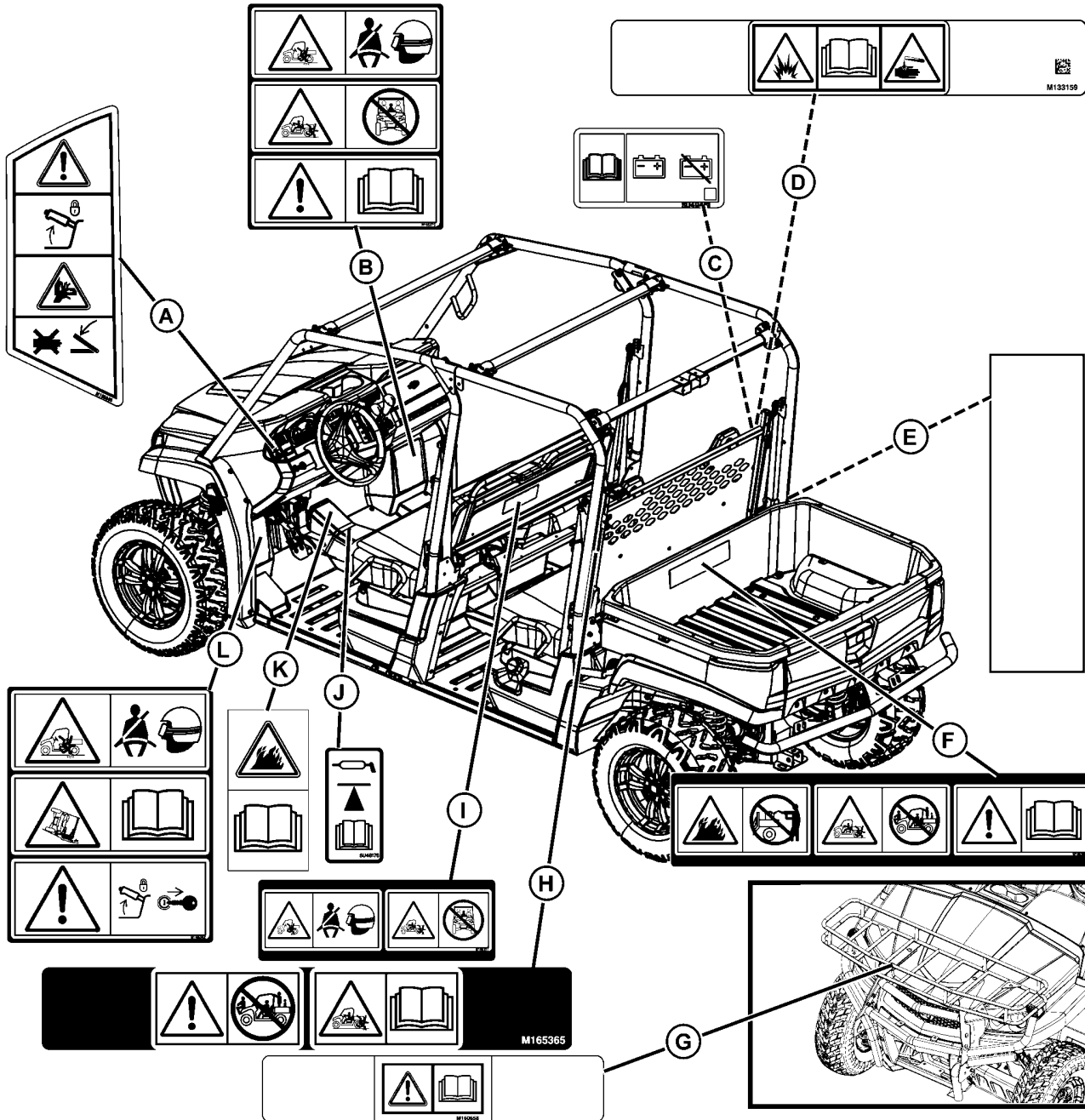

MXT020146—UN—19MAY17

- A—Help Prevent Injury when Dumping Loads M165565 (Machines with Power Lift)
- B—Avoid Injury or Death from Rollover or Falling Off M165375
- C—Read Operators Manual, Service Battery SU49461
- D—Avoid Injury From Battery Gases and Acid M133159
- E—Protective Structure Safety and Certification UC13991
- F—Avoid Injury from Fire M165368

- G—Avoid Injury M160658 (On Optional Front Rack)
- H—Avoid Injury or Death from Falling Off M165365
- I—Avoid Injury or Death from Rollover or Falling Off M168539
- J—Read Operators Manual, Jacking Point SU48175
- K—Avoid Injury From Equipment Fires M165273
- L—Avoid Injury or Death from Rollover or Falling Off M165362

OUMX068.0001295-19-16MAY17

Safety Labels No-Text

Understanding the No-Text Machine Safety Labels



TCT005498—UN—11SEP12

At several important places on this machine, safety signs are affixed which signify potential danger. The hazard is identified by a pictorial in a warning triangle. An adjacent pictorial provides information on how to avoid personal injury. These safety signs, their placement on the machine, and a brief explanatory text are shown in this Safety section.

There can be additional safety information contained on parts and components sourced from suppliers that is not reproduced in this operator's manual.

MX00654,0000389-19-05JUN17

Avoid Injury from Crushing

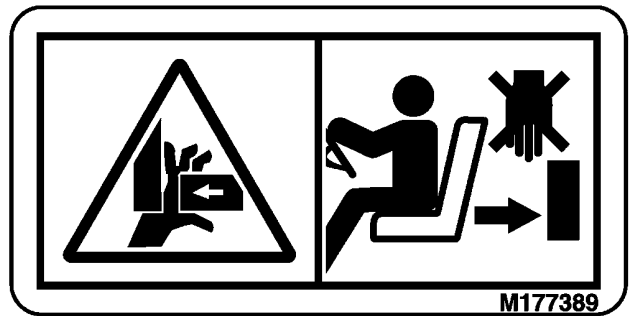

MXT016182—UN—30OCT15

- Avoid crushing injury.
- Keep hands away from crushing area while parts are moving.

OUMX068,0000EA1-19-30OCT15

Help Prevent Injury When Dumping Loads



MXT007994—UN—29AUG13

Help Prevent Injury When Dumping Loads

- Lock park brake before dumping
- Operate dump on level ground only
- Keep hands away from cargo box

OUC0205,0000160-19-22DEC14

Avoid Injury or Death from Rollover or Falling Off



MXT010005—UN—13MAY14

Avoid Injury or Death from Rollover or Falling Off

- Watch video and read operator's manual before use.
- Passenger must be able to grasp handholds with seatbelt on and both feet on floor.
- Vehicle is equipped with seatbelts and side doors or nets. This safety equipment must be used by all occupants.
- Wear helmets when driving aggressively, on rough or uneven terrain, or at higher speeds.
- No more than one driver and one front passenger.
- Keep arms and legs in during use.

OUMX068,0000789-19-13MAY14

Safety Labels No-Text

Read Operator's Manual, Service Battery

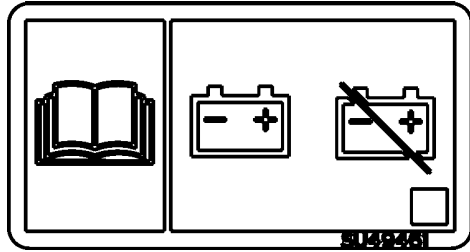

MXT020147—UN—16MAY17

- Read Operator's Manual
- Service Battery

OUMX068,0001296-19-16MAY17

Protective Structure Safety and Certification Label

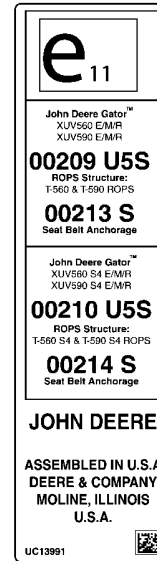

MXT020150—UN—17MAY17

One label is installed on your machine depending upon your region.

Avoid Injury From Battery Gases and Acid



MXT020148—UN—16MAY17

- Shield eyes, explosive gases can cause blindness or injury.
- No sparks, flames, smoking.
- Sulfuric acid can cause blindness or severe burns.
- Keep out of the reach of children.
- Do not tip.
- Keep vent caps tight and level.
- Flush eyes immediately with water. Get medical help fast.

OUMX068,0001297-19-16MAY17

PROTECTIVE STRUCTURE

To maintain occupant protection and protective structure certification:

- Replace damaged structural members and worn seat belts. Do not repair or revise.
- Any alteration of protective structure must be approved by manufacturer.

CERTIFICATION

Performance certified to:
John Deere Gator™

- XUV
SAE J2194, ISO 3471, Test GVW 1070 kg
- XUV S4
SAE J2194, ISO 3471, Test GVW 1350 kg
- RSX
ISO 3471, Test GVW 872 kg
Deere & Company Moline, Illinois, U.S.A.

OUMX068,0001299-19-17MAY17

Avoid Injury from Fire



MXT007996—UN—29AUG13

Safety Labels No-Text

Avoid Injury From Fire

- Static electricity may ignite fuel vapors.
- Place fuel container on ground when filling.

Avoid Injury or Death from Falling Off

- Only ride in seat with seat belt on.
- Do not ride in cargo box or on cargo racks.

Improper Loading Can Cause Rollover

- Secure and spread loads evenly.
- Do not exceed 400 lb (181 kg) in cargo box.
- Do not exceed gross vehicle weight of:
2-passenger vehicle 2100 lb (953 kg)
4-passenger vehicle (S4) 2730 lb (1239 kg)
- Maintain 14 PSI (96.5 kPa) tire pressure.
- Follow recommendations in operator's manual.

OUMX068,0000E71-19-26OCT15

Avoid Injury or Death from Rollover or Falling Off



MXT008885—UN—06SEP13

Avoid Injury or Death from Rollover or Falling Off

- No more than two passengers in rear seat.
- Passengers must be able to grasp handholds with seat belt on and both feet on floor.
- Vehicle is equipped with seatbelts and side doors or nets. This safety equipment must be used by all occupants.
- Wear helmets when driving aggressively, on rough or uneven terrain, or at higher speeds.
- Keep arms and legs inside during use.
- Secure and spread loads evenly.

OUMX068,0000E72-19-26OCT15

Avoid Injury



MXT007998—UN—29AUG13

Avoid Injury

To avoid injury, never carry riders. Use for cargo only, do not obstruct driver's view. Secure all loads. Max Capacity 100 lb. (45 kg).

OOU2005,0000164-19-19JAN15

Avoid Injury or Death from Falling Off



M165365
MXT008884—UN—06SEP13

Avoid Injury or Death from Falling Off

Do not ride in cargo box or on cargo racks.
Cargo rack max weight: 200 lb (91 kg).

OOU2005,0000196-19-06SEP13

Read Operators Manual, Jacking Point

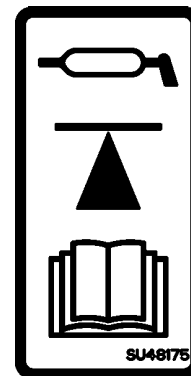

MXT020149—UN—16MAY17

- Read Operators Manual
- Jacking Point

OUMX068,0001298-19-16MAY17

Safety Labels No-Text

Avoid Injury From Equipment Fires

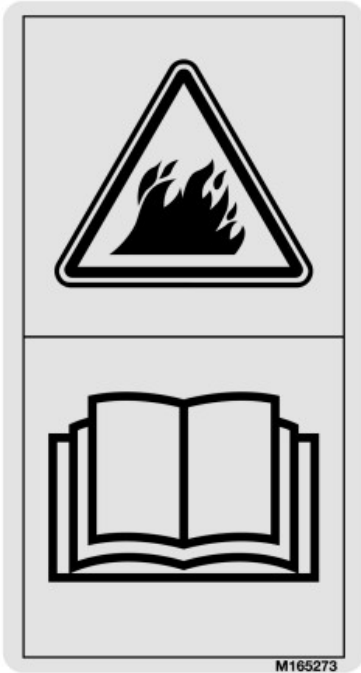

M165273
MXT010007—UN—13MAY14

- Avoid equipment fires.
- Accumulation of grass, leaves and debris on or near hot or moving parts can cause a fire.
- Inspect and clean the entire machine before, during and after use.
- Shut off engine and allow machine to cool before cleaning.
- Carefully read Operator's Manual Machine Clean out section for details.

OUMX068,000027-19-08JUL16

Avoid Injury or Death from Rollover or Falling Off

- Watch video and read operator's manual before use.
- Driver must be 16 years old with a valid driver license.
- Never drive under the influence of alcohol or drugs.
- Vehicle is equipped with seat belts and side doors or nets. This safety equipment must be used by all occupants.
- Wear helmets when driving aggressively, on rough or uneven terrain, or at higher speeds.
- Keep arms and legs in during use.
- While turning, drive slow and do not accelerate.
- Drive slowly when loaded, on rough or uneven terrain, on paved surfaces, while operating at night or in reverse.
- Use brakes going down hills. Vehicle may freewheel.
- For off-road use only. Do not use on public roads.

Before Leaving Vehicle:

- Stop engine
- Set park brake
- Remove key

OUMX068,0000788-19-22DEC14

Avoid Injury or Death from Rollover or Falling Off



M165273
MXT010008—UN—13MAY14

Safety

Supervisor Safety Responsibilities

- Make sure all operators of this machine are thoroughly trained and are familiar with the operator's manual and understand the machine warning labels.
- Be sure to establish any special safety procedures for existing work conditions and train operators in those procedures.
- Supervisors, operators and mechanics should be familiar with and practice the safety standards that apply to this machine.

RH75544,0000159-19-08APR13

Operator Training Required

- Read the operator's manual and other training material. If the operator or mechanic cannot read English, it is the owner's responsibility to explain this material to them. This publication is available in other languages.
- Become familiar with the safe operation of the equipment, operator controls, and safety signs.
- All operators and mechanics should be trained. The owner of the machine is responsible for training the users.
- Never let children or untrained people operate or service the equipment. Local regulations may restrict the age of the operator.
- The owner/user can prevent and is responsible for accidents or injuries occurring to themselves, other people, or property.
- Operate the machine in an open, unobstructed area under the direction of an experienced operator when training.

RH75544,000015A-19-30APR13

Operating Safely

- Read, understand and follow all instructions in the operator's manual, on the machine and on the safety video before starting.
- Misuse can lead to accidents, severe bodily injury or death.
- The utility vehicle's tires are designed for off-road use only. Paved surfaces may seriously affect handling and control of the vehicle. If you must operate on a paved surface, travel slowly and do not make sudden turns or stops.
- Do not operate this vehicle on a frozen body of water. The vehicle could break through the ice, causing injury or even death.
- Go slowly and be extra careful when riding on snow-covered or ice-covered terrain.
- Slow down and be careful of traffic when operating near or crossing roadways. Use care when

approaching blind corners, shrubs, trees, or other objects that may obscure vision.

- The operator should always make sure that the passenger is aware of correct safety procedures while riding in the utility vehicle.
- Use the correct flags, lights, signs and reflectors on the vehicle to warn other drivers when operating near roadways. Make sure these features are clean and visible for 152 m (500 ft.).
- The passenger should always use the hand holds.
- On machines with seat belts, to avoid serious injury, always ensure that occupants have safely secured their seat belts prior to starting this vehicle.
- Horseplay can lead to accidents, severe bodily injury or death. Do not attempt stunts, jumps, or quick acceleration to raise front wheels off the ground. These actions can result in accidents or vehicle overturns.
- Sit on the center of the seat and keep both feet within the foot platform perimeter. Clean foot platform if dirty, and remove any debris from around foot controls.
- Check for debris in engine compartment, especially around exhaust system components.
- Always use both hands for steering.
- Know location of controls and how and what they operate.
- Never operate utility vehicle while standing.
- Never operate utility vehicle with the cargo box raised.
- Check brake action before beginning vehicle operation. Adjust or service the brakes as necessary.
- Do not allow the Gross Vehicle Weight (GVW) to exceed the Gross Vehicle Weight Rating (GVWR) of the vehicle.
- Before shifting into reverse, always check for obstacles or people behind the machine.
- Always back slowly.
- Inspect vehicle before operating. Be sure hardware is tight. Repair or replace damaged, badly worn, or missing parts. Be sure guards and shields are in good condition and fastened in place. Make any necessary adjustments before operating.
- Do not leave vehicle unattended when it is running.
- Operate during daylight or with good artificial light and if you drive at night, use the lights.
- Do not operate vehicle if under the influence of alcohol or other drugs.
- Avoid sudden starts, stops, or turns.
- Always use a level turn-around area.
- Do not wear radio or music headphones. Safe service and operation require your full attention.

OUMX068,00009BC-19-10SEP14

Safety

Using a Spark Arrestor

The California Public Resources Code, section 4442.5 provides as follows:

No person shall sell, offer for sale, lease, or rent to any person any internal combustion engine subject to Section 4442 or 4443, and not subject to Section 13005 of the Health and Safety Code, unless the person provides a written notice to the purchaser or bailee, at the time of sale or at the time of entering into the lease or rental contract, stating that it is a violation of Section 4442 or 4443 to use or operate the engine on any forest-covered, brush-covered, or grass-covered land unless the engine is equipped with a spark arrestor, as defined in Section 4442, maintained in effective working order or the engine is constructed, equipped, and maintained for the prevention of fire pursuant to Section 4443. Cal. Pub. Res. Code 4442.5.

Other states or jurisdictions may have similar laws. A spark arrestor for your machine may be available from your authorized dealer. An installed spark arrestor must be maintained in good working order by the operator.

MP47322,00F4616-19-08JUL13

Parking Safely

1. Stop vehicle on a level surface, not on a slope.
2. Fully lower the cargo box and any attachments on the machine that can be lowered.
3. Lock park brake.
4. Stop engine.
5. Remove key.
6. Before you leave the operator's seat, wait for engine and all moving parts to stop.
7. Disconnect the negative battery cable or remove the spark plug wires (for gasoline engines) before servicing the machine.

OUMX068,00005F5-19-11JUL13

Protect Children/Small Adults and Prevent Accidents

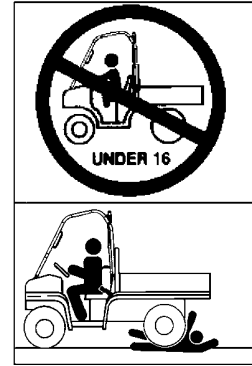

MXAL43278—UN—15MAR13

- This utility vehicle should not be operated by anyone under the age of 16 years.
- This utility vehicle should not be operated by anyone without a valid driver license.
- Young drivers may not be physically able to control the machine or may not be mature enough to make safe driving decisions.
- Do not allow children to ride as a passenger in this vehicle. Children may not be able to sit safely in the passenger seat and use handholds properly. Passengers must be able to grasp handholds with their back against the seat, seat belt on, and both feet on the floor.
- Passenger should always use the handholds while the vehicle is moving.
- Seat belts installed on utility vehicles are not designed to restrain children.
- Never carry passengers, especially children, in the cargo box area. Do not tow children in a cart or trailer.
- Never assume that children remain where you last saw them. Stay alert to the presence of children.
- Before backing or turning, look behind and around the utility vehicle for children.
- Be alert at all times, drive forward and in reverse carefully. People, especially children, can move quickly into an area of operation.
- Use extra care when coming to blind corners, shrubs, trees, or other objects that may block vision.
- Misuse and recreational riding can lead to accidents, severe bodily injury, or death.

OQO2005,0000169-19-28FEB17

Avoid Excessive Speeds

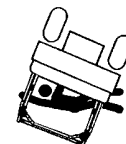

MXAL43279—UN—15MAR13

- Always wear a helmet when traveling at high speeds.

Safety

- Always travel at a speed that is safe and proper for the terrain, visibility and operating conditions, and your experience operating the machine.
- Use caution when operating the machine in reverse. Use a slow speed and do not make sharp turns. Always look behind before backing.
- Never travel at excessive speeds on slopes, either going up or down. Use a slow speed and do not make sharp turns. Become experienced driving the machine on small slopes before driving on larger hills.

MX00654,00000B4-19-30AUG13

Avoid Tipping

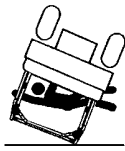

MXAL43279—UN—15MAR13

Accidents resulting in serious injury or death can occur from tipping the utility vehicle. Observe the following practices to help prevent accidents and always wear a helmet when operating this vehicle in an aggressive manner or on uneven or rough terrain.

- Drive very slowly when turning. Sharp turns could cause the utility vehicle to tip over.
- Reduce speed and exercise extreme caution on slopes or on rough ground.
- Do not overload vehicle and avoid shifting loads. Reduce load when operating over rough or hilly terrain.
- Do not stop or start suddenly when going uphill or downhill. Be especially cautious when changing direction on slopes.
- Stay alert for holes, rocks, and other hidden hazards in the terrain.
- Keep away from drop-offs, ditches, embankments, as well as ponds and other bodies of water. The machine could suddenly roll over if a wheel goes over the edge of a cliff or ditch or if the edge caves in.
- Keep front wheels straight at crest of hill or going over bumps.
- When descending a hill, remove foot from accelerator pedal and apply brakes to reduce speed and maintain control.
- Do not make unauthorized changes or modifications to the utility vehicle.
- This list of potential overturning hazards is not exhaustive.

MX00654,00000B5-19-09APR15

Use Seat Belts, Nets and Doors Properly



MXT008507—UN—10JAN17

- Use a seat belt and doors or nets, if equipped, to minimize chance of injury from an accident, such as an overturn.
- Do not operate machine with any portion of the operator safety system inoperative or removed.
- Inspect seat belts, nets and doors for proper operation before each machine use.
- Insert metal tab of net, if equipped, into buckle until it clicks, indicating it is latched. Pull back on net to confirm it is securely latched.
- Layers of heavy clothing can interfere with proper positioning of the seat belt and can reduce the effectiveness of the seat belt.
- Never modify, disassemble, or attempt to repair a seat belt, nets or doors.
- Inspect seat belts, nets and doors, if equipped, at least once a year. Look for signs of loose hardware or material damage, such as cuts, fraying, extreme or unusual wear, or abrasion. Replace only with John Deere approved replacement parts.
- Replace entire seat belt if mounting hardware, buckle, belt, or retractor show signs of damage.

OUMX068,00002E3-19-28FEB17

Keep Protective Structure Installed Properly

- Never operate the machine without the Protective Structure installed.
- If the Protective Structure is loosened or removed for any reason, make certain all parts of the Protective Structure are installed correctly. All Protective Structure hardware must be tightened to the proper torque per manufacturer recommendations.
- Any alteration of the Protective Structure must be approved by the manufacturer. The protection provided by the Protective Structure can be impaired if the Protective Structure is subjected to structural damage, is involved in an overturn incident, or is in any way altered by welding, bending, drilling, or cutting.
- Never attempt to repair a damaged or altered Protective Structure. It must be replaced to maintain the manufacturer certification of the structure.

MX00654,00000B6-19-06NOV15

Safety

Keep Riders Off Vehicle



MXAL43281—UN—15MAR13

- Seating is provided for operator and one front seat passenger. Seating may also be provided for two rear seat passengers on some models. All passengers must be able to grasp handholds with seat belt on and both feet on the floor.
- Never allow riders in the cargo box or other areas where seats are not provided.
- Riders on vehicle are subject to injury such as being struck by foreign objects or being thrown off of the vehicle and severely injured or killed.
- Riders affect the operator's ability to control the vehicle as well as its center of gravity. Also, riders could obstruct the operator's view resulting in the vehicle being operated in an unsafe manner.

OUMX068,0000BC5-19-08MAY15

Before Driving

1. Perform Daily Operating Checklist in OPERATING.
2. Clean foot platform if dirty, and remove any debris from around foot controls. Sit on the center of seat and keep both feet inside foot platform perimeter.
3. Inspect utility vehicle for signs of wear or damage.
4. All safety equipment must be in good condition and fastened in place:
 - Lights.
 - Shields.
 - Safety start devices.
5. Before moving, check around utility vehicle, be sure no one is near it.
6. Inspect mechanical condition of your vehicle before each use to minimize chance of injury or being stranded. Remember, you can ride farther in an hour than you can walk in a day.

Be sure to check condition of tires and wheels, wheel hardware torque, and maintain proper tire pressure.

7. Securely anchor all loads.

OUMX068,0000BC6-19-08MAY15

Transport Loads Safely

- Be sure load is evenly distributed in cargo box.
- Do not load above height of cargo box.
- Securely anchor all loads in cargo box.

- Reduce cargo box load when operating on rough or hilly terrain.

RH75544,0000165-19-08APR13

Using Front Attachments

Remove front attachments such as drawbar hitches, hitch mounted winches, or blades when operating on rough or uneven terrain. Front attachments may contact the ground when operating on rough or uneven terrain which may cause loss of control or rollover.

OUMX068,0000634-19-22SEP16

Towing Loads Safely With Utility Vehicle

- To provide adequate braking ability and traction, weight of towed load (trailer plus cargo) must never exceed the vehicle payload (operator plus passenger plus cargo box load).
- Do not tow a load that exceeds the maximum allowable towing load for this vehicle, as specified in this operator's manual.
- Stopping distance increases with speed and weight of towed load. Travel slowly and allow extra time and distance to stop.
- Tow load at a speed slow enough to maintain control.
- Excessive towed load can cause loss of traction and loss of control on slopes. Reduce towed weight when operating on slopes.
- Never allow children or others in or on towed equipment.
- Use only approved hitches. Tow only with a machine that has a hitch designed for towing. Do not attach towed equipment except at the approved hitch point.
- Follow the manufacturer's recommendations for weight limits for towed equipment and towing on slopes.
- If you cannot back up a slope with a towed load, the slope is too steep to operate on with the towed load. Reduce the towed load or do not operate.
- Do not turn sharply. Use additional caution when turning or operating under adverse surface conditions. Use care when reversing.
- Do not shift to neutral and coast downhill.
- Secure towed loads before transporting.

OUMX068,000091B-19-09SEP14

Safety

Driving On Rough Terrain



MXAL43282—UN—15MAR13

- Always wear a helmet when operating the vehicle on uneven or rough terrain.
- Use existing trails. Avoid terrain such as dangerous slopes and impassable swamps. Watch carefully for bumps, holes, ruts, loose terrain, or other obstacles.
- Look ahead at terrain. Know what is coming and be prepared to react. Be alert for hazards.
- Keep front wheels straight at crest of hill or going over bumps.
- Reduce speed according to trail, terrain, and visibility conditions.
- The passenger should always use the hand holds.

BB87125,0000D46-19-19APR13

Climbing or Descending a Hill or Slope

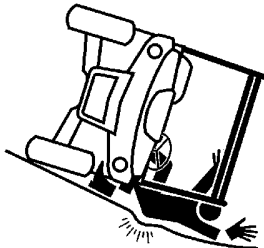

MXT008509—UN—10JAN17

- Always use the brakes when going down slopes. The utility vehicle can speed up (freewheel) going down a slope. Engine or clutch braking effect is minimal.
- Balance loads evenly and secure them. Braking could shift the load and affect vehicle stability.
- Sit on center of seat and keep both feet within foot platform.
- Never drive past the limit of visibility. Slow down near crest of hill until getting a clear view of the other side. Never go over the top of any hill at a high speed. An obstacle, sharp drop, another vehicle or person, could be on the other side of the hill.
- Keep front wheels straight at crest of hill or going over bumps.
- Do not stop or start suddenly when going uphill or downhill. Be especially cautious when changing direction on slopes.
- If vehicle stops or loses power going up a hill, lock park brake to hold vehicle on slope. Maintain direction of travel and release brake slowly. Back straight down hill slowly while maintaining control. Do not turn vehicle sideways. Vehicle is more stable in a straight forward or rearward position.

- Always descend hill or slope at slow speeds and in a controlled manner. When descending a hill, remove foot from accelerator pedal and apply brakes to reduce speed and maintain control.
- The vehicle has a limited amount of engine braking that can assist when going down a hill or slope, but it is highly recommended to remove foot from throttle pedal and to use service brakes during descent as well.
- If the vehicle is freewheeling (engine braking is not engaged), use the service brakes to slow vehicle travel. Do not reengage engine braking (do not depress the throttle pedal) when freewheeling as that may cause the vehicle to skid.

RH75544,0000169-19-28FEB17

Driving Across Slopes

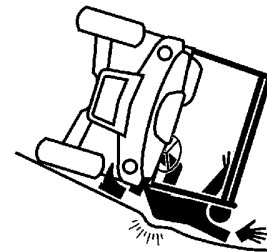

MXT008509—UN—10JAN17

- Reduce speed and use caution on slopes and in sharp turns.
- Stay alert for holes, rocks and other hidden hazards in the terrain.
- When riding on soft terrain, turn front wheels slightly uphill to keep utility vehicle on a straight line across the hill.
- If utility vehicle begins to tip, turn front wheel downhill to gain control before proceeding.

BB87125,0000D48-19-28FEB17

Riding Through Water

- Driving through water can contaminate the power train and electrical systems resulting in long-term vehicle damage.
- Your vehicle is capable of driving through still water in depth equal to the floorboard height.
- Never drive through deep or fast flowing water. The vehicle may become unstable and difficult to control.
- Never cross any body of water where depth may be unknown to the operator.
- If you must ride through water:
 - Cross at a designated route if possible. Choose a course within the waterway where both banks have a gradual incline. Cross at a point known to be safe.

Safety

- Proceed at a slow steady speed to avoid submerged obstacles and slippery rocks.
- Avoid water crossings where the operation of a utility vehicle may cause damage to waterway beds or erode waterway shoreline.
- Stopping ability of vehicles with external brakes may be affected after driving through water. If necessary, apply brakes several times to dry them out.
- If water levels exceed the floorboard height at any time, contact your dealer to have the engine, transmission, differential fluids, and fuel tank checked for contamination.
- If the engine stops during water crossing, do not restart the engine. Major engine damage can result if the machine is not thoroughly inspected. Take the vehicle to your dealer before starting the engine.
- If you must continue to operate the vehicle prior to dealer inspection, perform the following inspection and service:
 - a. Move the vehicle to dry land, or at the very least to water below the floorboard.
 - b. Dry any water present in the air intake. Clean the air filter. Filter replacement is required if water is present.
 - c. Remove the spark plugs, keeping plug wires away from the spark plug mounting hole to avoid igniting fuel that may be in the cylinder. Turn the engine over several times using the electric start.
 - d. Dry the spark plugs and reinstall, or replace with new plugs.
 - e. Attempt to start the engine. If necessary, repeat the drying procedure. If engine does not start after three attempts, discontinue trying.
 - f. After driving through water when the air temperature is below freezing, clear the brake system of excess water, snow, mud or other material to prevent freezing.
 - g. If water has been ingested into the clutch enclosure, remove the drain plug to allow water to drain, then reinstall the plug. Run the engine for one minute to dry the drive belt. In Neutral, run engine up to full speed and back down several times to help dry the clutch sheave faces.
 - h. Take the vehicle to your dealer for service as soon as possible, whether you succeed in starting the engine or not. It is critical that services are performed to the engine, transmission, differential fluids, and fuel tank to check for contamination.

RH75544,000016B-19-02MAY13

Checking Wheel Hardware

- A serious accident could occur causing serious injury if wheel hardware is not tight.
- Check wheel hardware tightness often during the first 100 hours of operation.

- Wheel hardware must be tightened to specified torque using the proper procedure anytime it is loosened.

RH75544,000016C-19-08APR13

Wear Appropriate Clothing



MXAL41935—UN—18FEB13

- Always wear an approved helmet when operating the vehicle in an aggressive manner, on rough or uneven terrain, or at higher speeds.
- Helmets should fit properly and be approved for motorcycle use on standard roadways by the appropriate governing organizations for the region in which the vehicle is being used.
- Wear close fitting clothing and safety equipment appropriate for the job.
- Certain operating conditions may dictate that the operator and any passenger wear appropriate safety equipment while operating the vehicle. Be prepared for any existing and potential conditions before operating machine.
- Local safety or insurance regulations may require additional safety equipment such as eye protection or a hard hat.
- Always wear substantial footwear and long trousers. Do not operate the equipment when barefoot or wearing open sandals.

BB87125,0000D4B-19-19APR13

Practice Safe Maintenance



MXAL41933—UN—18FEB13

- Only qualified, trained adults should service this machine.
- Understand service procedure before doing work. Keep area clean and dry.
- Never lubricate, service, or adjust machine while it is moving. Keep safety devices in place and in working condition.
- Keep hands, feet, clothing, jewelry, and long hair away from any moving parts, to prevent them from getting caught.

Safety

- Disconnect battery(ies) or remove spark plug wires (for gasoline engines) before making any repairs.
- Keep all nuts and bolts tightened.
- Securely support any machine elements that must be raised for service work. Lock service latches before working on machine with raised attachments.
- Never run engine unless park brake is locked.
- Keep all parts in good condition and properly installed. Fix damage immediately. Replace worn or broken parts. Replace all worn or damaged safety and instruction decals.
- To prevent fires, remove any buildup of grease, oil, or debris from the machine, especially the engine.
- Do not modify machine or safety devices. Unauthorized modifications may impair its function and safety.
- Do not wear radio or music headphones while servicing the machine. Safe service requires your full attention.
- Disconnect battery ground cable(s) (-) on the machine or remove attachment from machine before welding on the machine.

RH75544,000016E-19-08APR13

Prevent Fires

- Please review these recommendations with all operators. See your John Deere dealer with questions.
- Always follow all safety procedures posted on the machine and in this operator manual. Before carrying out any inspection or cleaning always shut off engine, set parking brake and remove ignition key.
- Besides routine maintenance, one of the best ways to keep your John Deere equipment running efficiently and to reduce fire risk is to regularly remove debris buildup from the machine.
- After operating, allow machine to cool in an open area before cleaning or storing. Do not park machine near flammable materials such as wood, cloth or chemicals, or near an open flame or other sources of ignition, such as a water heater or furnace.
- Completely remove any combustible materials from equipment before storing, by emptying any grass catcher bags, containers and cargo boxes.
- Debris can accumulate anywhere on the machine, especially on horizontal surfaces. Remove grass and debris completely from engine compartment, muffler area, and from the mower deck or cutting units both before and after operating machine. Additional cleaning may be necessary when mowing or mulching in dry conditions.
- In addition to cleaning machine before using and storing, keeping engine area clean provides the greatest impact on fire prevention. Other areas requiring regular inspection and cleaning include

behind wheel rims, wire harness, hose or line routing, mowing attachments, etc. Compressed air, leaf blowers, or high pressured water assists in keeping these areas clean.

- Frequency of these inspections and cleaning will vary depending on a number of factors including operating conditions, machine configuration, operating speeds and weather conditions particularly dry, hot and windy conditions. When you are operating in these conditions, inspect and clean these areas frequently throughout the day.
- Excess lubrication or fuel/oil leaks or spills on the machine can also serve as collection sites for debris. Prompt machine repair and oil and fuel clean-up reduces the potential for debris collection.
- Bearing failures or overheating can result in a fire. To reduce this risk, always follow the instructions in the machine operator's manual regarding lubrication intervals and locations. Contact your local dealer if you have any questions about the lubrication intervals or location and if any unusual noises are coming from areas where bearings might be located. Washing the machine while warm may also reduce bearing life and increase potential for premature bearing failure.
- Always shut off fuel when storing or transporting machine, if the machine has a fuel shutoff.
- Check fuel lines, tank, cap, and fittings frequently for cracks or leaks. Replace if necessary.

OUO2005,0000221-19-07JUL16

Do Not Modify Machine

Do not make any unauthorized modifications to the machine in any way.

Modifications can result in making the machine unstable, increasing the possibility of rollover causing severe bodily injury or death.

RH75544,0000170-19-08APR13

Tire Safety



TICAL25965—UN—24MAY12

Explosive separation of a tire and rim parts can cause serious injury or death:

- Do not attempt to mount a tire without the proper equipment and experience to perform the job.
- Always maintain the correct tire pressure. Do not inflate the tires above the recommended pressure. Never weld or heat a wheel and tire assembly. The heat can cause an increase in air pressure resulting

Safety

in a tire explosion. Welding can structurally weaken or deform the wheel.

- When inflating tires, use a clip-on chuck and extension hose long enough to allow you to stand to one side and NOT in front of or over the tire assembly.
- Check tires for low pressure, cuts, bubbles, damaged rims or missing lug bolts and nuts.

OUO2005.0000222-19-10MAY17

Handling Fuel Safely

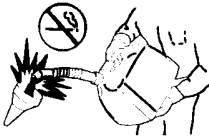

MXAL41938—UN—18FEB13

To avoid personal injury or property damage, use extreme care in handling fuel. Fuel is extremely flammable and fuel vapors are explosive:

- Extinguish all cigarettes, cigars, pipes, and other sources of ignition.
- Use only an approved fuel container. Use only non-metal, portable fuel containers approved by the Underwriter's Laboratory (U.L.) or the American Society for Testing & Materials (ASTM). If using a funnel, make sure it is plastic and has no screen or filter.
- Never remove the fuel tank cap or add fuel with the engine running. Allow engine to cool before refueling.
- Never add fuel to or drain fuel from the machine indoors. Move machine outdoors and provide adequate ventilation.
- Clean up spilled fuel immediately. If fuel is spilled on clothing, change clothing immediately. If fuel is spilled near machine, do not attempt to start the engine but move the machine away from the area of spillage. Avoid creating any source of ignition until fuel vapors have dissipated.
- Never store the machine or fuel container where there is an open flame, spark, or pilot light such as on a water heater or other appliance.
- Prevent fire and explosion caused by static electric discharge. Static electric discharge can ignite fuel vapors in an ungrounded fuel container.
- Never fill containers inside a vehicle or on a truck or trailer bed with a plastic liner. Always place

containers on the ground away from your vehicle before fueling.

- Remove fuel-powered equipment from the truck or trailer and refuel it on the ground. If this is not possible, then refuel such equipment with a portable container, rather than from a fuel dispenser nozzle.
- Keep the nozzle in contact with the rim of the fuel tank or container opening at all times until the fueling is complete. Do not use a nozzle lock-open device.
- Never overfill fuel tank. Replace fuel tank cap and tighten securely.
- Replace all fuel container caps securely after use.
- For gasoline engines, do not use gas with methanol. Methanol is harmful to your health and to the environment.

OUO2005.0000223-19-12OCT16

Handling Waste Product and Chemicals

Waste products, such as, used oil, fuel, coolant, brake fluid, and batteries, can harm the environment and people:

- Do not use beverage containers for waste fluids - someone may drink from them.
- See your local Recycling Center or authorized dealer to learn how to recycle or get rid of waste products.
- A Material Safety Data Sheet (MSDS) provides specific details on chemical products: physical and health hazards, safety procedures, and emergency response techniques. The seller of the chemical products used with your machine is responsible for providing the MSDS for that product.

OUO2005.0000224-19-16AUG13

Use Electronic Display Properly

Electronic displays are secondary devices intended to aid the operator in performing field operations, increase comfort and provide entertainment. Displays offer a wide range of functionality, are used in many different machine system applications and can be used with other secondary devices such as handheld electronic devices.

A secondary device is any device that is not required to operate your machine for its primary use. The operator is always responsible for safe operation and control of the machine.

To prevent injury while operating the machine:

- Position the display according to the installation instructions. Ensure that the device is secured and does not obstruct the driver's view or interfere with the machine operating controls.
- Do not become distracted by the display. Stay alert. Pay attention to the machine and surrounding environment.

Safety

- Do not change settings or access any functions that require prolonged use of the display controls while machine is moving. Stop the machine in a safe location and place in park position before attempting such operations.
- Never set the volume so high that you cannot hear outside traffic and emergency vehicles.

To promote safe operation, certain functions of displays may be disabled unless the machine movement is restricted and/or has been placed in the park position. Overriding this safety feature may violate applicable law and can result in damage, serious injury, or death.

Only use available display functionality when conditions permit you to do so safely and in accordance with instructions provided. Always observe safe driving rules, state, or local laws and traffic regulations when using any secondary device.

DX,ELEC,DISPLAY-19-13JAN15

Machine Cleanout

General Cleaning Guidelines

Machine must be inspected periodically throughout the day. Buildup of debris must be removed to ensure proper machine function and to reduce the risk of fire. Frequency of these inspections and cleanings will vary depending on a number of factors including operating conditions, machine configuration, operating speeds, and weather conditions. Inspections and cleanings may be required multiple times throughout the day particularly in dry, hot, and windy conditions.

IMPORTANT: Regular and thorough cleaning of machine combined with other routine maintenance procedures listed in the Operator's Manual greatly reduce the risk of fire, downtime and improve machine performance.

Besides proper maintenance the condition of the material being handled is the most significant factor contributing to fires. Dry, light and fluffy materials that can create a dust cloud are the most likely to catch fire. Debris can accumulate in various areas especially on horizontal surfaces. Conditions such as wind speed and direction can change where the material accumulates. Be aware of these changing conditions and adjust your cleaning schedule and practices to ensure proper machine function and to reduce the risk of fire.

Always follow all safety procedures posted on the machine and in the Operator's Manual. Before carrying out any inspection or cleaning, always shut OFF engine, set parking brake and remove key.

The entire machine should be inspected, with extra attention given to the areas noted below.

OUMX068.0001043-19-10MAY17

Cleanout Areas

Primary areas that must be inspected and cleaned on the machine include (See Safety Label Section):

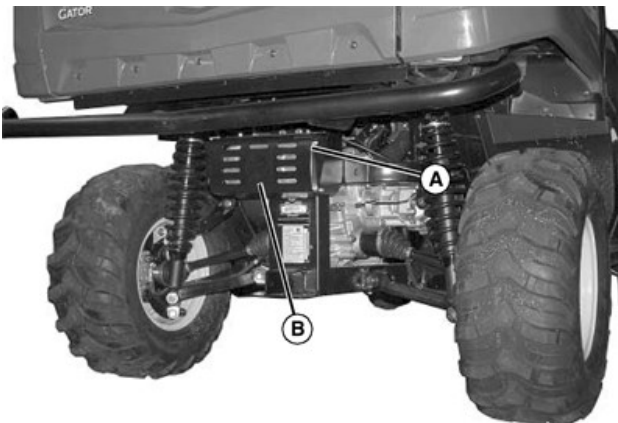

MXAL47292—UN—16APR13

- Muffler (A) and muffler shield (B).

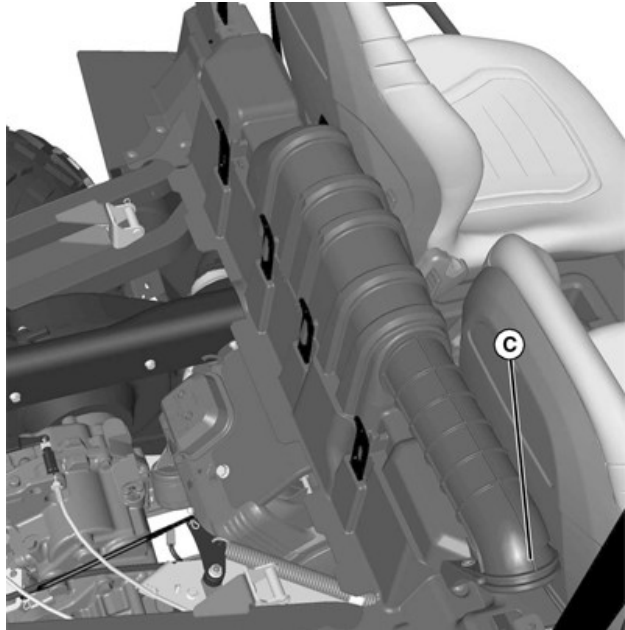

MXAL47293—UN—16APR13

- Engine intake screens (C).

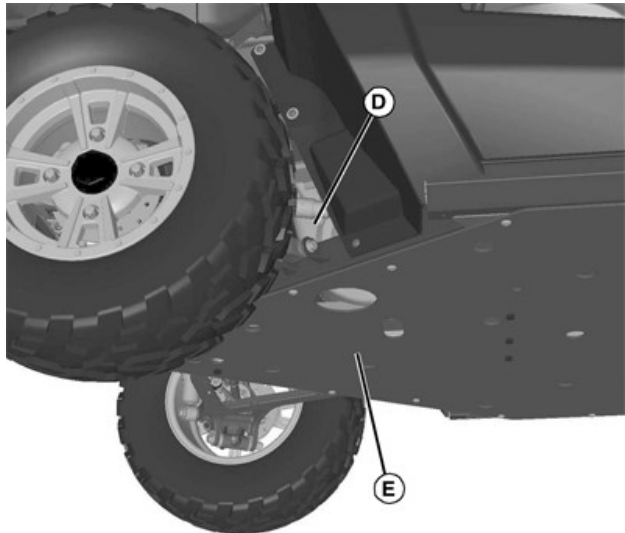

MXAL47294—UN—16APR13

- Between engine (D) and skid plates (E) (if equipped).

Machine Cleanout

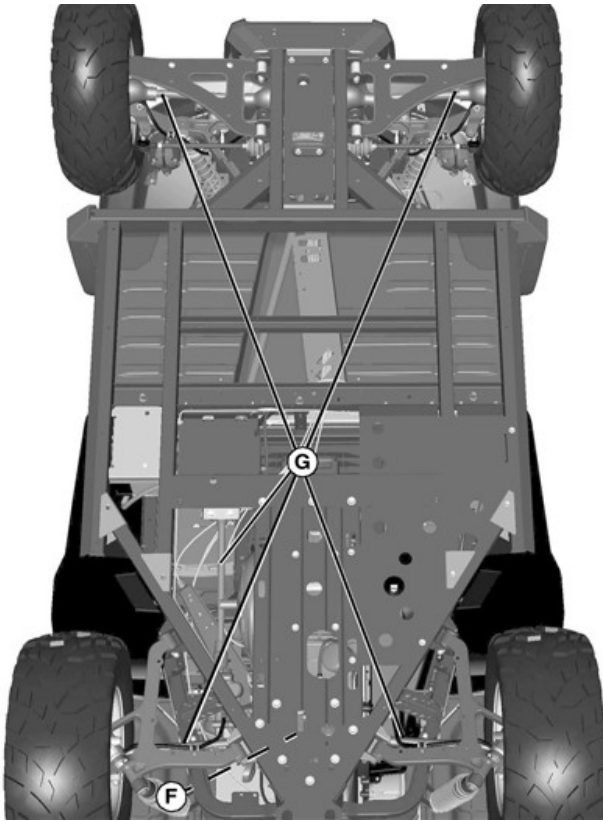

MXAL47295—UN—16APR13

- On or near transmission (F) and drive line (G).

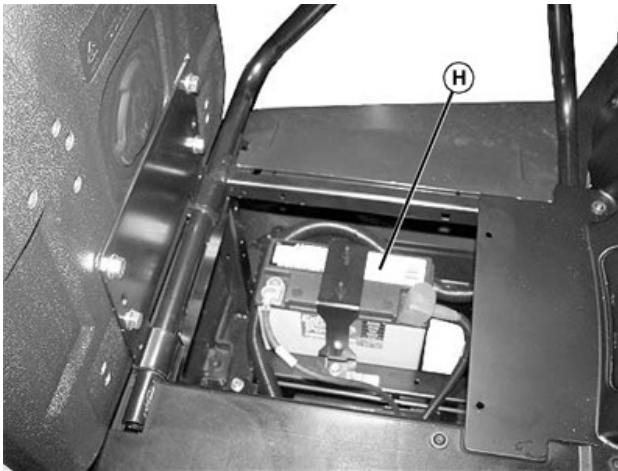

MXAL47296—UN—16APR13

- Battery (H) and related wiring harnesses.

OUMX068,0000B8B-19-06MAY15

Operating Controls

Operator Station Controls

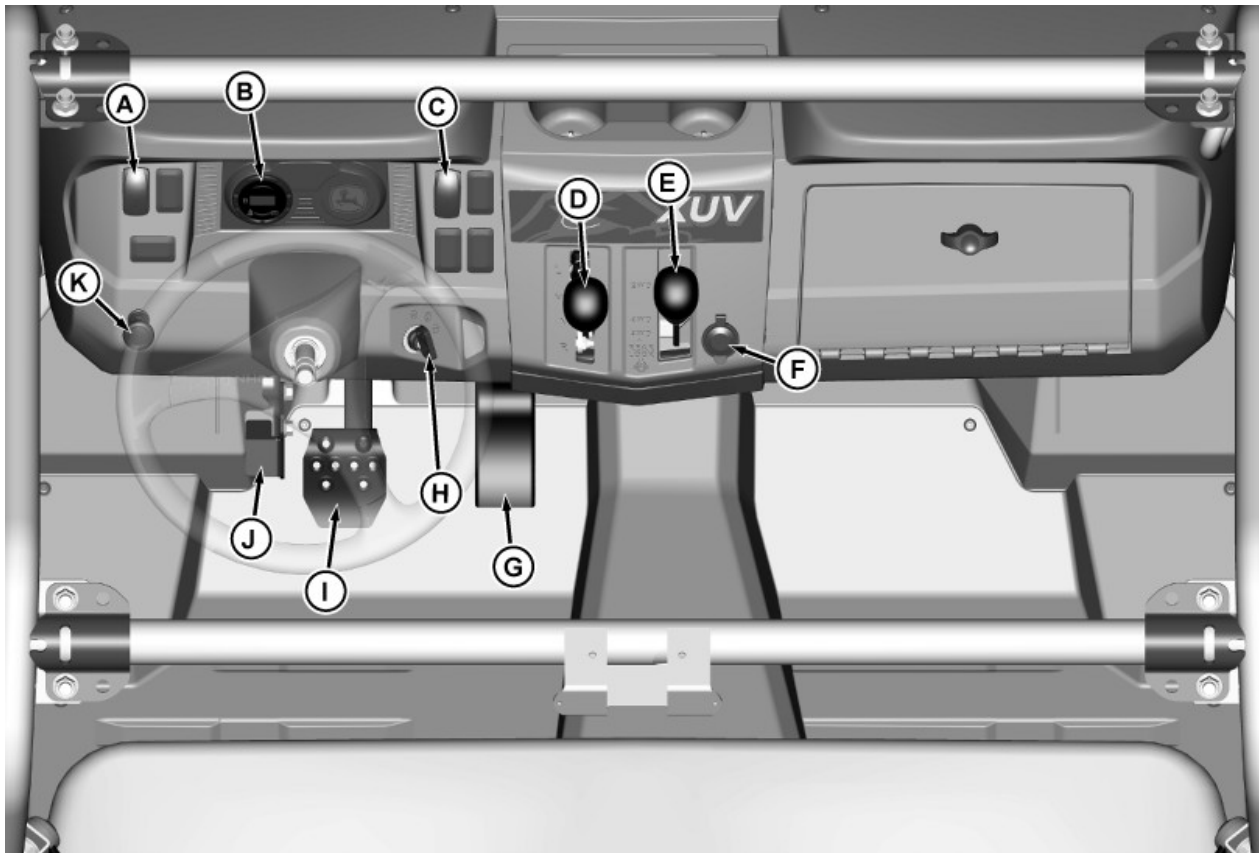

MXT020151—UN—17MAY17

Some controls may not be installed on your machine.

- A**—Cargo Box Power Lift Switch
- B**—Hourmeter and Service Reminder
- C**—Headlight Switch
- D**—Transaxle Shift Lever
- E**—2WD/4WD Lever
- F**—12V DC Accessory Outlet
- G**—Accelerator Pedal
- H**—Ignition Key Switch
- I**—Brake Pedal
- J**—Park Brake Pedal
- K**—Choke

OUMX068,000129A-19-17MAY17

Operating

Daily Operating Checklist

- Test safety systems.
- Check tire pressure.
- Check fuel level.
- Check engine oil level.
- Remove grass and debris from engine compartment, muffler area, and front grille, before and after operating machine.
- Check area below machine for leaks.
- Check brakes and park brake operation.
- Inspect driveline CV boots for tears or punctures.
- Inspect steering tie rod boots for tears or punctures.
- Tighten any loose hardware.
- Check seat belt function.
- Check nets or doors function.

OUMX068,00002E4-19-04OCT13

Avoid Damage to Plastic and Painted Surfaces

- Do not wipe plastic parts unless rinsed first.
- Insect repellent spray may damage plastic and painted surfaces. Do not spray insect repellent near machine.
- Be careful not to spill brake fluid on machine components. Brake fluid may damage painted surfaces. Wipe up spilled brake fluid immediately.
- Be careful not to spill fuel on machine. Fuel may damage surface. Wipe up spilled fuel immediately.

BB87125,0000D55-19-19APR13

Using Nets

CAUTION: Avoid injury! Do not operate vehicle with nets removed. Always park vehicle safely before opening net to exit.

Do not operate vehicle with nets or doors in the open position. All nets or doors must be closed while the vehicle is in use.

Entering vehicle:

1. Move net rearward out of entry and exit area, and enter vehicle.

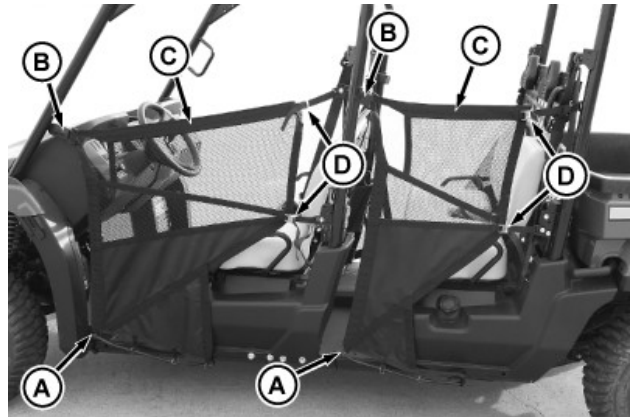

MXT016164—UN—22OCT15

Picture Note: XUV560 S4 model shown.

2. Move bottom of net fully forward (A) and insert metal tab of net into buckle (B) until it latches.
3. After entering and exiting vehicle several times, check to be sure that the top strap (C) of the net is taut when net is latched. Tighten or loosen net at adjusting buckles (D) as needed.

Exiting vehicle:

1. Park vehicle safely.
2. Push button to release metal tab from buckle (B).
3. Move net rearward out of entry and exit area, and exit vehicle.

OUMX068,0000E57-19-27OCT15

Using Hand Holds (Bucket Seat)

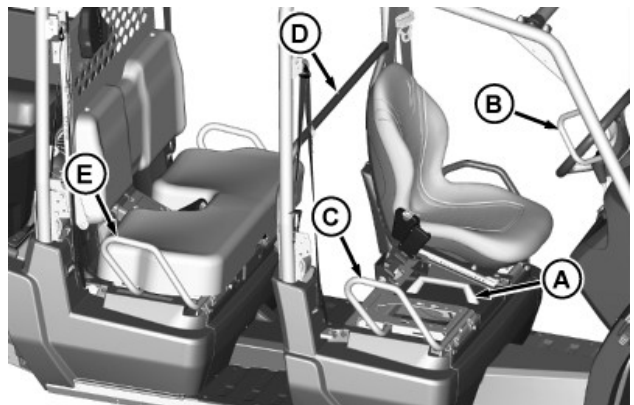

MXT016184—UN—03NOV15

Picture Note: XUV560 S4 model shown. Passenger seat hidden for better view.

Hand holds are provided for passenger balance.

- When a front seat passenger is present, they must use two of the three hand holds at all times while the machine is moving: The center handle (A), Protective Structure handle (B), or side rail (C).
- When a rear seat passenger is present, they must

Operating

use one of the two hand holds at all times while the machine is moving: rear grab bar (D) or side rail (E).

OUMX068,0000EA3-19-04NOV15

Using Hand Holds (Bench Seat)

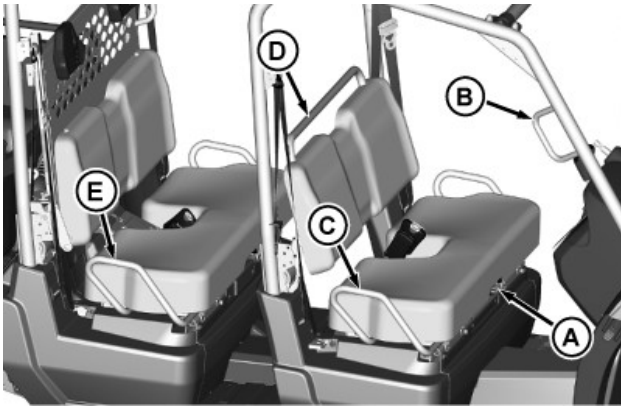

MXT016159—UN—26OCT15

Picture Note: XUV560 S4 model shown.

Hand holds are provided for passenger balance.

- When a front seat passenger is present, they must use two of the three hand holds at all times while the machine is moving: The center hand grip (A), Protective Structure handle (B), or side rail (C).
- When a rear seat passenger is present, they must use one of the two hand holds at all times while the machine is moving: seat handle (D) or side rail (E).

OUMX068,0000E4D-19-03NOV15

Adjusting Bucket Seat

CAUTION: Avoid injury! Never adjust seat while machine is moving. To prevent loss of machine control, stop machine before adjusting seat.

1. Stop machine and move transaxle shift lever to the neutral position.
2. Lock park brake.



MXT016188—UN—30OCT15

3. Pull out on lever (A) and slide seat forward or rearward until seat locks in place.
4. Release lever.

OUMX068,0000EA7-19-30OCT15

Using Bench Seat Fold Down Rack

For extra storage or cargo box capacity, fold down the rear bench seat cargo rack.

CAUTION: Avoid injury! Fingers and hands can be pinched or crushed. Be aware of potential pinch points and keep hands away.

Lowering Bench Seat with Fold Down Rack

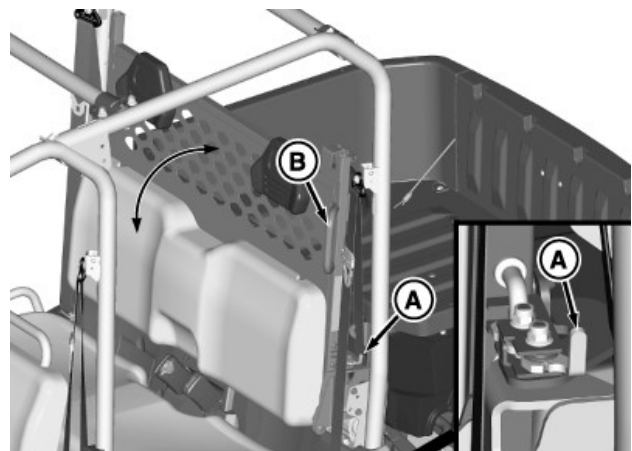

MXT013629—UN—11MAY15

1. Push latch lever (A) inward and use handle (B) to lower seat.

Using Cargo Rack

CAUTION: Avoid injury! Riders can fall off and be injured or killed. Never carry riders in or on an attachment.

IMPORTANT: Avoid damage! Do not allow load to exceed width of fold-down rack and machine. Do not load cargo rack beyond weight capacity of 90 kg (200 lb.).

Operating

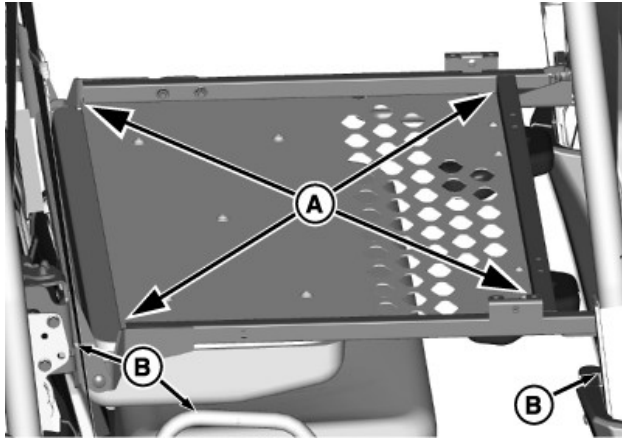

MXT013631—UN—27MAR15

1. Arrange load so the weight is centered over the main cargo area (A).
2. Secure the load to the tie-downs (B) on both sides in a safe and secure manner.

Raising Bench Seat with Fold Down Rack

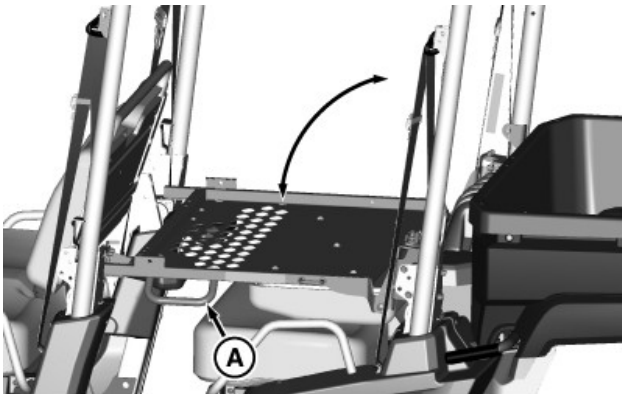

MXT017462—UN—08SEP16

1. Remove load from cargo rack.
2. Raise seat and cargo rack using handle (A).

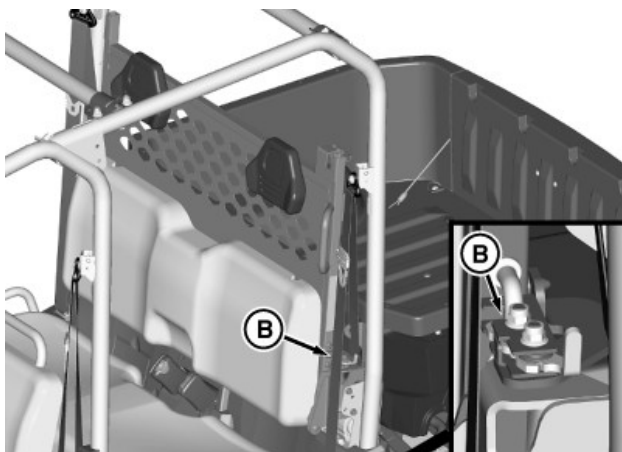

MXT017463—UN—08SEP16

3. Raise assembly until latch (B) secures cargo rack in raised position.

KL66860,0000BC-19-09SEP16

Using Seat Belt

NOTE: Shoulder harness is sensitive. An emergency lock device is built into the belt for your protection. To engage harness, pull harness slowly. Attempting to pull too fast or in a jerking motion engages the locking mechanism and the harness does not release.

Periodically inspect seat belts for wear or damage. See Inspecting Seat Belt in SERVICE MISCELLANEOUS.

Fasten Belt

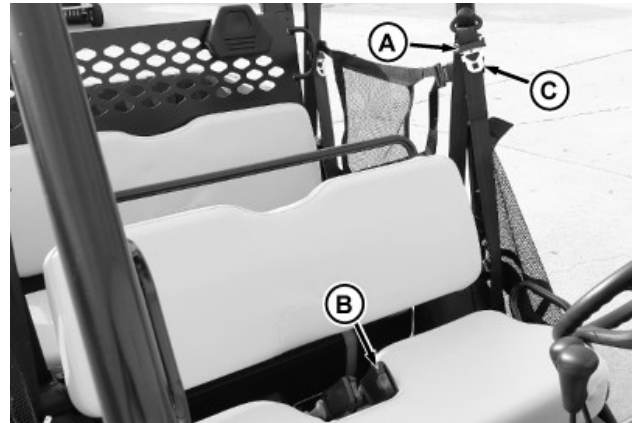

MXT016160—UN—21OCT15

Picture Note: Machine with front bench seat shown. Seat belt components are in same locations with front bucket seats.

1. Grasp outer seat belt connector (A) from behind seat, pull out and across body to inner connector (B), at inside of seat.
2. Adjust outer connector up or down along belt for best fit.
3. Push outer connector lower half (C) firmly into inner connector until it locks.
4. Snug the seat belt across the hips, on top of the thighs.

Release Belt

1. To release seat belt, press red button on inner connector.

OUMX068,0000E4F-19-06NOV15

Operating

Testing Safety Systems

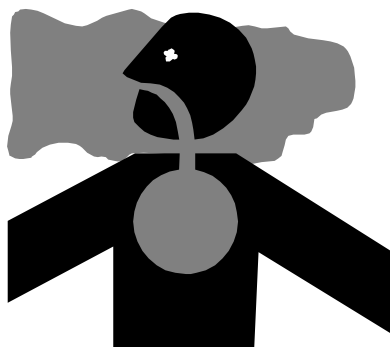

MXAL41828—UN—18FEB13

CAUTION: Engine exhaust fumes contain carbon monoxide and can cause serious illness or death.

Do not run an engine in an enclosed area, such as a garage, even with doors or windows opened.

Move the machine to an outside area before running the engine.

The safety systems installed on your machine should be checked before each machine use. Be sure you have read the machine operator manual and are completely familiar with the operation of the machine before performing these safety system checks.

Use the following checkout procedures to check for normal operation of machine.

If there is a malfunction during one of these procedures, do not operate machine. **See your authorized dealer for service.**

Perform these tests in a clear open area. Keep bystanders away.

BB87125,0000D5A-19-14MAY13

Testing the Safety Start System

NOTE: The engine can start with the transaxle in gear. The machine has a brake pedal safety start switch. The brake pedal must be pushed down to start the engine.

1. Sit on the operator's seat.
2. Turn ignition key switch to STOP position.
3. Lock park brake.
4. Move transmission shift lever to N (Neutral) position.
5. Turn ignition key switch to START position. Engine should not crank. Turn ignition key switch to STOP position.
6. Push down on brake pedal.

7. Turn ignition key switch to START position. Engine should crank, allowing engine to start.
8. Allow engine to run a few seconds.
9. Turn ignition key switch to STOP position.

OUMX068,0000BBC-19-04MAY15

Using Park Brake

NOTE: The engine will stop if you push down on the accelerator pedal when the park brake is locked.

CAUTION: Avoid injury! Children or bystanders may attempt to move or operate an unattended machine.

Always lock the park brake and remove the key before leaving the machine unattended.

Locking the Park Brake:

1. Push down firmly on park brake pedal in one motion until several clicks are heard.
2. Be sure that machine is motionless before getting off the seat.

Unlocking the Park Brake:

1. Push down on park brake pedal until you hear audible click and brakes release.

OUMX068,0000BBB-19-04MAY15

Using Travel Controls

1. Stop machine.
2. Allow engine to come to a low idle speed.

IMPORTANT: Avoid damage! Do not shift gears when vehicle is moving or with engine running above low idle speed. Push down brake to stop vehicle motion and engage shift lever with a firm positive action.

Gears can grind when shifting or shifting can become hard.

NOTE: Always shift into low range when operating on wet, uneven or steep terrain, when towing or pushing heavy loads, or operating less than 10 mph.

Operating

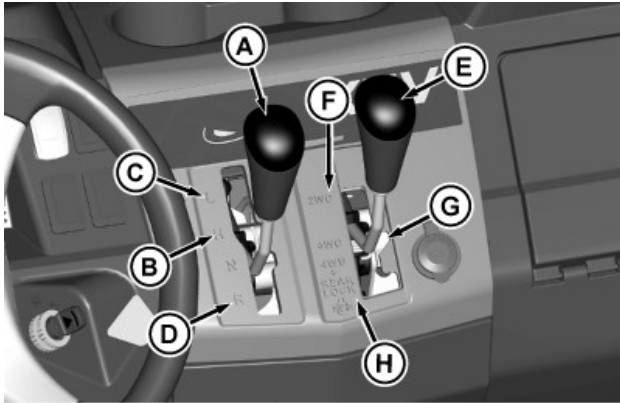

MXT016176—UN—28OCT15

3. Select a gear position:
 - Forward - Push transaxle shift lever (A) up to either High (B) or Low (C) range.
 - Reverse - Pull lever down to Reverse (D) gear.
4. Select 2WD or 4WD position:
 - Push 2WD/4WD lever (E) up to the 2WD position (F).
 - Pull 2WD/4WD lever (E) down to the 4WD position (G).
5. Look in the direction the machine will travel.

CAUTION: Avoid injury! Driving at high speeds with Rear Lock engaged can result in loss of steering control. Do not engage Rear Lock or turn with the Rear Lock engaged while operating machine at high speeds or on slopes.

- Pull 2WD/4WD lever (E) fully down to the 4WD + Rear Lock position (H). See Using Rear Lock instructions before operating machine with rear lock engaged.

CAUTION: Avoid injury! Reduce speed before braking or turning, when hauling loads, and while operating around obstacles or on hazardous off-road conditions.

6. Push down accelerator pedal slowly and smoothly to begin machine travel.
7. Release accelerator and apply brake pedal evenly and firmly to slow down or stop.

KL66860,00000C5-19-13SEP16

Using Rear Lock

CAUTION: Avoid injury! Driving at high speeds with Rear Lock engaged can result in loss of steering control. Do not turn machine with Rear Lock engaged while operating machine at high speeds or on slopes.

Rear Lock provides better traction when rear wheels start to slip. Engaging Rear Lock causes both rear wheels to turn together at equal speed.

Engaging Rear Lock:

IMPORTANT: Avoid damage! Incorrectly using Rear Lock can damage the transaxle.

Stop machine before engaging or disengaging Rear Lock.

1. Stop or reduce engine speed to 1/3 throttle or less.
2. Pull 2WD/4WD lever down to the 4WD + Rear Lock position:
 - Rear Lock remains engaged as long as lever is in 4WD + Rear Lock.

Disengaging Rear Lock

NOTE: To ensure true disengagement of Rear Lock, torque on both axles must be equalized.

1. Stop machine travel.
2. Push 2WD/4WD lever up to center 4WD or top 2WD position.

OUMX068,0000E67-19-01DEC15

Using Four Wheel Drive

The machine is equipped with a manual shift four-wheel drive (4WD) system. This system allows the power train to drive the front wheels in addition to the rear wheels for improved traction on difficult ground conditions.

CAUTION: Avoid injury! 4WD greatly increases traction and can make dangerously sloped terrain accessible, increasing possibility of a tip-over.

Use extra caution when driving on slopes. To increase traction, use 4WD when driving on slopes.

Use 4WD when driving on icy, wet, or graveled surfaces; reduce speed to avoid skidding and loss of steering control.

IMPORTANT: Avoid damage! Do not engage 4WD when the rear wheels are slipping, internal gears can be damaged. Machine must be stopped or traveling at a steady speed, in a straight line, to engage 4WD.

- To engage 4WD, pull 2WD/4WD lever down to the 4WD position.
- To engage 2WD, push 2WD/4WD lever up to the 2WD position.

Operating

⚠ CAUTION: Avoid injury! Front implements can cause decreased traction at the rear wheels resulting in loss of control. Always operate machine with 4WD engaged when front implements are attached.

Tips for operating 4WD:

- To ensure optimum performance on all surface conditions, maintain recommended front and rear tire pressures.
- To increase front tire life and reduce drivetrain wear, disengage 4WD when driving machine on paved or hard packed surfaces.

OUMX068,0000E68-19-26OCT15

- To turn on headlights or running tail light (if equipped), press top of light switch.
- To turn on running tail light only (if equipped), press top of light switch to the middle position.

NOTE: Be sure to turn off lights and turn the ignition key switch to STOP position, or lights discharge the battery.

- Press bottom of light switch to turn off headlights or running tail light (if equipped).

OUMX068,0000A87-19-13NOV14

Using Ignition Key Switch



MXT020180—UN—12JUN17

Ignition key switch labels

A - STOP Position - With key in STOP position, all switched power is off, and engine should not run.

B - RUN Position - Turn key from STOP to this position and all switched power circuits will be on.

C - START Position - Turn key to START position to crank the engine. Release key after engine has started and it will automatically return to the RUN position. The engine will continue to run.

D - Depress the brake pedal and turn the key to the START position to start the engine.

OUMX068,00012CC-19-12JUN17

Using Headlights

Ignition key switch must be in the RUN position to operate the lights. If the ignition key switch is in the RUN position and the engine is not running, the battery discharges if the lights are allowed to remain on for an extended time period.

Using Instrument Panel

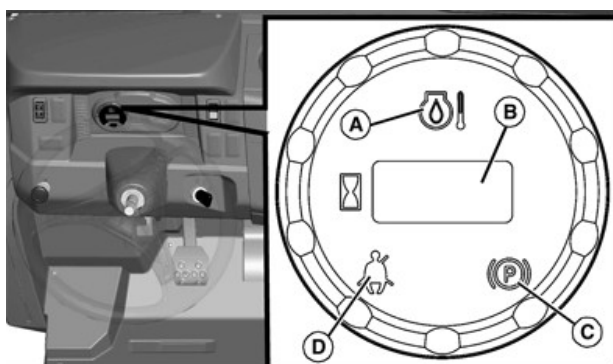

MXAL47305—UN—16APR13

A - Engine Oil Temperature Light (Optional Kit) - This light will illuminate when the ignition key switch is in the RUN position and the engine is not running. If this light turns on while the engine is running, engine oil temperature is too high. Stop engine. See Prevent Fires block in MACHINE CLEANOUT to clean all machine areas, or determine cause by using your machine Technical Manual.

B - Hourmeter - The hourmeter shows the accumulated number of hours the engine has run. The hourmeter displays hours with the ignition key switch in the RUN position, and accumulates and displays hours when the engine is running. The hourmeter is intended to provide a means of monitoring machine usage for maintenance purposes. Use the hourmeter to determine when your machine has reached the recommended service intervals.

C - Park Brake Light - This light will illuminate when the ignition key switch is in the RUN position and the park brake is partially or fully engaged into the locked position.

D - Seat Belt Indicator Light - This light will illuminate if the seat belt is not adequately secured.

BB87125,0000D60-19-14MAY13

Operating

Using Accessory Outlet

CAUTION: Safe operation requires your full attention. Do not wear radio or music headphones while operating machine.

NOTE: Accessory must be rated at 10 amps or less.

The accessory plug does not turn off with the key switch. Items connected to the accessory plug will continue to draw power, discharging the battery.

- Remove 12-volt outlet cover and install accessory cord in outlet.
- Install cover in outlet after use.

BB87125,0000D61-19-19APR13

Using Turn Signal Switch (If Equipped)

NOTE: Turn signals will continue to flash when the ignition key switch is in the STOP position, discharging the battery.

- Press at left end of turn signal switch to signal a left turn.
- Press at right end of turn signal switch to signal a right turn.
- Press at opposite end of turn signal switch until switch is centered to turn signal light off.

BB87125,0000D62-19-19APR13

Using Hazard Lights (If Equipped)

NOTE: Hazard lights will continue to flash when the ignition key switch is in the STOP position, discharging the battery.

- Press at top of hazard light switch to turn hazard lights on.
- Press at bottom of hazard light switch to turn hazard lights off.

OUMX068,0000EA9-19-30OCT15

Using Storage Trays

CAUTION: Avoid injury! Never store flammable, heavy, or loose breakable objects in the storage tray. Always latch hood before operating machine.

IMPORTANT: Avoid damage! Do not store items that will not allow the hood to close properly. Properly secure loose or sharp items. These items may damage the storage tray or other items within the tray.

Under Hood

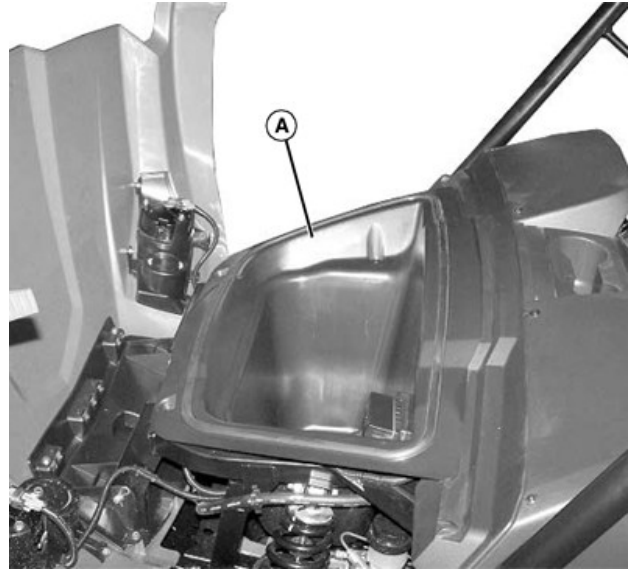

MXAL47306—UN—16APR13

Under hood storage tray (A) is located in front of machine under the hood.

1. Open hood to access the storage tray.
2. Secure all items to prevent damage from movement while operating the machine.
3. Close hood.

Under Seat (XUV560 with Front Bench Seat)

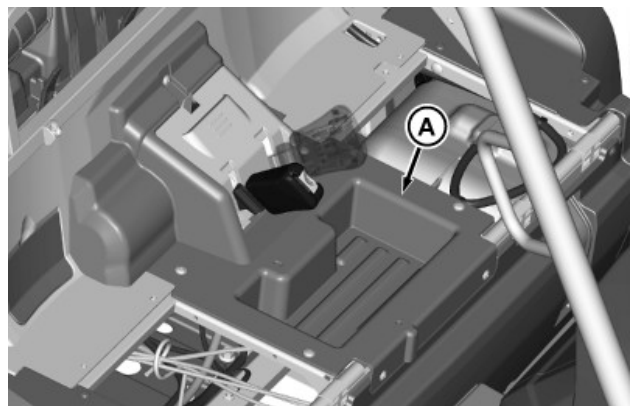

MXT016238—UN—03NOV15

Under seat storage tray (A) is located under bench seat.

1. Raise bench seat to access the storage tray.
2. Secure all items to prevent damage from movement while operating the machine.
3. Lower bench seat.

Operating

Under Seat (XUV560 S4 with Front Bench Seat)

Front Seat

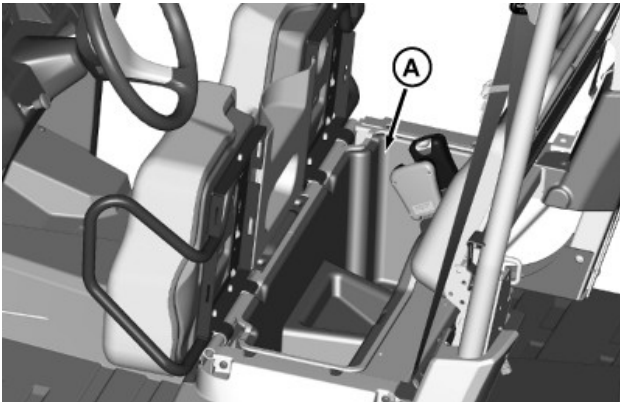

MXT016170—UN—23OCT15

Under seat storage tray (A) is located under front bench seat.

1. Raise front bench seat to access the storage tray.
2. Secure all items to prevent damage from movement while operating the machine.
3. Lower bench seat.

Rear Seat

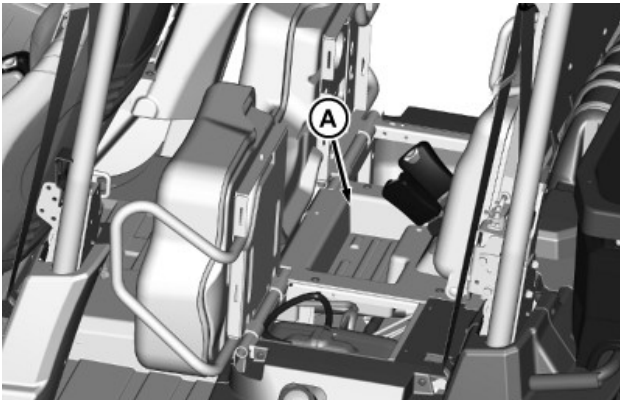

MXT016186—UN—30OCT15

Under seat storage tray (A) is located under rear bench seat.

1. Raise rear bench seat to access the storage tray.
2. Secure all items to prevent damage from movement while operating the machine.
3. Lower bench seat.

Under Seat (XUV560 S4 with Front Bucket Seat)

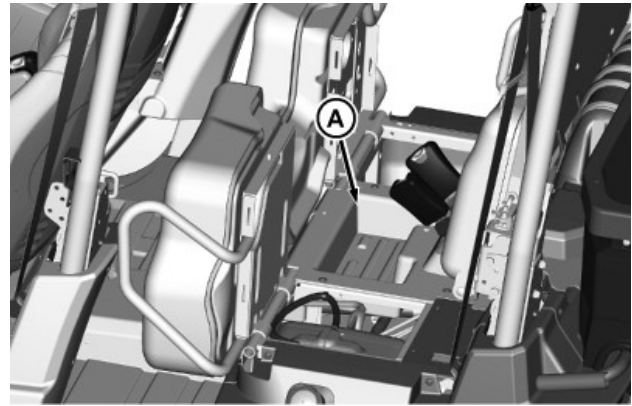

MXT016186—UN—30OCT15

Under seat storage tray (A) is located under rear bench seat.

1. Raise rear bench seat to access the storage tray.
2. Secure all items to prevent damage from movement while operating the machine.
3. Lower bench seat.

OUMX068,0000E5E-19-03NOV15

Starting the Engine

⚠ CAUTION: Avoid injury! Engine exhaust fumes contain carbon monoxide and can cause serious illness or death.

- Move the machine to an outside area before running the engine.
- Do not run an engine in an enclosed area without adequate ventilation.
- Connect a pipe extension to the engine exhaust pipe to direct the exhaust fumes out of the area.
- Allow fresh outside air into the work area to clear out the exhaust fumes.

⚠ CAUTION: Avoid injury! Do not start engine by shorting across starter terminals.

Do not use starting fluid to aid engine starting.

Never start engine while standing on ground. Start engine only from operator's seat.

1. Sit on the operator seat and fasten seat belt. Do not start engine.
2. Push down on accelerator pedal to check free movement of pedal assembly. Release pedal.
3. Move transmission shift lever to N (Neutral) position.
4. Lock the park brake.

Operating

NOTE: The engine can start with the transaxle in gear. The machine has a brake pedal safety start switch. The brake pedal must be pushed down to start the engine.

On some machine models, starter crank protection may engage and you will be unable to crank the engine for approximately ten seconds.

5. Push and hold the brake pedal down to engage the safety start switch.
6. Turn ignition key switch to START position.

IMPORTANT: Avoid damage! Turn off the choke as soon as possible. Running the engine with the choke on beyond the warm-up period leads to plug fouling.

7. If engine is cold, pull out choke control fully and hold.
8. When engine starts, release ignition key switch to the RUN position.
 - If engine does not start within five seconds, turn ignition key switch to STOP position and wait ten seconds before trying to start again.
 - In cold conditions, attempt starting engine three times only, then wait 5 minutes before trying again. This allows time for the starter to cool and prevent damage to starter.
9. Move choke control out and in as needed until engine is running smoothly.
10. Release choke control.

IMPORTANT: Avoid damage! Do not operate the engine at full throttle or under load until engine has warmed up, or engine damage could occur.

11. If you want to warm up the engine manually with the accelerator pedal, first shift to N (Neutral), unlock the park brake, and push down on the brake pedal. Engine stops if the accelerator pedal is pushed down when in N (Neutral) with the park brake locked.
12. To allow the machine to move, unlock the park brake.

OUMX068,00012CD-19-12JUN17

Stopping Engine

 **CAUTION: Children or bystanders may attempt to move or operate an unattended machine.**

Always lock the park brake and remove the key before leaving the machine unattended.

IMPORTANT: Do not stop engine immediately after hard or extended operation. Keep engine running at low idle for a few seconds to prevent heat build-up.

1. Stop machine.
2. Move transaxle shift lever to N (Neutral) position.
3. Lock park brake.
4. Turn ignition key switch to STOP position.
5. Remove key.

BB87125,0000D66-19-19APR13

Emergency Stopping

1. Remove foot from travel pedal or accelerator pedal.
2. Depress brake pedal. Do not release brake pedal until machine has stopped.
3. After machine has stopped, lock the park brake.
4. Turn ignition key switch to STOP position.

BB87125,0000D67-19-19APR13

Using the Cargo Box

 **CAUTION: Avoid injury! Seating is provided for the operator and one passenger. Do not allow riders in the cargo box or on the tailgate. Extra riders can fall off and be seriously injured or killed.**

Raising and Lowering with Manual Lift

 **CAUTION: Avoid injury!**
Park machine on a level surface and lock park brake before manually raising and securing cargo box in raised position.
A cargo box containing material can be heavy. Empty some or all material until cargo box can safely be raised manually.

1. Park the machine safely. (See Parking Safely in SAFETY.)
2. Empty cargo box by hand.

Operating

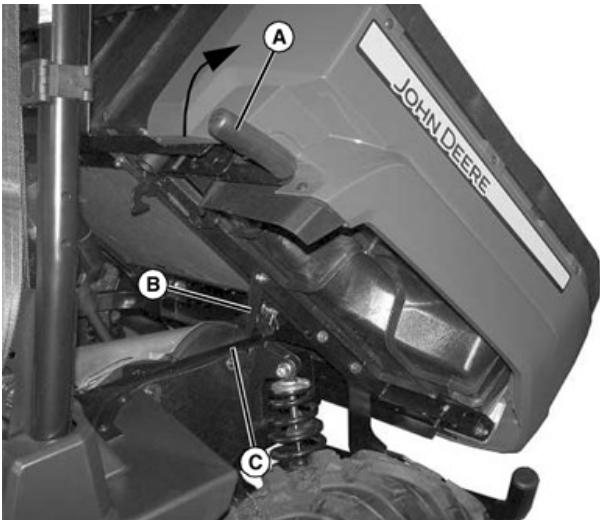

MXAL47307—UN—16APR13

3. Rotate handle (A) upward and raise cargo box. While holding cargo box in position, lower latch support (B) downward and lower cargo box latch support onto frame (C).
4. To lower cargo box, raise latch support (B) and slowly push cargo box downward until it latches in fully lowered position.

Raising and Lowering with Power Lift

IMPORTANT: Avoid damage! A clicking or grinding sound when cargo box is fully raised or lowered or when box is heavily loaded indicates that the power lift cannot apply any more force. To prevent unnecessary wear or damage, keep sound to a minimum. Do not operate the power lift actuator beyond full stroke or exceed the cargo box weight capacity.

1. Park the machine safely. (See Parking Safely in SAFETY.)
2. Empty cargo box by hand.
3. Turn ignition key switch to RUN position.
4. Raise cargo box by pressing and holding top of cargo box power lift switch. Release switch when box is at desired dump height or when reaching maximum height.
5. Lower cargo box by pressing and holding bottom of cargo box power lift switch.
6. Turn ignition key switch to STOP position.

Locking Box in Raised Position

CAUTION: Avoid injury! If not secured properly, cargo box can fall. Remove key from ignition and lower latch support onto frame before doing any service under raised cargo box.

1. Raise the cargo box.



MXAL47309—UN—16APR13

2. Lower latch support (A) downward and lower cargo box latch support onto frame (B).
3. Check to be sure that box is locked in raised position.
4. To lower cargo box, raise latch support (A) up and slowly push cargo box downward until it latches in fully lowered position.

Operating the Tailgate

CAUTION: Avoid injury! Never operate tailgate with one lanyard attached (always use both). Check condition of lanyards for wear or damage. Replace if cable is kinked or frayed.

IMPORTANT: Avoid damage! Do not attempt to tilt or dump cargo box when lanyards are detached. Tailgate damage results.

To avoid jamming material in the gap between the cargo box bed and tailgate, keep lanyards attached when loading and unloading loose materials.



MXAL47310—UN—16APR13

1. Check to be sure lanyards (A) are in place for supporting lowered tailgate.

Operating

2. Disconnect lanyards only if you want to remove tailgate.
3. To unlock and lower tailgate, pull back on handle (B).
4. Before raising tailgate, check for stones and debris caught in the gap between the tailgate and cargo box floor. To remove debris:
 - To secure the cargo box in raised position, use latch support.
 - Rotate the tailgate slightly to free debris, and brush out the gap.
 - Lower the cargo box.
5. To raise tailgate, slowly push tailgate upward and lock into closed position.
6. Check to be sure that tailgate is securely locked.

Using Cargo Box Tie Downs

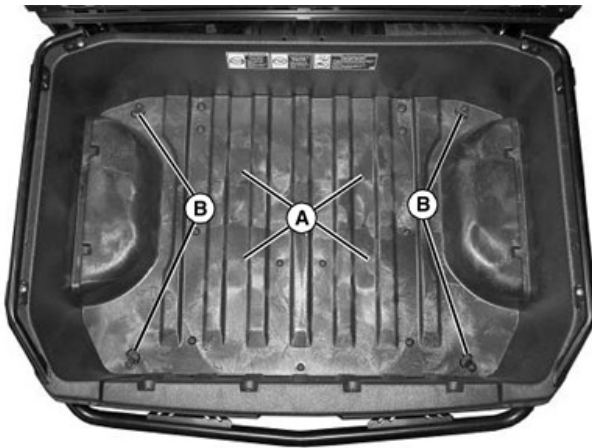

MXAL47311—UN—16APR13

1. Arrange load so the weight is centered over the main cargo area (A).
2. Secure loads to the tie-downs (B) in a safe and secure manner.

Removing the Tailgate



MXAL47312—UN—16APR13

1. Check to be sure lanyards (A) are in place for supporting lowered tailgate.
2. Pull back on handle (B) to unlock and lower tailgate (C).

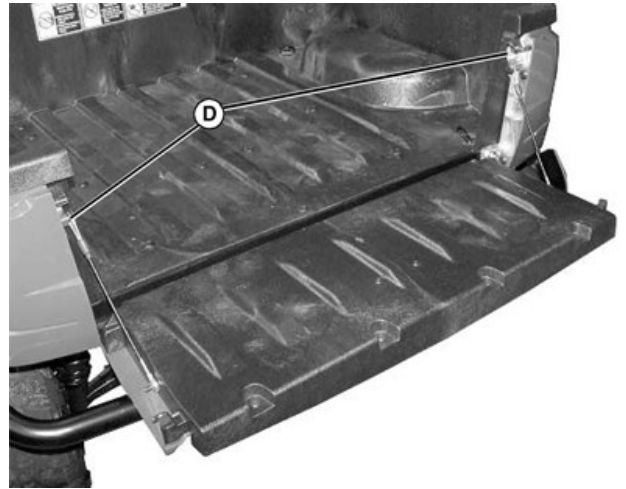

MXAL47313—UN—16APR13

3. Remove top loop (D) on top of lanyards from studs on cargo box side, and lower tailgate downward.

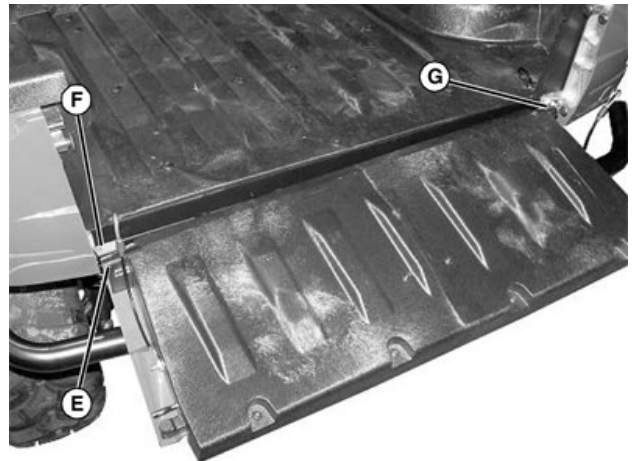

MXAL47314—UN—16APR13

4. Lower tailgate so that slotted opening (E) on tailgate matches pin (F) on side panel. Remove left side of tailgate first and then remove right side (G) and entire tailgate assembly from side panel.
5. Install in reverse order of removal.

OUMX068,0000E50-19-22OCT15

Determining Vehicle Load Capacity

Find weights and capacities for your machine model in SPECIFICATIONS.

CAUTION: Avoid injury! Overloading the vehicle or trailer causes loss of control and causes serious injury or death.

- Do not allow the Gross Vehicle Weight (GVW)

Operating

to exceed the **Gross Vehicle Weight Rating (GVWR)** of the vehicle.

- Remove excess weight before operating vehicle.

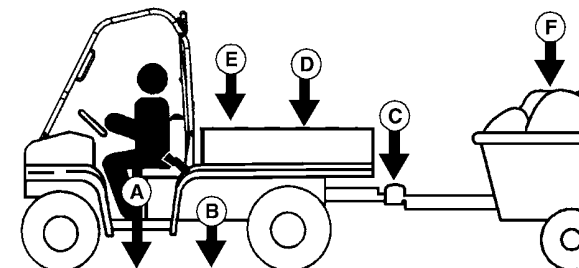

MXAL47315—UN—16APR13

The picture shows a Protective Structure installed on a two-passenger machine. Some machines do not have a Protective Structure installed as some models are not designed to include it.

Factors in Determining Vehicle Load Capacity

NOTE: Optional equipment, and attachments that are not standard equipment, reduce your cargo box capacity; so they must be included when determining gross vehicle weight.

- **Gross Vehicle Weight (GVW)** is the combination of the empty vehicle weight, payload, trailer tongue weight, and the weight of any other kits or attachments on the vehicle.

$$GVW = A+B+C+D+E$$

- **Gross Vehicle Weight Rating (GVWR)** is the maximum permissible vehicle weight.
- **Payload** is the weight of all occupants plus the cargo box load.
- **(A) Occupant load** is the combined weight of the operator and passenger (or passengers).
- **(B) Empty vehicle weight** is the weight of the vehicle (full fluids) without occupants or load or attachments.
- **(C) Trailer tongue weight** is the weight measured if the tongue of a loaded trailer was placed on a scale. The tongue weight must be approximately 10% of the total of the trailer weight and the weight of its load.
- **(D) Cargo box load** is the weight of the cargo in the cargo box. It is less depending on the weight of the occupants, attachments, and the trailer tongue weight.
- **(E) Attachment and option weight** is the combined weight of all attachments and options that were not standard equipment. For help with this information, contact your John Deere dealer.
- **Vehicle load capacity** is the remaining amount of weight that the vehicle is able to haul in the cargo box. (Or cargo box plus the additional weight from the

operator, passenger (or passengers), trailer tongue, and attachments.)

- **Determine maximum vehicle load capacity:**
 - a. Calculate $GVW = A+B+C+D+E$
 - b. Subtract the Gross Vehicle Weight (GVW) from the Gross Vehicle Weight Rating (GVWR).
 - c. The weight difference between the two numbers is the vehicle load capacity.

$$\text{Vehicle Load Capacity} = GVWR - GVW$$

- d. The Gross Vehicle Weight must be less than or equal to the Gross Vehicle Weight Rating. If GVW exceeds GVWR, remove excess weight from vehicle before operating.

Example:

The following is for a vehicle with 68 kg (150 lb) of cargo load, a 91 kg (200 lb) operator, 100 kg (220 lb) of attachments. Attachments include a heavy-duty brush guard, poly roof, cargo box power lift kit; towing a trailer with 23 kg (50 lb) of tongue weight.

Find the correct specifications for your machine model in the SPECIFICATIONS section in this manual. To determine your machine capacity, use those numbers.

Key	Description
(A) Operator Weight:	91 kg (200 lb)
(B) Empty Vehicle Weight:	553 kg (1220 lb)
(C) Trailer Tongue Weight:	23 kg (50 lb)
(D) Cargo Load:	68 kg (150 lb)
(E) Attachments and/or Options:	100 kg (220 lb)

$$GVW = 835 \text{ kg (1840 lb)}$$

$$= 91 \text{ kg (200 lb)} + 553 \text{ kg (1220 lb)} + 23 \text{ kg (50 lb)} + 68 \text{ kg (150 lb)} + 100 \text{ kg (220 lb)}$$

$$\text{Vehicle Load Capacity} = 81 \text{ kg (180 lb)}$$

$$= \text{GWR } 916 \text{ kg (2020 lb)} \text{ less } GVW \text{ } 835 \text{ kg (1840 lb)}$$

Utilize the remaining vehicle load capacity of 81 kg (180 lb) to haul an additional passenger (or passengers), cargo, trailer tongue, and attachment weight.

OUMX068.0000E69-19-26OCT15

Loading the Cargo Box

CAUTION: The utility vehicle may become unstable if the cargo box is loaded incorrectly. Avoid loose and shifting loads or uneven loading of material.

- Do not load above height of cargo box.
- Securely anchor all loads in cargo box.
- Do not load beyond maximum capacity.

See capacities in SPECIFICATIONS.

Operating

Reduce load by half when operating over rough, hilly, or steep terrain. Do not overload machine. Limit loads to those that can be safely controlled.

Use low range, reduce speed and exercise extreme caution when operating over rough, hilly, or steep terrain.

Securely anchor and evenly distribute loads in cargo box, when loading objects into machine. Shifting loads will affect stability.

Do not load above height of cargo box.

Avoid concentrated loads at rear or side of cargo box to prevent machine from tipping over. Be sure load is evenly distributed.

Because there is a big difference in weight between dry and wet sand, the only way of getting true weight of the load you are carrying is by using a scale.

Printed weight is normally on bagged and other material.

KL66860,00000C6-19-13SEP16

Emptying Cargo Box

CAUTION: Raising a loaded cargo box changes the center of gravity. Keep vehicle a safe distance from the edge of ravine or drop-off when raising cargo box to empty.

A loaded cargo box can be very heavy. Do not attempt to manually raise a loaded cargo box. Unload cargo box before raising it by hand.

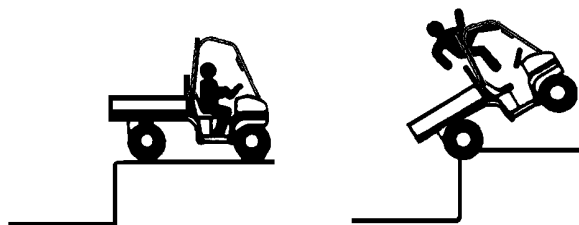

MXAL43175—UN—19MAR13

1. Back up machine to dump site.
2. Park the machine safely. (See Parking Safely in SAFETY.)
3. Open tailgate.
4. Raise cargo box to dump load.
5. Lower cargo box when empty.
6. Close tailgate. Do not drive machine with cargo box in raised position.

BB87125,0000D6D-19-14MAY13

Towing Loads

CAUTION: Avoid injury! Excessive towed load can cause loss of traction and loss of control on slopes. Stopping distance increases with speed and weight of towed load.

Do not tow a load that exceeds the maximum allowable towing load for this vehicle, as specified in this operator's manual.

Secure towed loads before transporting.

- When operating over rough, hilly, or steep terrain and reducing cargo load by half, any towed load should also be reduced accordingly.
- Use low range, reduce speed and exercise extreme caution when operating over rough, hilly, or steep terrain.
- Do not tow a load that exceeds towing capacity listed in SPECIFICATIONS.
- Do not exceed trailer tongue weight listed in SPECIFICATIONS. (The tongue load of a trailer should be approximately 10% of the total trailer weight.)
- Tow load at a speed slow enough to maintain control.

IMPORTANT: Avoid damage! When operating on terrain with extreme angles, use a ball type hitch (A).

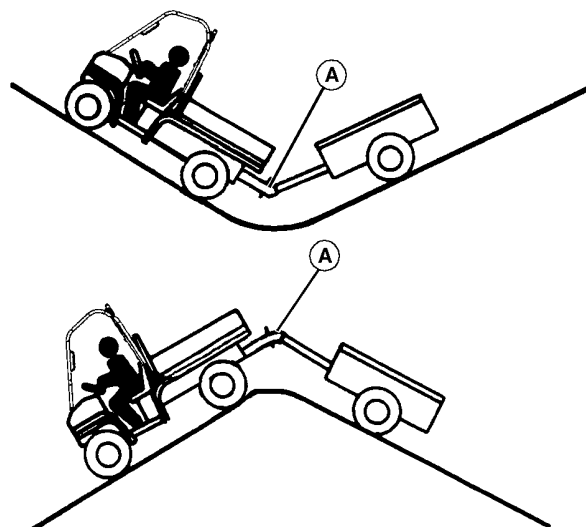

MXAL44186—UN—10APR13

- Always use approved hitch and hitch point provided for the utility vehicle. Do NOT modify the hitch or hitch point in any way.

Operating

Capacity Label



MXT007935—UN—18JUL13

Labels shown are for reference only. Confirm capacities on labels on your machine.

Your machine may have a hitch capacity label installed near the hitch area. The label indicates vertical and horizontal load capacities.

The vertical load capacity is the maximum down force which can be applied for safe operation. The horizontal load capacity is the total weight of what is being towed which must not be exceeded for safe operation.

KL66860,00000C7-19-13SEP16

Using Correct Tires and Inflation

CAUTION: Help prevent severe bodily injury or death, failure to observe these recommendations may result in loss of stability and operator control.

See tire descriptions and inflation pressures in SPECIFICATIONS.

Tires

Use of John Deere approved original equipment or optional equipment is recommended. To ensure maximum machine performance and ride quality, do not mix size, type, or placement of tires. Failure to place tires per the guidelines could result in reduced machine performance, diminished traction and poor handling.

Inflation

CAUTION: Explosive separation of tire and rim parts is possible when they are serviced incorrectly:

- Do not attempt to mount a tire without the proper equipment and experience to perform the job.

- Do not inflate the tires above the recommended pressure.
- Do not weld or heat a wheel and tire assembly. Heat can cause an increase in air pressure resulting in an explosion. Welding can structurally weaken or deform the wheel.
- Do not stand in front or over the tire assembly when inflating. Use a clip-on chuck and extension hose long enough to allow you to stand to one side.

IMPORTANT: Over inflation may damage tires and diminish ride quality. Under inflation could cause wheel damage when riding over rough terrain.

An accurate low pressure gauge is available at your John Deere dealer.

BB87125,0000D6F-19-14MAY13

Tire Chains

IMPORTANT: Tire chains are not approved for use on this vehicle.

BB87125,0000D70-19-19APR13

Transporting Machine

Towing the Machine

IMPORTANT: Avoid damage! Never tow the vehicle above 40 km/h (25 mph). Towing a vehicle at speeds above 40 km/h (25 mph) results in transaxle damage.

To avoid damage, haul the vehicle in an enclosed trailer. If an open trailer must be used, haul on a heavy-duty trailer or on a full-size truck. Be cautious and travel at reduced speeds.

Optional accessories, such as a windshield, must be removed to avoid sudden unintentional separation from the vehicle.

Never use a car type dolly with the front wheels on the dolly.

1. Check to be sure that the ignition key switch is in the STOP position.
2. Unlock the park brake and move the transaxle shift lever to the neutral (N) position for towing.
3. Move the four-wheel drive control to Disengaged/Off position.

Operating

Machine Tie Down Locations

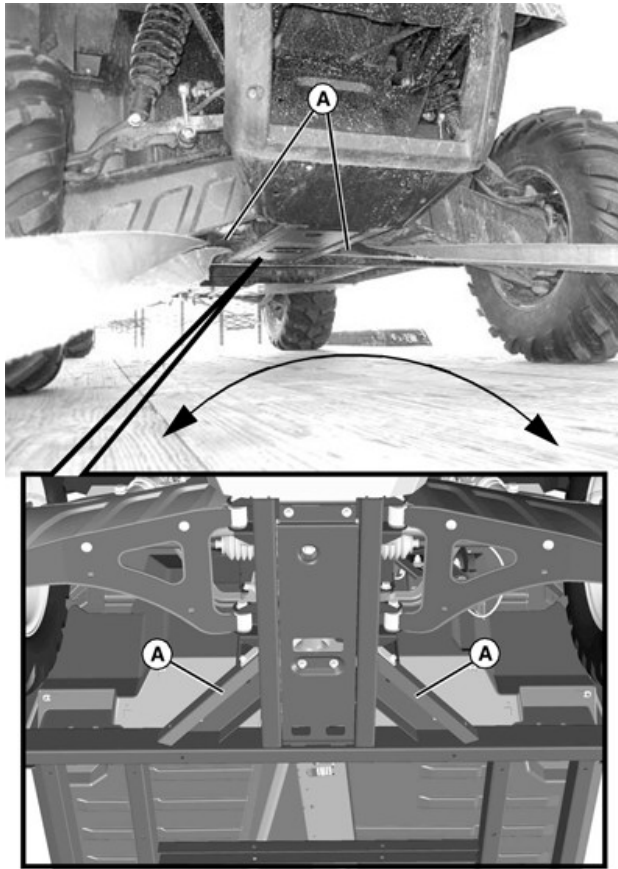

MXAL47318—UN—16APR13

Fasten front of machine around frame braces (A) to trailer with a heavy-duty strap, chain, or cable. Strap must be directed down and outward from machine.

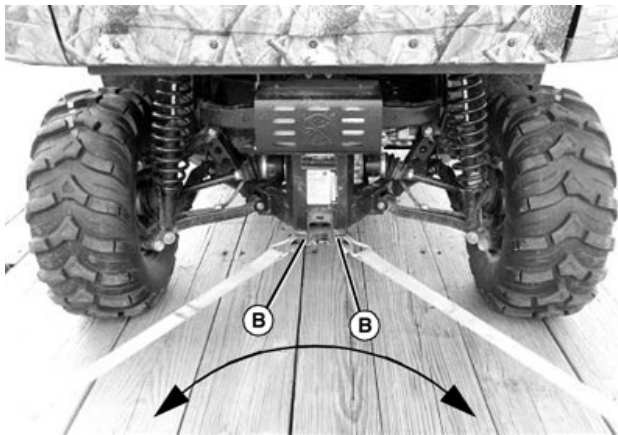

MXAL47319—UN—16APR13

Fasten rear of machine through tie-down points (B) to trailer with a heavy-duty strap, chain, or cable. Strap must be directed down and outward from machine.

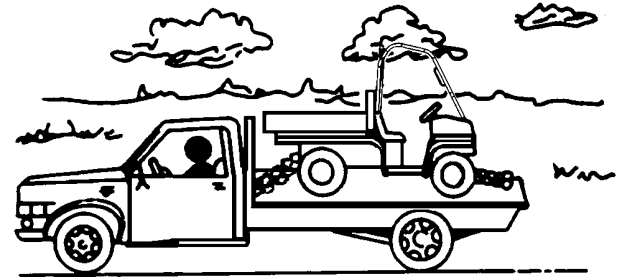
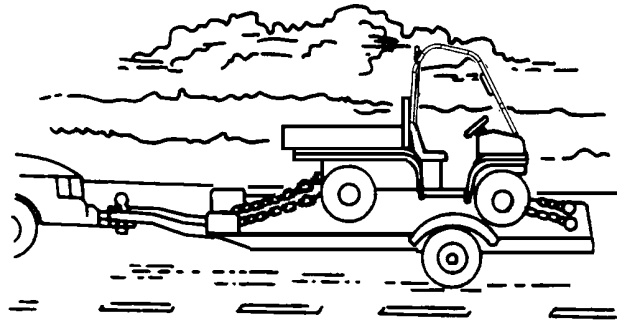

MXAL43179—UN—19MAR13

1. Back machine onto the trailer or truck.
2. Leave transaxle shift lever in Forward or Reverse gear.
3. Park the machine safely. (See Parking Safely in SAFETY.)
4. Fasten machine to trailer or truck with straps, chains, or cables.
5. Equip the trailer or truck with all the necessary lights and signs required by local, state, provincial, or federal laws.
6. Remove or secure optional attachments, if equipped.

OUMX068,0000918-19-26OCT15

Hauling the Machine

NOTE: Space limitations can vary from one truck manufacturer to another. Short bed trucks do not have the necessary length requirement to accommodate the machine.

Optional Attachments & Kits

Attachments and Kits

NOTE: All attachments and kits are not shown. Attachments and kits vary by machine model and may not be available in all regions. Specifications and design are subject to change without notice. See your John Deere dealer for availability in your region.

MX00654.00000E3-19-04SEP13

Using Quick Clamps

Most optional attachments and kits use quick clamps to attach to the machine.

Using Clamps

1. Check and adjust the tightness of the clamps after the first 30 days of use.
2. If clamps are loose:



MXAL44361—UN—28MAR13

- a. Open clamp arm lever (A).
 - b. Increase tension by turning lever (A) one full turn clockwise. Repeat as needed.
 - c. Lock clamps.
3. If clamps are tight:
 - a. Open clamp arm lever (A).
 - b. Decrease tension by turning lever (A) one full turn counter-clockwise. Repeat as needed.
 - c. Lock all clamps.

BB87125.0000D72-19-19APR13

Light Kits

Adjusting Lights

1. Adjust light direction:



MXAL47322—UN—16APR13

- Type A - Loosen locknut (A) on carriage bolt and direct light where needed. Tighten locknut to secure in position.

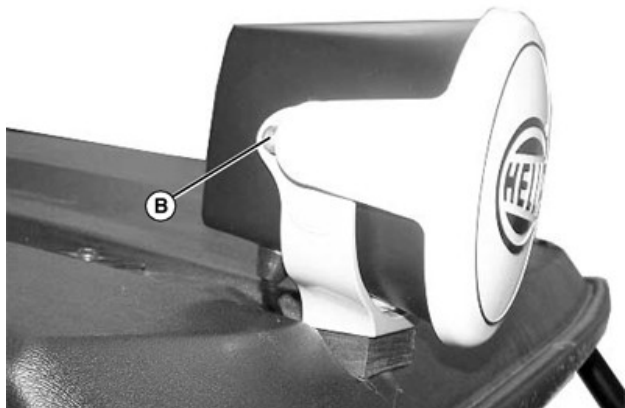

MXAL47323—UN—16APR13

- Type B - Loosen two hex head bolts (B) on light and direct light where needed. Tighten both hex head bolts to secure in position.

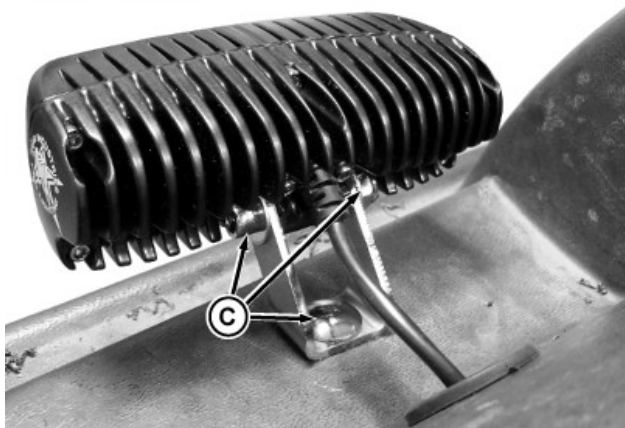

MXT016177—UN—28OCT15

- LED Lights - Loosen hardware (C) and direct light where needed. Tighten hardware to secure in position.

Replacing Fuses

Most light kits have a replaceable fuse located on the

Optional Attachments & Kits

wiring harness near the Protective Structure switch bank.

OUMX068,0000E98-19-06NOV15

Backup Alarm

Periodically Check Alarm Function

1. Start machine.
2. Move transaxle shift lever into Reverse gear and listen for alarm.
3. Contact your John Deere dealer if alarm does not function properly.

BB87125,0000D74-19-19APR13

Horn

Horn Switch Location

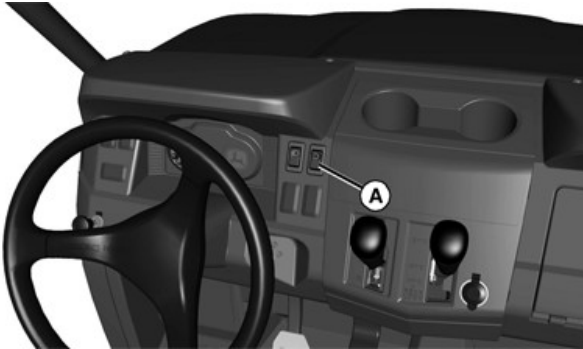

MXAL47325—UN—16APR13

1. Press switch (A) to activate horn. Release switch to deactivate.

BB87125,0000D75-19-19APR13

Canvas Cab

Opening Rear Panel

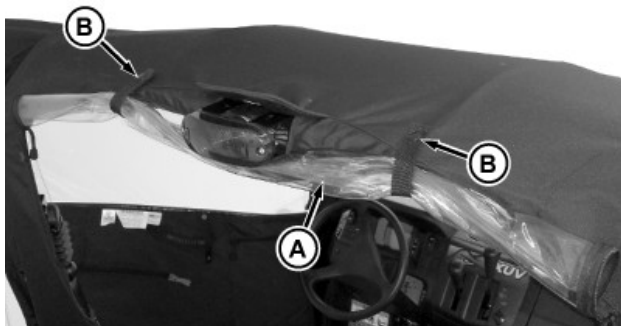

MXT016157—UN—21OCT15

1. Unzip plastic window (A).

2. Roll window up, wrap straps (B) around window, and snap into position as shown.

Using Transport Strap

To avoid damage to doors, use the transport strap when towing the machine on a trailer.

1. Open the rear panel.
2. Close cab doors.



MXT016175—UN—28OCT15

3. Reach through the open rear panel to attach the transport strap (A) to one of the doors.
4. Route transport strap to attach to the other door.

Servicing Rear Panel

Snaps and zipper on the rear panel can be lubricated as needed with commercially available products.

OUMX068,0000E99-19-06NOV15

Protective Structure Rear Screen

Adjusting Headrest Position

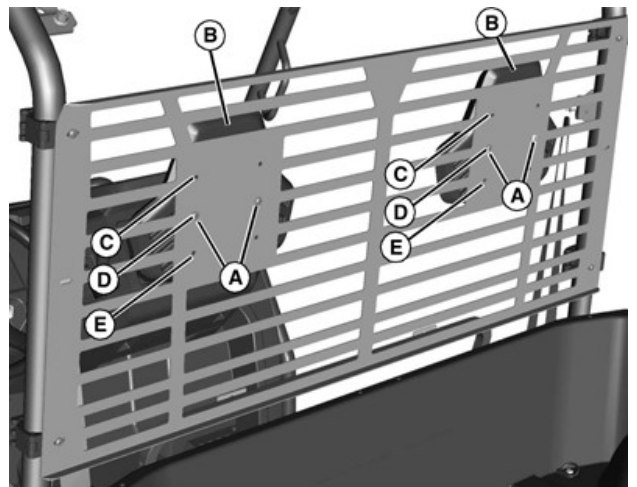

MXAL47328—UN—16APR13

Headrest shown in center position.

1. Remove two screws (A) and move each headrest (B)

Optional Attachments & Kits

to either top (C), center (D) or bottom (E) position.
Secure with two screws.

OUMX068,0000E6A-19-26OCT15

Front Receiver Hitch

Using Hitch

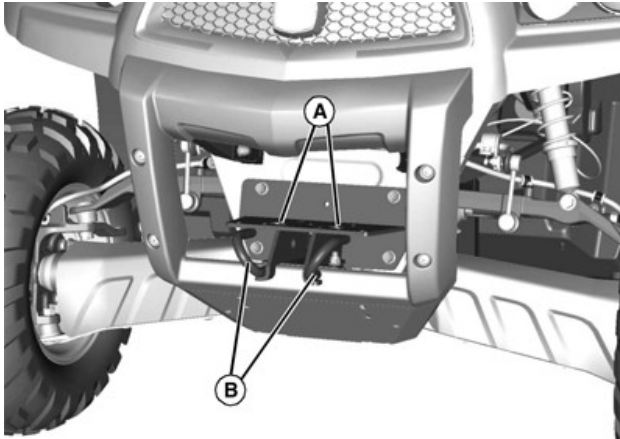

MXAL47329—UN—16APR13

1. Mount front accessories into holes (A) in front receiver hitch.
2. Use rings (B) as needed.

BB87125,0000D78-19-19APR13

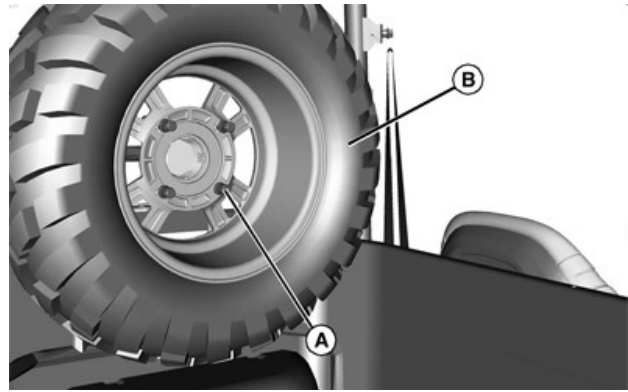

MXAL47332—UN—16APR13

2. Install tire (B) as shown (facing outward same as tires on machine) on four lug bolts (A) and secure with lug nuts.

OOU2005,0000187-19-05SEP13

Tire Rack

Using Tire Rack



MXT008882—UN—05SEP13

1. Remove four lug nuts from four lug bolts (A).

Service Intervals

Servicing Your Machine

IMPORTANT: Avoid damage! High-pressure washing can cause damage to machine components.

Operating in extreme conditions may require more frequent service intervals:

- Engine components may become dirty or plugged when operating in extreme heat, dust, or other severe conditions.
- Engine oil can degrade if machine is operated constantly at slow or low engine speeds or for frequent short periods of time.

Please use the following timetables to perform routine maintenance on your machine.

Park the vehicle safely. (See Park Safely in the SAFETY Section.)

OUMX068,000052F-19-20JUN15

Break In

After First 8 Hours:

- Change engine oil and filter.
- Check and tighten wheel bolts to correct torque.
- Check brake fluid level.

After First 100 Hours:

- Adjust engine valve clearance. (See your John Deere dealer for this service.)

OUMX068,0000A9F-19-19NOV14

Every 50 Hours or Annually

- Check brake fluid level and brake line connections.
- Lubricate drive line.
- Check 4WD front differential oil level.
- Check transaxle oil level.
- Inspect driveline CV boots for tears or punctures.
- Inspect park brake for proper function. (See your John Deere dealer for any adjustments needed.)
- Inspect differential lock engagement. (See your John Deere dealer for any adjustments needed.)
- Grease cargo box tailgate strikers.
- Grease rear control arm.

OUMX068,00012D3-19-13JUN17

Every 100 Hours or Annually (whichever comes first)

- Change engine oil and filter.

OUMX068,0000AA0-19-19NOV14

Every 200 Hours or Annually (whichever comes first)

- Change fuel filter.
- Change spark plugs.
- Change air cleaner element.
- Clean dust unloading valve.
- Check drive belt condition.
- Clean primary drive clutch/fan.
- Inspect battery. Clean if necessary.
- Check toe-in.
- Check brake pad wear.
- Check and tighten wheel bolts to correct torque.
- Check/clean spark arrestor if equipped.
- Check and tighten all hardware.
- Inspect cargo box lanyards.
- Check shift cable adjustment/tension.
- Adjust engine valve clearance. (See your John Deere dealer for this service.)

OUMX068,0000E9A-19-28OCT15

Every 400 Hours or 24 Months (whichever comes first)

- Inspect suspension bushings for play. (See your John Deere dealer for this service.)
- Inspect wheel bearings for play. (See your John Deere dealer for this service.)

BB87125,0000D83-19-19APR13

Every 800 Hours or 24 Months (whichever comes first)

- Change transaxle oil.
- Change 4WD front differential oil.
- Replace drive belt.

BB87125,0000D84-19-19APR13

Every 1000 Hours or 24 Months (whichever comes first)

- Flush and refill brake fluid. (See your John Deere dealer for this service.)

Service Intervals

- Inspect shocks and struts for leaks.

BB87125.0000D85-19-19APR13

Service Lubrication

Grease

IMPORTANT: Avoid Damage! Use recommended John Deere greases to avoid component failure and premature wear.

The following grease is recommended for service:

- John Deere Multi-Purpose HD Lithium Complex Grease
- Grease-Gard™ Premium Plus

Not all grease types are compatible; John Deere does not recommend mixing greases. If using any product other than the recommended grease in service, purge any remaining grease from the system prior to application. If this is not practical, grease twice as often until all old grease is purged from the system.

OUMX068,0000642-19-27AUG14

Lubricating Drive Line

1. Park the machine safely. (See Parking Safely in SAFETY.)

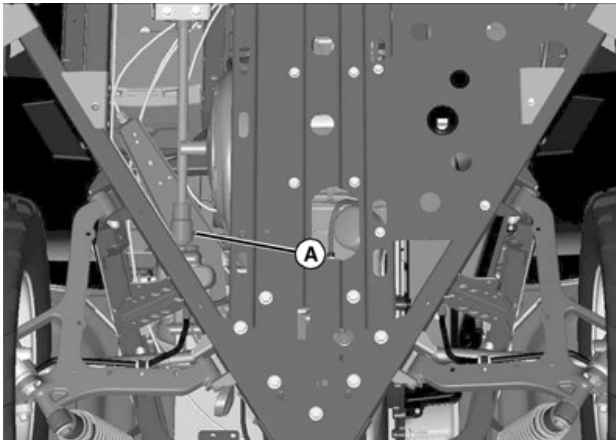

MXAL47333—UN—16APR13

Viewed from under the machine.

2. Lubricate grease fitting (A) on rear drive line with one or two shots of grease.

BB87125,0000D87-19-19APR13

Lubricating Suspension

1. Park the machine safely. (See Parking Safely in SAFETY.)



MXAL47334—UN—16APR13

2. Using a grease gun, apply grease to rear control arm through the grease fittings (A) until grease is visible at joint interface (B).
3. Repeat on opposite side of machine.
4. Remove exposed grease from joint.

BB87125,0000D88-19-26OCT15

Service Engine

Emissions Service Information

A qualified repair shop or person of the owner's choosing may maintain, replace, or repair emission control devices and systems with original or equivalent replacement parts. However, warranty, recall and all other services paid for by John Deere must be performed at an authorized John Deere service center.

Within the warranty period, John Deere will reimburse reasonable service costs incurred at service providers outside the John Deere authorized network only in an unsafe, emergency condition if an authorized John Deere dealer is not available and the failure does not arise from the owner's misuse or failure to perform required maintenance. An emergency situation exists under this section if, after 30 days, the authorized John Deere network is unable to perform the repairs or source replacement parts.

Emission Control System Certification Label

NOTE: Tampering with emission controls and components by unauthorized personnel may result in severe fines or penalties. Emission controls and components can only be adjusted by EPA and/or CARB authorized service centers. Contact your John Deere Retailer concerning emission controls and component questions.

The presence of an emissions label signifies that the engine has been certified with the United States Environmental Protection Agency (EPA) and/or California Air Resources Board (CARB).

The emissions warranty applies only to those engines marketed by John Deere that have been certified by the EPA and/or CARB; and used in the United States and Canada in off-road mobile equipment.

Altitude Adjustment (Gasoline or Propane Converted Engines Only)

If your engine features a carburetor it is calibrated by the engine manufacturer and is not adjustable.

If your engine is operated at altitudes below 610 m (2,000 ft.), a high altitude carburetor jet kit is not required. If your engine is operated at altitudes above 610 m (2,000 ft.), a high altitude carburetor jet kit may be required for proper engine performance and emissions control. Operating the engine with the wrong carburetor configuration at a given altitude may increase the engine's emissions and decrease fuel efficiency and performance.

See a qualified service provider for details on jet kit requirements for your specific product.

TC00531,00000EC-19-28MAR16

Avoid Fumes

CAUTION: Engine exhaust fumes contain carbon monoxide and can cause serious illness or death.

- Move the machine to an outside area before running the engine.
- Do not run an engine in an enclosed area without adequate ventilation.
- Connect a pipe extension to the engine exhaust pipe to direct the exhaust fumes out of the area.
- Allow fresh outside air into the work area to clear the exhaust fumes out.

BB87125.0000D8A-19-14MAY13

Gasoline Engine Oil

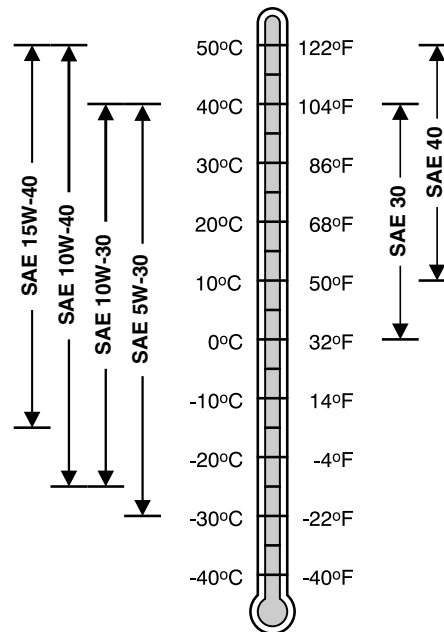

TS1734—UN—04SEP13

Oil Viscosities for Air Temperature Ranges

Use oil viscosity based on the expected air temperature range during the period between oil changes.

Using single viscosity grade oils such as SAE 30 or SAE 40 can reduce oil consumption in air cooled engines.

John Deere Turf-Gard™ is preferred.

The following oils are also recommended:

Turf-Gard is a trademark of Deere & Company

Service Engine

- John Deere Plus-4™
- John Deere Plus-50™ II

Other oils may be used if they meet one or more of the following:

- ILSAC GF-5
- API Service Category SN
- API Service Category SM
- API Service Category SL
- API Service Category SJ
- ACEA Oil Sequence A5
- ACEA Oil Sequence A3
- ACEA Oil Sequence A1
- ACEA Oil Sequence C4
- ACEA Oil Sequence C3
- ACEA Oil Sequence C2
- ACEA Oil Sequence C1

DX,ENOIL2-19-20JUL15

Checking Engine Oil Level

IMPORTANT: Avoid damage! Failure to check the oil level regularly could lead to serious engine problems if oil level is out of the operating range:

- Check oil level before operating.
- Check oil level when the engine is cold and not running.
- Keep oil level between the dipstick marks.
- Shut off engine before adding oil.

1. Park the machine safely. (See Parking Safely in SAFETY.)
2. To gain access to oil fill cap, remove access cover.

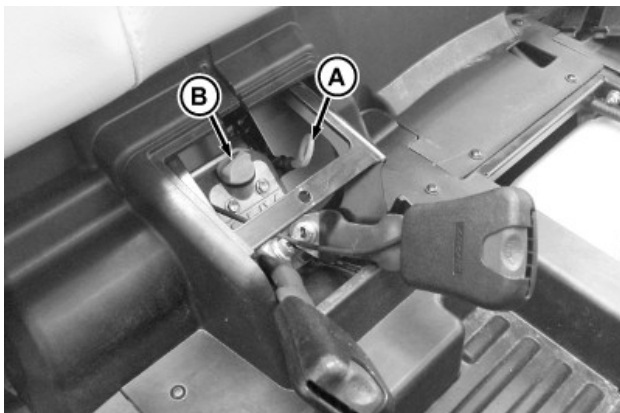

MXT016171—UN—26OCT15

3. Remove dipstick (A) and wipe it clean.
4. Install dipstick.

*Plus-4 is a trademark of Deere & Company
Plus-50 is a trademark of Deere & Company*

5. Remove dipstick.
6. Check oil level:
 - Oil level must be between hatch marks on dipstick.
 - If oil level is low, remove cap (B) and add oil to bring oil level no higher than upper mark on dipstick.
 - If oil level is above upper mark, drain to proper level. Determine cause of this condition and correct.
7. Install dipstick.
8. Install the access cover.

OUMX068,0000E6B-19-06NOV15

Changing Engine Oil and Filter

IMPORTANT: Avoid damage! Change the oil more often if the vehicle is used in extreme conditions:

- Dusty conditions.
- Frequent slow or low-speed operation.
- Frequent short trips.

1. To warm the oil, run engine.
2. Park the machine safely. (See Parking Safely in SAFETY.)

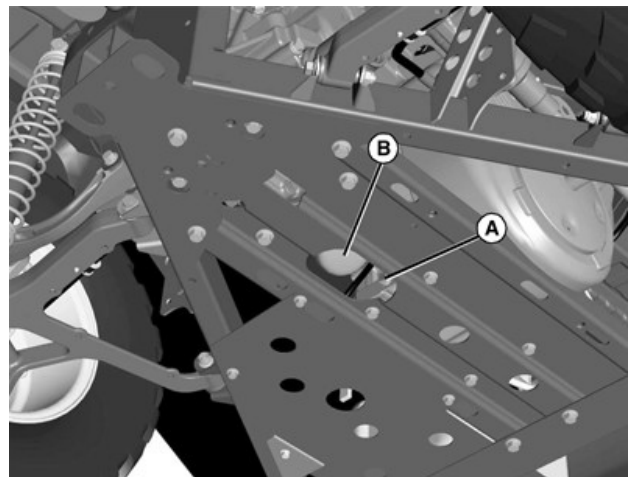

MXAL47337—UN—16APR13

Service Engine

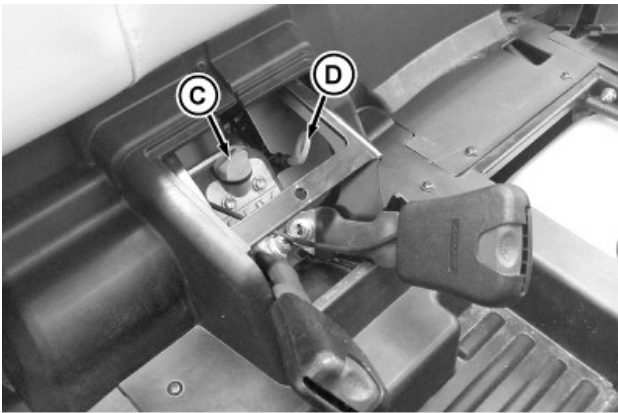

MXT016172—UN—26OCT15

3. Place drain pan under engine drain plug (A) and oil filter (B).
4. To gain access to oil fill cap, remove access cover.
5. Remove oil fill cap (C) from filler opening.
6. Remove drain plug (A) and drain oil into oil drain pan. Allow oil to drain completely. Place oil fill cap (C) back on filler opening.
7. Remove and discard oil filter (B) on engine. Wipe off filter base on engine.
8. Put a light coat of clean engine oil on gasket of new oil filter.
9. Install new filter until rubber gasket contacts filter base. Tighten filter an additional one-half turn.
10. Install drain plug and tighten to specifications.

Specification

Engine Oil Drain Plug—Torque. 13.6 N·m (10 lb·ft)

11. Remove oil fill cap (C) from filler opening.

IMPORTANT: Avoid damage! Do not overfill crankcase with oil. Oil capacities given are with engine and crankcase dry. Some oil will remain in engine after draining.

12. Add recommended fluid no higher than upper mark on dipstick (D). Do not overfill.
13. Install oil fill cap.
14. Start and run engine at idle to check for leaks. Stop engine. Fix any leaks before operating.
15. Check oil level, add oil if necessary.
16. Install access cover.

OUMX068,0000E6C-19-06NOV15

Servicing Air Intake

1. Park the machine safely. (See Parking Safely in SAFETY.)

Checking and Cleaning Air Intake

1. Allow engine to cool.
2. Tilt seats forward.
3. Raise and secure cargo box with latch support.

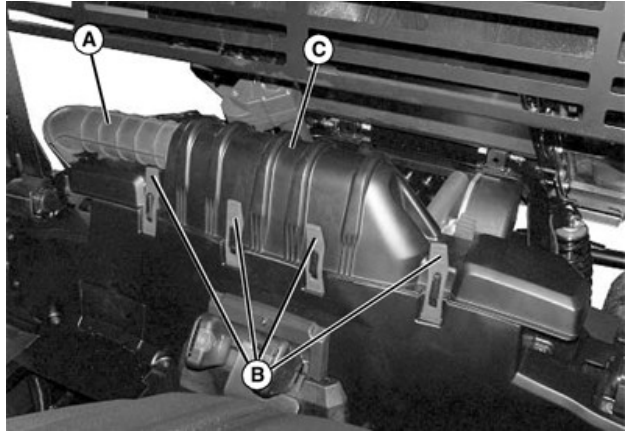

MXAL47339—UN—16APR13

4. Check intake hose (A) for damage or cracking. Replace if necessary.
5. Remove four rubber latch straps (B) on each side of cover (C). Remove cover (C).

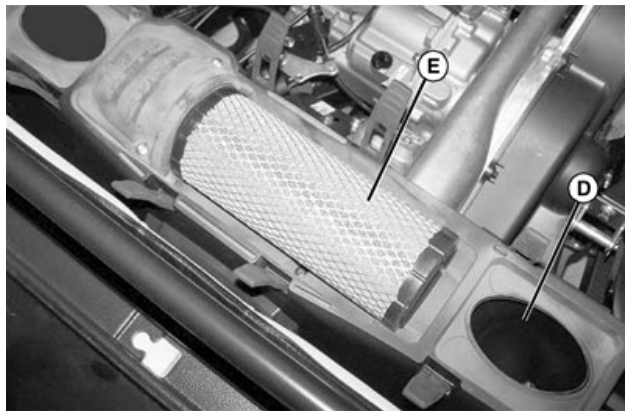

MXAL47340—UN—16APR13

6. Clean any debris from inlet (D).
7. Check foam cleaner (E) for dirt or debris. Clean and dry completely and install back onto air intake.
8. Install cover (C) back onto air intake and secure with eight rubber straps.
9. Lower the cargo box.
10. Lower seats.

Servicing Air Cleaner Element

IMPORTANT: Avoid damage! Dirt and debris can enter engine when air cleaner canister is opened. Do not open canister unless required for scheduled service, keeping contamination of the intake system to a minimum.

Check filter element more frequently if operating in dusty conditions.

Service Engine

1. Allow engine to cool.
2. Tilt seats forward.
3. Raise and secure cargo box with latch support.

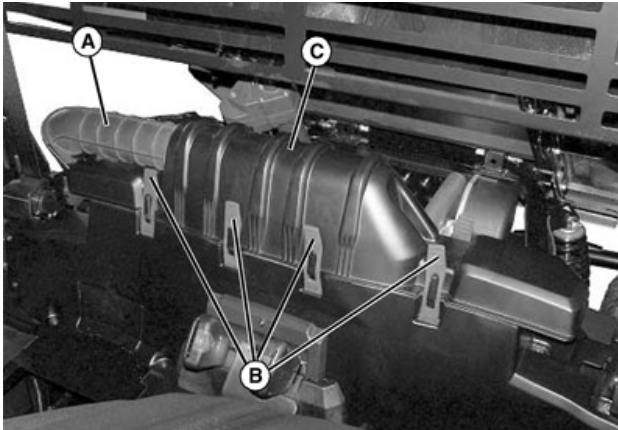

MXAL47341—UN—16APR13

4. Check intake hose (A) for damage or cracking. Replace if necessary.
5. Remove four rubber latch straps (B) on each side of cover (C). Remove cover (C).

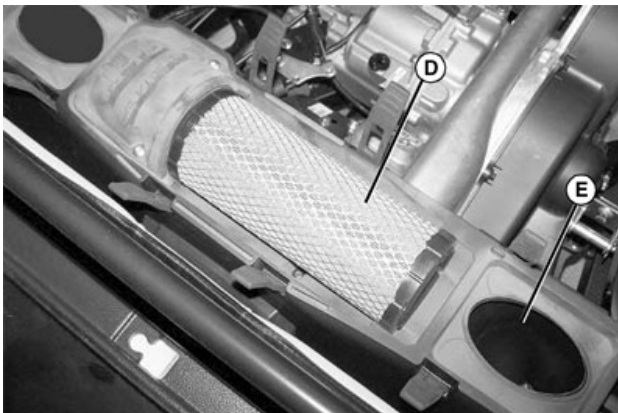

MXAL47342—UN—16APR13

6. Remove and discard filter element (D). Replace with a new filter element.
7. Clean any debris from inlet (E).
8. Clean dust unloading valve.
9. Install cover (C) back onto air intake and secure with eight rubber straps.
10. Lower the cargo box.
11. Lower seats.

Cleaning Dust Unloading Valve

IMPORTANT: Avoid damage! Do not operate engine without air cleaner element and rubber dust unloading valve installed.

1. Allow engine to cool.
2. Raise and secure cargo box with latch support.

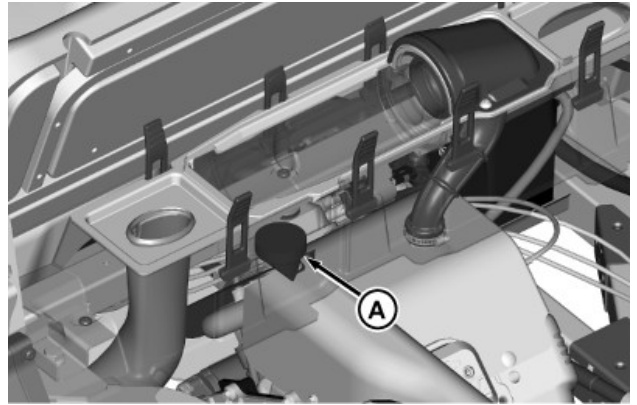

MXT016178—UN—28OCT15

3. Squeeze dust unloading valve (A) to clean.
4. Remove and replace if damaged.
5. Lower the cargo box.

OUMX068,0000E9B-19-28OCT15

Cleaning the Engine

1. Park the machine safely. (See Parking Safely in SAFETY.)

Severe Duty Service

If engine has been operated in severe conditions, more frequent engine maintenance is required.

NOTE: Severe Duty Conditions:

- Operating vehicle in dusty and/or muddy conditions - May result in plugged cooling fins. Inspect and/or clean engine-cooling system. See Cooling System Inspection and Cleaning.
- Immersion in water - May result in water contaminating the oil. Inspect and/or change oil as required.
- Extended engine idling - May result in spark plug fouling. Inspect and/or clean plugs as required.
- Short trip cold weather operation - May result in spark plug fouling. Inspect and/or clean plugs as required.

Cooling System Inspection and Cleaning

NOTE: This is an air-cooled engine. Dirt, debris and mud can restrict cooling airflow into the engine. Restriction of cooling airflow may result in severe engine damage. Inspect and/or clean engine cooling system as required.

1. Stop engine and inspect external parts of the engine for sign of debris/mud build up:

Service Engine

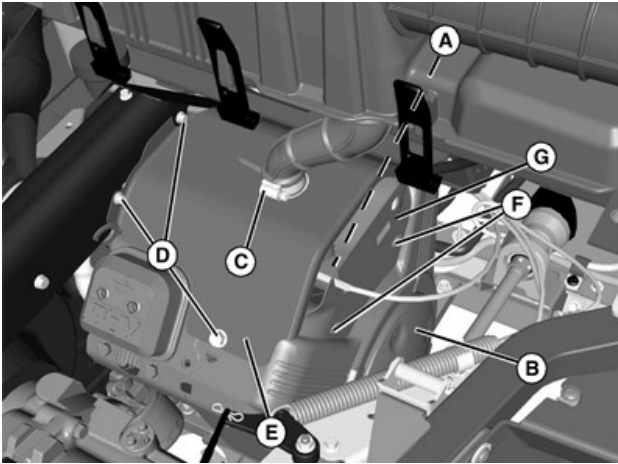

MXAL47343—UN—16APR13

Some parts removed for better view.

Checking Spark Plug

⚠ CAUTION: Avoid injury! Touching hot surfaces can burn skin. The engine, components, and fluids are hot if the engine has been running. Allow the engine to cool before servicing or working near the engine and components.

1. Park the machine safely. (See Parking Safely in SAFETY.)
2. Raise and secure cargo box with latch support.



MXAL47344—UN—16APR13

3. From under cargo box, disconnect spark plug wire (A).

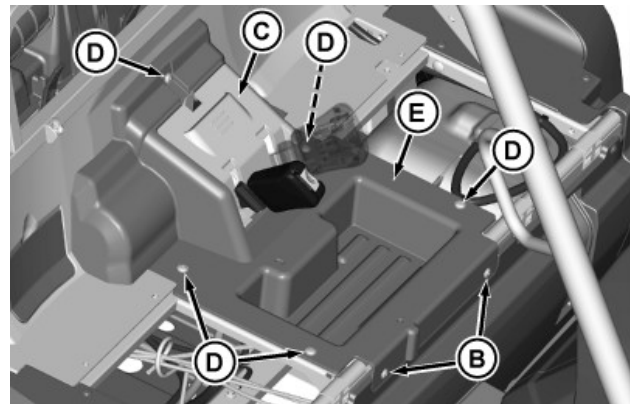

MXT016161—UN—22OCT15

Picture Note: XUV560 with bench seat. Seat removed for better view.

- Inspect the cooling fins (A) inside the blower housing thru the holes/plugs.
 - Inspect rotating screen (B) and clean as needed.
2. If signs of excessive mud or debris are apparent inside the blower housing, clean the cooling system:
 - a. Stop engine before cleaning.

IMPORTANT: Do not use water on a hot engine.

- b. Allow engine to cool approximately 20 minutes prior to cleaning with water.
- c. To access engine cooling fins, loosen and raise clamp (C), remove three bolts (D) and raise panel (E). Remove two screws (F) and panel (G).
- d. Light debris like grass and chaff build-up may be removed by compressed air and soft bristle brush.

IMPORTANT: Do not use high-pressure water from a pressure washer. High-pressure water may result in damage to gaskets, wires and other engine components.

- e. Wash mud out of cooling fin areas with low pressure water (garden hose). A soft bristle brush may also be used.
 - f. Run the engine at moderate speed and direct low pressure water into the intake screen and other openings around the blower housing until mud is flushed from the interior.
3. Install all parts before running the engine.

BB87125,0000D8F-19-14MAY13

Service Engine

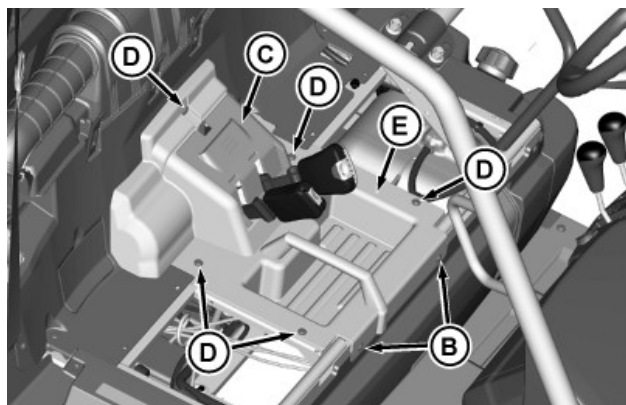

MXT016189—UN—02NOV15
Picture Note: XUV560 with bucket seats. Seats removed for better view.

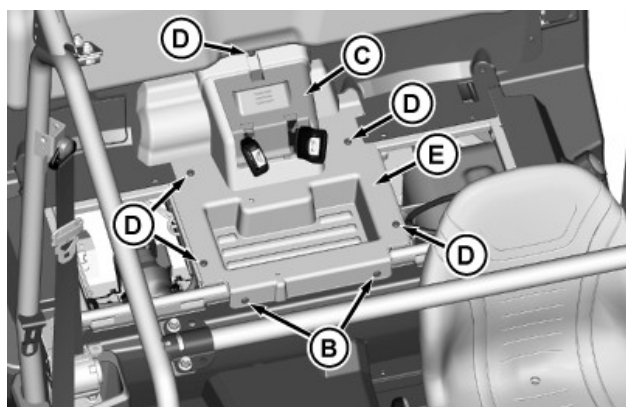

MXT016190—UN—02NOV15
Picture Note: XUV560 S4, seat removed for better view.

4. Remove two Torx head screws (B).
5. Tilt seats forward.
6. Remove access cover (C).
7. Remove five Torx head screws (D) and remove center panel (E).
8. Disconnect spark plug wire under panel.
9. Remove spark plugs using appropriate spark plug socket.
10. Inspect spark plugs for:
 - Cracked porcelain.
 - Pitted or damaged electrodes.
 - Other wear or damage.
11. Clean spark plugs carefully with a wire brush.

NOTE: In Canada, replace with resistor spark plug only.

12. Replace spark plugs if necessary.

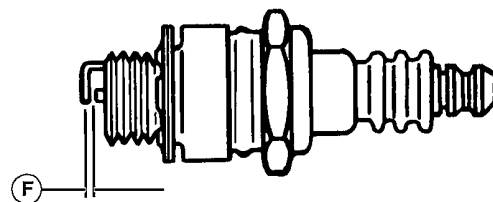

MXAL47346—UN—16APR13

13. Check and adjust spark plug gap (F):
 - See SPECIFICATIONS for gap distance.

14. Install and tighten spark plugs. Tighten to specification.

Specification

Spark Plug—Torque. 20.3 N·m (180 lb·in)

15. Install spark plug wires.
16. Install center panel with five Torx head screws.
17. Install access cover.
18. Lower seat and install two remaining Torx head screws on center panel.
19. Lower the cargo box.

OUMX068,0000E51-19-04NOV15

Replacing Fuel Filter

⚠ CAUTION: Fuel vapors are explosive and flammable:

- Do not smoke while handling fuel.
- Keep fuel away from flames or sparks.
- Shut off engine before servicing.
- Cool engine before servicing.
- Work in a well-ventilated area.
- Clean up spilled fuel immediately.

1. Park the machine safely. (See Parking Safely in SAFETY.)

Service Engine

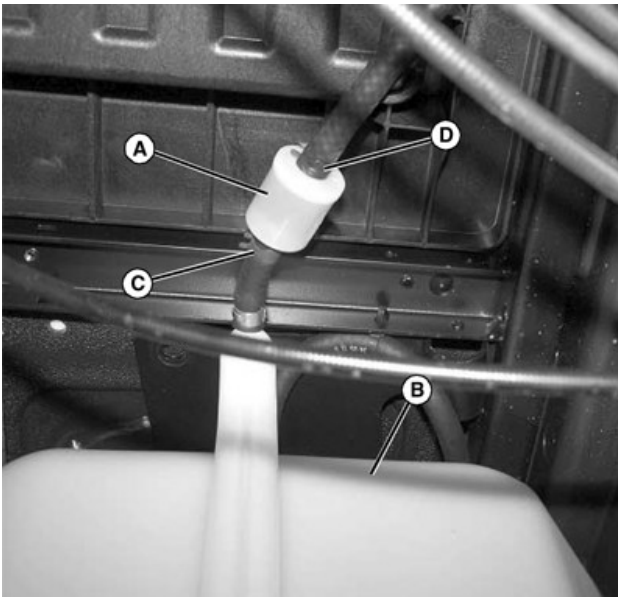

MXAL47347—UN—16APR13

2. Locate the fuel filter (A) under machine next to fuel tank (B).
3. Place a drain pan or cloth under fuel lines to catch any fuel left in lines.
4. Loosen red clamp (C) and remove fuel filter from short fuel line. Lower fuel filter toward drain pan to drain excess fuel.
5. Loosen black clamp (D) and remove fuel filter from fuel line.

IMPORTANT: Incorrect installation of fuel filter may cause engine damage. Install the filter with the arrow pointing in the direction of fuel flow (towards the engine) for proper operation.

6. Install new filter making sure filter arrow is pointed in the direction of fuel flow (towards the engine).
7. Connect hoses to filter and secure with clamps.

BB87125,0000D91-19-14MAY13

Checking Spark Arrestor

CAUTION: Touching hot surfaces can burn skin. The engine, components, and fluids will be hot if the engine has been running. Keep hands and body away from hot surfaces when servicing or working near the engine and components.

1. Park the machine safely. (See Parking Safely in SAFETY.)
2. Allow machine to cool completely.

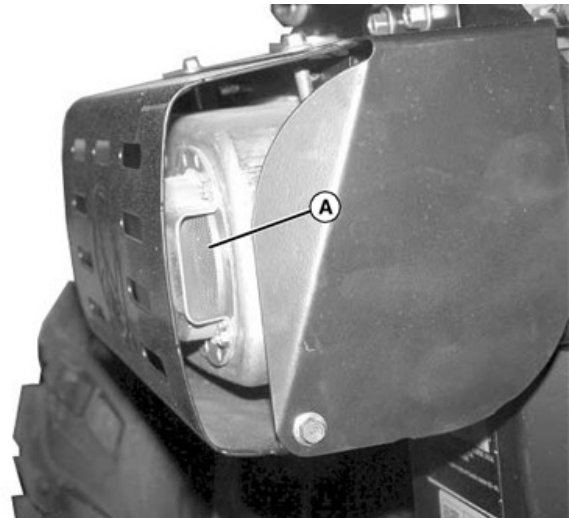

MXAL47348—UN—16APR13

3. Inspect spark arrestor (A) on muffler.
 - If spark arrestor is corroded or plugged, follow steps below to remove and clean spark arrestor.

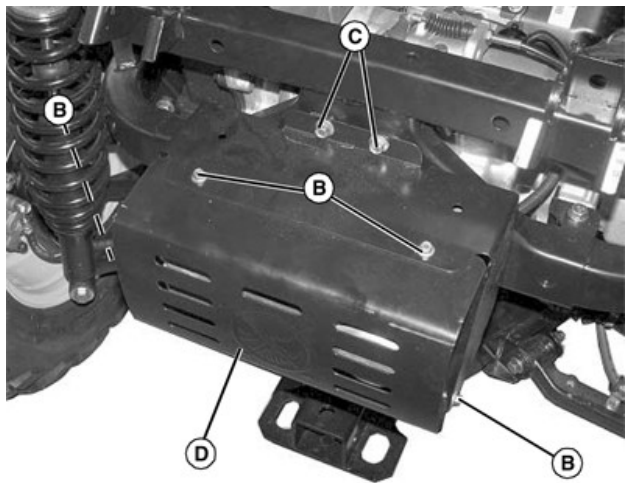

MXAL47349—UN—16APR13

4. Remove four self-tapping screws (B) and spacers and two self-tapping screws (C) and remove shield (D).

Service Engine

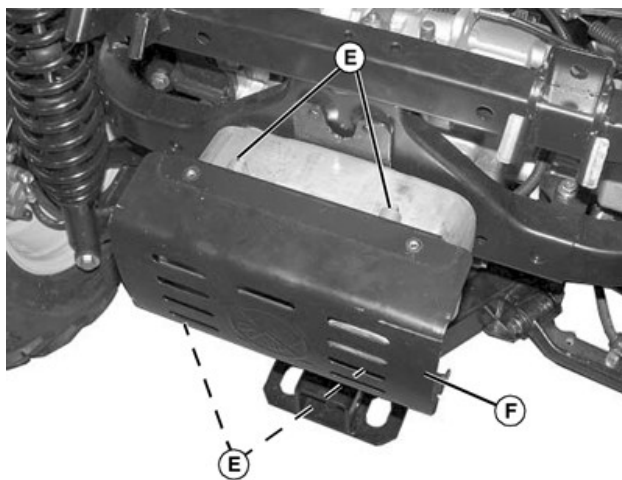

MXAL47350—UN—16APR13

5. Remove four self-tapping screws (E) and spacers and remove shield (F).

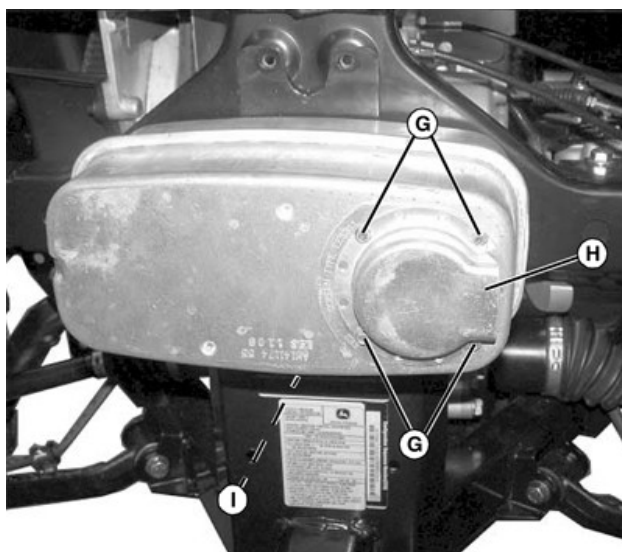

MXAL47351—UN—16APR13

6. Remove four self-tapping screws (G) and spark arrester (H) making note of direction of arrester assembly.
 - If plugged, spray with carburetor/choke cleaner and blow dry with low pressure compressed air.
 - If damaged, replace spark arrester, or remove bottom self-tapping screw (I) and replace entire muffler assembly.
7. Install spark arrester with four self-tapping screws.
8. Install remaining brackets and hardware, reverse order of removal.

BB87125,0000D92-19-19APR13

Service Transmission

Transaxle Oil

Use the appropriate oil viscosity based on these air temperature ranges. Operating outside of these recommended oil air temperature ranges may cause premature hydrostatic transmission or hydraulic system failures.

IMPORTANT: Mixing of LOW VISCOSITY HY - GARD™ and HY - GARD™ oils is permitted. DO NOT mix any other oils in this transmission. DO NOT use engine oil or “Type F” (Red) Automatic Transmission Fluid in this transmission.

John Deere J20C HY-GARD™ transmission and hydraulic oil is recommended. John Deere J20D Low Viscosity HY-GARD™ transmission and hydraulic oil may be used, if within the specified temperature range.

Other oils may be used if above recommended John Deere oils are not available, provided they meet one of the following specifications:

- John Deere Standard JDM J20C;
- John Deere Standard JDM J20D.

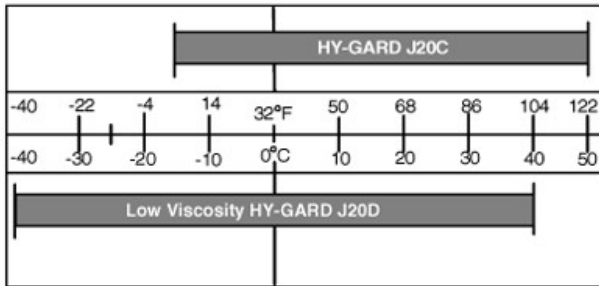

MXAL44417—UN—28MAR13
BB87125.0000D93-19-19APR13

4WD Front Differential Oil

Use the appropriate oil viscosity based on these air temperature ranges. Operating outside of these recommended oil air temperature ranges may cause premature hydrostatic transmission or hydraulic system failures.

IMPORTANT: Mixing of LOW VISCOSITY HY - GARD™ and HY - GARD™ oils is permitted. DO NOT mix any other oils in this transmission. DO NOT use engine oil or “Type F” (Red) Automatic Transmission Fluid in this transmission.

John Deere J20D Low Viscosity HY-GARD™ transmission and hydraulic oil is recommended.

Other oils may be used if above recommended John Deere oils are not available, provided they meet the following specifications:

- John Deere Standard JDM J20D.

BB87125.0000D94-19-19APR13

Checking 4WD Front Differential Oil Level

1. Park the machine safely. (See Parking Safely in SAFETY.)
2. Allow machine to cool down for at least one hour.

IMPORTANT: Dirt and debris in oil may cause damage to the 4WD differential. Clean area around opening before removing plug.

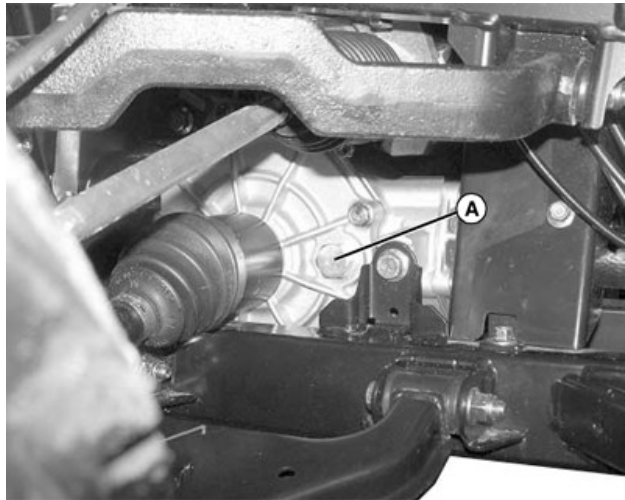

MXAL47353—UN—16APR13

Fill plug under left front side.

3. Remove fill plug (A) located on left side of 4WD front differential.
4. Oil should be level with the bottom of the fill port. If oil level is low:
 - a. Add oil through fill port until level is correct.
 - b. Install and tighten fill plug to specification.

Specification

Front Differential Fill
Plug—Torque. 45-54 N·m (33-40 lb-ft)

BB87125.0000D95-19-14MAY13

Changing 4WD Front Differential Oil

1. Operate machine to warm 4WD front differential oil.
2. Park the machine safely. (See Parking Safely in SAFETY.)

IMPORTANT: Dirt and debris in oil may cause damage to the 4WD differential. Clean area around opening before removing plug.

Service Transmission

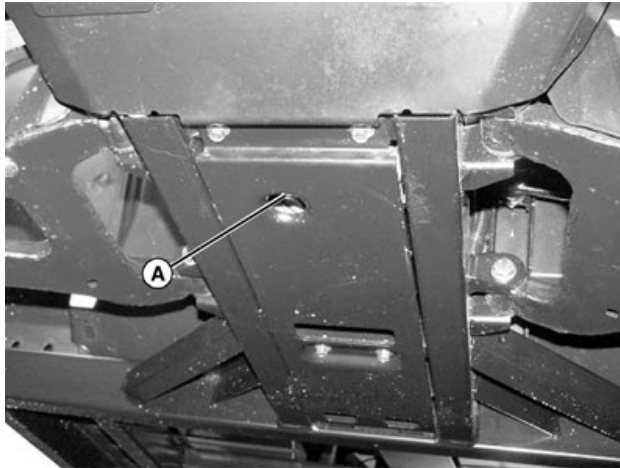

MXAL47354—UN—16APR13

Drain plug under center of machine.

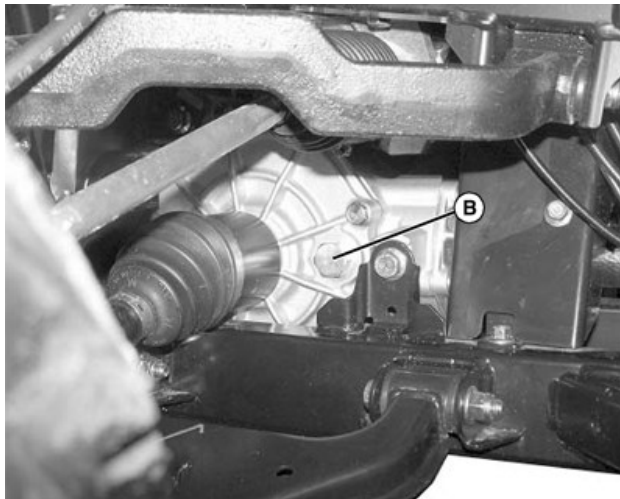

MXAL47355—UN—16APR13

Fill plug under left front side.

3. Position drain pan under 4WD front differential drain plug (A) at bottom right of housing.
4. Remove fill plug (B) located on left side of 4WD front differential.
5. Remove 4WD front differential drain plug (A) and allow oil to drain through opening in frame and into drain pan.
6. Check washer on drain plug. Replace if missing or in poor condition.
7. Install and tighten drain plug to specification after all oil has drained.

Specification

Front Differential Drain Plug—Torque. 30-35 N·m (22-26 lb-ft)

8. Add oil until the level is even with the bottom of the fill port.
9. Install and tighten fill plug to specification.

Specification

Front Differential Fill Plug—Torque. 45-54 N·m (33-40 lb-ft)

10. Check 4WD front differential oil level again after the first several hours of operation.

BB87125,0000D96-19-14MAY13

Checking Transaxle Oil Level

IMPORTANT: Hot hydraulic oil will expand and show incorrect oil level. Check oil level:

- When oil is cold.
- With engine not running.

1. Park the machine safely. (See Parking Safely in SAFETY.)
2. Raise and secure cargo box with latch support.

IMPORTANT: Dirt and debris in oil may cause damage to the transaxle. Clean area around opening before removing dipstick.



MXAL47356—UN—16APR13

3. Remove dipstick (A) located on the top of the transaxle housing. Wipe dipstick clean.
4. Check oil level by setting dipstick on threads in transaxle case, then removing and checking oil level.
5. Add oil as needed through the dipstick fill hole.
6. Install and tighten dipstick.
7. Lower the cargo box.

BB87125,0000D97-19-14MAY13

Changing Transaxle Oil

1. Park the machine safely. (See Parking Safely in SAFETY.)

Service Transmission

2. Raise and secure cargo box with latch support.

IMPORTANT: Dirt and debris in oil may cause damage to the transaxle. Clean area around opening before removing dipstick.

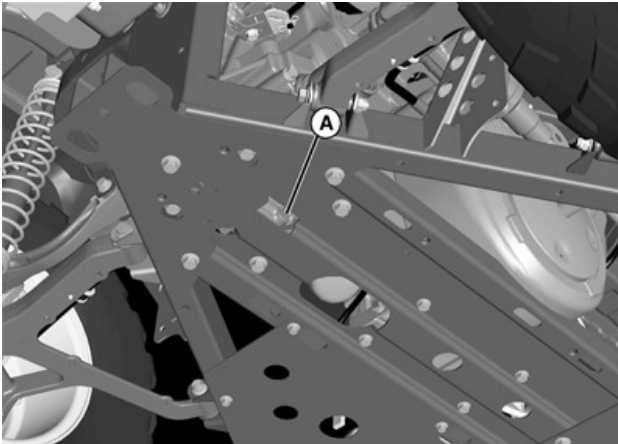

MXAL47357—UN—16APR13

3. Position drain pan under transaxle drain plug (A).
4. Remove plug and drain oil.
5. Check washer on drain plug. Replace if missing or in poor condition.
6. Install and tighten drain plug to specification.

Specification

Transaxle Drain Plug—Torque. 30-35 N·m (22-26 lb-ft)



MXAL47358—UN—16APR13

7. Remove dipstick (B) located on top of transaxle housing. Wipe dipstick clean.
8. Add recommended fluid.
9. Wait for two minutes then check oil level. Add oil if necessary.
10. Install dipstick and tighten.
11. Lower the cargo box.

BB87125.0000D98-19-19APR13

Inspecting Driveline CV Boots

1. Park the machine safely. (See Parking Safely in SAFETY.)

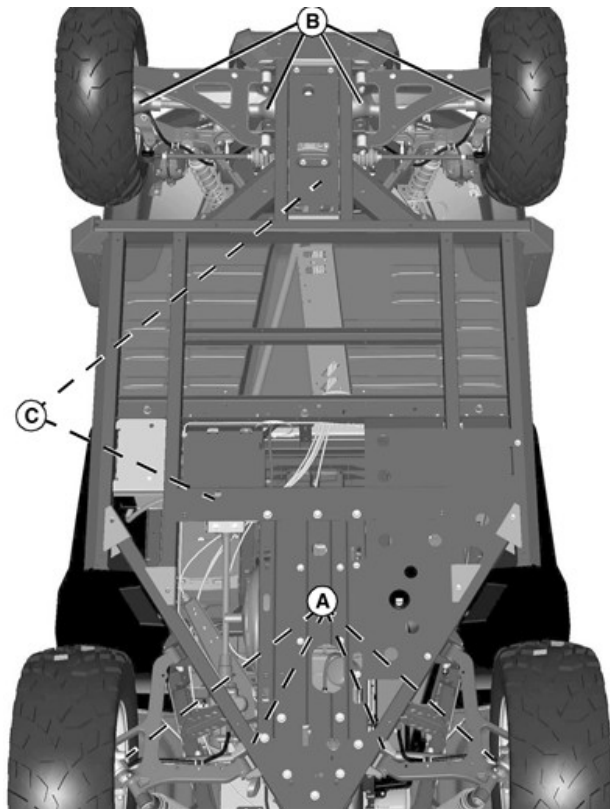

MXAL47359—UN—16APR13

Viewed from under the machine.

2. Inspect four rear CV boots (A) for tears or punctures.
3. Inspect four front CV boots (B) for tears or punctures.
4. Inspect front and rear drive shaft boot (C) for tears or punctures.
5. If replacement of a boot is necessary, see your John Deere dealer.

BB87125.0000D99-19-19APR13

Inspecting Steering Tie Rod Boots

1. Park the machine safely. (See Parking Safely in SAFETY.)

Service Transmission

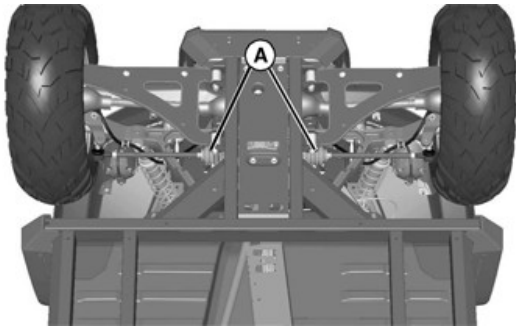

MXAL47360—UN—16APR13

View from under machine.

2. Inspect two front steering tie rod boots (A) for tears or punctures.
3. If replacement of a boot is necessary, see your John Deere dealer.

BB87125,0000D9A-19-19APR13

Servicing Clutches and Drive Belt

⚠ CAUTION: Avoid injury! Rotating parts catch fingers, loose clothing, or long hair. To adjust or service machine, wait for engine and all moving parts to stop before leaving operators station.

1. Park the machine safely. (See Parking Safely in SAFETY.)
2. Remove cargo box. (See Removing and Installing Cargo Box in SERVICE MISCELLANEOUS.)

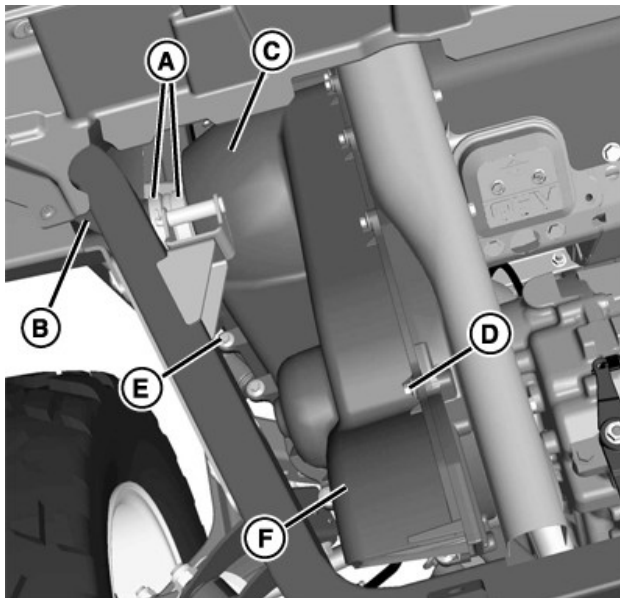

MXT012791—UN—20JAN15

3. Loosen clamps (A) and remove air inlet hose (B) from clutch enclosure (C).

NOTE: Note what hole each bolt came from when removing clutch enclosure cover.

4. Remove seven horizontally installed bolts (D), eight vertically installed bolts (E), and outer clutch enclosure cover (F).

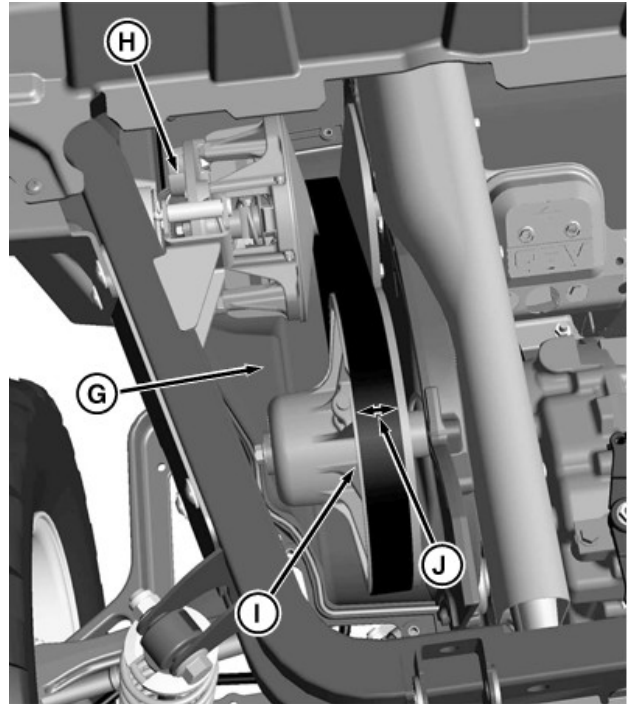

MXT016239—UN—04NOV15

5. Using compressed air, clean inside clutch enclosure cover, clutch enclosure base (G), and drive (H) and driven clutch (I) assemblies.
6. Rotate and inspect drive belt for wear or damage.
7. Measure the top surface of the belt width at (J). Verify that belt width meets minimum width specification.

Specification

Drive Belt Top Surface
Minimum—Width 29 mm (1.1 in)

8. Replace drive belt if necessary. (See Replacing Drive Belt.)
9. Inspect and clean air intake. (See Servicing Air Intake in SERVICE ENGINE.)
10. Install clutch enclosure cover.
11. Install air inlet hose with hose clamps.
12. Install cargo box. (See Removing and Installing Cargo Box in SERVICE MISCELLANEOUS.)

OUMX068,0000EB3-19-04NOV15

Replacing Drive Belt

⚠ CAUTION: Avoid injury! Rotating parts catch fingers, loose clothing, or long hair. To adjust or service machine, wait for engine and all moving parts to stop before leaving operators station.

Service Transmission

1. Park the machine safely. (See Parking Safely in SAFETY.)
2. Remove cargo box. (See Removing and Installing Cargo Box in SERVICE MISCELLANEOUS.)
3. Remove clutch enclosure cover and clean inside. (See Servicing Clutches and Drive Belt.)

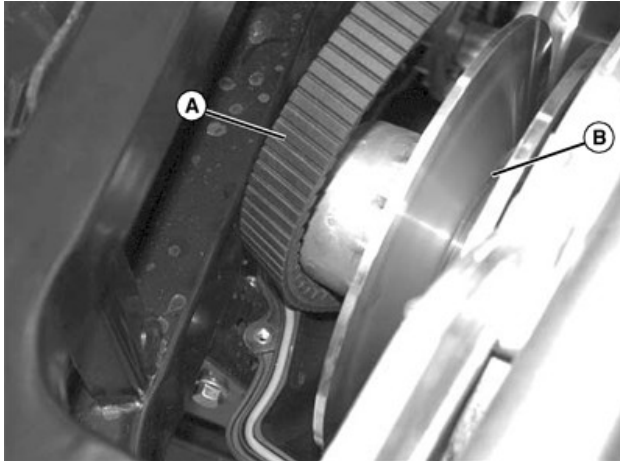

MXAL47364—UN—16APR13

4. Remove drive belt (A) from driven pulley (B).

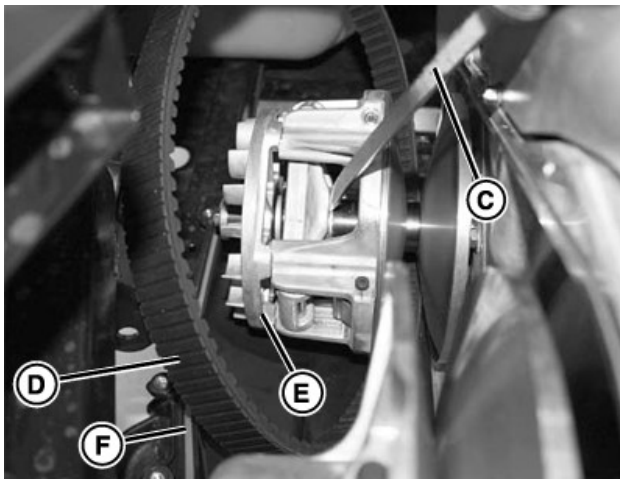

MXT012793—UN—20JAN15

5. Using a screwdriver (C) or pry bar, as shown, pry clutch so that belt (D) clears clutch fan (E) and housing (F).
6. Remove belt.
7. Install new belt.
8. Install clutch enclosure cover.
9. Install air inlet hose with hose clamps.
10. Install cargo box. (See Removing and Installing Cargo Box in SERVICE MISCELLANEOUS.)

OUMX068,0000EB4-19-04NOV15

Checking 4WD and 4WD+Differential Lock Engagement

1. Park the machine safely. (See Parking Safely in SAFETY.)
2. Allow engine to cool.
3. Raise hood.
4. Remove storage tray.
5. Raise and secure cargo box with latch support.

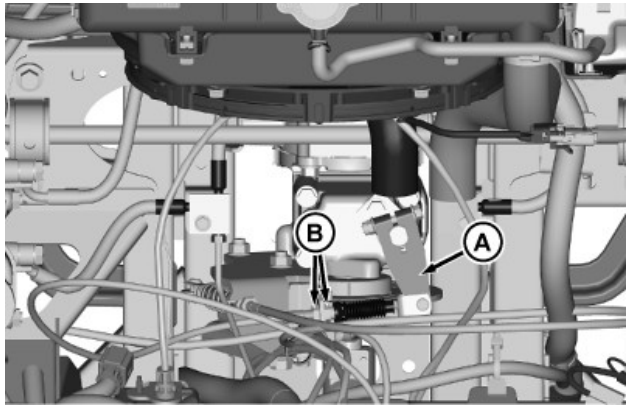

MXT016523—UN—17NOV15

6. Check 4WD engagement:
 - a. With the 2WD/4WD lever in 2WD position, the MFWD shift lever (A) must return to the 'home' position (internal spring), without slack in the cable.
 - b. If adjustment is required, loosen or tighten the adjuster nuts (B) so that there is no slack in the cable, without moving the MFWD lever.

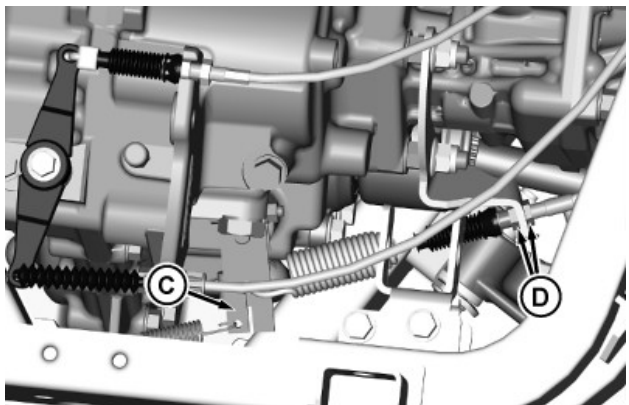

MXT016525—UN—18NOV15

7. Check rear lock engagement:
 - a. With the 2WD/4WD lever in 4WD position, the rear lock lever (C) on the transaxle must return to the 'home' position, without slack in the cable.
 - b. If adjustment is required, loosen or tighten the adjuster nuts (D) so that there is no slack in the cable, without moving the differential lock lever.
8. Lower cargo box.

Service Transmission

9. Install storage tray.
10. Close hood.

OUMX068,0000EF1-19-18NOV15

Service Steering & Brakes

Brake Fluid

John Deere DOT4 heavy duty brake fluid is preferred. Other brands of DOT4 brake fluid may be used.

BB87125,0000D9F-19-19APR13

Checking Brake Fluid Level

IMPORTANT: Avoid damage! Avoid contamination of the brake fluid. Thoroughly clean area around the filler cap before removing. Do not open the brake fluid reservoir cap unless necessary.

Use extreme care when filling the reservoir. Fluid spilled on painted surfaces can cause damage.

Use only brake fluid from a sealed container.

1. Park the machine safely. (See Parking Safely in SAFETY.)
2. Open the hood.

NOTE: Do not overfill reservoir. If you do overfill, leakage occurs.

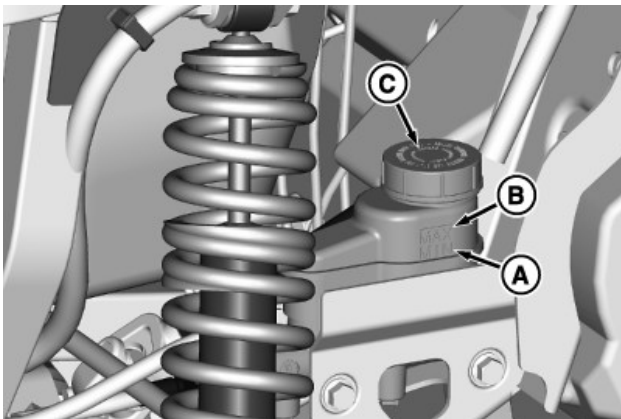

MXT012761—UN—13NOV14

3. Visually check brake fluid reservoir. Brake fluid level must be between “MIN” (A) and “MAX” (B) marks. If fluid is low:

- Carefully clean area around reservoir cap (C).
- Remove reservoir cap and add fluid to the “MAX” mark.

4. Install reservoir cap.
5. Close hood.

OUMX068,0000A8B-19-13NOV14

Checking Brake Pads

1. Park the machine safely. (See Parking Safely in SAFETY.)

CAUTION: Avoid injury! The machine can fall or slip from an unsafe lifting device or supports.

- Use a safe lifting device rated for the load to be lifted.
- Lower machine onto jack stands or other stable supports and block wheels before servicing.

IMPORTANT: Avoid damage! Place jack stands under frame, not under transmission or engine, when raising or supporting machine.

2. Raise machine with a safe lifting device and lower machine onto jack stands or other stable supports. Block wheels remaining on the ground to prevent machine movement.

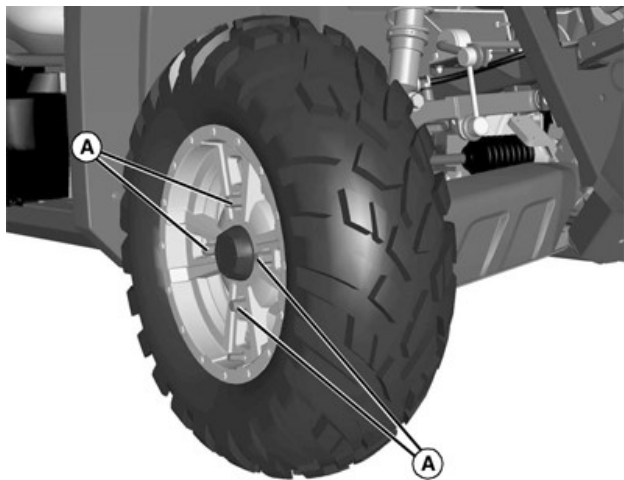

MXAL47375—UN—16APR13

3. Remove four wheel nuts (A).
4. Remove the wheel assembly.

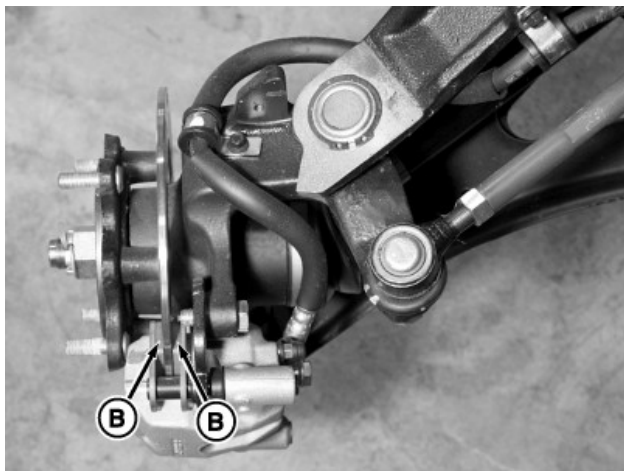

MXT012762—UN—13NOV14

5. Inspect brake pad friction material (B) for wear or damage. Check each pads friction material thickness per specification.

Specification

Brake Pad—Minimum Thickness 1 mm (3/64 in.)

Service Steering & Brakes

If below this specification or brake pad friction material is damaged, see your John Deere dealer for replacement service.

6. Install wheel assembly with valve stem to the outside.
7. Tighten wheel nuts evenly in alternating sequence until snug.
8. Repeat procedure for remaining three wheels.
9. Lower machine completely to the ground.
10. Tighten wheel nuts to specification.

Specification

Standard Wheel Assembly	
(Steel)—Torque	54 N·m (40 lb.-ft.)
Sport Wheel Assembly	
(Alloy)—Torque	142 N·m (105 lb.-ft.)

OUMX068,0000A8C-19-13NOV14

Adjusting Park Brake

For proper adjustment of the park brake system, see your John Deere Dealer.

JG81906,0000742-19-01APR13

Service Electrical

Electrical

WARNING: Battery posts, terminals and related accessories contain lead and lead components, chemicals known to the State of California to cause cancer and reproductive harm. **Wash hands after handling.**

MP47322,00F466E-19-15MAR13

Service the Battery Safely



MXAL41890—UN—18FEB13

CAUTION: Avoid injury! Battery electrolyte contains sulfuric acid. It is poisonous and can cause serious burns:

- Wear eye protection and gloves.
- Keep skin protected.
- If electrolyte is swallowed, get medical attention immediately.
- If electrolyte is splashed into eyes, flush immediately with water for 15-30 minutes and get medical attention.
- If electrolyte is splashed onto skin, flush immediately with water and get medical attention if necessary.

The battery produces a flammable and explosive gas. The battery may explode:

- Do not smoke near battery.
- Wear eye protection and gloves.
- Do not allow direct metal contact across battery posts.
- Remove negative cable first when disconnecting.
- Install negative cable last when connecting.

OOU1023,000009A-19-26MAY15

Checking the Battery (Sealed Batteries)

NOTE: Do not attempt to open, add fluid or service battery. Any attempt to do so will void warranty.

- Keep battery and terminals clean.
- Keep battery bolts tight.
- Keep small vent holes open.

IMPORTANT: This battery comes fully charged. If the machine is not used by the service expiration date indicated on the battery, charge the battery.

- Recharge, if necessary, at 6-10 amperes for 1 hour.

BB87125,0000DA4-19-19APR13

Removing and Installing Battery

Removing

1. Park the machine safely. (See Parking Safely in SAFETY.)
2. Tilt seat forward.

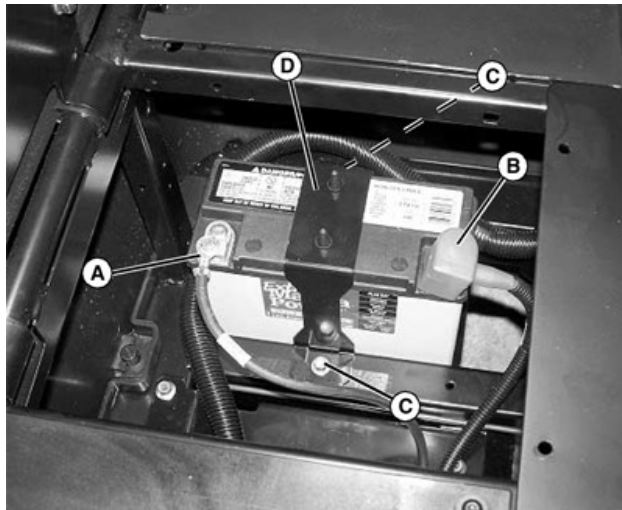

MXAL47378—UN—16APR13

3. Disconnect all black negative cables (A) from battery first.
4. Slide back red protective cover (B) and disconnect all red positive cables.
5. Remove two bolts (C) that secures battery hold-down (D) and remove hold-down from around battery.
6. Lift battery from machine.

Installing

1. Install battery into machine with negative (-) terminal positioned toward front of machine and the battery seated properly in the battery tray.
2. Install battery hold-down firmly against battery and install two bolts to secure.
3. Connect all red positive cables to positive (+) battery terminal first. Tighten the connections.
4. Connect all black negative cables to negative (-) battery terminal. Tighten the connections.

Service Electrical

5. Apply general purpose grease or silicone spray to battery terminals to help prevent corrosion.
6. Slide red protective cover down the battery positive cable and seat it over the positive (+) terminal.
7. Lower seat.

BB87125,0000DA5-19-19APR13

Cleaning Battery and Terminals

1. Park machine safely. (See Parking Safely in the SAFETY section.)
2. Disconnect and remove battery.
3. Wash battery with solution of four tablespoons of baking soda to one gallon of water. Be careful not to get the soda solution into the cells.
4. Rinse the battery with plain water and dry.
5. Clean terminals and battery cable ends with wire brush until bright.
6. Install battery.
7. Attach cables to battery terminals, beginning with the positive cable, using washers and nuts.
8. Apply spray lubricant to terminal to prevent corrosion.

MP47322,00F4671-19-15MAR13

Using Booster Battery

CAUTION: Avoid injury! The battery produces a flammable and explosive gas.

To prevent the battery from exploding:

- Do not smoke or have open flame near battery.
- Wear eye protection and gloves.
- Do not jump-start or charge a frozen battery. Warm battery to specification.

Specification

Battery—Temperature. 16°C (60°F)

- Do not connect the negative (-) booster cable to the negative (-) terminal of the discharged battery. Connect at a good ground location away from the discharged battery.

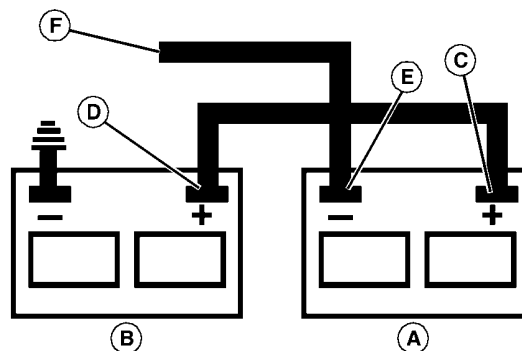

MXAL42872—UN—09APR13

A—Booster Battery
B—Disabled Vehicle Battery
C—Positive (+) Post
D—Positive (+) Post
E—Negative (-) Post
F—Negative (-) Booster Cable End

1. Connect positive (+) booster cable to booster battery (A) positive (+) post (C).
2. Connect the other end of positive (+) booster cable to the disabled vehicle battery (B) positive (+) post (D).
3. Connect negative (-) booster cable to booster battery negative (-) post (E).

IMPORTANT: Avoid damage! Electric charges from the booster battery damages machine components. Do not install negative booster cable to machine frame. Install only to the engine block.

Install negative booster cable away from moving parts in the engine compartment, such as belts and fan blades.

4. Connect the other end (F) of negative (-) booster cable to a metal part of the disabled machine engine block away from battery.
5. Start the engine of the disabled machine and run machine for several minutes.
6. Carefully disconnect the booster cables in the exact reverse order: negative cable first and then the positive cable.

MP47322,00F4672-19-05JUN15

Replacing Headlight Bulb

1. Park the machine safely. (See Parking Safely in SAFETY.)
2. Open the hood.

CAUTION: Halogen light bulb contains gas under pressure. The bulb may shatter if the glass is scratched or dropped. Wear eye protection and handle bulb with care when replacing.

Service Electrical

IMPORTANT: Do not touch glass portion of new bulb with bare skin. Contact with oils or dirt will reduce bulb life. Handle bulb by the base or with a clean cloth or gloves.

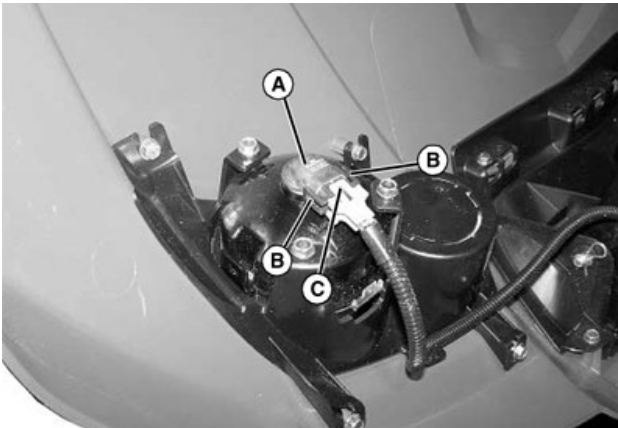

MXAL47380—UN—16APR13

3. Rotate bulb socket (A) 1/8 of a turn counterclockwise and remove socket from housing.
4. Pull outward slightly on tabs (B), and disconnect wire connector (C) from socket. Discard the bulb/socket assembly.
5. Connect wiring connector to new bulb/socket assembly. Install the assembly into housing and rotate 1/8 turn to lock in place.
6. Test head lamp function.

BB87125,0000DA8-19-19APR13

Checking and Replacing Fuses

IMPORTANT: Avoid damage! The electrical system can be damaged if incorrect replacement fuses are used. Replace the bad fuse with a fuse of the same amperage rating.

1. Park the machine safely. (See Parking Safely in SAFETY.)

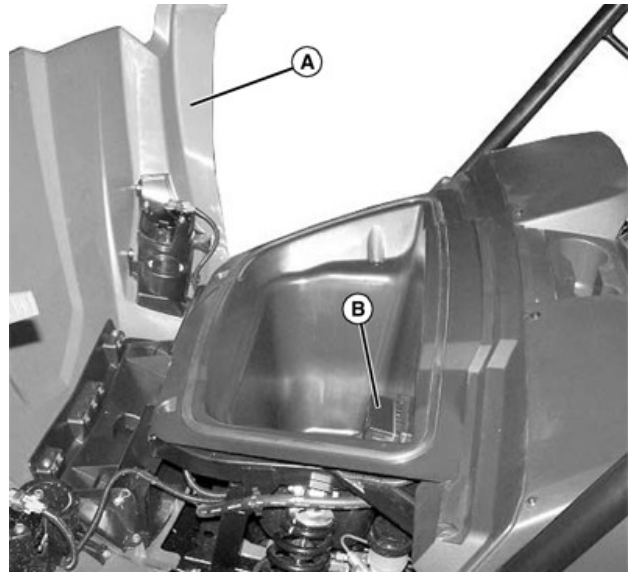

MXAL47381—UN—16APR13

2. Open hood (A) to access the storage tray.
3. Remove fuse box cover (B).

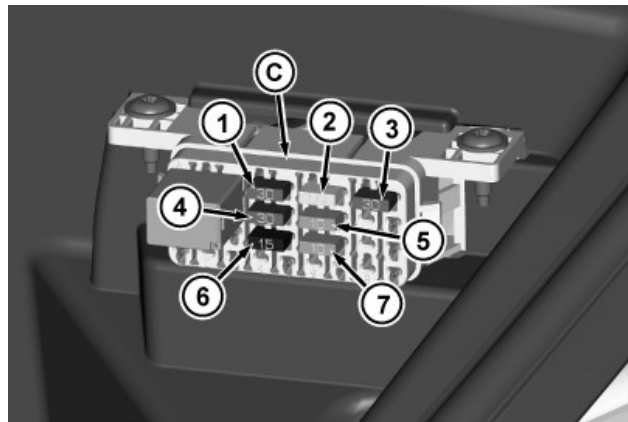

MXT020155—UN—18MAY17

4. Pull fuse from the load center (C) under the storage tray.
5. Fuse identification:

Position	Circuit	Fuse Size
1	Rear Power	30 A
2	Starter	20 A
3	Switch Bank Power	30 A
4	Front Power	30 A
5	Power Port	10 A
6	Key Switch (Keyed Power)	15 A
7	Headlights	10 A

Service Electrical

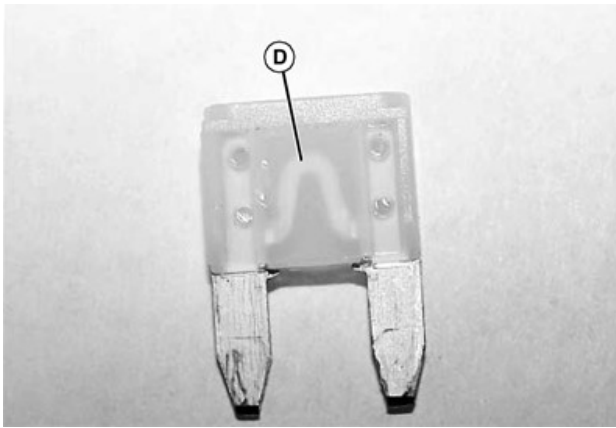

MXAL47383—UN—16APR13

6. Check visually for broken filament at location (D) in fuse.
7. Push new fuse of the correct amperage rating into proper position in the fuse block.
8. Install fuse box cover and close hood.

OUMX068,000129E-19-13JUN17

Replacing Tail Light Bulb

1. Park the machine safely. (See Parking Safely in SAFETY.)

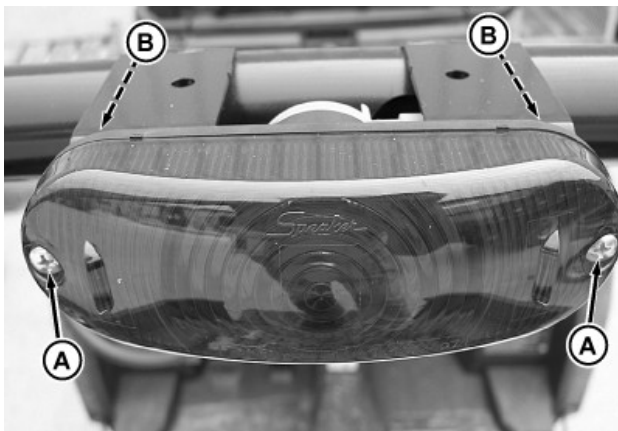

MXT020154—UN—17MAY17

2. Remove screws (A), nuts (B), and tail light lens.

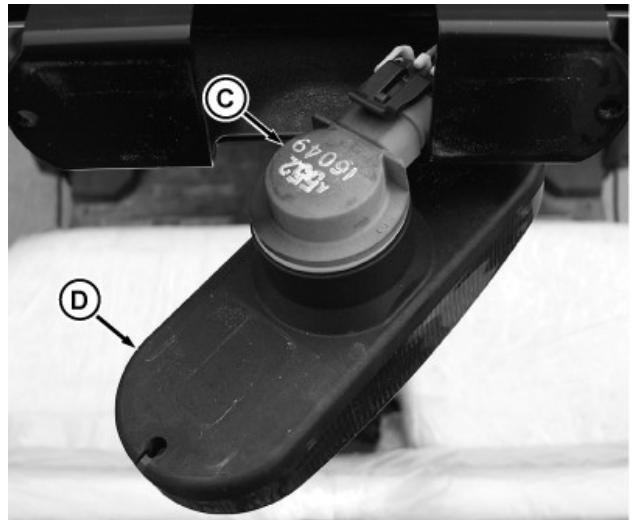

MXT019090—UN—25AUG16

3. Rotate bulb socket (C) 1/8 of a turn counterclockwise and remove socket from the bracket (D).

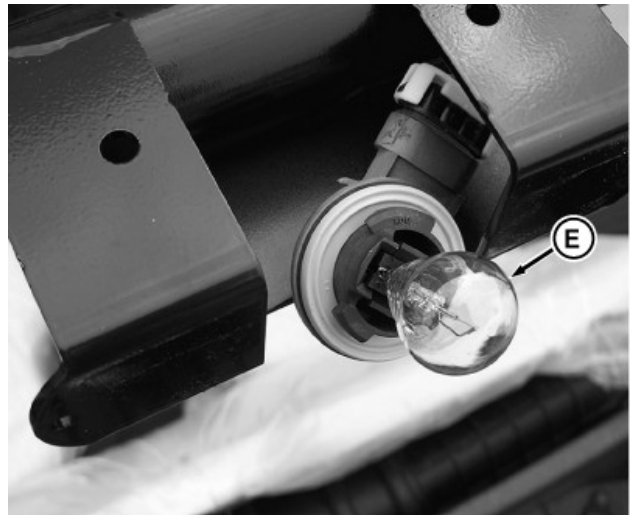

MXT019091—UN—25AUG16

4. Pull bulb (E) outward slightly. Discard the bulb.
5. Install new bulb and test function.
6. Install lens.

JK79365,0000689-19-17MAY17

Service Miscellaneous

Using Proper Fuel and Stabilizer

IMPORTANT: Avoid damage! Using stale, contaminated, or improper fuel can result in engine and fuel system damage. Repairs caused by stale, contaminated, or improper fuel are not covered by warranty.

Use regular grade unleaded fuel with an octane rating of 87 octane or higher. Fuel blends containing up to 10% ethanol or up to 15% MTBE reformulated fuel are acceptable. Do not use fuel or additives containing methanol as engine damage can occur.

Always use fresh, clean fuel that is purchased in a quantity that can be used within approximately 30 days. Fuel stabilizer should always be added to the fuel each time fuel is purchased. Add stabilizer before filling the fuel container to insure proper mixing. Such practice helps prevent engine performance problems and allows fuel storage in the machine all year without draining.

Store fuel in plastic containers to reduce condensation. Make sure that the cap on the fuel container is tight to reduce fuel contamination and evaporation. For best fuel storage life, use a self-sealing gas can.

Fuel is blended to give best seasonal performance. To avoid engine performance problems such as hard starting or vapor lock, use in-season fuel. Use fuel during warm weather that was purchased during that season, and use fuel during cold weather that was purchased during that season.

Fuel can become stale in machines with engines that are used seasonally or infrequently during a season. Stale fuel can produce varnish and plug carburetor or EFI components which can affect engine performance.

Keep fuel storage container tightly covered and in a cool area out of direct sunlight. Fuel can break down and degrade if not sealed properly or exposed to sun and heat.

Condensation may collect in the fuel tank because of a variety of operating or environmental conditions and, over time, may affect your machine's operation. Fill machine fuel tank at the end of the day.

MP47322.00F4674-19-26MAY15

Filling Fuel Tank

CAUTION: Avoid injury! Fuel vapors are explosive and flammable:

- Shut off engine before filling fuel tank.
- Allow engine to cool before refueling.
- Do not smoke while handling fuel.
- Keep fuel away from flames or sparks.
- Fill fuel tank outdoors or in ventilated area.
- Clean up spilled fuel immediately.

- To prevent static electric discharge, use clean approved non-metal container.

IMPORTANT: Avoid damage! Dirt and water in fuel can cause engine damage:

- Clean dirt and debris from the fuel tank opening.
- Use clean, fresh, stabilized fuel.
- To keep condensation out of the fuel tank, fill the fuel tank at the end of each day of operation.
- If using a funnel, make sure it is plastic and has no screen or filter.

To prevent condensation and freezing during cold weather, fill fuel tank at the end of each day of operation.

1. Park the machine safely. (See Parking Safely in SAFETY.)
2. Allow engine to cool.

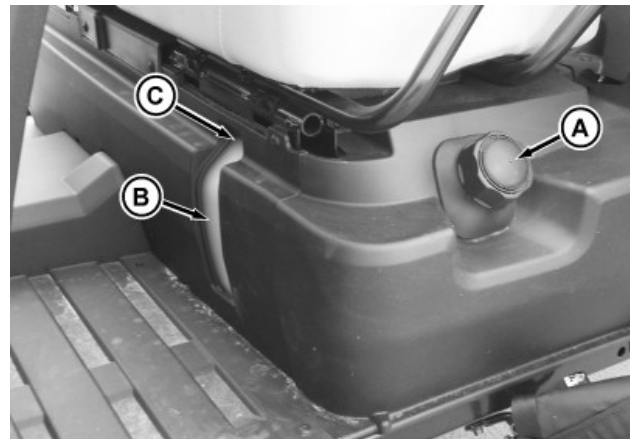

MXT016162—UN—22OCT15

Picture Note: XUV560 S4 model shown.

3. Remove any trash from area around fuel tank cap (A).

IMPORTANT: Avoid damage! No pressure is built up in fuel tank under normal operating conditions. Contact your John Deere dealer if you notice pressure built up when removing fuel tank cap.

4. Remove fuel tank cap slowly to allow any pressure built up in tank to escape.
5. Fill fuel tank (B) to top of tank (C). Do not overfill.
6. Install fuel tank cap.

OUMX068.0000E52-19-01AUG16

Service Miscellaneous

Removing and Installing Wheel Assembly

Removing

1. Park the machine safely. (See Parking Safely in SAFETY.)

⚠ CAUTION: The machine can fall or slip from an unsafe lifting device or supports.

- Use a safe lifting device rated for the load to be lifted.
- Lower machine onto jack stands or other stable supports and block wheels before servicing.

IMPORTANT: Place jack stands under frame, not under transmission or engine, when raising or supporting machine.

2. Raise machine with a safe lifting device and lower machine onto jack stands or other stable supports. Block wheels remaining on the ground to prevent machine movement.



MXAL47385—UN—16APR13

3. Remove four wheel nuts (A).
4. Remove the wheel assembly.

⚠ CAUTION: Explosive separation of tire and rim parts is possible when they are serviced incorrectly:

- Do not attempt to mount a tire without the proper equipment and experience to perform the job.

5. Take wheel assembly to an authorized service dealer for repairs.

Installing

1. Install wheel assembly with valve stem to the outside.
2. Tighten wheel nuts evenly in alternating sequence until snug.

3. Repeat procedure for remaining three wheels.
4. Lower machine completely to the ground.
5. Tighten wheel nuts to specification.

Specification

Standard Wheel Assembly (Steel)—Torque.	54 N·m (40 lb-ft)
Sport Wheel Assembly (Alloy)—Torque.	142 N·m (105 lb-ft)

6. If new nuts or wheels are used, tighten nuts again after 8 hours of machine use.

BB87125,0000DAC-19-14MAY13

Lifting Machine

1. Park the machine safely. (See Parking Safely in the SAFETY section.)

⚠ CAUTION: Avoid injury! The machine can fall or slip from an unsafe lifting device or supports.

- Use a safe lifting device rated for the load to be lifted.
- Lower machine onto jack stands or other stable supports and block wheels before servicing.

NOTE: Remove all attachments before lifting machine.

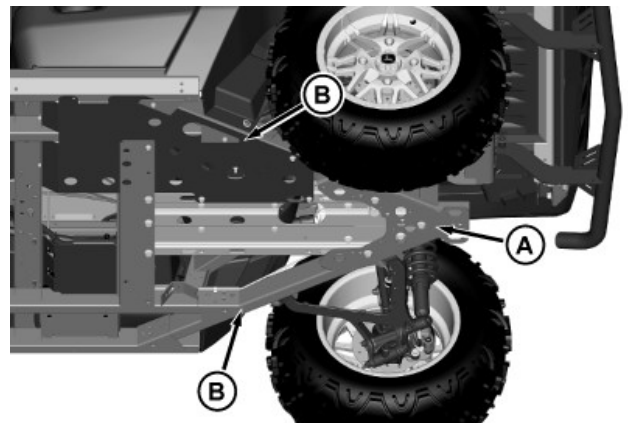

MXT020156—UN—18MAY17

Your machine model may not be shown, but jack locations are as shown.

2. Safely lift rear of the machine at the frame point (A).
3. Place jack stands or other stable supports under frame locations (B).
4. To avoid movement of the machine when only lifting rear of machine, block front wheels remaining on ground.

Service Miscellaneous

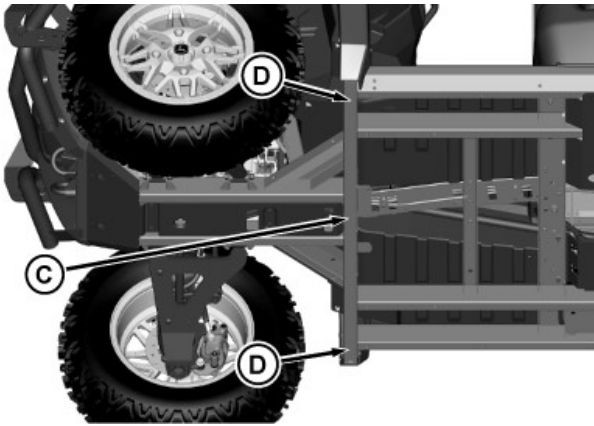

MXTO20157—UN—18MAY17

Your machine model may not be shown, but jack locations are as shown.

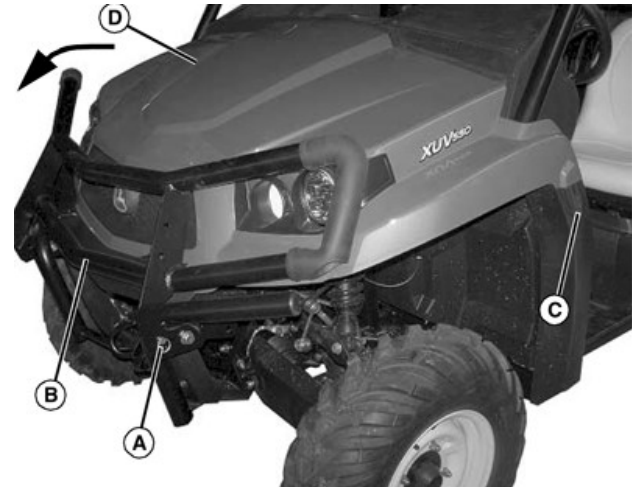

MXAL47388—UN—16APR13

5. Safely lift front of the machine at the frame point (C). Place jack stands or other stable supports under frame locations (D).
6. To avoid movement of the machine when only lifting front of machine, block rear wheels remaining on ground.
7. To lower the machine, lift front and/or rear of machine. Remove jack stands or supports and lower machine.

OUMX068,000129F-19-18MAY17

2. Remove pin (A) on each side of front bumper assembly (B).
3. Rotate top of front bumper forward.
4. Release rubber latch (C) attached to each side of machine.
5. Raise hood (D).
6. Close hood. Secure with two rubber latches. Lower front bumper and secure two pins.

BB87125,0000DAE-19-19APR13

Opening and Closing Hood

CAUTION: Never store flammable, heavy, or loose breakable objects in the storage tray. Always latch hood before operating machine.

IMPORTANT: Do not store items that will not allow the hood to close properly. Properly secure loose or sharp items. These items may damage the storage tray or other items within the tray.

1. Park the machine safely. (See Parking Safely in SAFETY.)

Inspecting Seat Belt

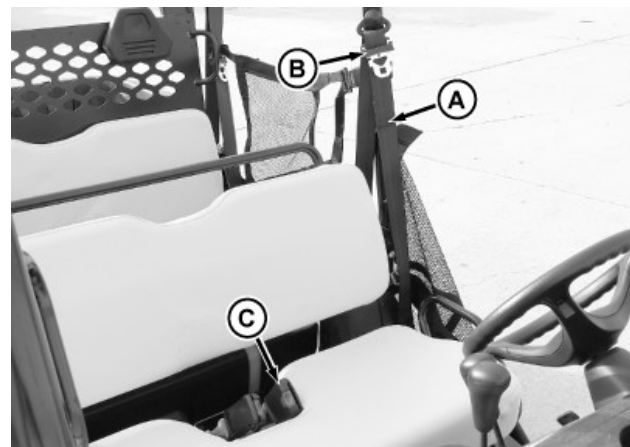

MXTO16163—UN—22OCT15

IMPORTANT: Avoid damage! Do not bleach or dye webbing. Webbing can become severely weakened by this process. Do not use a pressure washer or other automatic washing machine to clean belt or connectors.

- Hand wash webbing (A) with garden hose and mild soap. Rinse thoroughly and air dry.
- Inspect outer seat belt connector (B) and inner connector (C) for damage or wear. If assembly does

Service Miscellaneous

not operate properly or if the webbing is torn or frayed, the seat belt must be replaced.

OUMX068,0000E54-19-22OCT15

Inspecting Nets or Doors

- Keep nets, doors, and supporting components clean.
- If needed hand wash with garden hose and mild soap.
- Latch and unlatch metal tab of net from buckle during washing for better cleaning. Allow to dry before use.
- Extended machine operation under harsh conditions may require more frequent inspection and cleaning.

OUMX068,0000E5-19-04OCT13

Servicing Nets (XUV560 S4)

NOTE: Perform the following procedure for all the nets on your machine.

1. To make sure that the net is taut, follow the Using Nets instructions in OPERATING.



MXT016165—UN—22OCT15

2. To keep nets taut, loosen hardware and adjust clamp (A) as needed. Tighten to 16 N·m (12 lb·ft).

OUMX068,0000E55-19-27OCT15

Cleaning and Repairing Cargo Box

Repairing Accessory Tubes



MXAL47390—UN—16APR13

Use 3M™ Scotchbrite™ pad to polish and smooth nicks, scrapes or scratches in the vinyl surface of the tubes (A).

BB87125,0000DB0-19-19APR13

Removing and Installing Cargo Box

Removing Cargo Box

⚠ CAUTION: Avoid injury! Do not attempt removal of the cargo box without using the latch support.

Empty all material from the cargo box before removing.

1. Empty the cargo box.
2. Park the machine safely. (See Parking Safely in SAFETY.)
3. On machines with a power cargo box lift, disconnect power lift:

Service Miscellaneous

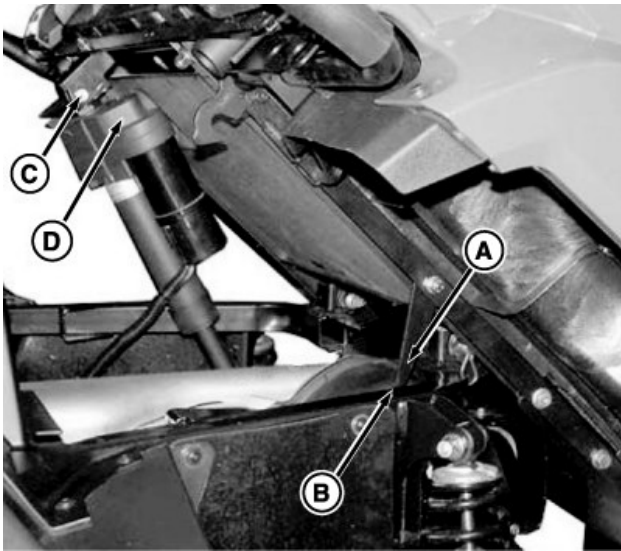

MXT012763—UN—13NOV14

- a. Fully raise cargo box, and lower latch support (A) downward.
- b. Lower cargo box with latch support onto frame (B).
- c. Remove top spring locking pin and cylinder pin (C), and lower top of lift cylinder (D) downward.
- d. Install cylinder pin and spring locking pin back into the lift cylinder for storage.
- e. Raise latch support and fully lower cargo box.

⚠ CAUTION: Avoid injury! Machine component or attachment is heavy. Use a safe lifting device or get an assistant to help lift, install or remove component or attachment.

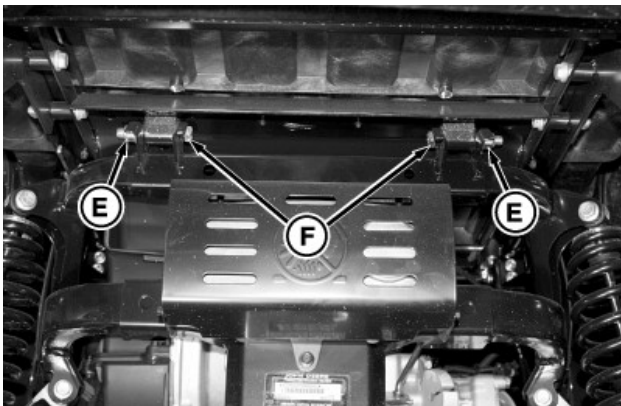

MXT012764—UN—13NOV14

4. Remove nuts (E) and bolts (F). Remove cargo box from machine.
5. Install bolts and nuts back into machine brackets for storage.

Installing Cargo Box

1. Remove bolts and nuts stored in brackets at the rear of the machine.

⚠ CAUTION: Avoid injury! Machine component or attachment is heavy. Use a safe lifting device or get an assistant to help lift, install or remove component or attachment.

2. Carefully position cargo box on top of machine frame with a safe lifting device.

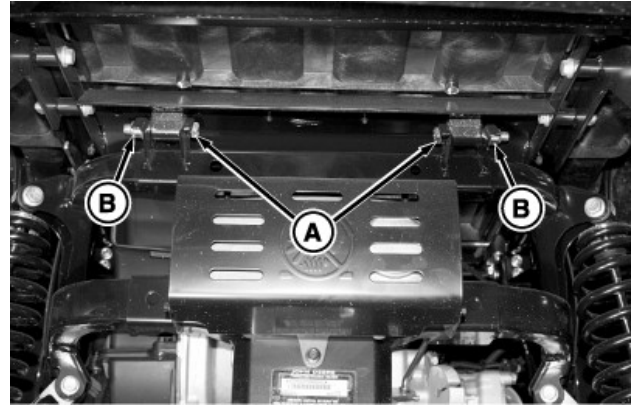

MXT012765—UN—13NOV14

3. Align cargo box tabs and brackets at the rear of the machine, and secure rear of cargo box to the frame with bolts (A) and nuts (B).

⚠ CAUTION: Avoid injury! Make sure cargo box is safely supported in the raised position before connecting the lift cylinder to the bottom of the cargo box.

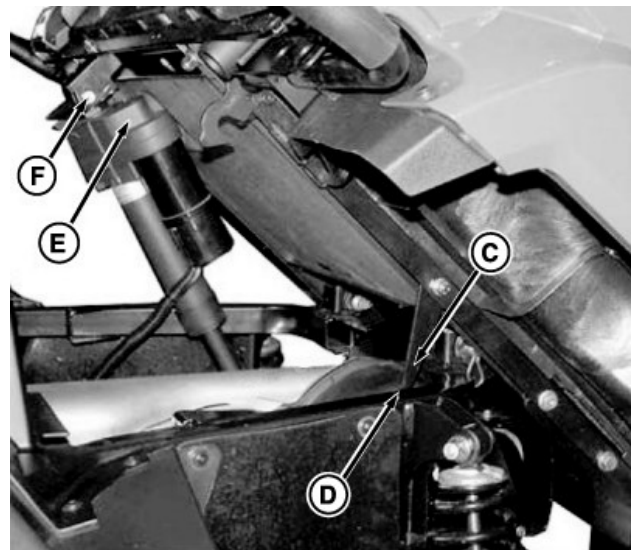

MXT012766—UN—13NOV14

4. On machines with a power cargo box lift, connect power lift:
 - a. Fully raise cargo box and lower latch support (C) downward.
 - b. Lower cargo box with latch support onto frame (D).
 - c. Remove spring locking pin and cylinder pin stored in the lift cylinder.

Service Miscellaneous

- d. Install top of lift cylinder (E) to bracket on cargo box and secure with cylinder pin (F) and spring locking pin.
- e. Raise latch support and fully lower cargo box.

OUMX068,0000A8D-19-13NOV14

Adjusting Cargo Box Latch Brackets

1. Park the machine safely. (See Parking Safely in SAFETY.)
2. Raise and secure cargo box.

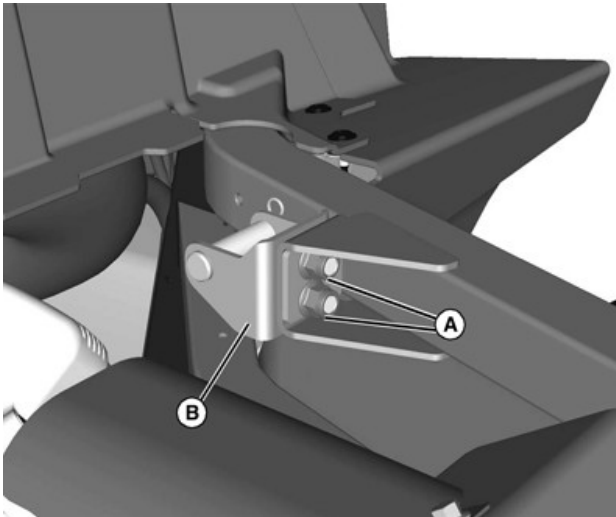

MXAL45787—UN—09APR13

3. Loosen nuts (A) on brackets on both sides of machine.
4. Slide bracket (B) down or up as needed and tighten nuts.
5. Lower cargo box.

RH75544,00001D3-19-08APR13

Checking and Adjusting Toe-In

In order to set front wheel toe-in suspension and steering components must be in good condition. All fasteners must be tightened to specification.

1. Park the machine safely. (See Parking Safely in SAFETY.)
2. Turn steering wheel so that front tires are in straight-ahead position.
3. Check tire pressure. Adjust to specification if needed.

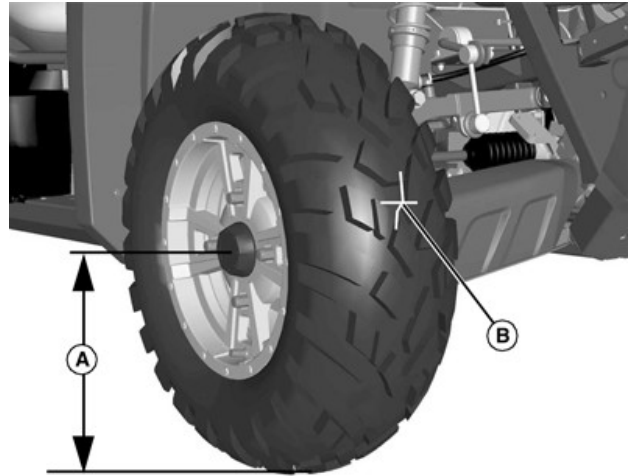

MXAL47395—UN—16APR13

4. Measure front wheel hub center height (A) from surface.
5. Mark tread center line (B) and hub center height at front and back of both front tires.

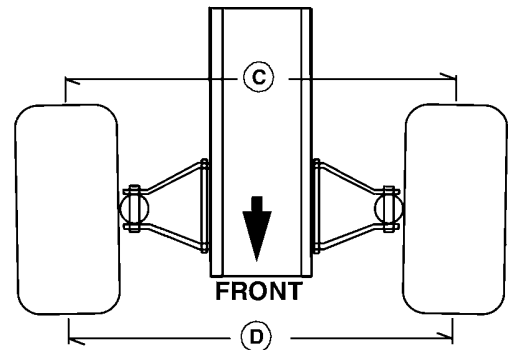

MXAL47396—UN—16APR13

6. Measure distance (C) between tread centerlines at rear of tires at hub height.
7. Measure distance (D) between tread center lines at front of tires at hub height.
8. Subtract front measurement from rear measurement to determine toe-in.
9. Adjust toe-in if not within specification.

Specification

Toe-in—Length. 6 mm (0.24 in.)

NOTE: If the tie rod boot clamp is too tight, the steering rack rubber boot turns with the tie rod. Loosen the boot clamp enough allowing the rubber boot to remain stationary when the tie rod is turned.

Service Miscellaneous

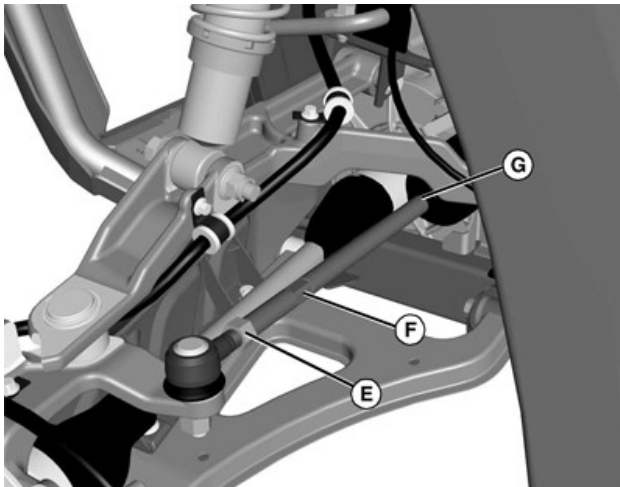

MXAL47397—UN—16APR13

Left side shown.

- Loosen M12 jam nuts (E) on left and right tie rod.
- Rotate tie rod by placing 14 mm wrench on flats (F).
- Loosen boot clamps (G) if necessary to prevent boot rotation with tie rod adjustment.
- Adjust left and right tie rods equally until toe-in is within specification.
- Tighten jam nuts to specification.

Specification

Tie Rod Jam Nuts—Torque. 54N·m (40 lb.-ft.)

- Check that front tires do not contact suspension when turned fully left or right.

OUMX068,0000B8A-19-27MAR15

Adjusting Suspension (Standard Shocks)

Preload Adjustment

When to Adjust:

- Front preload adjustment - increase preload if operating with front attachment or under heavy load condition.
- Rear preload adjustment - increase preload if operating under heavy load condition.

How to Adjust:

- Park the machine safely. (See Parking Safely in SAFETY.)
- Block tire not intended to be lifted off the ground.
- Raise the machine with a safe lifting device and lower machine onto jack stands or other stable support.

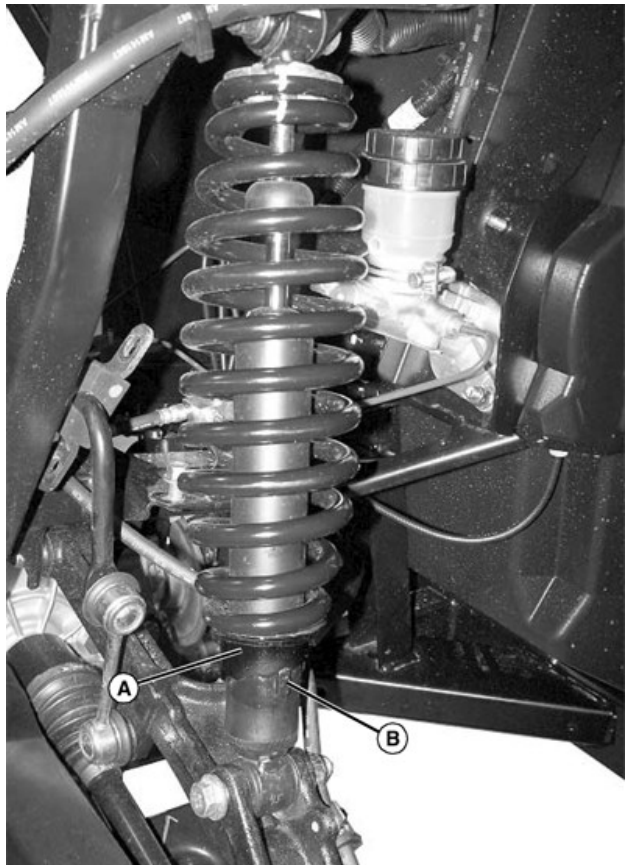

MXAL47398—UN—16APR13

- Using the supplied spanner wrench, securely engage the adjustable preload collar (A) on shock. Rotate preload collar to desired preload condition making sure to engage detent feature (B) between shock and preload collar.

CAUTION: Be sure both front shock preload collars are set to the same position. Be sure both rear shock preload collars are set to the same position.

- Repeat this operation on all shocks as needed.

BB87125,0000DB3-19-19APR13

Cleaning Vehicle Surfaces

Cleaning:

Keeping your vehicle clean will maintain its appearance and can also extend the life of various components. Immediately after your vehicle has been exposed to salt water or operated on muddy trails, rough terrain, or in dusty conditions, wash your vehicle. With some precautions, your vehicle can be cleaned much like a sport utility vehicle.

IMPORTANT: Improper care of machine plastic surfaces can damage that surface:

- Do not wipe plastic surfaces when they are

Service Miscellaneous

dry. Dry wiping will result in minor surface scratches.

- Use a soft, clean cloth (bath towel, diaper, automotive mitt).
- Do not use abrasive materials, such as polishing compounds, on plastic surfaces.

Washing Vehicle:

The recommended and safest way to clean your vehicle is with a garden hose and a pail of mild, soapy water. Use a professional type wash mitt. Clean the upper body first and the lower parts last. Rinse frequently with water and dry with a chamois to prevent water spotting.

1. Rinse hood and entire machine with clean water to remove dirt and dust that may scratch the surface.

IMPORTANT: High pressure may damage vehicle components. It is recommended that your vehicle be washed by hand or with a garden hose using mild soap.

Avoid spraying water with any great force near or into the following places:

- Clutch enclosure air outlet
- Air intake
- Electrical connections (including battery compartment)
- CV boots
- Wheel bearings
- Master cylinder
- Pillow block bearings
- Radiator
- Warning labels
- Decals
- Ignition switch
- Instrument panel (gauges and switches)
- Breather/tube vents

2. Wash surface with clean water and a mild liquid automotive washing soap.
3. Immediately after washing, lubricate all grease fittings with grease.
4. Dry thoroughly to avoid water spots.
5. Wax the surface with a liquid automotive wax. Use products that specifically say “contains no abrasives.”

IMPORTANT: Do not use a power buffer to remove wax.

6. Buff applied wax by hand using a clean, soft cloth.

RH75544,00001D6-19-08APR13

Cleaning and Repairing Metal Surfaces

Cleaning:

Follow automotive practices to care for your vehicle painted metal surfaces. Use a high-quality automotive wax regularly to maintain the factory look of your vehicle's painted surfaces.

Repairing Minor Scratches (surface scratch):

1. Clean area to be repaired thoroughly.

IMPORTANT: Avoid damage! Do not use rubbing compound on painted surfaces.

2. Use automotive polishing compound to remove surface scratches.
3. Apply wax to entire surface.

Repairing Deep Scratches (bare metal or primer showing):

1. Clean area to be repaired with rubbing alcohol or mineral spirits.
2. Use paint stick with factory-matched colors available from your authorized dealer to fill scratches. Follow directions included on paint stick for use and for drying.
3. Smooth out surface using an automotive polishing compound. Do not use power buffer.
4. Apply wax to surface.

MP47322,00F467A-19-26MAY15

Cleaning Plastic Hood and Body Panel Surfaces

IMPORTANT: Avoid damage! Improper care of machine plastic surfaces can damage that surface:

- Do not wipe plastic surfaces when they are dry. Dry wiping will result in minor surface scratches.
- Use a soft, clean cloth (bath towel, diaper, automotive mitt).
- Do not use abrasive materials, such as polishing compounds, on plastic surfaces.

1. Rinse with clean water to remove dirt and dust.
2. Dry thoroughly to avoid water spots.
3. Spray Pledge® onto hood and surfaces and leave on for 30 to 60 seconds.
4. Wipe off with cheesecloth to bring out lustre.

OUMX068,0000BC1-19-06MAY15

Pledge is a trademark of SC Johnson

Service Miscellaneous

Windshield Maintenance

Inspecting Windshield

⚠ CAUTION: Avoid injury! If cracks or surface crazing are observed, or viewing through windshield is impaired, replace windshield.

1. Inspect windshield condition.
2. Fill in existing scratches.
3. Polish or wax windows regularly.

Cleaning Windshield

IMPORTANT: Avoid damage! Some cleaning compounds may attack the polycarbonate material, resulting in cracks that weaken the material.

Never use compounds that contain substances such as ammonia, gasoline, lacquer thinner, and turpentine.

Use of abrasive cleaners on windshield may cause damage.

Never use substances such as acetic acid, acetone, benzene, benzyl alcohol, brake fluid, butyric acid, carbon tetrachloride, ethyl ether, methyl alcohol, phenol, sodium sulfide, sodium hydroxide, sodium nitrate, trichloroethylene, toluene, xylene, or petroleum products.

NOTE: The windshield and windscreen are a polycarbonate material which is softer, but stronger than, glass.

The following cleaning agents are compatible with polycarbonate when used according to the manufacturer's recommendations: Formula 409® (without ammonia), Joy®, Ultra Palmolive® Original, Top Job®, Mr. Clean®, and Fantastik®.

1. Rinse as much loose dirt off as possible with warm water and a soft cloth or sponge before washing.
2. Wash with mild soap or detergent and rinse thoroughly with clean water.
3. Cleaning in direct sunlight causes streaking on surface.
4. Thoroughly dry windshield with a chamois or moist sponge to prevent water spots.

Polishing or Waxing Windshield

Minimize scratches and minor abrasions with a mild automobile polish.

*Formula 409 is a trademark of The Clorox Company
Joy is a trademark of Procter & Gamble
Palmolive is a trademark of The Colgate-Palmolive Company
Top Job is a trademark of KIK Custom Products
Mr. Clean is a trademark of Procter & Gamble
Fantastik is a trademark of SC Johnson*

Test effectiveness of polish or wax in a small corner of windshield before using on entire windshield.

OUMX068.0000BC0-19-05MAY15

Troubleshooting

Using Troubleshooting Chart

If you are experiencing a problem that is not listed in this chart, see your authorized dealer for service.
When you have checked all the possible causes listed and you are still experiencing the problem, see your authorized dealer.

MP47322,00F467B-19-03MAY17

Engine

IF	CHECK
Engine will not start	Battery has low voltage. Loose or corroded battery connections. Blown fuse(s). Spark plug wire(s) is loose or disconnected. Faulty spark plug(s) or coil. No fuel or improper fuel. Plugged fuel filter. Defective starter solenoid. Open-circuit in wiring.
Engine is hard to start	Engine is cold. Plugged fuel filter. Engine oil viscosity too heavy. Spark plug(s) is fouled. Faulty spark plug(s) or wire(s). Loose or corroded electrical connections. Stale or improper fuel. Choke not being used or adjusted incorrectly.
Engine misses under load	Faulty spark plug(s). Stale or dirty fuel. Plugged fuel filter. Faulty coil or wire.
Engine vapor locks	Poor quality fuel or methanol. Very hot weather conditions and very high loading condition. Fuel tank vent plugged. Dirt in fuel filter.
Engine runs unevenly	Loose electrical connections. Choke or throttle cable sticking. Fuel line or fuel filter plugged. Stale or dirty fuel. Improper fuel. Air cleaner element plugged. Spark plug(s) is fouled.
Engine overheats	Air cleaner element missing or plugged. Engine oil low. Engine operated too long at slow engine speed. Carburetor air intake tube plugged. Check thermostat. Check water pump. Check coolant level.
Engine loses power	Engine overheating. Too much oil in engine. Faulty spark plug(s). Fuel supply being restricted. Fuel filter plugged Fuel line pinched or kinked. Improper fuel. Air cleaner element plugged.
Engine knocks	Low engine speed. Stale or low octane fuel. Engine overloaded.

BB87125,0000DB9-19-21MAY13

Troubleshooting

Electrical

IF	CHECK
Starter does not work	Loose or corroded connections. Low battery output. Sulfated or worn out battery. Faulty starter.
Starter cranks slowly	Low battery output. Sulfated or worn out battery. Engine oil too heavy. Loose or corroded connections.
Entire electrical system does not work	Blown fuse. Loose or corroded connections. Sulfated or worn out battery.
Dead battery	Shorted starter solenoid. Key switch not turned to "OFF" position. Component connected to accessory outlet left ON with engine off. Sulfated or worn out battery. Low engine speed or excessive idling. Battery cables and terminals are dirty. Dead cell in the battery. Faulty charging system. Current draw higher than charging system output. (If several attachments are added and used frequently at the same time with the standard charging system. Especially at low engine speeds.)
Correct indicator light(s) do not come on when checking instrument display.	Faulty wiring. Faulty switch or sensor.
Battery will not take a charge	Dead cell in battery. Loose or corroded connections. Sulfated or worn out battery. Electrolyte level low. Low engine speed or excessive idling. Faulty charging system.

BB87125.0000DBA-19-21MAY13

Brakes

IF	CHECK
Brakes not working correctly	Brake fluid level low - check fluid level. Air in brake system, system not bled properly. Replace worn brake pads. (See your John Deere dealer.)

BB87125.0000DBB-19-21MAY13

Cargo Box

IF	CHECK
Tailgate doesn't latch properly	Strikers not connecting - inspect and lubricate strikers.
Power lift doesn't operate	No power - check all power connections. Actuator motor overheated - allow actuator to cool.
Power lift actuator ratchets/clicks/squeals when operating	Too much weight in box - remove weight or move it rearward in box.

BB87125.0000DBC-19-21MAY13

Storage

Storing Safety

CAUTION: Avoid injury! Fuel vapors are explosive and flammable.

Engine exhaust fumes contain carbon monoxide and cause serious illness or death:

- Run the engine only long enough to move the machine to or from storage.
- If a machine is stored before allowing it to cool, machine fires and structure fires can occur. Fires can occur if debris is not removed from around the engine and muffler, or if stored near combustible materials.
- Do not store vehicle with fuel in the tank inside a building where fumes reach an open flame or spark.
- Allow the engine to cool before storing the machine in any enclosure.

MP47322,00F4680-19-06MAY15

Preparing Machine for Storage

1. Repair any worn or damaged parts. Replace parts if necessary. Tighten loose hardware.
2. Repair scratched or chipped metal surfaces to prevent rust.
3. Remove grass and debris from machine.
4. Wash the machine with low pressure water and apply wax to metal and plastic surfaces.
5. Run machine for five minutes to dry belts and pulleys.
6. Apply light coat of engine oil to pivot and wear points to prevent rust.
7. Lubricate grease points.
8. Check tire pressure.

RH75544,00001E0-19-08APR13

Preparing Fuel and Engine for Storage

Fuel:

If you have been using “Stabilized Fuel,” add stabilized fuel to the tank until the tank is full.

NOTE: Filling the fuel tank reduces the amount of air in the fuel tank and helps reduce deterioration of fuel.

If you are not using “Stabilized Fuel:”

1. Park machine safely in a well-ventilated area. (See Parking Safely in the SAFETY section.)

NOTE: Try to anticipate the last time the machine will be used for the season so little fuel is left in the fuel tank.

2. For machines equipped with a key switch, turn key to off position.

IMPORTANT: Avoid damage! Stale fuel can produce varnish and plug carburetor or injector components and affect engine performance.

- Add fuel conditioner or stabilizer to fresh fuel before filling tank.

3. Mix fresh fuel and fuel stabilizer in a separate container. Follow stabilizer instructions for mixing.
4. Fill fuel tank with stabilized fuel.
5. Run engine for a few minutes to allow fuel mixture to circulate through carburetor on gas engine or fuel injectors on diesel engine.

Engine:

Engine storage procedure must be used when vehicle is not to be used for longer than 60 days.

1. Change engine oil and filter while engine is warm.
 2. Service air filter if necessary.
 3. Clean debris from engine air intake screen.
 4. On gas engines:
 - Remove spark plugs. Put 30 mL (1 oz) of clean engine oil in cylinders.
 - Install spark plugs, but do not connect spark plug wires.
 - Crank the engine five or six times to allow oil to be distributed.
 5. Clean the engine and engine compartment.
 6. Remove battery.
 7. Clean the battery and battery posts. Check the electrolyte level, if your battery is not maintenance free.
 8. Close fuel shutoff valve, if your machine is equipped.
 9. Store the battery in a cool, dry place where it will not freeze.
- NOTE: The stored battery should be recharged every 90 days.*
10. Charge the battery.

IMPORTANT: Avoid damage! Prolonged exposure to sunlight could damage the hood surface. Store machine inside or use a cover if stored outside.

Storage

11. Store the vehicle in a dry, protected place. If vehicle is stored outside, put a waterproof cover over it.

OUMX068,00012D2-19-14JUN17

Removing Machine From Storage

1. Check tire pressure.
2. Check engine oil level.
3. Check battery electrolyte level, if your battery is not maintenance free. Charge battery if necessary.
4. Install battery.
5. On gas engines: Check spark plug gap. Install and tighten plugs to specified torque.
6. Lubricate all grease points.
7. Open fuel shut-off valve, if your machine is equipped.
8. Be sure all shields and guards or deflectors are in place.

RH75544,00001E2-19-08APR13

Specifications

Engine

Manufacturer	Briggs & Stratton
Power Rating Information	http://www.briggsandstratton.com
Type	4-cycle Gas, Carbureted
Cylinders	2
Displacement	0.570 L (34.7 in ³)
Bore	72 mm (2.83 in)
Stroke	70 mm (2.76 in)
Lubrication	Pressurized
Oil Filter	Spin On Filter
Cooling System	Air
Air Cleaner	Dry replaceable single element with remote intake
Slow Idle Speed	650—800 rpm
Slow Idle Speed (Governed)	1150 ± 100 rpm
Fast Idle Speed	4100 ± 100 rpm

OUMX068,00008DE-19-26OCT15

Drivetrain and Travel Speeds

Type	Continuously Variable Transmission (CVT) with Clutch Enclosure
Gear Ranges	Forward HI and LO - Neutral - Reverse
Travel Speeds:	
Forward HI	45 km/h (28 mph)
Forward LO	34 km/h (21 mph)
Reverse	26 km/h (16 mph)

BB87125,0000DC1-19-10APR15

Electrical System

Battery Type	12 Volt
Battery Reserve Capacity @ 25A	38 Minutes
Battery Amp Hour Rating @ 27° C (80° F)	30
Cold Cranking Amps @ -18° C (0° F)	340
Charging System: Stator / Flywheel-Type Alternator	
Voltage Rectifier and Regulator Module Output at 1150 RPM (Idle)	7 Amps
Voltage Rectifier and Regulator Module Output at 4100 RPM (Full Throttle)	16 Amps
Spark Plug Gap	0.762 mm (.030 in.)

BB87125,0000DC2-19-19APR13

Fuel System

Fuel Filter	Replaceable Element
Fuel	Gasoline

BB87125,0000DC3-19-19APR13

Specifications

Steering and Brakes

Steering	Rack and Pinion
Brakes	Front/Rear Hydraulic Disc
Brake Pad Minimum Thickness	1 mm (3/64 in.)
Toe-In	6 mm (0.24 in.)

BB87125.0000DC5-19-10APR15

Tires

NOTE: All tire load conditions are not to exceed Gross Vehicle Weight Rating (GVWR). The following tire pressures are for unloaded machines.

Front Tires

Terrahawk AT	25x8-12
Ancla M-T	26x8-12
Maxxis Bighorn 2.0	26x8R14
Inflation Pressure (All Front Tires Unloaded)	97 kPa (0.97 bar) (14 psi)
Inflation Pressure (All Front Tires Loaded @GVWR)	97 kPa (0.97 bar) (14 psi)

Rear Tires

Terrahawk AT	25x10-12
Ancla M-T	36x10-12
Maxxis Bighorn 2.0	26x10R14
Inflation Pressure (All Rear Tires Unloaded)	97 kPa (0.97 bar) (14 psi)
Inflation Pressure Terrahawk and Ancla (Rear Tires Loaded @GVWR) (XUV560)	110 kPa (1.10 bar) (16 psi)
Inflation Pressure Maxxis (Rear Tires Loaded @GVWR) (XUV560)	97 kPa (0.97 bar) (14 psi)
Inflation Pressure Terrahawk and Ancla (Rear Tires Loaded @GVWR) (XUV560 S4)	166 kPa (166 bar) (24 psi)
Inflation Pressure Maxxis (Rear Tires Loaded @GVWR) (XUV560 S4)	152 kPa (152 bar) (22 psi)

OUMX068.00012CE-19-13JUN17

Capacities

Fuel Tank	18.5 L (4.9 gal)
Engine Oil Capacity (with filter change)	48 oz
4WD Front Differential	0.4 L (13.5 oz)
Transaxle	2.6 L (2.75 qt)
Payload Capacity (XUV560)	363 kg (800 lb)
Payload Capacity (XUV560 S4)	544 kg (1200 lb)
Cargo Box Capacity (Not to exceed GVW)	182 kg (400 lb)
Towing Capacity (Not to exceed GVW)	499 kg (1100 lb)

OUMX068.0000E6E-19-27OCT15

Dimensions (XUV560)

Width (overall)	1.45 m (57 in)
Length (with bumper)	2.92 m (115 in)
Height (with Protective Structure)	1.88 m (74 in)
Ground Clearance	26.7 cm (10.5 in)

Specifications

OUMX068,00012CF-19-13JUN17

Dimensions (XUV560 S4)

Width (overall)	1.45 m (57 in)
Length (with bumper)	3.71 m (146 in)
Height (with Protective Structure)	1.88 m (74 in)
Ground Clearance	23.6 cm (9.3 in)

OUMX068,0000E5F-19-27OCT15

Weights (XUV560)

Weight (Empty vehicle with full fluids)	576 kg (1270 lb)
Gross Vehicle Weight Rating (GVWR)	955 kg (2105 lb)
Maximum Trailer Tongue Weight	50 kg (110 lb)
Maximum Front Axle Load	545 kg (1202 lb)
Maximum Rear Axle Load	750 kg (1653 lb)

OUMX068,00012D0-19-27JUN17

Weights (XUV560 S4)

Weight (Empty vehicle with full fluids)	679 kg (1497 lb)
Gross Vehicle Weight Rating (GVWR)	1238 kg (2730 lb)
Maximum Trailer Tongue Weight	50 kg (110 lb)
Maximum Front Axle Load	545 kg (1202 lb)
Maximum Rear Axle Load	750 kg (1653 lb)

OUMX068,00012D1-19-27JUN17

Recommended Lubricants

Engine Oil	John Deere PLUS-4™
.	John Deere TURF-GARD™
Grease	John Deere Multi-Purpose HD Lithium Complex Grease
.	Grease-Gard™ Premium Plus
Transmission Oil (Transaxle)	John Deere HY-GARD™ (JDM J20C)
Transmission Oil (4WD Front Differential)	John Deere Low Viscosity HY-GARD™ (JDM J20D)

(Specifications and design subject to change without notice.)

OUMX068,0000AA4-19-20NOV14

Warranty

Product Warranty

John Deere offers a standard warranty on new John Deere products. For a copy of the product warranty statement or for details on the warranty terms and conditions for products purchased in the United States and Canada, please contact your local John Deere Dealer or utilize the following resources:

United States

Website:

http://www.deere.com/en_US/services_and_support/warranty/warranty.page

Toll Free: 1-800-537-8233

Dealer Locator:

<http://dealerlocator.deere.com/servlet/country=US>

Canada

Website (English):

http://www.deere.ca/en_CA/services_and_support/service_plans_warranties/service_plans_warranties.page

Website (French):

http://fr.deere.ca/en_CA/services_and_support/service_plans_warranties/service_plans_warranties.page

Toll Free: 1-800-537-8233

Dealer Locator:

<http://dealerlocator.deere.com/servlet/country=CA>

Emission-related warranties are included in this Operator's Manual, and applicable if required by law or regulation.

For products purchased in a country other than the United States or Canada, please contact your local John Deere dealer for assistance.

MP47322,00F4690-19-09JUL15

EMISSION-RELATED WARRANTY STATEMENT OFF-ROAD UTILITY VEHICLE OVER 25 MPH

YOUR WARRANTY RIGHTS AND OBLIGATIONS

To determine if the John Deere off-road utility vehicle qualifies for the additional warranties set forth below, look for the "Vehicle Emission Control Information" label located on the vehicle. If the vehicle is operated in the United States or Canada and the "Vehicle Emissions Control Information" label states: "This vehicle meets U. S. EPA exhaust and evap regulations" refer to the "United States and Canada Emission-Related Warranty Statement." If the vehicle is operated in California, and the label states: "This vehicle meets California

regulations" also refer to the "California Evaporative Emissions Control System Warranty Statement."

UNITED STATES AND CANADA EMISSIONS-RELATED WARRANTY STATEMENT

Warranties stated on this certificate refer only to emissions-related parts and components of your engine. The complete engine warranty, less emissions-related parts and components, is provided separately. If you have a question about your emissions warranty coverage, how to make an emissions warranty claim or how to make arrangements for emissions-related authorized repairs, you should contact your John Deere Turf and Utility retailer, or the John Deere Customer Contact Center at 1-800-537-8233, or email John Deere from https://www.deere.com/en_US/services_and_support/technology-solutions/stellarsupport/answer-center/turf-answer-center.page

JOHN DEERE'S WARRANTY RESPONSIBILITY:

John Deere warrants to the ultimate purchaser and each subsequent purchaser that this off-road utility vehicle engine and equipment, including all parts of its emission-control system was designed, built and equipped so as to conform at the time of sale with 40 CFR Part 1051 and Section 213 of the Clean Air Act and is free from defects in materials and workmanship that would cause the engine to fail to conform with applicable US EPA regulations. The emission-related warranty period for vehicles without an odometer is 30 months from when the engine is placed into service. The emission-related warranty period for vehicles with an odometer is 30 months from when the engine is placed into service, 500 hours or 5000 kilometers, whichever comes first, after the engine and equipment is delivered to the ultimate purchaser.

Where a warrantable condition exists, John Deere will repair or replace, as it elects, any part or component with a defect in materials or workmanship that would increase the engine's emissions of any regulated pollutant within the stated warranty period at no cost to you, including expenses related to diagnosing and repairing or replacing emission-related parts. Coverage under this warranty includes, but is not limited to, the parts listed below (the emissions control system parts) to the extent these parts were present on the engine and equipment purchased. Warranty coverage is subject to the limitations and exclusions set forth herein. Emission-related components include engine parts developed to control emissions related to the following:

I. For exhaust emissions, emission-related components include any engine parts related to the following systems:

1. Air-induction system.
2. Fuel system.
3. Ignition system.
4. Exhaust gas recirculation systems.

Warranty

II. The following parts are also considered emission-related components for exhaust emissions:

1. Aftertreatment devices.
2. Crankcase ventilation valves.
3. Sensors.
4. Electronic control units.

III. The following parts are considered emission-related components for evaporative emissions:

1. Fuel Tank.
2. Fuel Cap.
3. Fuel Line.
4. Fuel Line Fittings.
5. Clamps*.
6. Pressure Relief Valves*.
7. Control Valves*.
8. Control Solenoids*.
9. Electronic Controls*.
10. Vacuum Control Diaphragms*.
11. Control Cables*.
12. Control Linkages*.
13. Purge Valves.
14. Vapor Hoses.
15. Liquid/Vapor Separator.
16. Carbon Canister.
17. Canister Mounting Brackets.
18. Carburetor Purge Port Connector..
19. Carburetor bowl gaskets

***As related to the evaporative emission control system.**

EMISSION-RELATED WARRANTY EXCLUSIONS:

John Deere may deny emission-related warranty claims for malfunctions or failures caused by:

- Non-performance of maintenance requirements listed in the Operator's Manual.
- The use of the engine / equipment in a manner for which it was not designed.
- Abuse, neglect, improper maintenance or unapproved modifications or alterations.
- Accidents for which John Deere does not have responsibility or by acts of God.

The off-road utility vehicle engine is designed to operate on those fuels specified in the Fuels, Lubricants and Coolants section in the Operators Manual. Use of any other fuel can harm the emissions control system of the engine / equipment and is not approved for use.

To the extent permitted by law John Deere is not liable for damage to other engine components caused by a

failure of an emission-related part, unless otherwise covered by standard warranty, nor shall it be liable for travel or mileage expenses on emissions warranty service calls.

Limited Liability

a. The liability of John Deere under this Emission-Related Warranty is limited solely to the remedying of defects in materials or workmanship. This warranty does not cover inconvenience or loss of use of the off-road utility vehicle engine and equipment or transportation of the equipment to or from the John Deere Turf and Utility retailer. John Deere shall not be liable for any other expense, loss, or damage, whether direct, incidental, consequential or exemplary arising in connection with the sale or use of or inability to use the off-road utility vehicle engine and equipment for any other purpose.

b. THIS WARRANTY AND ANY OTHER APPLICABLE JOHN DEERE WARRANTIES ARE EXPRESSLY IN LIEU OF ANY OTHER WARRANTIES, EXPRESS OR IMPLIED, INCLUDING ANY WARRANTY OF MERCHANTABILITY OR FITNESS FOR A PARTICULAR PURPOSE. REMEDIES UNDER THIS WARRANTY ARE LIMITED TO THE PROVISIONS OF MATERIAL AND SERVICES AS SPECIFIED HEREIN. WHERE PERMITTED BY LAW, NEITHER JOHN DEERE NOR ANY AUTHORIZED JOHN DEERE ENGINE DISTRIBUTOR, DEALER, OR REPAIR FACILITY OR ANY COMPANY AFFILIATED WITH JOHN DEERE WILL BE LIABLE FOR INCIDENTAL OR CONSEQUENTIAL DAMAGES.

c. No dealer is authorized to modify this John Deere and Federal Emission-Related Warranty.

CALIFORNIA EVAPORATIVE EMISSIONS CONTROL WARRANTY STATEMENT

To determine if the John Deere off-highway recreational vehicle qualifies for the additional warranties set forth below, look for the "Vehicle Emission Control Information" label located on the vehicle. If the vehicle is operated in the United States or Canada and the "Vehicle Emissions Control Information" label states: "This vehicle meets U.S. EPA exhaust and evap regulations" refer to the "United States and Canada Emission-Related Warranty Statement." If the vehicle is operated in California, and the label states: "This vehicle meets California regulations" also refer to the "California Evaporative Emissions Control System Warranty Statement."

YOUR WARRANTY RIGHTS AND OBLIGATIONS

The California Air Resources Board and John Deere are pleased to explain the evaporative emissions control system warranty on your 2018 or 2019 off-highway recreational vehicle. In California, new off-highway recreational vehicles must be designed, built, and equipped to meet the State's stringent anti-smog standards. John Deere must warrant the evaporative emissions control system on your off-highway recreational vehicle for the periods of time listed below

Warranty

provided there has been no abuse, neglect, improper maintenance, or unapproved modification of your off-highway recreational vehicle.

Your evaporative emissions control system may include parts such as the carburetor or fuel-injection system, fuel tank, fuel hoses, carbon canister, and engine computer. Also included may be hoses, belts, connectors and other evaporative emissions-related assemblies. Where a warrantable condition exists, John Deere will repair your off-highway recreational vehicle at no cost to you including diagnosis, parts and labor.

JOHN DEERE'S WARRANTY COVERAGE:

For 2018 and later model year off-highway recreational vehicles, the warranty period for this off-highway recreational vehicle is 30 months, or 2500 miles, or 250 hours, whichever comes first, except for "high-priced" warranty parts [for example: fuel tanks, fuel injectors (if installed), and carburetors (if installed)], which are covered for 60 months, or 5000 miles, or 500 hours, whichever comes first, after the engine and equipment is delivered to the ultimate purchaser.

The following parts are considered emission-related components for evaporative emissions:

1. Fuel Tank**
2. Fuel Cap
3. Fuel Line
4. Fuel Line Fittings
5. Clamps*
6. Pressure Relief Valves*
7. Control Valves*
8. Control Solenoids*
9. Electronic Controls*
10. Vacuum Control Diaphragms*
11. Control Cables*
12. Control Linkages*
13. Purge Valves
14. Vapor Hoses
15. Liquid/Vapor Separator
16. Carbon Canister
17. Canister Mounting Brackets
18. Carburetor Purge Port Connector
19. Carburetor bowl gaskets
20. Carburetor**
21. Fuel Injector**

***As related to the evaporative emission control system.**

****Denotes "high-priced warranty parts."**

If any evaporative emissions-related part on your off-highway recreational vehicle is defective the part will be repaired or replaced by John Deere.

OWNER'S WARRANTY RESPONSIBILITIES:

As the off-highway recreational vehicle owner you are responsible for the performance of the required maintenance listed in your owner's manual. John Deere recommends that you retain all receipts covering maintenance on your off-highway recreational vehicle, but John Deere cannot deny warranty solely for the lack of receipts or for your failure to ensure the performance of a scheduled maintenance.

As an owner you are responsible for presenting your off-highway recreational vehicle to a John Deere dealer as soon as a problem exists. The warranty repairs should be completed in a reasonable amount of time, not to exceed 30 days.

As an off-highway recreational vehicle owner, you should also be aware that John Deere may deny you warranty coverage if your off-highway recreational vehicle or a part has failed due to abuse, neglect, improper maintenance or unapproved modifications.

If you have any questions regarding your warranty rights and responsibilities, you should contact a John Deere Turf and Utility retailer, or the John Deere Customer Contact Center at 1-800-537-8233, or email John Deere from https://www.deere.com/en_US/services_and_support/technology-solutions/stellarsupport/answer-center/turf-answer-center.page or the California Air Resources Board at 9528 Telstar Avenue, El Monte, CA 91731.

ADDITIONAL EVAPORATIVE EMISSIONS CONTROL SYSTEM WARRANTY INFORMATION:

Subject to the conditions and exclusions of the Limited Liability Section below, the warranty on emissions-related parts must function as follows:

(1) Any warranted part which is not scheduled for replacement as part of maintenance in the written instructions (see the "Service Intervals" section of the Operator's manual) must be warranted for the warranty period defined in the Warranty Coverage section above. If any such part fails during the warranty period, it must be repaired or replaced by John Deere according to part 4 of this section. Any such part repaired or replaced under warranty must be fully warranted.

(2) Any warranted part which is scheduled only for regular inspection in the written instructions (see the "Service Intervals" section of the Operator's manual) must be warranted for the Warranty Coverage section above. A statement in such written instructions to the effect of "repair or replace as necessary" must not reduce the period of warranty coverage. Any such part repaired or replaced under warranty must be warranted for the remaining warranty period.

(3) Any warranted part which is scheduled for replacement as part of maintenance in the written instructions (see the "Service Intervals" section of the Operator's manual) must be warranted for the period of time prior to the first scheduled replacement point for

Warranty

that part. If the part fails before the first scheduled replacement point, the part must be repaired or replaced by John Deere according to part 4 of this section. Any such part repaired or replaced under warranty must be warranted for the remainder of the period prior to the first scheduled replacement point for the part.

(4) Repair or replacement of any warranted part under this warranty must be performed at no charge to the off-highway recreational vehicle owner, at a warranty station, except in the case of a temporary repair when a warranted part or a warranty station is not reasonably available to the off-highway recreational vehicle owner. In the event a temporary repair is permitted under this warranty, repairs may be performed at any available service establishment, or by the owner, using any replacement part. John Deere must reimburse the owner for his or her expenses including diagnostic charges for such temporary repair or replacement, not to exceed John Deere's suggested retail price for all warranted parts replaced and labor charges based on John Deere's recommended time allowance for the warranty repair and the geographically appropriate hourly labor rate.

(5) Warranty services or repairs must be provided at all John Deere dealerships.

(6) The off-highway recreational vehicle owner must not be charged for diagnostic labor which leads to the determination that a warranted part is, in fact, defective, provided that such diagnostic work is performed at a warranty station.

(7) John Deere is liable for damages to other vehicle components proximately caused by a failure, under warranty, of any warranted part.

(8) Throughout the off-highway recreational vehicle's warranty period defined in the Warranty Coverage section above, John Deere must maintain a supply of warranted parts sufficient to meet the expected demand for such parts. The lack of availability of such parts or the incompleteness of repairs within a reasonable time period, not to exceed 30 days from the time the off-highway recreational vehicle is initially presented to the warranty station for repair, will qualify the need for a temporary repair for purposes of part 4 of this section.

(9) Any replacement part designated by John Deere may be used in warranty repairs provided without charge to the off-highway recreational vehicle owner. Such use will not reduce the warranty obligations of John Deere, except that John Deere will not be liable under this Warranty for repair or replacement of any replacement part which is not a warranted part (except as provided under part 7 of this section).

(10) Any add-on or modified part exempted by the Air Resources Board from the prohibitions of section 27156 of the California Vehicle Code may be used on an off-highway recreational vehicle. Such use, in and of itself, will not be grounds for disallowing a warranty claim made under this Warranty. John Deere is not liable

under this Warranty to warrant failures of warranted parts caused by the use of an add-on or modified part(s) unless such part(s) are also warranted.

Limited Liability

a. The liability of John Deere under this Evaporative Emissions Control Warranty is limited solely to the remedying of defects in materials or workmanship. This warranty does not cover inconvenience or loss of use of the off-highway recreational vehicle engine and equipment or transportation of the equipment to or from the John Deere Turf and Utility retailer. John Deere shall not be liable for any other expense, loss, or damage, whether direct, incidental, consequential or exemplary arising in connection with the sale or use of or inability to use the off-road utility vehicle engine and equipment for any other purpose.

b. THIS WARRANTY AND ANY OTHER APPLICABLE JOHN DEERE WARRANTIES ARE EXPRESSLY IN LIEU OF ANY OTHER WARRANTIES, EXPRESS OR IMPLIED, INCLUDING ANY WARRANTY OF MERCHANTABILITY OR FITNESS FOR A PARTICULAR PURPOSE. REMEDIES UNDER THIS WARRANTY ARE LIMITED TO THE PROVISIONS OF MATERIAL AND SERVICES AS SPECIFIED HEREIN. WHERE PERMITTED BY LAW, NEITHER JOHN DEERE NOR ANY AUTHORIZED JOHN DEERE ENGINE DISTRIBUTOR, DEALER, OR REPAIR FACILITY OR ANY COMPANY AFFILIATED WITH JOHN DEERE WILL BE LIABLE FOR INCIDENTAL OR CONSEQUENTIAL DAMAGES.

c. No dealer is authorized to modify this John Deere and California Evaporative Emissions Control Warranty.

TC00531,00000EE-19-11MAY17

Tire Warranty

John Deere warranty applies for tires available through the John Deere parts system. For tires not available through the John Deere parts system, the tire manufacturer's warranty applicable to your machine may not apply outside the U.S. (See your John Deere dealer for specific information.)

MX00654,0000314-19-21AUG14

Limited Battery Warranty For Factory Installed Batteries

NOTE: Applicable in North America only. For complete machine warranty, reference a copy of the John Deere warranty statement. Contact your John Deere dealer to obtain a copy.

TO SECURE WARRANTY SERVICE

The purchaser must request warranty service from a John Deere dealer authorized to sell John Deere

Warranty

batteries, and present the battery to the dealer with the top cover plate codes intact.

FREE REPLACEMENT PERIOD

Any new battery which becomes unserviceable (not merely discharged) due to defects in material or workmanship within the FREE REPLACEMENT PERIOD will be replaced free of charge. Installation costs will be covered by warranty if the unserviceable battery was installed by a John Deere factory or dealer and the replacement battery is installed by a John Deere dealer.

PRO RATA ADJUSTMENT (batteries with letter code identification only)

Any new battery which becomes unserviceable (not merely discharged) due to defects in material or workmanship within the Pro Rata Warranty Period will be replaced upon payment of the battery's current list price less a pro rata credit for unused months of service. The applicable adjustment period is determined from the Warranty Code printed at the top of the battery and table below. Installation costs are not covered after the battery warranty period has ended.

THIS WARRANTY DOES NOT COVER

- A. Breakage of the container, cover, or terminals.
- B. Depreciation or damage caused by lack of reasonable and necessary maintenance or by improper maintenance.
- C. Transportation, mailing, or service call charges for warranty service.
- D. Batteries that are merely discharged.

LIMITATION OF IMPLIED WARRANTIES AND PURCHASER'S REMEDIES

To the extent permitted by law, neither John Deere nor any company affiliated with it makes any warranties, representations, or promises as to the quality, performance or freedom from defect of the products covered by this warranty. IMPLIED WARRANTIES OF MERCHANTABILITY AND FITNESS FOR A PARTICULAR PURPOSE, TO THE EXTENT APPLICABLE, SHALL BE LIMITED IN DURATION TO THE APPLICABLE ADJUSTMENT PERIOD SET FORTH HERE. THE PURCHASER'S ONLY REMEDIES IN CONNECTION WITH THE BREACH OR PERFORMANCE OF ANY WARRANTY ON JOHN DEERE BATTERIES ARE THOSE SET FORTH HERE. IN NO EVENT WILL THE DEALER, JOHN DEERE OR ANY COMPANY AFFILIATED WITH JOHN DEERE BE LIABLE FOR INCIDENTAL OR CONSEQUENTIAL DAMAGES. (Note: Some states do not allow limitations on how long an implied warranty lasts or the exclusion or limitation of incidental or consequential damages. So these limitations and exclusions may not apply to you.) This warranty gives you specific legal rights, and you may also have some rights which vary from state to state.

NO DEALER WARRANTY

The selling dealer makes no warranty of its own and the dealer has no authority to make any representation or promise on behalf of John Deere, or to modify the terms or limitations of this warranty in any way.

WARRANTY TERMS TABLE

NOTE: If your battery is not labeled with a warranty code, it is a warranty code 6.

Warranty Code	Free Replacement Period	Pro Rata Warranty Period
A	90 Days	40 Months
B	90 Days	36 Months
C	90 Days	24 Months
D	12 Months	48 Months
E	90 Days	12 Months
F	90 Days	60 Months
G	12 Months	60 Months
H	12 Months	60 Months
6	6 Months	0 Months
12	12 Months	0 Months
18	18 Months	0 Months

OUMX068,0000504-19-10MAY17

Warranty

John Deere Quality Statement

John Deere Quality

John Deere equipment is more than just a purchase, it's an investment in quality. That quality goes beyond our equipment to your John Deere dealer's parts and service support. This support is needed to keep you a satisfied customer.

That's why John Deere has initiated a process to handle your questions or problems, should they arise. The following three steps will help guide you through the process.

Step 1

Refer to your operator's manual

- A. It has many illustrations and detailed information on the safe and proper operation of your equipment.
- B. It gives troubleshooting procedures, and specification information.
- C. It gives ordering information for parts catalogs, service and technical manuals.
- D. If your questions are not answered in the operator's manual, then go to Step 2.

Step 2

Contact your dealer

- A. Your John Deere dealer has the responsibility, authority, and ability to answer questions, resolve problems, and fulfill your parts and service needs.
- B. First, discuss your questions or problems with your dealer's trained parts and service staff.
- C. If the parts and service people are unable to resolve your problem, see the dealership manager or owner.
- D. If your questions or problems are not resolved by the dealer, then go to Step 3.

Step 3

Contact John Deere

- A. Your John Deere dealer is the most efficient source in addressing any concern, but if you are not able to resolve your problem after checking your operator's manual and contacting your dealer, contact John Deere for assistance.
- B. For prompt, effective service, please have the following ready before you call:
 - The name of the dealer with whom you've been working.
 - Your equipment model number.
 - Number of hours on machine (if applicable).
 - Your serial number which you recorded on the inside front cover of this manual.
 - If the problem is with an attachment, your attachment identification number.

C. Then call 1-800-537-8233 (United States and Canada) and our advisor will work with your dealer to investigate your concern. If you are outside the United States and Canada, visit the following website:

http://www.deere.com/globalhome/deerecom/global_home.page?CC=true

Select your country and then click on the Contact Us link.

SP66632,00043A7-19-10MAY17

Index

A	
Accessory Outlet, Using	39
Adjustment, Altitude	54
Air cleaner, replacing	56
Air intake, servicing	56
Alarm, Backup	49
B	
Battery and Terminals, Cleaning	71
Battery, Checking the	70
Battery, Removing and Installing	70
Battery, service safely	70
Battery, Using Booster	71
Bench Seat Fold Down Rack, Using	34
Boots, Steering Tie Rod, Inspecting	64
Brake Fluid, Checking	68
Brake Pads, Checking	68
Brakes, Troubleshooting	84
Bulb, Replacing Headlight	71
Bulb, Replacing Tail Light	73
C	
Cargo Box Latches, Adjusting	79
Cargo Box, Cleaning and Repairing	77
Cargo Box, Emptying	45
Cargo Box, Loading	44
Cargo Box, Removing and Installing	77
Cargo Box, Troubleshooting	84
Cargo box, using	41
Cargo rack, using	34
Chains, Tire, Using	46
Clutches, servicing	65
Controls, Operator	32
CV Boots, Checking	64
D	
Drive belt	
Replacing	65
Servicing	65
Drive Line, Lubricating	53
Dust unloading valve, cleaning	57
E	
Electrical, Troubleshooting	84
Electronic display, use properly	28
Emergency Stopping	41
Engine	
Oil	54
Engine, Cleaning	57
Engine, Starting the	40
Engine, Stopping	41
Engine, Troubleshooting	83
F	
Fluid, Brake	68
Four wheel drive, using	37
Front Differential Oil 4WD, Changing	62
Front Differential Oil 4WD, Checking	62
Front Differential Oil, 4WD	62
Fuel and Stabilizer, Using Proper	74
Fuel Filter, Replacing	59
Fuel safety	28
Fuel Storage	85
Fuel tank, filling	74
Fuses, Replacing	72
G	
Grease	53
H	
Hand holds, using	
Bench seat	34
Bucket seat	33
Hazard Lights, Using	39
Headlights, using	38
Hitch, Front Receiver	50
Hood, Opening and Closing	76
Horn	49
I	
Instrument Display, Using	38
K	
Key Switch, Using	38
L	
Labels, safety no-text	17
Labels, safety text	9
Lifting machine	75
Load capacity	43
Loads, Towing	45
M	
Metal Surfaces, Repairing and Cleaning	81
N	
Nets	
Servicing	77
Using	33
Nets or doors, inspecting	77
O	
Oil	
Engine	
Gasoline.....	54
Oil, engine	
Changing oil and filter	55
Checking level	55
Oil, Transaxle	62

Index

Oil, Transaxle, Changing	63
Operating Checklist, Daily	33

P

Park Brake, Adjusting	69
Park brake, using	36
Parking Safely	22
Plastic And Painted Surfaces, Avoid Damage To	33
Plastic hood and body panel surfaces, cleaning	81
Plastic Surfaces, Cleaning	80

Q

Quick Clamps, Using	48
---------------------------	----

R

Rear lock, using	37
Rear screen	49
Record service dates	97
Replacement parts	2

S

Safety labels, no-text	17
Safety labels, text	9
Safety Start System, Testing	36
Safety Systems, Testing	36
Safety, tire	27
Seat belt, inspecting	76
Seat belt, using	35
Seat, adjusting	34
Service Information, Emissions	54
Service Intervals	51
Service Safety	26
Servicing, your machine	51
Spark Arrestor, Checking	60
Spark Arrestor, Using	22
Spark plug, checking	58
Storage trays, using	39
Storage, Preparing Machine for	85, 86
Storing Safety	85
Suspension, lubricating	53
Suspension, Standard Shocks, Adjusting	80

T

Tire Rack, Using	50
Tires, Inflation	46
Toe- In, Checking and Adjusting	79
Transaxle, Checking Oil	63
Transporting machine	46
Travel controls, using	36
Troubleshooting chart	83
Turn Signal Switch, Using	39

W

Warranty, product	90
Wheel Assembly, Removing and Installing	75
Windshield, maintenance	82

Notes
