

XUV865E, XUV865M, XUV865R Gator™ Utility Vehicle

(Serial No. 010001 -)



JOHN DEERE

OPERATOR'S MANUAL

Gator™ Utility Vehicle XUV865E,
XUV865M, XUV865R

OMUC13637 ISSUE 18 (ENGLISH)

CALIFORNIA

Proposition 65 Warning

Diesel engine exhaust and some of its constituents are known to the State of California to cause cancer, birth defects, and other reproductive harm.

If this product contains a gasoline engine:

WARNING

The engine exhaust from this product contains chemicals known to the State of California to cause cancer, birth defects or other reproductive harm.

The State of California requires the above two warnings.

Additional Proposition 65 Warnings can be found in this manual.

John Deere Horicon Works

North American Edition
PRINTED IN U.S.A.



* D C Y *



* 0 M U C 1 3 3 6 3 7 *

Introduction

Thank You for Purchasing a John Deere Product

We appreciate having you as a customer and wish you many years of safe and satisfied use of your machine.

MX00654,000020B-19-10MAY17

Using Your Operator's Manual

This manual is an important part of your machine and should remain with the machine when you sell it.

Reading your operator's manual will help you and others avoid personal injury or damage to the machine. Information given in this manual will provide the operator with the safest and most effective use of the machine. Knowing how to operate this machine safely and correctly will allow you to train others who may operate this machine.

If you have an attachment, use the safety and operating information in the attachment operator's manual, along with the machine operator's manual, to operate the attachment safely and correctly.

This manual and safety signs on your machine may also be available in other languages (see your authorized dealer to order).

Sections in your operator's manual are placed in a specific order to help you understand all the safety messages and learn the controls so you can operate this machine safely. You can also use this manual to answer any specific operating or servicing questions. A convenient index located at the end of this book will help you find needed information quickly.

The machine shown in this manual may differ slightly from your machine, but will be similar enough to help you understand our instructions.

RIGHT-HAND and LEFT-HAND sides are determined by facing in the direction that the machine will travel when going forward. When you see a broken line (-----), the item referred to is hidden from view.

Before delivering this machine, your dealer performed a predelivery inspection to ensure best performance.

MX00654,000020C-19-05JUN17

Special Messages

Your manual contains special messages to bring attention to potential safety concerns and machine damage, as well as helpful operating and servicing information. Please read all the information carefully to avoid injury and machine damage.

 **CAUTION: Avoid injury! This symbol and text highlight potential hazards or death to the operator or bystanders that may occur if the hazards or procedures are ignored.**

IMPORTANT: Avoid damage! This text is used to tell the operator of actions or conditions that might result in damage to the machine.

NOTE: General information is given throughout the manual that may help the operator in the operation or service of the machine.

MX00654,000020D-19-05JUN17

Attachments for Your Machine

There is a John Deere attachment or kit to make your new machine perform more tasks or be more versatile, whether your machine is a lawn tractor, compact utility tractor, or a utility vehicle.

You can check out the entire line of attachments for your machine at JohnDeere.com or ask your John Deere dealer. From aerators to electric lift kits to tillers, there is a John Deere attachment or kit to fill every need.

OUMX068,000051C-19-05JUN17

Service Literature

If you would like to purchase a copy of the Parts Catalog or Technical Manual for this machine, visit The John Deere Technical Information Store at:

https://techpubs.deere.com/?cid=VURL_TechInfoStore

or call:

- **U.S. & Canada:** 1-800-522-7448.
- **All Other Regions:** Your John Deere dealer.

TH84124,0000199-19-15AUG17

Parts

We recommend John Deere quality parts and lubricants, available at your John Deere dealer.

When you order parts, your John Deere dealer needs the serial number or product identification number (PIN) for your machine or attachment. These are the numbers that you recorded in the Product Identification section of this manual.

Order Service Parts Online

Visit <http://JDParts.deere.com> for your Internet connection to parts ordering and information.

TC00531,00000E9-19-06MAR15

Contents

Product Identification.....	4
Safety Labels with Text.....	5
Safety Labels without Text.....	10
Safety.....	15
Machine Cleanout.....	24
Operating Controls.....	26
Operating.....	27
Optional Attachments & Kits.....	48
Service Intervals.....	50
Service Lubrication.....	51
Service Engine.....	52
Service Transmission.....	66
Service Steering & Brakes.....	74
Service Electrical.....	77
Service Miscellaneous.....	85
Troubleshooting.....	94
Storage.....	98
Specifications.....	101
Warranty.....	105
John Deere Quality Statement.....	110
Service Record.....	112

Original Instructions. All information, illustrations and specifications in this manual are based on the latest information available at the time of publication. The right is reserved to make changes at any time without notice.

COPYRIGHT © 2018
DEERE & COMPANY
Moline, Illinois
All rights reserved.
Previous Editions
Copyright © 2017

Product Identification

Record Identification Numbers

XUV865

PIN (010001-)

Contact an Authorized Service Center for information on servicing. Always provide the product model and identification numbers.

Locate the identification numbers for the product. Record the information in the spaces provided.



MXT018939—UN—29NOV16

Located on frame behind right front wheel.

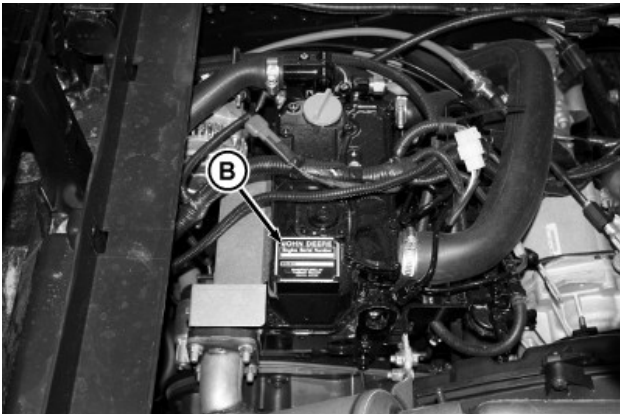

MXT018940—UN—28NOV16



MXT018941—UN—28NOV16

DEALER NAME:

DEALER PHONE:

PRODUCT IDENTIFICATION NUMBER (A):

ENGINE SERIAL NUMBER (B):

OPTIONAL ELECTRIC POWER ASSIST STEERING (EPAS) SERIAL NUMBER (C):

SB31882.000027D-19-31AUG18

DATE OF PURCHASE:

Safety Labels with Text

Safety Label Location

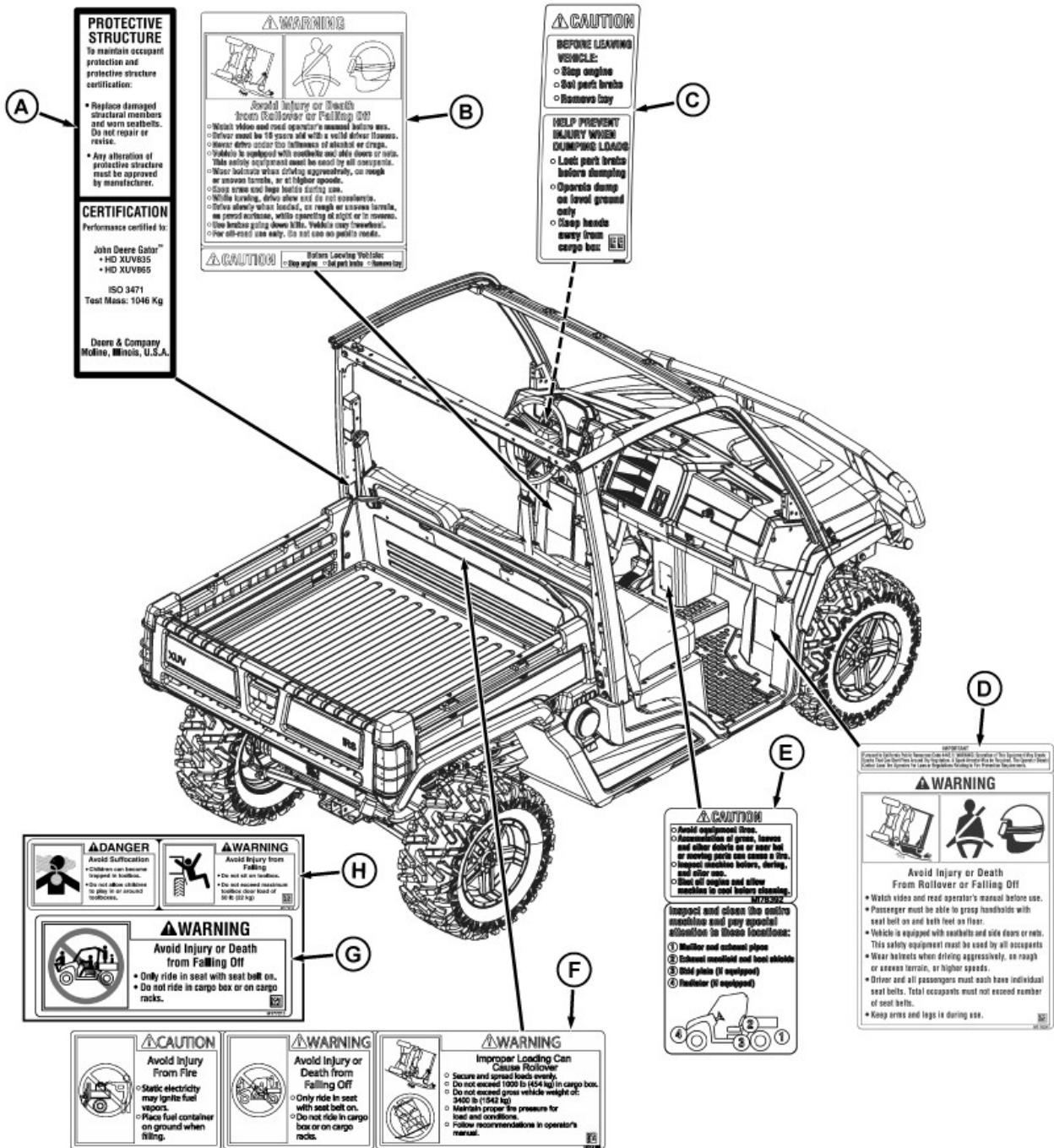

A—Protective Structure Label - M178524 or UC13885
B—WARNING - M178390
C—CAUTION - M178438
D—WARNING - M178391

E—CAUTION - M178392
F—WARNING - UC14189
G—WARNING - M177213 (Installed on optional toolbox)
H—WARNING - M177212 (Installed on optional toolbox)

MXT018928—UN—08SEP17

OUMX068,00011D8-19-08SEP17

Safety Labels with Text

Understanding the Machine Safety Labels



MXAL42363—UN—22MAY13

The machine safety labels shown in this section are placed in important areas on your machine to draw attention to potential safety hazards. DANGER or WARNING safety labels are located near specific hazards.

The operator's manual also explains any potential safety hazards whenever necessary in special safety messages that are identified with the word, CAUTION, and the safety-alert symbol.

On your machine safety labels, the words DANGER, WARNING, and CAUTION are used with this safety-alert symbol. DANGER identifies the most serious hazards:

- DANGER; The signal word DANGER indicates a hazardous situation which, if not avoided, will result in death or serious injury.
- WARNING; The signal word WARNING indicates a hazardous situation which, if not avoided, could result in death or serious injury.
- CAUTION; The signal word CAUTION indicates a hazardous situation which, if not avoided, could result in minor or moderate injury. CAUTION may also be used to alert against unsafe practices associated with events which could lead to personal injury.

Replace missing or damaged safety labels. Use this operator's manual for correct safety label placement.

There can be more safety information contained on parts and components sourced from suppliers that is not reproduced in this operator's manual.

French or Spanish Safety Labels and Operator's Manual

Operator's manuals and safety labels with content in French or Spanish are available for this machine through authorized John Deere dealers. See your John Deere dealer.

NOTE: Both text and no-text labels are shown. Your machine is only equipped with one of these types of labels.

MP47322,00F4601-19-21JUN18

Protective Structure Safety and Certification Label

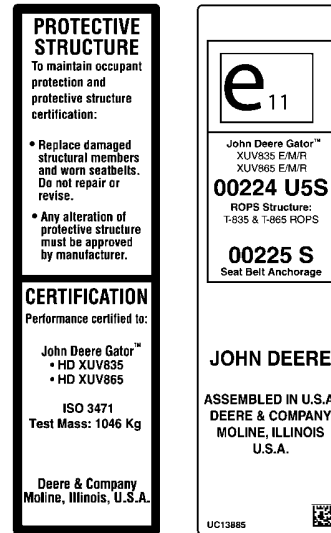

MXT020788—UN—31AUG17

One label is installed on your machine depending upon your region.

PROTECTIVE STRUCTURE

To maintain occupant protection and protective structure certification:

- Replace damaged structural members and worn seat belts. Do not repair or revise.
- Any alteration of protective structure must be approved by manufacturer.

CERTIFICATION

Performance certified to:

John Deere Gator™

- HD XUV835
- HD XUV865

ISO 3471

Test Mass: 1046 Kg

Deere & Company Moline, Illinois, U.S.A.

OUMX068,000123A-19-31AUG17

Safety Labels with Text

WARNING



MXT018929—UN—22NOV16

Avoid Injury or Death from Rollover or Falling Off

- Watch video and read operator's manual before use.
- Driver must be 16 years old with a valid driver license.
- Never drive under the influence of alcohol or drugs.
- Vehicle is equipped with seatbelts and side doors or nets. This safety equipment must be used by all occupants.
- Wear helmets when driving aggressively, on rough or uneven terrain, or at higher speeds.
- Keep arms and legs in during use.
- While turning, drive slow and do not accelerate.
- Drive slowly when loaded, on rough or uneven terrain, on paved surfaces, while operating at night or in reverse.
- Use brakes going down hills. Vehicle may freewheel.
- For off-road use only. Do not use on public roads.

CAUTION

Before Leaving Vehicle:

- Stop engine
- Set park brake
- Remove key

OUMX068,00011DA-19-22NOV16

CAUTION

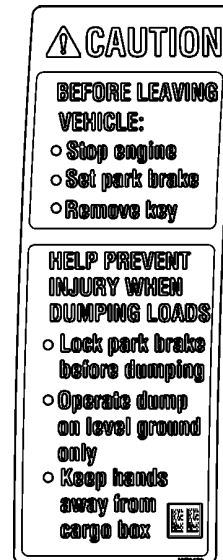

MXT018930—UN—22NOV16

BEFORE LEAVING VEHICLE:

- Stop engine
- Set park brake
- Remove key

HELP PREVENT INJURY WHEN DUMPING LOADS

- Lock park brake before dumping
- Operate dump on level ground only
- Keep hands away from cargo box

OUMX068,00011D9-19-22NOV16

Safety Labels with Text

WARNING

IMPORTANT
Pursuant to California Public Resources Code 4442.6: WARNING: Operation of This Equipment May Create Sparks That Can Start Fires Around Dry Vegetation. A Spark Arrestor May be Required. The Operator Should Contact Local Fire Agencies For Laws or Regulations Relating to Fire Prevention Requirements.

WARNING



Avoid Injury or Death From Rollover or Falling Off

- Watch video and read operator's manual before use.
- Passenger must be able to grasp handholds with seat belt on and both feet on floor.
- Vehicle is equipped with seatbelts and side doors or nets. This safety equipment must be used by all occupants
- Wear helmets when driving aggressively, on rough or uneven terrain, or higher speeds.
- Driver and all passengers must each have individual seat belts. Total occupants must not exceed number of seat belts.
- Keep arms and legs in during use.

M178381

MXT018931—UN—08SEP17

Important

Pursuant to California Public Resources Code 4442.6: WARNING: Operation of This Equipment May Create Sparks That Can Start Fires Around Dry Vegetation. A Spark Arrestor May be Required. The Operator Should Contact Local Fire Agencies For Laws or Regulations Relating to Fire Prevention Requirements.

Avoid Injury or Death from Rollover or Falling Off

- Watch video and read operator's manual before use.
- Passenger must be able to grasp handholds with seat belt on and both feet on floor.
- Vehicle is equipped with seatbelts and side doors or nets. This safety equipment must be used by all occupants.
- Wear helmets when driving aggressively, on rough or uneven terrain, or at higher speeds.
- Driver and all passengers must each have individual seat belts. Total occupants must not exceed number of seat belts.
- Keep arms and legs in during use.

OUMX068,00011DB-19-08SEP17

CAUTION

CAUTION

- Avoid equipment fires.
- Accumulation of grass, leaves and other debris on or near hot or moving parts can cause a fire.
- Inspect machine before, during, and after use.
- Shut off engine and allow machine to cool before cleaning.

M165718

Inspect and clean the entire machine and pay special attention to these locations:

- 1 Muffler and exhaust pipes
- 2 Exhaust manifold and heat shields
- 3 Skid plate (if equipped)
- 4 Radiator (if equipped)



MXAL44150—UN—10APR13

- Avoid equipment fires.
- Accumulation of grass, leaves and other debris on or near hot or moving parts can cause a fire.
- Inspect machine before, during, and after use.
- Shut off engine and allow machine to cool before cleaning.

Inspect and clean the entire machine and pay special attention to these locations:

1. Muffler and exhaust pipes
2. Exhaust manifold and heat shields
3. Skid plate (if equipped)
4. Radiator (if equipped)

MX00654,00000B1-19-24AUG13

WARNING

Avoid Injury From Fire

CAUTION

Avoid Injury From Fire

- Static electricity may ignite fuel vapors.
- Place fuel container on ground when filling.



MXAL44147—UN—10APR13

- Static electricity may ignite fuel vapors.
- Place fuel container on ground when filling.

Safety Labels with Text

Avoid Injury or Death from Falling Off



MXAL44145—UN—10APR13

- Only ride in seat with seat belt on.
- Do not ride in cargo box or on cargo racks.

Improper Loading Can Cause Rollover

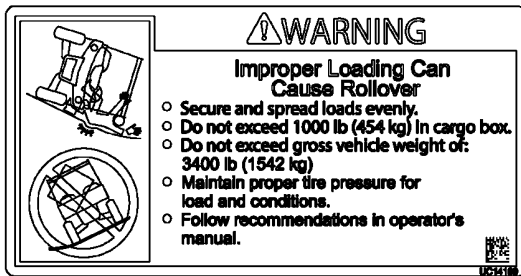

MXT021072—UN—24AUG17

- Secure and spread loads evenly.
- Do not exceed 1000 lb (454 kg) in cargo box.
- Do not exceed gross vehicle weight of: 3400 lb (1542 kg)
- Maintain proper tire pressure for load and conditions.
- Follow recommendations in operator's manual.

MX10673.0000028-19-28AUG17

WARNING



MXT015589—UN—15SEP15

Avoid Injury or Death from Falling Off

- Only ride in seat with seat belt on.
- Do not ride in cargo box or on cargo racks.

OOU2004.0000CF1-19-17SEP15

DANGER



MXT018932—UN—22NOV16

Avoid Suffocation

- Children can become trapped in toolbox.
- Do not allow children to play in or around toolboxes.

OUMX068.00011DC-19-22NOV16

WARNING



MXT015594—UN—17SEP15

Avoid Injury from Falling

- Do not sit on toolbox.
- Do not exceed maximum toolbox door load of 50 lb (22 kg)

OOU2004.0000CF7-19-17SEP15

Safety Labels without Text

Safety Label Location

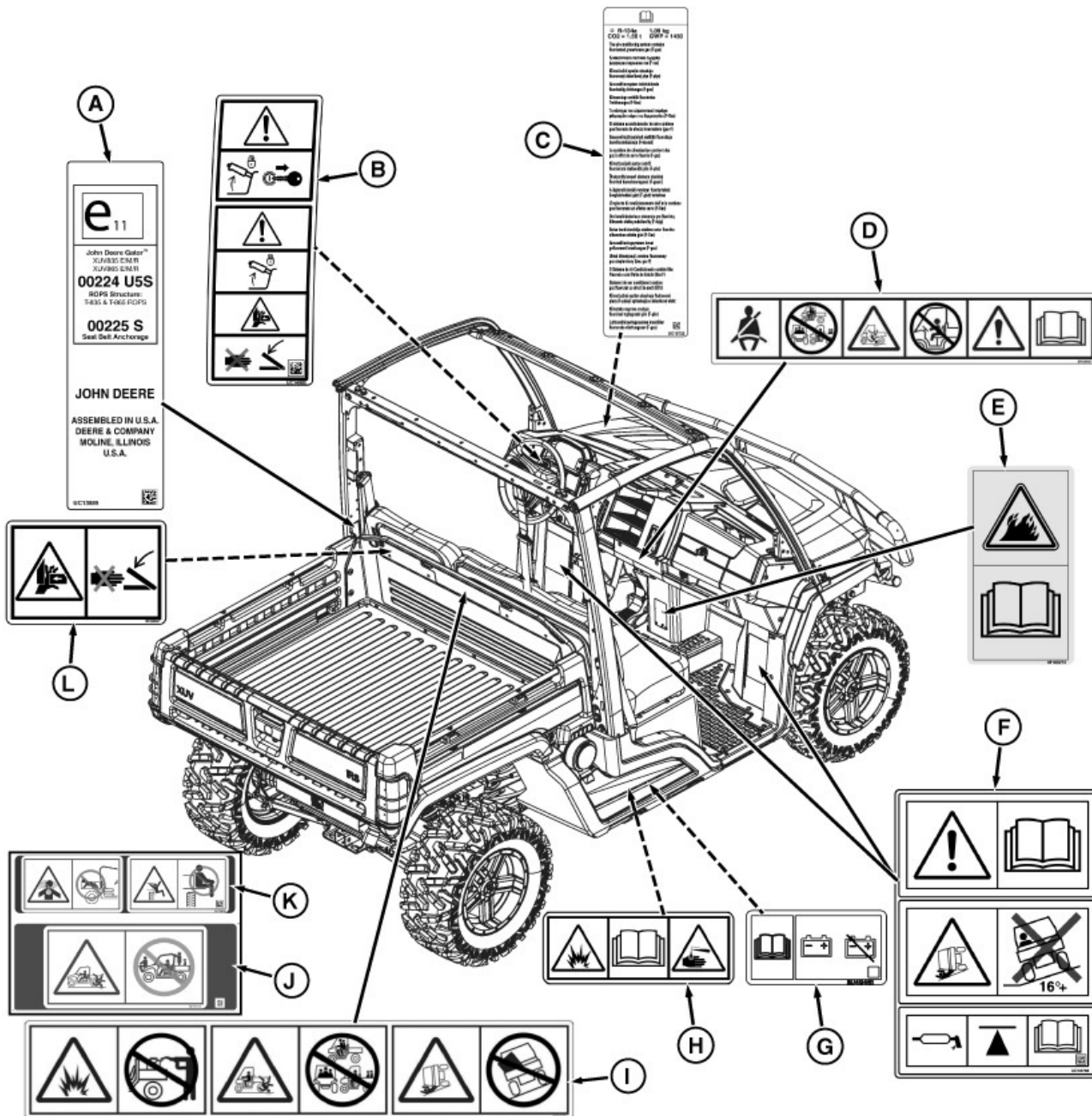

MXT020777—UN—13SEP17

- A—Protective Structure Label - M178524 or UC13885
- B—Help Prevent Injury When Dumping Loads - UC14900
- C—Flourinated Greenhouse Gas Label - UC16732
- D—Driver and Passenger Safety - M159667
- E—Avoid Injury From Equipment Fires - M165273
- F—Read Operator's Manual, Avoid Tipping - UC12756
- G—Read Operator's Manual, Service Battery - SU49461
- H—Avoid Injury From Battery Gases and Acid - M133159

- I—Avoid Injury From Explosion, Riders Can Fall Off and Be Killed, Rollover or Falling Off May Cause Death - M161570
- J—Avoid Injury or Death from Falling Off - M176918 (Installed on optional toolbox)
- K—Avoid Suffocation - Avoid Injury from Falling - M176639 (Installed on optional toolbox)
- L—Avoid Injury from Crushing - M120057

MX10673.000008D-19-13SEP17

Safety Labels without Text

Understanding the Machine Safety Labels without Text



TCT005498—UN—11SEP12

At several important places on this machine, safety signs are affixed which signify potential danger. The hazard is identified by a pictorial in a warning triangle. An adjacent pictorial provides information on how to avoid personal injury. These safety signs, their placement on the machine, and a brief explanatory text are shown in this Safety section.

There can be additional safety information contained on parts and components sourced from suppliers that is not reproduced in this operator's manual.

MX00654.0000389-19-21JUN18

- HD XUV835
- HD XUV865

ISO 3471

Test Mass: 1046 Kg

Deere & Company Moline, Illinois, U.S.A.

OUMX068.000123A-19-31AUG17

Help Prevent Injury When Dumping Loads



MXT020775—UN—28AUG17

Protective Structure Safety and Certification Label

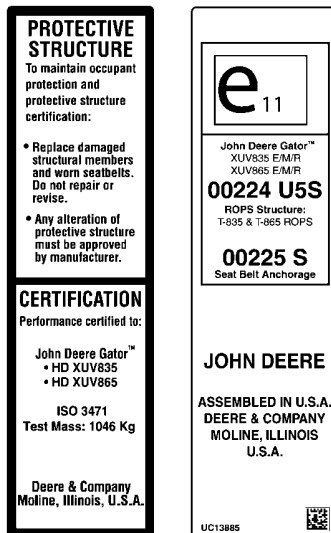

MXT020788—UN—31AUG17

One label is installed on your machine depending upon your region.

BEFORE LEAVING VEHICLE:

- Stop engine
- Set park brake
- Remove key

HELP PREVENT INJURY WHEN DUMPING LOADS

- Lock park brake before dumping
- Operate dump on level ground only
- Keep hands away from cargo box

OUMX068.000136F-19-28AUG17

PROTECTIVE STRUCTURE

To maintain occupant protection and protective structure certification:

- Replace damaged structural members and worn seat belts. Do not repair or revise.
- Any alteration of protective structure must be approved by manufacturer.

CERTIFICATION

Performance certified to:

John Deere Gator™

Safety Labels without Text

Fluorinated Greenhouse Gas

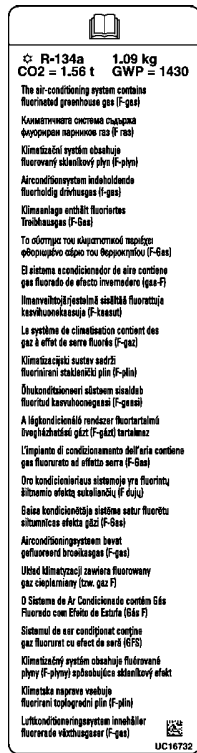

MXT020787—UN—30AUG17

R-134a 1.09 kg
CO₂ = 1.56 t GWP = 1430

The air-conditioning system contains fluorinated greenhouse gas (F-gas)

OUMX068,0001371-19-30AUG17

Driver and Passenger Safety

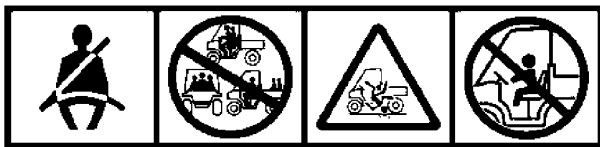

MXT008450—UN—27AUG13

Avoid Serious Injury or Death

- Driver must be at least 16 years old with a valid driver license.
- Driver and all passengers must each have individual seat belts. Total occupants must not exceed number of seat belts.
- Passenger must be able to grasp handholds with seat belt on and both feet on floor.

Young Drivers Increase Chance of Death

- Young drivers may not be able to control vehicle.

- No drivers younger than 16 years old.

MX10673,0000059-19-13SEP17

Read Operator's Manual

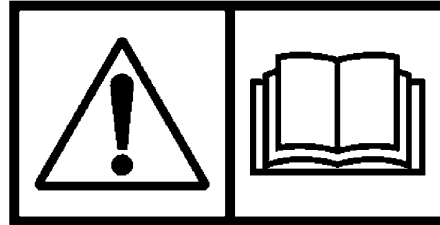

MXAL42776—UN—09APR13

- This operator's manual contains important information necessary for safe machine operation.
- Carefully read operator's manual before operating machine or attachment. Observe all safety rules to avoid accidents.

MX00654,000038B-19-15JUN16

Avoid Injury From Equipment Fires

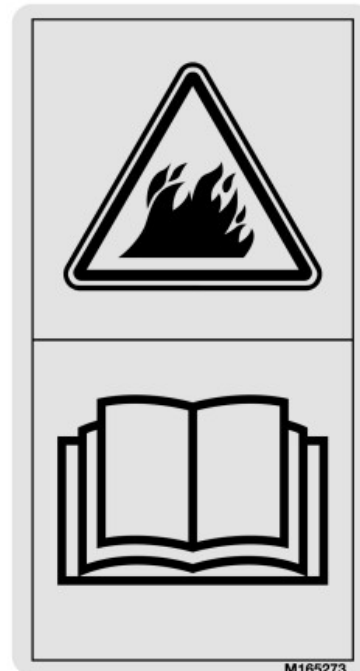

M165273

MXT010007—UN—13MAY14

- Avoid equipment fires.
- Accumulation of grass, leaves and debris on or near hot or moving parts can cause a fire.
- Inspect and clean the entire machine before, during and after use.
- Shut off engine and allow machine to cool before cleaning.

Safety Labels without Text

- Carefully read Operator's Manual Machine Clean out section for details.

OUMX068,0000027-19-08JUL16

Avoid Injury From Tipping

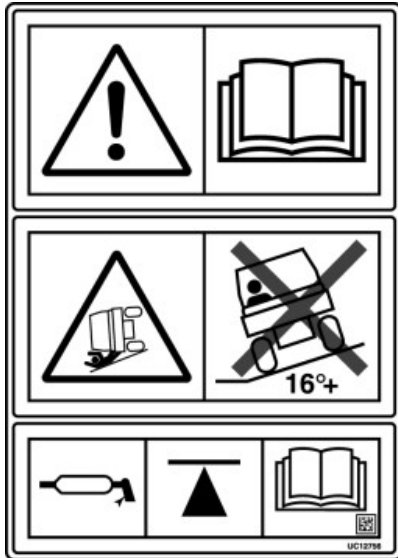

MXT020262—UN—05JUL17

- Read operator's manual.
- Drive slowly when turning.
- Always use brakes going down a slope. Vehicle can takeoff (freewheel) downhill.
- No loads heavier than 1000 lb (454 kg). Spread load evenly. Tie loads down.
- Reduce speed and load, on rough or hilly ground.
- Maintain proper tire pressure for load and conditions.
- Do not exceed gross vehicle weight rating 3400 lb (1542 kg). Following loading instructions in operator's manual.
- Jacking point.

MX10673,0000082-19-09SEP17

Read Operator's Manual, Service Battery

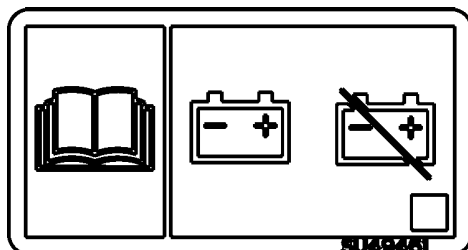

MXT020147—UN—16MAY17

- Read Operator's Manual
- Service Battery

OUMX068,0001296-19-16MAY17

Avoid Injury From Battery Gases and Acid

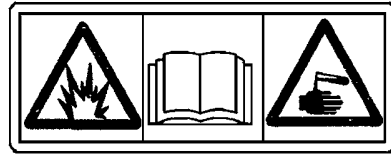

MXT007302—UN—23MAY13

- Shield eyes, explosive gases can cause blindness or injury.
- No sparks, flames, smoking.
- Sulfuric acid can cause blindness or severe burns.
- Keep out of the reach of children.
- Do not tip.
- Keep vent caps tight and level.
- Flush eyes immediately with water. Get medical help fast.

MX00654,0000394-19-21AUG14

Avoid Injury From Explosion

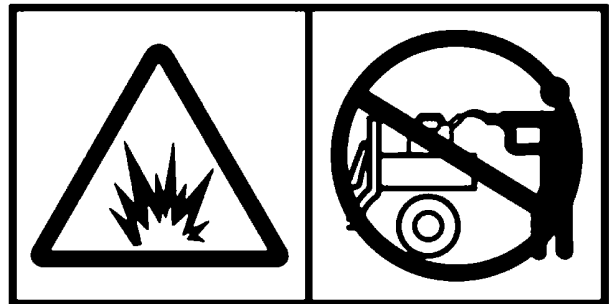

MXT008452—UN—27AUG13

- Do not place gas container inside cargo box bed when filling.
- Place gas container on ground when filling.

MX00654,00000D5-19-27AUG13

Riders Can Fall Off and Be Killed



MXT008453—UN—20JUL17

- Driver and all passengers must each have individual seat belts. Total occupants must not exceed number of seat belts.

Safety Labels without Text

- No riders in box or anywhere else.

MX10673,000008E-19-13SEP17

Rollover or Falling Off May Cause Death

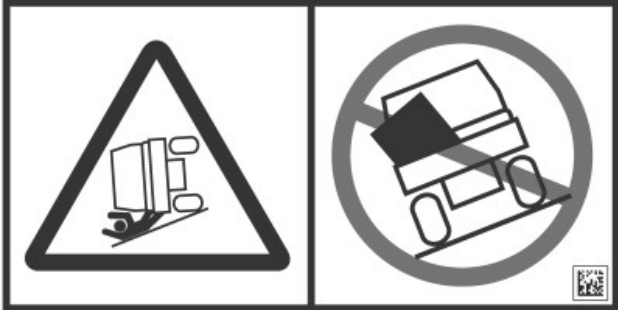

MXT008454—UN—20JUL17

- Read operator's manual.
- Drive very slowly when turning.
- Always use brakes going down a slope. Vehicle can takeoff (freewheel) downhill.
- Reduce speed and load on rough or hilly ground.

MX00654,00000D7-19-27AUG13

Avoid Injury or Death from Falling Off

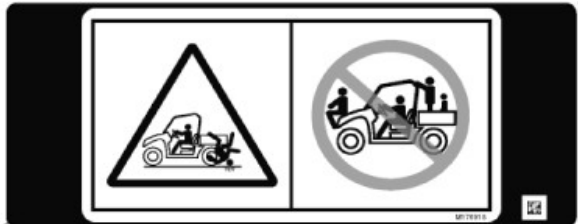

MXT015591—UN—15SEP15

- Only ride in seat with seat belt on.
- Do not ride in cargo box or on cargo racks.

OOU2004,0000CF4-19-17SEP15

Avoid Suffocation

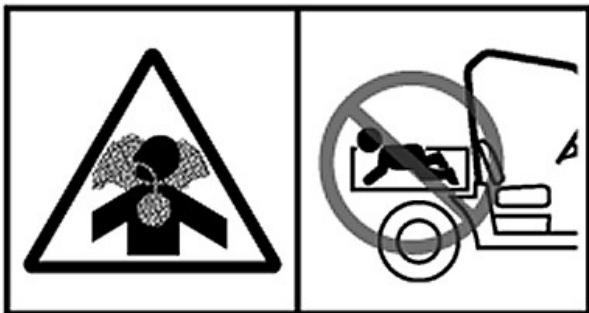

MXT015955—UN—17SEP15

- Children can become trapped in toolbox.

- Do not allow children to play in or around toolboxes.

OOU2004,0000CF3-19-17SEP15

Avoid Injury from Falling



MXT015956—UN—17SEP15

- Do not sit on toolbox.
- Do not exceed maximum toolbox door load of 50 lb (22 kg)

OOU2004,0000CF8-19-17SEP15

Avoid Injury from Crushing

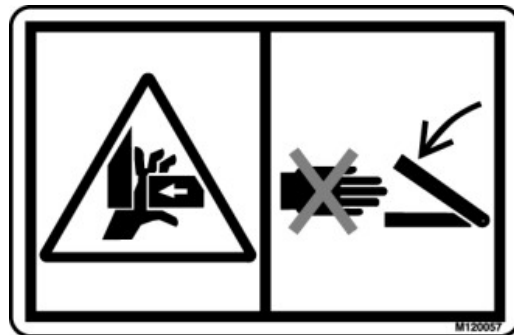

MXT020263—UN—05JUL17

- Avoid crushing injury.
- Keep hands away from cargo box.

OUMX068,0001315-19-05JUL17

Safety

Supervisor Safety Responsibilities

- Make sure all operators of this machine are thoroughly trained and are familiar with the operator's manual and understand the machine warning labels.
- Be sure to establish any special safety procedures for existing work conditions and train operators in those procedures.
- Supervisors, operators and mechanics should be familiar with and practice the safety standards that apply to this machine.

RH75544,0000159-19-08APR13

Operator Training Required

- Read the operator's manual and other training material. If the operator or mechanic cannot read English, it is the owner's responsibility to explain this material to them. This publication is available in other languages.
- Become familiar with the safe operation of the equipment, operator controls, and safety signs.
- All operators and mechanics should be trained. The owner of the machine is responsible for training the users.
- Never let children or untrained people operate or service the equipment. Local regulations may restrict the age of the operator.
- The owner/user can prevent and is responsible for accidents or injuries occurring to themselves, other people, or property.
- Operate the machine in an open, unobstructed area under the direction of an experienced operator when training.

RH75544,000015A-19-03APR18

Operating Safely

- Read, understand, and follow all instructions in the operator's manual, on the machine, and on the safety video before starting.
- Misuse can lead to accidents, severe bodily injury, or death.
- The utility vehicle's tires are designed for off-road use only. Paved surfaces may seriously affect handling and control of the vehicle. If you must operate on a paved surface, travel slowly and do not make sudden turns or stops.
- Do not operate this vehicle on a frozen body of water. The vehicle could break through the ice, causing injury or even death.
- Go slowly and be extra careful when riding on snow-covered or ice-covered terrain.
- Slow down and be careful of traffic when operating near or crossing roadways. Use care when

approaching blind corners, shrubs, trees, or other objects that may obscure vision.

- The operator should always make sure that the passenger is aware of correct safety procedures while riding in the utility vehicle.
- Use the correct flags, lights, signs, and reflectors on the vehicle to warn other drivers when operating near roadways. Make sure these features are clean and visible for 152 m (500 ft.).
- The passenger should always use the hand holds.
- On machines with seat belts, to avoid serious injury, always ensure that occupants have safely secured their seat belts prior to starting this vehicle.
- Horseplay can lead to accidents, severe bodily injury, or death. Do not attempt stunts, jumps, or quick acceleration to raise front wheels off the ground. These actions can result in accidents or vehicle overturns.
- Sit on the center of the seat and keep both feet within the foot platform perimeter. Clean foot platform if dirty, and remove any debris from around foot controls.
- Check for debris in engine compartment, especially around exhaust system components.
- Always use both hands for steering.
- Know location of controls and how and what they operate.
- Never operate utility vehicle while standing.
- Never operate utility vehicle with the cargo box raised.
- Check brake action before beginning vehicle operation. Adjust or service the brakes as necessary.
- To provide adequate braking ability and traction, do not tow any attachment or loaded trailer unless the cargo box is fully loaded.
- Do not allow the Gross Vehicle Weight (GVW) to exceed the Gross Vehicle Weight Rating (GVWR) of the vehicle.
- Before shifting into reverse, always check for obstacles or people behind the machine.
- Always back slowly.
- Inspect vehicle before operating. Be sure hardware is tight. Repair or replace damaged, badly worn, or missing parts. Be sure guards and shields are in good condition and fastened in place. Make any necessary adjustments before operating.
- Do not leave vehicle unattended when it is running.
- Operate during daylight or with good artificial light, and if you drive at night, use the lights.
- Do not operate vehicle if under the influence of alcohol or other drugs.
- Avoid sudden starts, stops, or turns.
- Always use a level turn-around area.

Safety

- Do not wear radio or music headphones. Safe service and operation require your full attention.

OUMX068,000094A-19-05JUL17

Using a Spark Arrestor

The California Public Resources Code, section 4442.5 provides as follows:

No person shall sell, offer for sale, lease, or rent to any person any internal combustion engine subject to Section 4442 or 4443, and not subject to Section 13005 of the Health and Safety Code, unless the person provides a written notice to the purchaser or bailee, at the time of sale or at the time of entering into the lease or rental contract, stating that it is a violation of Section 4442 or 4443 to use or operate the engine on any forest-covered, brush-covered, or grass-covered land unless the engine is equipped with a spark arrestor, as defined in Section 4442, maintained in effective working order or the engine is constructed, equipped, and maintained for the prevention of fire pursuant to Section 4443. Cal. Pub. Res. Code 4442.5.

Other states or jurisdictions may have similar laws. A spark arrestor for your machine may be available from your authorized dealer. An installed spark arrestor must be maintained in good working order by the operator.

RH75544,000015C-19-08APR13

Parking Safely

1. Stop vehicle on a level surface, not on a slope.
2. Fully lower the cargo box and any attachments on the machine that can be lowered.
3. Fully engage park brake and ensure vehicle is not moving.
4. Stop engine.
5. Remove key.
6. Before you leave the operator's seat, wait for engine and all moving parts to stop.
7. Disconnect the negative battery cable before servicing the machine.

OUMX068,00005F5-19-09AUG18

Protect Children/Small Adults and Prevent Accidents

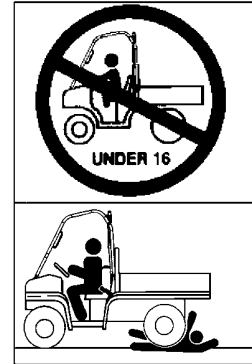

MXAL43278—UN—15MAR13

- This utility vehicle should not be operated by anyone under the age of 16 years.
- This utility vehicle should not be operated by anyone without a valid driver license.
- Young drivers may not be physically able to control the machine or may not be mature enough to make safe driving decisions.
- Do not allow children to ride as a passenger in this vehicle. Children may not be able to sit safely in the passenger seat and use handholds properly. Passengers must be able to grasp handholds with their back against the seat, seat belt on, and both feet on the floor.
- Passenger should always use the handholds while the vehicle is moving.
- Seat belts installed on utility vehicles are not designed to restrain children.
- Never carry passengers, especially children, in the cargo box area. Do not tow children in a cart or trailer.
- Never assume that children remain where you last saw them. Stay alert to the presence of children.
- Before backing or turning, look behind and around the utility vehicle for children.
- Be alert at all times, drive forward and in reverse carefully. People, especially children, can move quickly into an area of operation.
- Use extra care when coming to blind corners, shrubs, trees, or other objects that may block vision.
- Misuse and reckless riding can lead to accidents, severe bodily injury, or death.

OUCO2005,0000169-19-16AUG18

Avoid Excessive Speeds

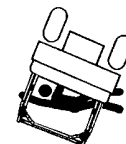

MXAL43279—UN—15MAR13

- Always wear an approved helmet when operating the

Safety

vehicle in an aggressive manner, on rough or uneven terrain, or at higher speeds.

- Always travel at a speed that is safe and proper for the terrain, visibility and operating conditions, and your experience operating the machine.
- Use caution when operating the machine in reverse. Use a slow speed and do not make sharp turns. Always look behind before backing.
- Never travel at excessive speeds on slopes, either going up or down. Use a slow speed and do not make sharp turns. Become experienced driving the machine on small slopes before driving on larger hills.

MX00654,00000B4-19-27APR18

Avoid Tipping

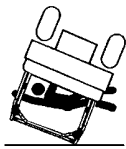

MXAL43279—UN—15MAR13

Accidents resulting in serious injury or death can occur from tipping the utility vehicle. Observe the following practices to help prevent accidents and always wear an approved helmet when operating the vehicle in an aggressive manner, on rough or uneven terrain, or at higher speeds.

- Drive very slowly when turning. Sharp turns could cause the utility vehicle to tip over.
- Reduce speed and exercise extreme caution on slopes or on rough ground.
- Do not overload vehicle and avoid shifting loads. Reduce load when operating over rough or hilly terrain.
- Do not stop or start suddenly when going uphill or downhill. Be especially cautious when changing direction on slopes.
- Stay alert for holes, rocks, and other hidden hazards in the terrain.
- Keep away from drop-offs, ditches, embankments, as well as ponds and other bodies of water. The machine could suddenly roll over if a wheel goes over the edge of a cliff or ditch or if the edge caves in.
- Keep front wheels straight at crest of hill or going over bumps.
- When descending a hill, remove foot from accelerator pedal and apply brakes to reduce speed and maintain control.
- Do not make unauthorized changes or modifications to the utility vehicle.
- This list of potential overturning hazards is not exhaustive.

MX00654,00000B5-19-27APR18

Use Seat Belts, Nets and Doors Properly



MXT008507—UN—10JAN17

- This vehicle is equipped with a seat belt alarm. The alarm will sound and an indicator will be displayed on the instrument cluster if the driver's seat belt is not fastened when the machine is traveling at a speed above 24 km/h (15 mph).
- Use a seat belt and doors or nets, if equipped, to minimize chance of injury from an accident, such as an overturn.
- Do not operate machine with any portion of the operator safety system inoperative or removed.
- Inspect seat belts, nets and doors for proper operation before each machine use.
- Insert metal tab of net, if equipped, into buckle until it clicks, indicating it is latched. Pull back on net to confirm it is securely latched.
- Layers of heavy clothing can interfere with proper positioning of the seat belt and can reduce the effectiveness of the seat belt.
- Never modify, disassemble, or attempt to repair a seat belt, nets or doors.
- Inspect seat belts, nets and doors, if equipped, at least once a year. Look for signs of loose hardware or material damage, such as cuts, fraying, extreme or unusual wear, or abrasion. Replace only with John Deere approved replacement parts.
- Replace entire seat belt if mounting hardware, buckle, belt, or retractor show signs of damage.

MX10673,00000F9-19-19DEC17

Keep Protective Structure Installed Properly

- Never operate the machine without the Protective Structure installed.
- If the Protective Structure is loosened or removed for any reason, make certain all parts of the Protective Structure are installed correctly. All Protective Structure hardware must be tightened to the proper torque per manufacturer recommendations.
- Any alteration of the Protective Structure must be approved by the manufacturer. The protection provided by the Protective Structure can be impaired if the Protective Structure is subjected to structural damage, is involved in an overturn incident, or is in any way altered by welding, bending, drilling, or cutting.

Safety

- Never attempt to repair a damaged or altered Protective Structure. It must be replaced to maintain the manufacturer certification of the structure.

MX00654,00000B6-19-06NOV15

Keep Riders Off Vehicle



MXT008506—UN—10JAN17

- Seating is provided for operator and one or two front seat passengers when equipped with bench seat. When equipped with bucket seats, seating is provided for operator and one front seat passenger. All passengers must be able to grasp handholds with seat belt on and both feet on the floor.
- Never allow riders in the cargo box or other areas where seats are not provided.
- Riders on vehicle are subject to injury such as being struck by foreign objects or being thrown off of the vehicle and severely injured or killed.
- Riders affect the operator's ability to control the vehicle as well as its center of gravity. Also, riders could obstruct the operator's view resulting in the vehicle being operated in an unsafe manner.

MK71445,0000033-19-30MAY18

Before Driving

1. Perform Daily Operating Checklist in Operating section.
2. Clean foot platform if dirty, and remove any debris from around foot controls. Sit on the center of seat and keep both feet inside foot platform perimeter.
3. Inspect utility vehicle for signs of wear or damage.
4. All safety equipment must be in good condition and fastened in place:
 - Lights
 - Shields
 - Safety start devices
5. Before moving, check around utility vehicle, be sure no one is near it.
6. Inspect mechanical condition of your vehicle before each use to minimize chance of injury or being stranded. Remember, you can ride farther in an hour than you can walk in a day.

Be sure to check condition of tires and wheels, wheel hardware torque, and maintain proper tire pressure.

7. Securely anchor all loads.

MX00654,00000B8-19-27APR18

Transport Loads Safely

- Be sure load is evenly distributed in cargo box.
- Do not load above load guard.
- Securely anchor all loads in cargo box.
- Reduce cargo box load when operating on rough or hilly terrain.

MX00654,00000B9-19-24AUG13

Using Front Attachments

Remove front attachments such as drawbar hitches, hitch mounted winches, or blades when operating on rough or uneven terrain. Front attachments may contact the ground when operating on rough or uneven terrain which may cause loss of control or rollover.

OUMX068,0000634-19-22SEP16

Towing Loads Safely With Utility Vehicle

- To provide adequate braking ability and traction, the weight of towed load (trailer plus cargo) must never exceed the vehicle payload.
- Do not tow a load that exceeds the maximum allowable towing load for this vehicle, as specified in this operator's manual.
- Stopping distance increases with speed and weight of towed load. Travel slowly and allow extra time and distance to stop.
- Tow load at a speed slow enough to maintain control.
- Excessive towed load can cause loss of traction and loss of control on slopes. Reduce towed weight when operating on slopes.
- Never allow children or others in or on towed equipment.
- Use only approved hitches. Tow only with a machine that has a hitch designed for towing. Do not attach towed equipment except at the approved hitch point.
- Follow the manufacturer's recommendations for weight limits for towed equipment and towing on slopes.
- If you cannot back up a slope with a towed load, the slope is too steep to operate on with the towed load. Reduce the towed load or do not operate.
- Do not turn sharply. Use additional caution when turning or operating under adverse surface conditions. Use care when reversing.
- Do not shift to neutral and coast downhill.

Safety

- Secure towed loads before transporting.

OUMX068,000091B-19-25SEP17

Driving On Rough Terrain



MXAL43282—UN—15MAR13

- Always wear an approved helmet when operating the vehicle in an aggressive manner, on rough or uneven terrain, or at higher speeds.
- Use existing trails. Avoid terrain such as dangerous slopes and impassable swamps. Watch carefully for bumps, holes, ruts, loose terrain, or other obstacles.
- Look ahead at terrain. Know what is coming and be prepared to react. Be alert for hazards.
- Keep front wheels straight at crest of hill or going over bumps.
- Reduce speed according to trail, terrain, and visibility conditions.
- The passenger should always use the hand holds.

BB87125,0000D46-19-27APR18

Climbing or Descending a Hill or Slope

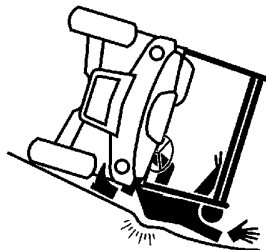

MXT008509—UN—10JAN17

- Always use the brakes when going down slopes. The utility vehicle can speed up (freewheel) going down a slope. Engine or clutch braking effect is minimal.
- Balance loads evenly and secure them. Braking could shift the load and affect vehicle stability.
- Sit on center of seat and keep both feet within foot platform.
- Never drive past the limit of visibility. Slow down near crest of hill until getting a clear view of the other side. Never go over the top of any hill at a high speed. An obstacle, sharp drop, another vehicle or person, could be on the other side of the hill.
- Keep front wheels straight at crest of hill or going over bumps.
- Do not stop or start suddenly when going uphill or downhill. Be especially cautious when changing direction on slopes.
- If vehicle stops or loses power going up a hill, lock

park brake to hold vehicle on slope. Maintain direction of travel and release brake slowly. Back straight down hill slowly while maintaining control. Do not turn vehicle sideways. Vehicle is more stable in a straight forward or rearward position.

- Always descend hill or slope at slow speeds and in a controlled manner. When descending a hill, remove foot from accelerator pedal and apply brakes to reduce speed and maintain control.
- The vehicle has a limited amount of engine braking that can assist when going down a hill or slope, but it is highly recommended to remove foot from throttle pedal and to use service brakes during descent as well.
- If the vehicle is freewheeling (engine braking is not engaged), use the service brakes to slow vehicle travel. Do not reengage engine braking (do not depress the throttle pedal) when freewheeling as that may cause the vehicle to skid.

RH75544,0000169-19-28FEB17

Driving Across Slopes

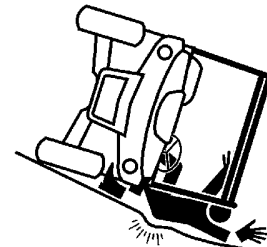

MXT008509—UN—10JAN17

- Reduce speed and use caution on slopes and in sharp turns.
- Stay alert for holes, rocks and other hidden hazards in the terrain.
- When riding on soft terrain, turn front wheels slightly uphill to keep utility vehicle on a straight line across the hill.
- If utility vehicle begins to tip, turn front wheel downhill to gain control before proceeding.

BB87125,0000D48-19-28FEB17

Riding Through Water

- Driving through water can contaminate the power train and electrical systems resulting in long-term vehicle damage.
- Your vehicle is capable of driving through still water in depth equal to the floorboard height.
- Never drive through deep or fast flowing water. The vehicle may become unstable and difficult to control.
- Never cross any body of water where depth may be unknown to the operator.
- If you must ride through water:

Safety

- Cross at a designated route if possible. Choose a course within the waterway where both banks have a gradual incline. Cross at a point known to be safe.
- Proceed at a slow steady speed to avoid submerged obstacles and slippery rocks.
- Avoid water crossings where the operation of a utility vehicle may cause damage to waterway beds or erode waterway shoreline.
- Stopping ability of vehicles with external brakes may be affected after driving through water. If necessary, apply brakes several times to dry them out.
- If water levels exceed the floorboard height at any time, contact your dealer to have the engine, transmission, differential fluids, and fuel tank checked for contamination.
- If the engine stops during water crossing, do not restart the engine. Major engine damage can result if the machine is not thoroughly inspected. Take the vehicle to your dealer before starting the engine.
- If you must continue to operate the vehicle prior to dealer inspection, perform the following inspection and service:
 - a. Move the vehicle to dry land, or at the very least to water below the floorboard.
 - b. Dry any water present in the air intake. Clean the air filter. Filter replacement is required if water is present.
 - c. Remove the spark plugs, keeping plug wires away from the spark plug mounting hole to avoid igniting fuel that may be in the cylinder. Turn the engine over several times using the electric start.
 - d. Dry the spark plugs and reinstall, or replace with new plugs.
 - e. Attempt to start the engine. If necessary, repeat the drying procedure. If engine does not start after three attempts, discontinue trying.
 - f. After driving through water when the air temperature is below freezing, clear the brake system of excess water, snow, mud or other material to prevent freezing.
 - g. If water has been ingested into the clutch enclosure, remove the drain plug to allow water to drain, then reinstall the plug. Run the engine for one minute to dry the drive belt. In Neutral, run engine up to full speed and back down several times to help dry the clutch sheave faces.
 - h. Take the vehicle to your dealer for service as soon as possible, whether you succeed in starting the engine or not. It is critical that services are performed to the engine, transmission, differential fluids, and fuel tank to check for contamination.

RH75544.000016B-19-02MAY13

Checking Wheel Hardware

- A serious accident could occur causing serious injury if wheel hardware is not tight.
- Check wheel hardware tightness often during the first 100 hours of operation.
- Wheel hardware must be tightened to specified torque using the proper procedure anytime it is loosened.

RH75544.000016C-19-08APR13

Wear Appropriate Clothing



MXAL41935—UN—18FEB13

- Always wear an approved helmet when operating the vehicle in an aggressive manner, on rough or uneven terrain, or at higher speeds.
- Helmets should fit properly and be approved for motorcycle use on standard roadways by the appropriate governing organizations for the region in which the vehicle is being used.
- Wear close fitting clothing and safety equipment appropriate for the job.
- Certain operating conditions may dictate that the operator and any passenger wear appropriate safety equipment while operating the vehicle. Be prepared for any existing and potential conditions before operating machine.
- Local safety or insurance regulations may require additional safety equipment, such as eye protection or a hard hat.
- Always wear substantial footwear and long trousers. Do not operate the equipment when barefoot or wearing open sandals.

MX00654.00000BD-19-05JUL17

Practice Safe Maintenance



MXAL41933—UN—18FEB13

- Only qualified, trained adults should service this machine.
- Understand service procedure before doing work. Keep area clean and dry.
- Never lubricate, service, or adjust machine while it is

Safety

moving. Keep safety devices in place and in working condition.

- Keep hands, feet, clothing, jewelry, and long hair away from any moving parts, to prevent them from getting caught.
- Disconnect battery(ies) or remove spark plug wires (for gasoline engines) before making any repairs.
- Keep all nuts and bolts tightened.
- Securely support any machine elements that must be raised for service work. Lock service latches before working on machine with raised attachments.
- Never run engine unless park brake is locked.
- Keep all parts in good condition and properly installed. Fix damage immediately. Replace worn or broken parts. Replace all worn or damaged safety and instruction decals.
- To prevent fires, remove any buildup of grease, oil, or debris from the machine, especially the engine.
- Do not modify machine or safety devices. Unauthorized modifications may impair its function and safety.
- Do not wear radio or music headphones while servicing the machine. Safe service requires your full attention.
- Disconnect battery ground cable(s) (-) on the machine or remove attachment from machine before welding on the machine.

RH75544,000016E-19-08APR13

Prevent Fires

- Please review these recommendations with all operators. See your John Deere dealer with questions.
- Always follow all safety procedures posted on the machine and in this operator's manual. Before carrying out any inspection or cleaning, always shut off engine, set parking brake, and remove ignition key.
- Besides routine maintenance, one of the best ways to keep your John Deere equipment running efficiently and to reduce fire risk is to regularly remove debris buildup from the machine.
- After operating, allow machine to cool in an open area before cleaning or storing. Do not park machine near flammable materials, such as wood, cloth, or chemicals, or near an open flame or other sources of ignition, such as a water heater or furnace.
- Completely remove any combustible materials from equipment before storing by emptying any grass catcher bags, containers, and cargo boxes.
- Debris can accumulate anywhere on the machine, especially on horizontal surfaces. Remove grass and debris completely from engine compartment, muffler area, and from the mower deck or cutting units both before and after operating machine. Additional

cleaning may be necessary when mowing or mulching in dry conditions.

- In addition to cleaning machine before using and storing, keeping engine area clean provides the greatest impact on fire prevention. Other areas requiring regular inspection and cleaning include behind wheel rims, wire harness, hose or line routing, mowing attachments, etc. Compressed air, leaf blowers, or high pressured water assists in keeping these areas clean.
- Frequency of these inspections and cleaning will vary depending on a number of factors, including operating conditions, machine configuration, operating speeds, and weather conditions, (particularly dry, hot, and windy conditions). When you are operating in these conditions, inspect and clean these areas frequently throughout the day.
- Excess lubrication or fuel/oil leaks or spills on the machine can also serve as collection sites for debris. Prompt machine repair and oil and fuel clean-up reduces the potential for debris collection.
- Bearing failures or overheating can result in a fire. To reduce this risk, always follow the instructions in the machine operator's manual regarding lubrication intervals and locations. Contact your local dealer if you have any questions about the lubrication intervals or location and if any unusual noises are coming from areas where bearings might be located. Washing the machine while warm may also reduce bearing life and increase potential for premature bearing failure.
- Always shut off fuel when storing or transporting machine, if the machine has a fuel shutoff.
- Check fuel lines, tank, cap, and fittings frequently for cracks or leaks. Replace if necessary.

OUO2005,0000221-19-05JUL17

Do Not Modify Machine

Do not make any unauthorized modifications to the machine in any way.

Modifications can result in making the machine unstable, increasing the possibility of rollover causing severe bodily injury or death.

RH75544,0000170-19-08APR13

Tire Safety



TCAL25965—UN—24MAY12

Explosive separation of a tire and rim parts can cause serious injury or death:

Safety

- Do not attempt to mount a tire without the proper equipment and experience to perform the job.
- Always maintain the correct tire pressure. Do not inflate the tires above the recommended pressure. Never weld or heat a wheel and tire assembly. The heat can cause an increase in air pressure resulting in a tire explosion. Welding can structurally weaken or deform the wheel.
- When inflating tires, use a clip-on chuck and extension hose long enough to allow you to stand to one side and NOT in front of or over the tire assembly.
- Check tires for low pressure, cuts, bubbles, damaged rims or missing lug bolts and nuts.

OUO2005.0000222-19-10MAY17

Handling Fuel Safely



MXAL41938—UN—18FEB13

To avoid personal injury or property damage, use extreme care in handling fuel. Fuel is extremely flammable and fuel vapors are explosive:

- Extinguish all cigarettes, cigars, pipes, and other sources of ignition.
- Use only an approved fuel container. Use only non-metal, portable fuel containers approved by the Underwriter's Laboratory (U.L.) or the American Society for Testing & Materials (ASTM). If using a funnel, make sure it is plastic and has no screen or filter.
- Never remove the fuel tank cap or add fuel with the engine running. Allow engine to cool before refueling.
- Never add fuel to or drain fuel from the machine indoors. Move machine outdoors and provide adequate ventilation.
- Clean up spilled fuel immediately. If fuel is spilled on clothing, change clothing immediately. If fuel is spilled near machine, do not attempt to start the engine but move the machine away from the area of spillage. Avoid creating any source of ignition until fuel vapors have dissipated.
- Never store the machine or fuel container where there is an open flame, spark, or pilot light such as on a water heater or other appliance.

- Prevent fire and explosion caused by static electric discharge. Static electric discharge can ignite fuel vapors in an ungrounded fuel container.
- Never fill containers inside a vehicle or on a truck or trailer bed with a plastic liner. Always place containers on the ground away from your vehicle before fueling.
- Remove fuel-powered equipment from the truck or trailer and refuel it on the ground. If this is not possible, then refuel such equipment with a portable container, rather than from a fuel dispenser nozzle.
- Keep the nozzle in contact with the rim of the fuel tank or container opening at all times until the fueling is complete. Do not use a nozzle lock-open device.
- Never overfill fuel tank. Replace fuel tank cap and tighten securely.
- Replace all fuel container caps securely after use.
- For gasoline engines, do not use gas with methanol. Methanol is harmful to your health and to the environment.

RH75544.0000172-19-16APR13

Handling Waste Product and Chemicals

Waste products, such as, used oil, fuel, coolant, brake fluid, and batteries, can harm the environment and people:

- Do not use beverage containers for waste fluids - someone may drink from them.
- See your local Recycling Center or authorized dealer to learn how to recycle or get rid of waste products.
- A Material Safety Data Sheet (MSDS) provides specific details on chemical products: physical and health hazards, safety procedures, and emergency response techniques. The seller of the chemical products used with your machine is responsible for providing the MSDS for that product.

RH75544.0000173-19-08APR13

Use Electronic Display Properly

Electronic displays are secondary devices intended to aid the operator in performing field operations, increase comfort and provide entertainment. Displays offer a wide range of functionality, are used in many different machine system applications and can be used with other secondary devices such as handheld electronic devices.

A secondary device is any device that is not required to operate your machine for its primary use. The operator is always responsible for safe operation and control of the machine.

To prevent injury while operating the machine:

- Position the display according to the installation instructions. Ensure that the device is secured and

Safety

does not obstruct the driver's view or interfere with the machine operating controls.

- Do not become distracted by the display. Stay alert. Pay attention to the machine and surrounding environment.
- Do not change settings or access any functions that require prolonged use of the display controls while machine is moving. Stop the machine in a safe location and place in park position before attempting such operations.
- Never set the volume so high that you cannot hear outside traffic and emergency vehicles.

To promote safe operation, certain functions of displays may be disabled unless the machine movement is restricted and/or has been placed in the park position. Overriding this safety feature may violate applicable law and can result in damage, serious injury, or death.

Only use available display functionality when conditions permit you to do so safely and in accordance with instructions provided. Always observe safe driving rules, state, or local laws and traffic regulations when using any secondary device.

DX,ELEC,DISPLAY-19-13JAN15

Machine Cleanout

General Cleaning Guidelines

Machine must be inspected periodically throughout the day. Buildup of debris must be removed to ensure proper machine function and to reduce the risk of fire. Frequency of these inspections and cleanings will vary depending on a number of factors including operating conditions, machine configuration, operating speeds, and weather conditions. Inspections and cleanings may be required multiple times throughout the day particularly in dry, hot, and windy conditions.

IMPORTANT: Regular and thorough cleaning of machine combined with other routine maintenance procedures listed in the Operator's Manual greatly reduce the risk of fire, downtime and improve machine performance.

Besides proper maintenance the condition of the material being handled is the most significant factor contributing to fires. Dry, light and fluffy materials that can create a dust cloud are the most likely to catch fire. Debris can accumulate in various areas especially on horizontal surfaces. Conditions such as wind speed and direction can change where the material accumulates. Be aware of these changing conditions and adjust your cleaning schedule and practices to ensure proper machine function and to reduce the risk of fire.

Always follow all safety procedures posted on the machine and in the Operator's Manual. Before carrying out any inspection or cleaning, always shut OFF engine, set parking brake and remove key.

The entire machine should be inspected, with extra attention given to the areas noted below.

OUMX068,0001043-19-10MAY17

Cleanout Areas

Primary areas that must be inspected and cleaned on the machine include (See Safety Label Section):

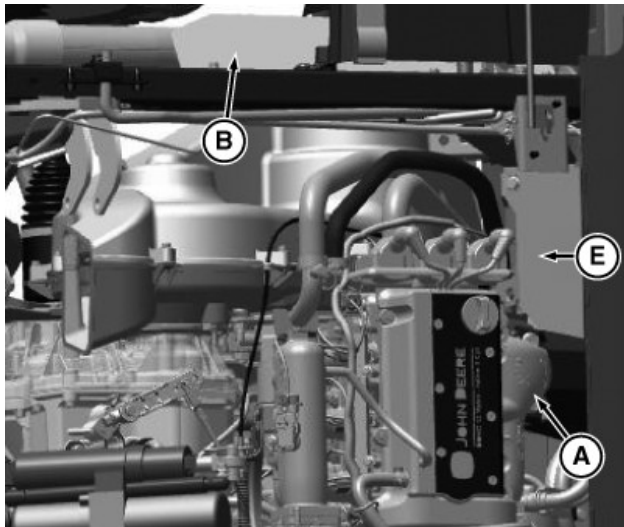

MXT023340—UN—02AUG18

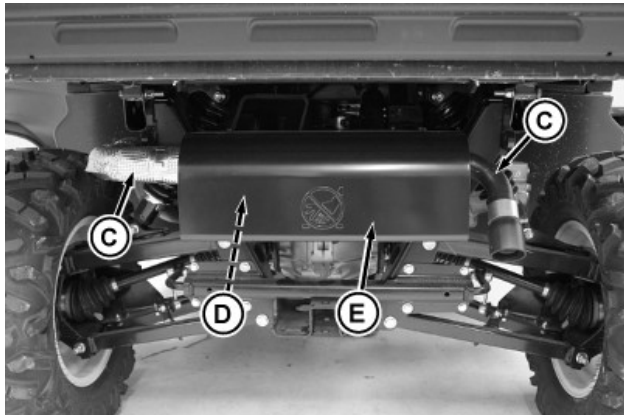

MXT018934—UN—23NOV16

1. Exhaust manifold (A) and shields (B), muffer pipes (C), muffer (D), and muffer shield (E).

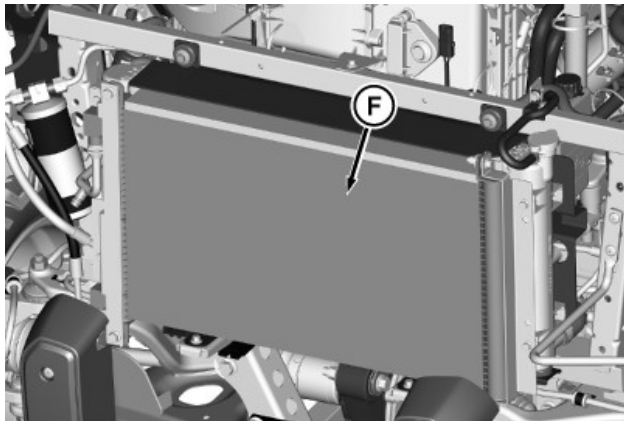

MXT018948—UN—28AUG17

Models with HVAC. Components hidden for better view.

2. Air-conditioning condenser fins (F).

Machine Cleanout

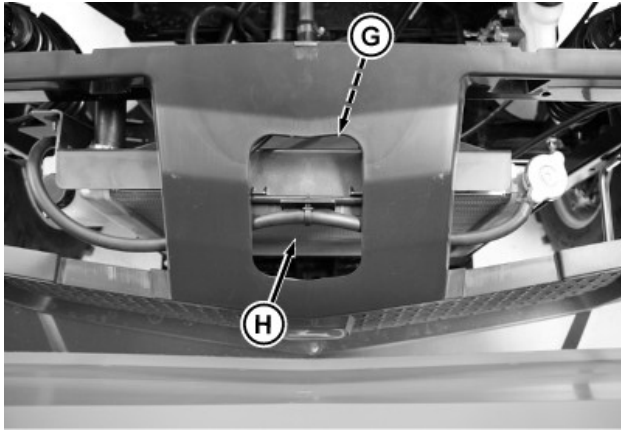

MXT018935—UN—28NOV16

3. Fan shroud (G) and radiator cooling fins (H).

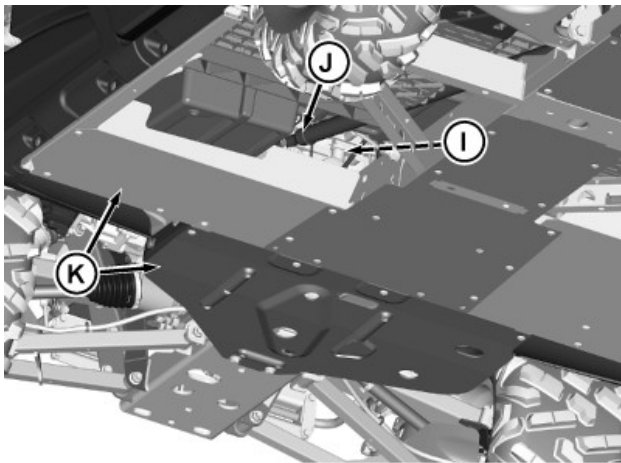

MXT018936—UN—28NOV16

4. Between engine (I), wire harnesses around bottom of battery, driveline (J), and skid plates (K).

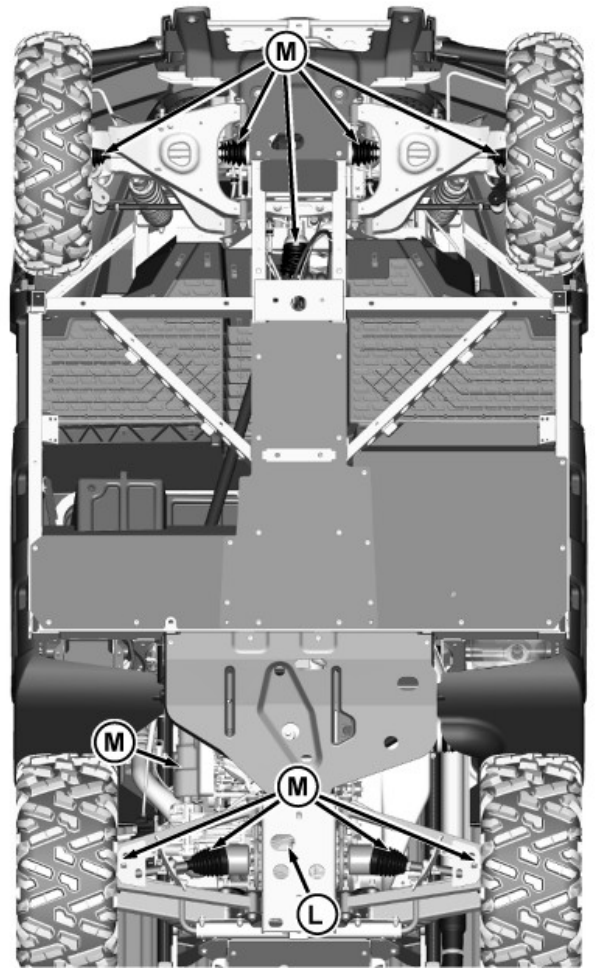

MXT018937—UN—28NOV16

5. On or near transmission (L) and driveline (M).

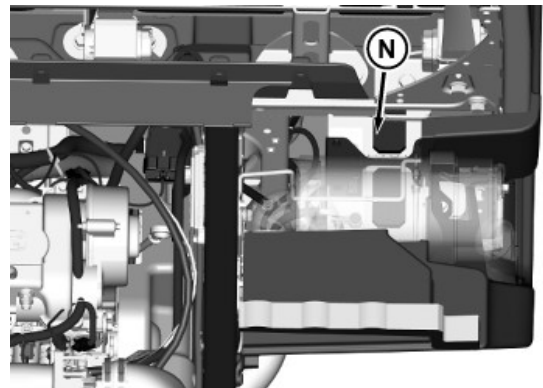

MXT018938—UN—28NOV16

6. Battery (N) and related wiring harnesses.

SB31882.000027A-19-31JUL18

Operating Controls

Operator Station Controls

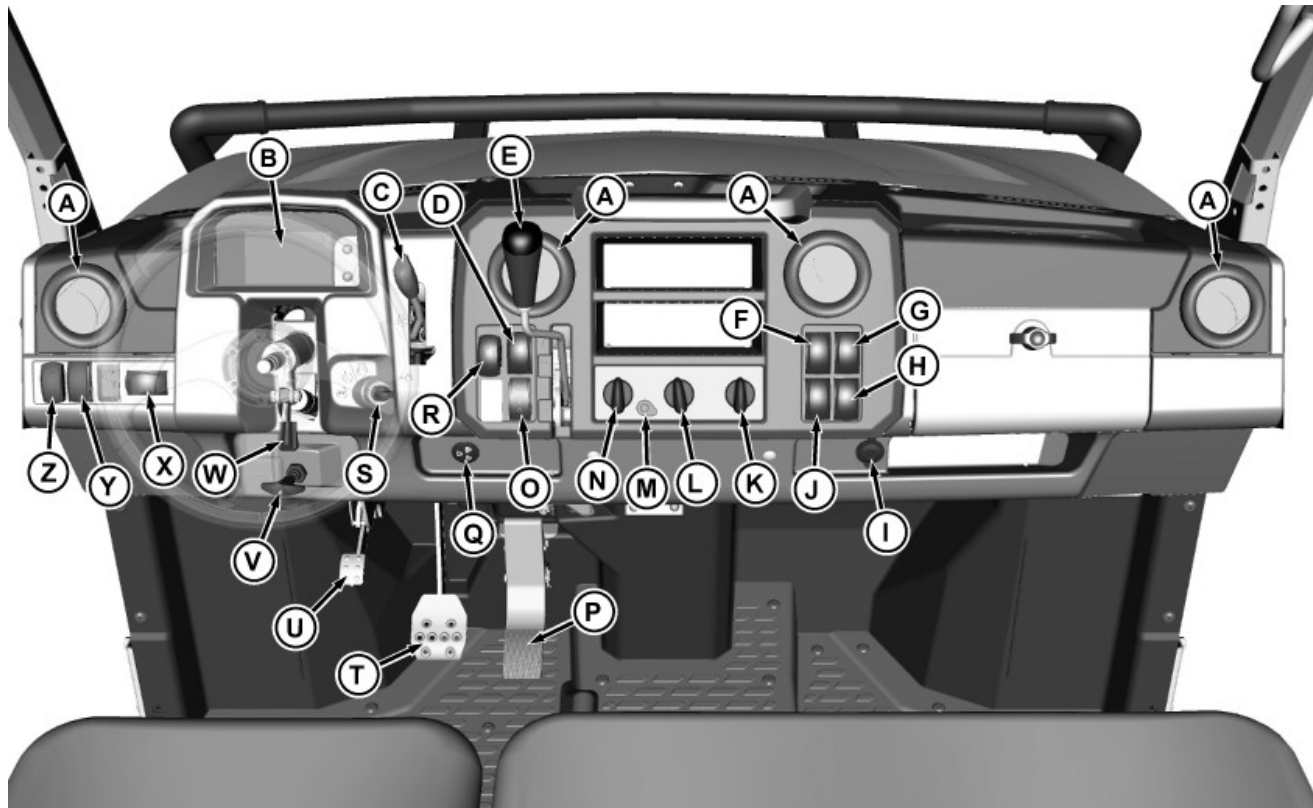

MXT018949—UN—29NOV16

Some controls may not be installed on your machine.

Key	Description	Key	Description
A	Air Vent	N	Blower Speed Control Knob
B	Instrument Cluster Controller	O	Windshield Washer Switch
C	Traction Assist (Differential Lock) Lever	P	Accelerator Pedal
D	Beacon Light Switch	Q	Park Brake Alarm
E	Transaxle Shift Lever	R	2WD/4WD Switch
F	Accessory Lights Switch	S	Ignition Key Switch
G	Accessory Lights Switch	T	Brake Pedal
H	Accessory Lights Switch	U	Park Brake Pedal
I	12 V DC Accessory Outlet	V	Park Brake Pedal Release
J	Hazard Lights Switch	W	Tilt Steering Lever
K	Ventilation Selector Knob	X	Turn Signal Switch
L	Temperature Control Knob	Y	Headlight Switch
M	Air-Conditioning Switch	Z	Cargo Box Power Lift Switch

OUMX068,00011E1-19-29AUG17

Operating

Daily Operating Checklist

- Test safety systems.
- Check tire pressure.
- Check fuel level.
- Check engine oil level.
- Remove grass and debris from engine compartment, muffler area, and front grille, before and after operating machine.
- Check area below machine for leaks.
- Check brakes and park brake operation.
- Inspect driveline CV boots for tears or punctures.
- Check coolant level.
- Check brake fluid level.
- Check air restriction indicator.
- Tighten any loose hardware.
- Check seat belt function.

MP47322,00F4837-19-03APR13

Avoid Damage to Plastic and Painted Surfaces

- Do not wipe plastic parts unless rinsed first.
- Insect repellent spray may damage plastic and painted surfaces. Do not spray insect repellent near machine.
- Be careful not to spill brake fluid on machine components. Brake fluid may damage painted surfaces. Wipe up spilled brake fluid immediately.
- Be careful not to spill fuel on machine. Fuel may damage surface. Wipe up spilled fuel immediately.

MX00654,00000C0-19-24AUG13

Load Shedding

While operating equipment or attachments on some machine models, power may be reduced or cut off to avoid damage to the battery. On HVAC equipped machines, the blue AC light blinks during a load shed condition. Other more severe load shedding conditions are indicated with a solid battery indicator on the display. See your John Deere dealer for additional information.

OUMX068,00011E3-19-01AUG18

Using Doors or Nets

⚠ CAUTION: Avoid injury! Do not operate vehicle with doors or nets removed. Always park vehicle safely before opening door or net to exit.

Do not operate vehicle with doors or nets in the open position. All doors or nets must be closed while the vehicle is in use.

Using Doors

Entering vehicle:



MXT018950—UN—30NOV16

1. To unlatch and open the door, grasp the handle and push in the lock button (A).
2. After entering the vehicle, check to be certain the door is securely latched.

Exiting vehicle:

1. Park vehicle safely.



MXT018951—UN—30NOV16

2. To unlatch and open the door, pull handle (B) toward you.
3. After exiting the vehicle, check to be certain the door is securely latched.

Using Nets

Entering vehicle:

1. Move net rearward out of entry and exit area, and enter vehicle.

Operating



MXT018952—UN—30NOV16

2. Move net forward and insert the metal tab of the net into buckle (A) until it latches.
3. After entering the vehicle, check to be certain the net is securely latched.

Exiting vehicle:

1. Park vehicle safely.
2. Push button to release the metal tab from buckle (A).
3. Move net rearward out of entry and exit area, and exit vehicle.

OUMX068,00011E2-19-08SEP17

Using Hand Holds

Hand holds are provided for passenger balance.

Machines With Doors

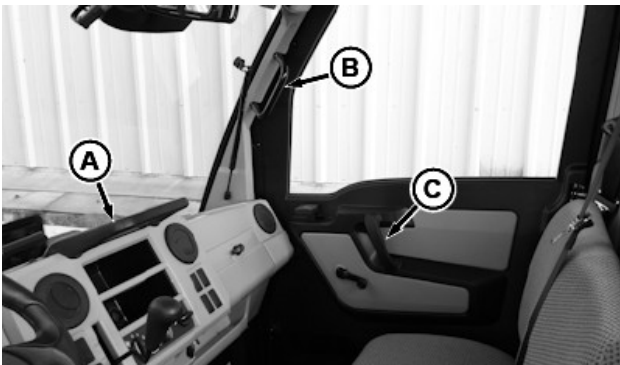

MXT008515—UN—01SEP17

- When a passenger is in the center, they must use the dash bar (A) hand hold at all times while the machine is moving.
- When a passenger is on the right, they must use two of the three hand holds at all times while the machine is moving: the dash bar (A), protective structure handle (B), and hand hold on door (C).

Machines With Nets

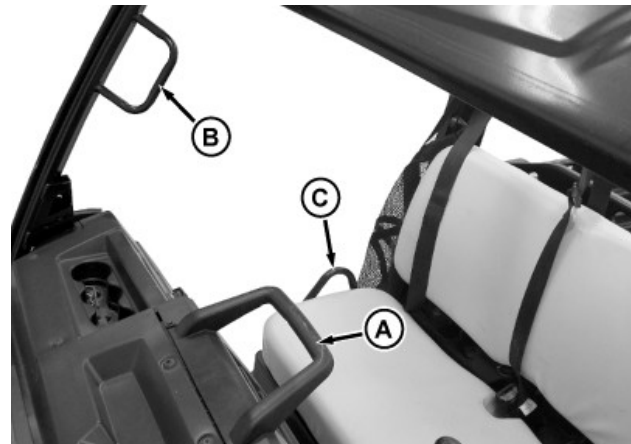

MXT020774—UN—25AUG17

- When a passenger is in the center, they must use the dash bar (A) hand hold at all times while the machine is moving.
- When a passenger is on the right, they must use two of the three hand holds at all times while the machine is moving: the dash bar (A), protective structure handle (B), and side rail (C).

MX10673,0000083-19-09SEP17

Using Bench Seat

Bench (passenger) seat is not adjustable.

See SERVICE MISCELLANEOUS for instructions to install and remove bench seat.

MX10673,000005E-19-01SEP17

Adjusting Operator Seat

⚠ CAUTION: Avoid injury! Never adjust seat while machine is moving. Stop machine before adjusting seat to prevent loss of machine control.

1. Stop machine and move transaxle shift lever to N (neutral) position.
2. Lock park brake.

Operating

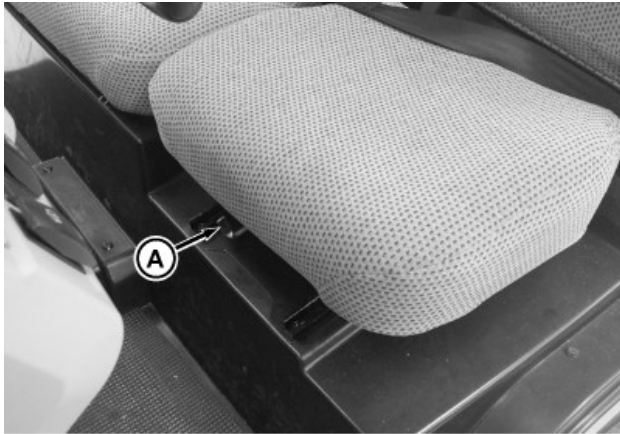

MXT018955—UN—28AUG17

3. Push lever (A) to the left.
4. Slide seat forward or rearward to desired position.
5. Release lever.

OUMX068,00011E5-19-08SEP17

Using Seat Belt

NOTE: Shoulder harness is sensitive. An emergency lock device is built into the belt for your protection. To engage harness, pull harness slowly. Attempting to pull too fast or in a jerking motion engages the locking mechanism and the harness does not release.

Periodically inspect seat belts for wear or damage. See Inspecting Seat Belt in Service Miscellaneous section.

Fasten Belt



MXT018956—UN—01DEC16

1. Grasp outer seat belt connector (A) from behind seat, pull out and across body to inner connector (B) at inside of seat.
2. Adjust outer connector up or down along the belt for the best fit.
3. Push outer connector lower half (C) firmly into inner connector until it locks.
4. Snug the seat belt across the hips, on top of the thighs.

Release Belt

1. To release seat belt, press red button on inner connector.

Adjust Belt

The shoulder harness can be raised for the comfort of taller operators.

Operating

Testing Safety Systems

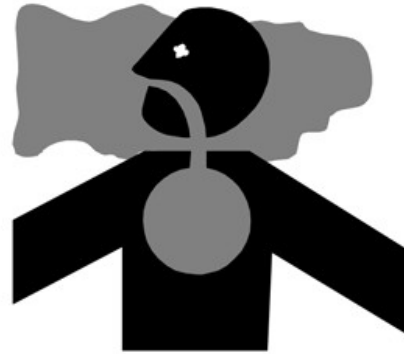

MXAL42804—UN—09APR13

CAUTION: Avoid injury! Engine exhaust fumes contain carbon monoxide and can cause serious illness or death.

Do not run an engine in an enclosed area, such as a garage, even with doors or windows opened.

Move the machine to an outside area before running the engine.

The safety systems installed on your machine should be checked before each machine use. Be sure you have read the machine operator manual and are completely familiar with the operation of the machine before performing these safety system checks.

Use the following checkout procedures to check for normal operation of machine.

If there is a malfunction during one of these procedures, do not operate machine. **See your authorized dealer for service.**

Perform these tests in a clear open area. Keep bystanders away.

MP47322,00F4637-19-26MAY15

Testing the Safety Start System

NOTE: The engine can start with the transaxle in gear. The machine has a brake pedal safety start switch. The brake pedal must be pushed down to start the engine.

1. Sit on the operator's seat.
2. Put ignition key switch in STOP position.
3. Lock park brake.
4. Move transaxle shift lever forward to N (Neutral) position.
5. Turn ignition key switch to START position. Engine should not crank. Turn ignition key switch to STOP position.



MXT023341—UN—01AUG18

Cab Option Shown

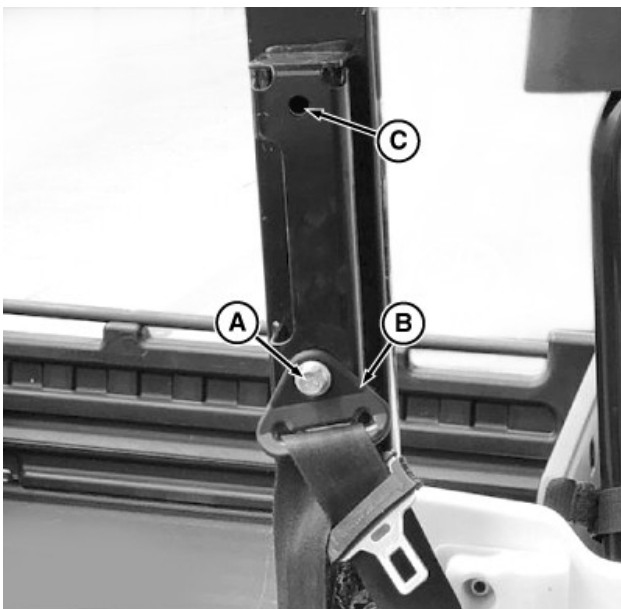

MXT023342—UN—01AUG18

No Cab Option Shown

A—Bolt, Flanged Head
B—Bracket, Shoulder Harness
C—Mounting Hole, Upper

1. To raise the shoulder harness, remove bolt (A) and bracket (B).
2. Position bracket (B) over the upper mounting hole (C).
3. Secure bracket (B) with bolt (A). Tighten bolt to 70.5 N·m ± 13.5 N·m (52 lb·ft ± 10 lb·ft).

OUMX068,00011E6-19-30AUG18

Operating

6. Push down on brake pedal.
7. Turn ignition key switch to START position. Engine should crank, allowing engine to start.
8. Allow engine to run a few seconds.
9. Turn ignition key switch to STOP position.

MX10673,0000028-19-30AUG18

Adjusting Tilt Steering Wheel

CAUTION: Avoid Injury! Do not attempt to adjust the steering wheel while the machine is moving. The operator can lose control of the machine.

- Stop the machine before adjusting the steering wheel.
- Lock the steering wheel in position before driving the machine.

1. Stop machine.



MXT018979—UN—03JAN17

2. To release the steering wheel, press down on lever (A).
3. Adjust steering wheel to desired position and release lever.

OUMX068,00011FD-19-03JAN17

Using Park Brake

NOTE: The park brake alarm buzzes if the machine is in gear and you try to move in forward or reverse before unlocking the park brake. The alarm also buzzes on some machines if you exit the machine without engaging the park brake.

CAUTION: Avoid injury! Children or bystanders can attempt to move or operate an unattended machine.

Always lock the park brake and remove the key before leaving the machine unattended.

IMPORTANT: Avoid damage! Damage to brake occurs when machine travels with brake locked.

Unlock park brake before beginning machine travel.

Locking the Park Brake:

1. Push down firmly on the park brake pedal in one motion until several clicks are heard.
2. Be sure that machine is motionless before getting off the seat.

Unlocking the Park Brake:

1. To avoid debris getting on driver, place foot on park brake lever when releasing the park brake.
2. Pull out release handle on dash under the steering wheel. Allow brake pedal to return to the unlocked position.

OUMX068,00011DE-19-30AUG18

Using Travel Controls

1. Stop machine.
2. Allow engine to come to a low idle speed.

IMPORTANT: Avoid damage! Do not shift gears when vehicle is moving or with engine running higher than low idle speed. Push down brake to stop vehicle motion and engage shift lever with a firm positive action.

Gears may grind when shifting if engine idle speed is set higher than factory specification.

NOTE: Always shift into low range when operating on wet or uneven terrain, or when towing or pushing heavy loads.

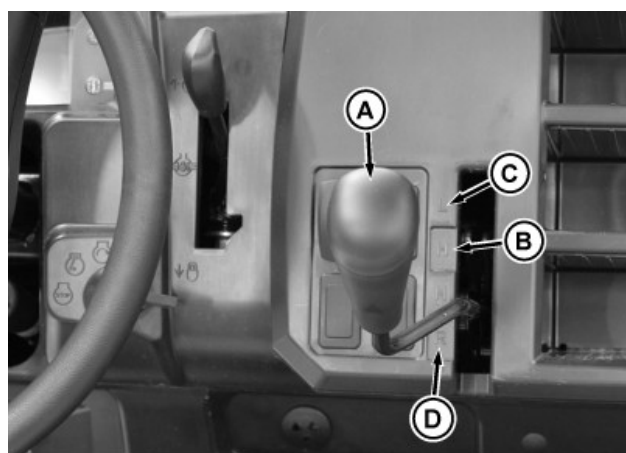

MXT018957—UN—01DEC16

3. Select a gear position:
 - Forward - Push shift lever (A) up to either high (B) or low (C) range.

Operating

- Reverse - Pull shift lever down to reverse (D) gear.
4. Look in the direction of machine travel.
- CAUTION: Avoid injury! Reduce speed before braking or turning, when hauling loads, and while operating around obstacles or on hazardous off-road conditions.**
5. Push down on accelerator pedal slowly and smoothly to begin machine travel.
 6. Release accelerator pedal and apply the brake pedal evenly and firmly to slow down or stop.

OUMX068,00011E7-19-01DEC16

Using Headlights

Ignition key switch must be in the RUN position to operate the lights. If the ignition key switch is in the RUN position and the engine is not running, the battery will discharge if the lights are allowed to remain on for an extended period of time.

- Press top of light switch to turn headlights on.

NOTE: Be sure to turn lights off and turn the ignition key switch to STOP position, or lights will discharge battery.

- Press bottom of light switch to turn headlights off.

MP47322,00F4842-19-03APR13

Using Ignition Key Switch

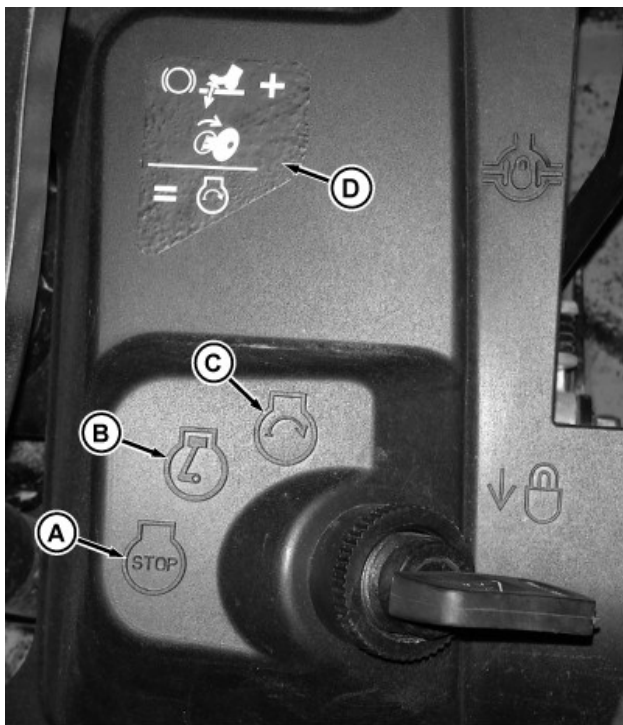

MXT020776—UN—28AUG17

- A - STOP Position** - With key in STOP position, all switched power is off, and engine should not run.
- B - RUN Position** - Turn key from STOP to this position and all switched power circuits are on.
- C - START Position** - Turn key to START position to start the engine. Release key after engine has started and it automatically returns to the RUN position. The engine continues to run.
- D - Depress the brake pedal and turn the key to the START position to start the engine.**

MX10673,0000032-19-30AUG18

Using Instrument Cluster Controller

NOTE: Depending on the machine model, some functions are not available.

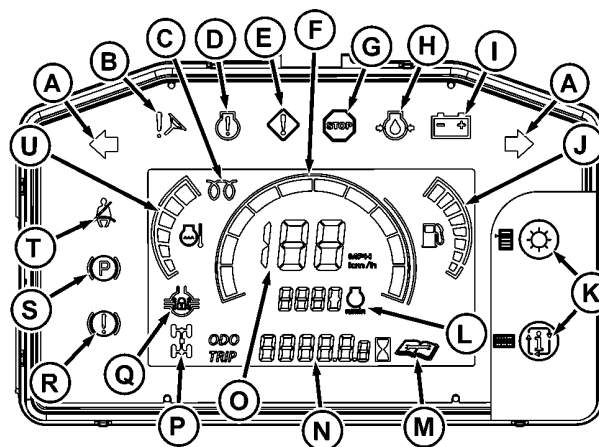

MXT020153—UN—17MAY17

Some indicators may not be displayed on your machine.

NOTE: "Troubleshooting Required" indicates that additional diagnosis is required to isolate the problem. See your Authorized John Deere Dealer for service.

- A - Turn Signal Indicator** - The left or right signal indicator flashes when turn signal is active.
- B - Electric Power Assist Steering (EPAS) Malfunction Indicator** - This indicator illuminates or flashes when the EPAS system detects a fault. The level of assist may also be decreased. Troubleshooting is required.
- C - Glow Plug Indicator** - The indicator illuminates while the glow plugs are heating after the ignition key switch is placed in the RUN position. Depending on the temperature, the indicator turns off in approximately 0-10 seconds indicating that the engine can be started.

Operating

D - Engine Malfunction Indicator - This indicator illuminates or flashes when an engine fault has been detected. Troubleshooting is required.

E - Operator Alert Indicator - This indicator illuminates when a fault has been detected that does not require the machine to be stopped immediately. Troubleshooting is required.

F - Speedometer/Engine RPM Gauge - The bar gauge can be set to show engine or wheel speed.

G - Stop Indicator - This indicator illuminates or flashes alerting the operator to a condition that requires immediate attention and to stop the machine. Troubleshooting is required.

H - Low Engine Oil Pressure Indicator - This indicator illuminates or flashes when the engine is running and the engine oil pressure is too low. Troubleshooting is required.

I - Battery Indicator - This indicator illuminates or flashes when a low or high voltage has been detected. Turn off electrical loads.

J - Gas Gauge - The bar graph has eight segments representing actual fuel level. Each bar displays approximately 1/8 of a full fuel tank. If there is less than 1/8 of a tank (no bars illuminated) the gas symbol blinks.

K - Instrument Cluster Controller Buttons - These buttons are used to activate certain instrument cluster controller functions. For detailed instructions, see Using Instrument Cluster Controller Buttons in OPERATING Section.

L - RPM Gauge - This gauge shows a digital readout of the current engine RPM value.

M - System Diagnostic Indicator - This indicator illuminates or flashes for system malfunctions that do not have a specific indicator. Troubleshooting is required.

N - Odometer, Trip Meter, Hour Meter Gauge - This indicator shows the accumulated kilometers/miles the machine has traveled, along with a trip meter. The hour meter portion shows the accumulated number of operating hours the engine has run. The hour meter displays operating hours and accumulates and displays operating hours when the engine is running. The hour meter is intended to provide a means of monitoring machine usage for maintenance purposes. Use the hour meter to determine when your machine has reached the recommended service intervals.

O - Speedometer - The speedometer indicates machine speed in km/h or mph.

P - 4WD Indicator - This indicator illuminates when four-wheel drive is enabled.

Q - Differential Lock Indicator - This indicator illuminates when the differential lock is engaged.

R - Brake System Alert Indicator - This indicator

illuminates when the brake fluid falls below the acceptable level. Troubleshooting is required.

S - Park Brake Indicator - This indicator illuminates when the park brake is partially or fully engaged.

T - Seat Belt Indicator - This indicator illuminates or flashes when the driver seat belt is not secured.

U - Coolant Temperature Gauge - This gauge displays the current engine temperature. If the temperature rises to an overheat condition, the stop indicator (G) illuminates.

Equipment for Non-Road Homologated Machines

X - Denotes which indicators in the instrument cluster are active based on the machine model.

O - Denotes which indicators in the instrument cluster are optional based on the machine model.

Indicators	XUV835	XUV865
Turn Signal	O	O
Electric Power Assist Steering	O	O
Glow Plug (Diesel only)		X
Engine Malfunction	X	
4WD	X	X
Differential Lock		
Brake System Alert		
Low Engine Oil Pressure	X	X
Gas Gauge	X	X
RPM Gauge	X	X
Coolant Temperature Gauge	X	X

Equipment for Road Homologated Machines

X - Denotes which indicators in the instrument cluster are active based on the machine model.

O - Denotes which indicators in the instrument cluster are optional based on the machine model.

Indicators	XUV835	XUV865
Turn Signal	X	X
Electric Power Assist Steering	O	O
Glow Plug (Diesel only)		X
Engine Malfunction	X	
4WD	X	X
Differential Lock		
Brake System Alert	X	X
Low Engine Oil Pressure	X	X
Gas Gauge	X	X
RPM Gauge	X	X
Coolant Temperature Gauge	X	X

MX10673.000004F-19-30AUG18

Operating

Using Instrument Cluster Controller Buttons

1. Turn the ignition key switch to run position.

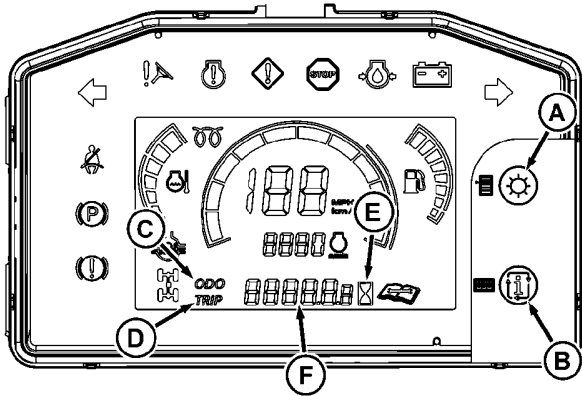

MXT019881—UN—17FEB17



MXT020182—UN—15JUN17

Display Brightness Screen

2. Adjust the display brightness by pressing the select button (A).

Odometer, Trip Meter, and Hour Meter

Toggle between odometer, trip meter, and hour meter Home screens by pressing the cycle button (B).



MXT020183—UN—15JUN17

- When "ODO" (C) is displayed, the odometer indicator (F) displays the number of miles or km the machine has moved. (To change between miles or km displayed, see System Settings Menu.)



MXT020184—UN—15JUN17

- When "TRIP" (D) is displayed, the indicator (F) displays the number of miles or km the machine has moved for a certain trip. (To change between miles or km displayed, see System Settings Menu.)



MXT020185—UN—15JUN17

- When the hour meter (E) is illuminated, the indicator (F) displays the number of operating hours the engine has run.

System Settings Menu

To enter the System Settings Menu from the Home screen, press and hold the select button (A) for the required time. Pressing the cycle button (B) toggles through the Tire Size, Display Units, Speed Units, and two Diagnostic Trouble Codes (DTC) menus.

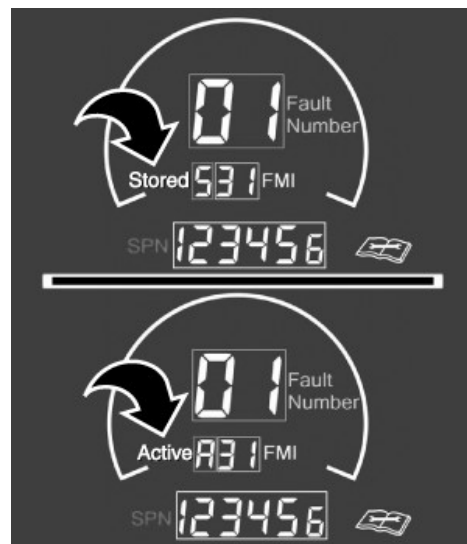

MXT023435—UN—31AUG18

Stored and Active Diagnostic Trouble Codes

Operating

(DTC menus are provided for diagnosing a machine malfunction. See your John Deere dealer for service.)

NOTE: If vehicle speed is greater than 4.8 km/h (3 mph), no menu settings are allowed.

NOTE: While in a main or sub menu item, if no button is pressed within the required time, the settings menu returns to the current Home screen. Press and hold the select button for the required time to get back to the settings menus.

Tire Size Selection Menu



MXT019883—UN—17FEB17

14 inch Tire Size Shown

This menu allows the operator to adjust for the tire sizes available. The current setting is displayed on the lower seven segment section when entering the option menu structure.

To enter the tire size menus, press the select button (A). To toggle through and display the tire sizes, press the cycle button (B). The tire size value displayed flashes every 1 second. When the desired tire size is displayed, press the select button. The tire size remains solid on for 1 second, and then the display returns to the Main Menu for this setting.

Display Units Selection Menu



MXT019884—UN—17FEB17

English Display Units Shown

This menu allows the operator to select either English or metric units when applicable. The current setting is displayed on the lower seven segment section when entering the option menu structure.

To enter the display units menus, press the select button (A). To toggle between US/mph and SI/km/h, press the cycle button (B). The display unit text and icon flashes every 1 second. When the desired display unit is

displayed, press the select button. The display unit text and icon remains solid on for 1 second, and then the display returns to the Main Menu for this setting.

Engine RPM/Speedometer Gauge Selection Menu



MXT019885—UN—17FEB17

Vehicle Speed Option Shown

This menu allows the operator to change the center bar graph to show a graphical representation of either the vehicle speed or engine rpm. On the Home screen, an icon identifies which option is selected. The current setting is displayed on the lower seven segment section when entering the option menu structure. "CYC" identifies the gauge as being in the engine tachometer mode. The "SP" identifies the gauge as being in the vehicle speedometer mode. Both modes show a graphical approximation of the selected mode.

To enter the engine rpm/speedometer menus, press the select button (A). To toggle between SP/mph and CYC/rpm, press the cycle button (B). The display unit text and icon flashes every 1 second. When the desired display unit is displayed, press the select button. The display unit text and icon remains solid on for 1 second, and then the display returns to the Main Menu for this setting.

OUMX068,000129D-19-31AUG18

Exit Lighting Operation



MXT019886—UN—17FEB17

Countdown Timer

Function

A method for a "soft" shutdown of lighting after the ignition key switch is turned off.

Operating

Operation

When the ignition key switch is turned off, certain circuits remain on. The bar gauge represents a countdown to power removal.

OUMX068,000123B-19-30AUG18

Using Accessory Outlet

Two outlets may be installed depending upon your machine model:

- 10 A outlet in the glove box (M-spec models equipped with HVAC and R models)
- 10 A outlet on the machine dashboard (All models)

CAUTION: Avoid injury! Safe operation requires your full attention. Do not wear radio or music headphones while operating machine.

NOTE: Accessory must be rated at given amps for outlet or less.

The accessory plug on E-spec vehicles turns ON when the key is turned ON, and OFF when the key is turned OFF. The accessory plugs on M-spec and R-spec vehicles turn ON when the key is turned ON, and will turn OFF at the end of the Exit Lighting Operation (10 seconds).

1. Remove 12 volt outlet cover and install accessory cord in the outlet.
2. Install cover in the outlet after use.

OUMX068,00011FB-19-01AUG18

Using Turn Signal Switch (If Equipped)

NOTE: Turn signals will continue to flash when the ignition key switch is in the STOP position, discharging the battery.

- Press at left end of turn signal switch to signal a left turn.
- Press at right end of turn signal switch to signal a right turn.
- Press at opposite end of turn signal switch until switch is centered to turn signal light off.

MP47322,00F4847-19-03APR13

Using Hazard Lights (If Equipped)

NOTE: Hazard lights will continue to flash when the ignition key switch is in the STOP position, discharging the battery.

- Press at top of hazard light switch to turn hazard lights on.
- Press at bottom of hazard light switch to turn hazard lights off.

MP47322,00F4848-19-03APR13

Using Front Blade Switch (If Equipped)

- Press at top of front blade switch to raise blade.
- Press at bottom of front blade switch to lower blade.

MP47322,00F4849-19-03APR13

Using HVAC Controls (If Equipped)

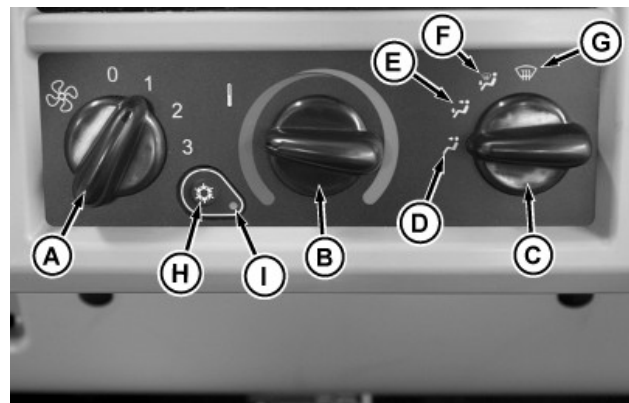

MXT018980—UN—04JAN17

1. To adjust blower speed, turn knob (A):
 - 0 = Off
 - 1 = Low
 - 2 = Medium
 - 3 = High
2. To adjust air temperature, turn knob (B):
 - a. Turn knob counterclockwise for cooler temperature.
 - b. Turn knob clockwise for warmer temperature.
3. To control the direction of the airflow, turn knob (C) to desired setting. There are four airflow selections (D—G):
 - D = Dash Vents
 - E = Dash and Floor Vents
 - F = Defroster Vents and Floor Vents
 - G = Defroster Vents
4. To turn on the air conditioning, press button (H). Indicator light (I) illuminates blue. To turn off the air conditioning, press button again.

OUMX068,00011FE-19-04JAN17

Operating

Using Storage Areas

Under Machine Hood

NOTE: An optional Storage Tub Kit is available for machines without HVAC. See your John Deere dealer.

CAUTION: Avoid injury! Never store flammable, heavy, or loose breakable objects in the storage tub. Always latch hood before operating machine.

IMPORTANT: Avoid damage! Do not store items that prevent the hood from closing properly. Properly secure loose or sharp items. These items can damage the storage tub or other items within the tub.

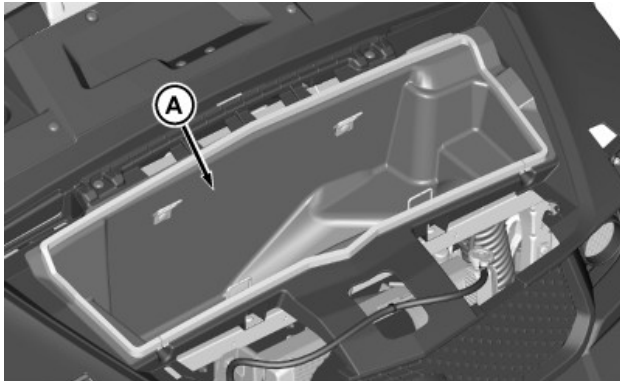

MXT018953—UN—01DEC16

1. Open hood to access the storage tub (A).
2. To prevent damage from movement while operating the machine, secure all items.
3. Close hood.

Under Bench Seat

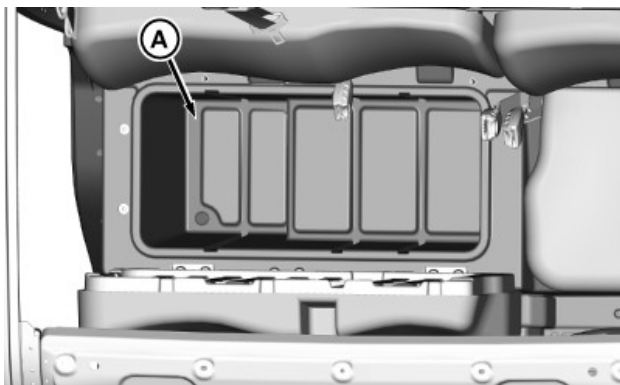

MXT018954—UN—01DEC16

1. Raise passenger seat to access the storage tray (A).
2. To prevent damage from movement while operating the machine, secure all items.
3. Lower seat.

OUMX068,00011E4-19-01DEC16

Starting the Engine

CAUTION: Engine exhaust fumes contain carbon monoxide and can cause serious illness or death.

- Move the machine to an outside area before running the engine.
- Do not run an engine in an enclosed area without adequate ventilation.
- Connect a pipe extension to the engine exhaust pipe to direct the exhaust fumes out of the area.
- Allow fresh outside air into the work area to clear the exhaust fumes out.

1. Sit on operator seat. Do not start engine at this time.
2. Push down on accelerator pedal to check free movement of pedal assembly. Release pedal.
3. Verify that transaxle shift lever is in N (Neutral) position.
4. Verify that park brake is locked.

NOTE: The engine can start with the transaxle in gear. The machine has a brake pedal safety start switch. The brake pedal must be pushed down to start the engine.

On some machine models, starter crank protection may engage and you will be unable to crank the engine for approximately ten seconds.

5. Push and hold the brake pedal down to engage the safety start switch.

CAUTION: Do not start engine by shorting across starter terminals. Bypassing normal circuitry will allow vehicle to start in gear.

Do not use starting fluid to aid engine starting.

Never start engine while standing on ground. Start engine only from operator's seat.

6. Turn ignition key switch to the RUN position.
7. Check that the following indicator lights turn on briefly:
 - Battery discharge light (machines without Electric Power Assist Steering).
 - Oil pressure light.
 - Glow plug/coolant temperature light for approximately 0-9 seconds, depending on temperature.
 - Electric Power Assist Steering (EPAS) and battery voltage indicator light.
8. When the glow plug/coolant temperature light turns off, turn ignition key switch to START position.

Operating

IMPORTANT: Starter may be damaged if operated continuously for extended periods of time. Allow starter to cool down after several starting attempts.

9. Release ignition key switch to the RUN position when engine starts.
 - If engine does not start within five seconds, turn ignition key switch to STOP position and wait ten seconds before trying to start again.
 - In very cold conditions, attempt starting engine three times only, then wait 5 minutes before trying again. This will allow time for starter to cool and prevent damage to starter.

IMPORTANT: Do not operate the engine at full throttle or under load until engine has warmed up, or engine damage could occur.

10. Run engine at half speed for 2 or 3 minutes to warm the engine.

MX10673,0000036-19-26JUL17

Stopping Engine

⚠ CAUTION: Children or bystanders may attempt to move or operate an unattended machine.

Always lock the park brake and remove the key before leaving the machine unattended.

IMPORTANT: Do not stop engine immediately after hard or extended operation. Keep engine running at low idle for about 2 minutes to prevent heat build-up.

1. Stop machine.
2. Move transaxle shift lever to N (Neutral) position.
3. Lock park brake.
4. Turn ignition key switch to STOP position.
5. Remove key.

MP47322,00F484C-19-03APR13

Emergency Stopping

1. Remove foot from travel pedal or accelerator pedal.
2. Depress brake pedal. Do not release brake pedal until machine has stopped.
3. After machine has stopped, lock the park brake.
4. Turn ignition key switch to STOP position.

MP47322,00F484D-19-03APR13

Using Electric Power Assist Steering (EPAS)

The Steering Malfunction Light will indicate if there is a malfunction in power assist steering.

The light may go off and on during operation as an indicator that EPAS has been reduced to protect the system. The fault indication may be cleared automatically when the fault condition is removed.

The level of assist decreases as the speed increases, with full assist with zero speed.

Normal steering operation has the EPAS indicator light off.

If the indicator light remains on constantly or flashes continually during operation, contact your John Deere dealer.

Steering effort is adversely affected by low tire air pressure. Always keep tires at recommended air pressure.

MX10673,0000086-19-09SEP17

Using Traction Assist

Traction assist provides better traction when rear wheels start to slip. Engaging the traction assist causes both rear wheels to turn together at equal speed.

⚠ CAUTION: Avoid injury! Driving at high speeds with the traction assist engaged may result in loss of steering control. Do not engage traction assist or turn with the traction assist engaged while operating machine at high speeds or on slopes.

Engaging the Traction Assist:

IMPORTANT: Avoid damage! Incorrectly engaging traction assist may damage the transaxle.

Reduce speed before engaging or disengaging traction assist.

1. Stop or reduce engine speed to 1/3 throttle or less.
2. Pull traction assist lever down to the locked position.
 - Traction assist remains engaged as long as the lever is in the locked position.

Disengaging the Traction Assist

NOTE: To ensure true disengagement of traction assist, torque on both axles must be equalized.

1. Stop or reduce engine speed to 1/3 throttle or less.
2. Drive the vehicle straight ahead at a constant speed.

Operating

3. Push traction assist lever up to the unlocked position.

OUMX068,00011FC-19-03JAN17

Using Four Wheel Drive

4WD On-Demand enables the front wheels to drive, but torque will not be applied until rear wheels begin to slip.

CAUTION: 4WD On-Demand greatly increases traction and may make dangerously sloped terrain accessible, increasing possibility of a tip-over.

Use extra caution when driving on slopes. Use 4WD On-Demand when driving on slopes to increase traction.

Use 4WD On-Demand when driving on icy, wet or graveled surfaces; reduce speed to avoid skidding and loss of steering control.

IMPORTANT: Engaging 4WD On-Demand when the machine is stopped and the rear wheels are spinning will damage the gears.

- Push in on top of 2WD/4WD switch to enable the 4WD On-Demand system.
- Push in on bottom of switch to disable the system.

CAUTION: Front implements may cause decreased traction at the rear wheels resulting in loss of control. Always operate machine with 4WD On-Demand engaged when front implements are attached.

Tips for operating 4WD On-Demand:

NOTE: Occasionally the 4WD On-Demand system will not disengage after a change in vehicle travel direction. This is known as "wedging." If this does occur, the vehicle will exhibit higher than usual steering efforts and driveline wind-up. To disengage (un-wedge) the system, reverse the direction of vehicle travel.

- Maintain recommended front and rear tire pressures to ensure optimum performance on all surface conditions.
- Disable 4WD On-Demand when driving machine on paved or hard packed surfaces to increase front tire life and reduce drive train wear.

MP47322,00F4850-19-03APR13

Using the Cargo Box

CAUTION: Avoid injury! Seating is provided for the operator and one or two front seat passengers when equipped with bench seat. When equipped with bucket seats, seating is provided for operator and one front seat passenger. Do not allow riders in the cargo box or on the tailgate. Extra riders can fall off and can be seriously injured or killed.

Raising and Lowering with Manual Lift

CAUTION: Avoid injury! Park machine on a level surface and lock park brake before manually raising and securing cargo box in raised position.

A cargo box containing material is heavy.

Empty some or all material until cargo box can safely be raised manually.

1. Park the vehicle safely. (See Parking Safely in the Safety section.)
2. Empty cargo box by hand.
3. Disengage cargo box lock if installed.

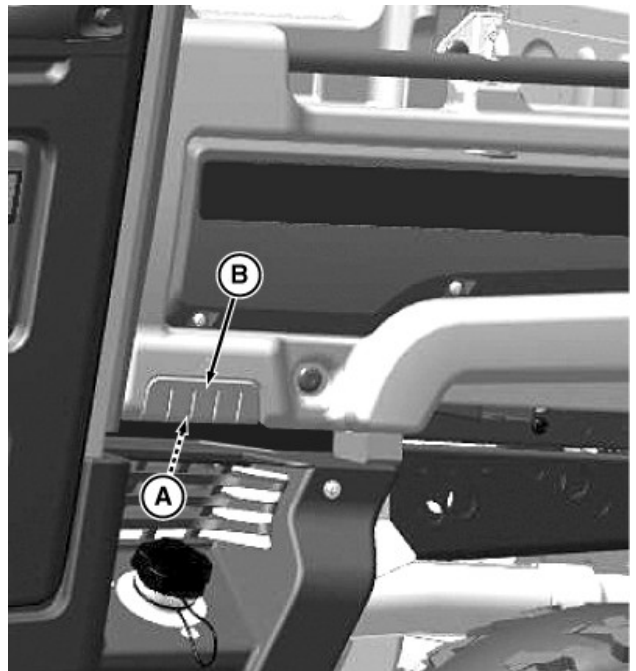

MXT023343—UN—01AUG18

4. To release pressure against latch (A), push down on cargo box.
5. Release latch by pulling latch towards grip (B) on cargo box. Allow lift cylinder to raise cargo box.

Operating

Raising and Lowering with Power Lift

IMPORTANT: Avoid damage! A hydraulic “whine” or squealing sound when cargo box is fully raised or lowered or when box is heavily loaded indicates that the power lift hydraulic overload pressure relief valve has opened, and the power lift can not apply any more force. To prevent unnecessary wear or damage, keep sound to a minimum. Do not operate the power lift actuator beyond full stroke or exceed the cargo box weight capacity.

1. Park the vehicle safely. (See Parking Safely in the SAFETY section.)
2. Disengage cargo box lock if installed.
3. Turn key to RUN position.
4. Raise the cargo box by pressing and holding the top of the cargo box power lift switch. Release switch when box is at desired dump height or when reaching maximum height.

NOTE: Allowing the pressure relief valve to open slightly (whine or squeal) after cargo box is fully lowered, helps keep the cargo box secure and reduce rattling caused by travel vibrations.

5. Lower cargo box by pressing and holding bottom of cargo box power lift switch
6. Turn key to STOP position.

Operating the Tailgate

CAUTION: Avoid injury! Never operate tailgate with one lanyard attached (always use both).

Check condition of lanyards for wear or damage. Replace if cable is kinked or frayed.

IMPORTANT: Avoid damage! Do not attempt to tilt or dump cargo box when lanyards are detached. Tailgate damage from contact with hitch results.

To avoid jamming material in the gap between the cargo box bed and tailgate, keep lanyards attached when loading and unloading loose materials.

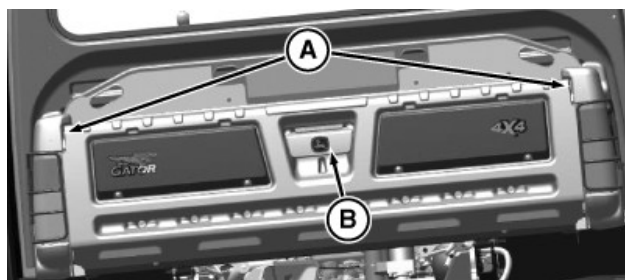

MXT023344—UN—01AUG18

1. Check to be sure lanyards (A) are in place to support lowered tailgate.
2. Disconnect lanyards if you want to lower tailgate more than 90 degrees.

IMPORTANT: Avoid damage! Lower tailgate completely to unload cargo box only. Never drive with the tailgate hanging down. Tailgate can contact tires and cause damage.

3. Pull back on handle (B) to unlock and lower tailgate.
4. Before raising tailgate, check for stones and debris caught in the gap between the tailgate and cargo box floor.

To remove debris:

- a. Lock the cargo box in raised position.
 - b. Rotate the tailgate slightly to free debris, and brush out the gap.
 - c. Lower the cargo box.
5. To raise tailgate, slowly push tailgate upward and lock into closed position.

6. Check to be sure that tailgate is securely locked.

Using Cargo Box Tie Downs

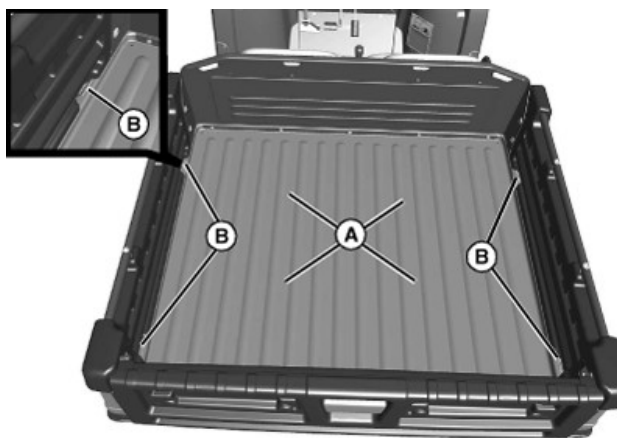

MXAL44173—UN—10APR13

1. Arrange load so the weight is centered over the main cargo area (A).
2. Secure loads to the tie-downs (B) in a safe and secure manner.

Operating

Removing the Tailgate

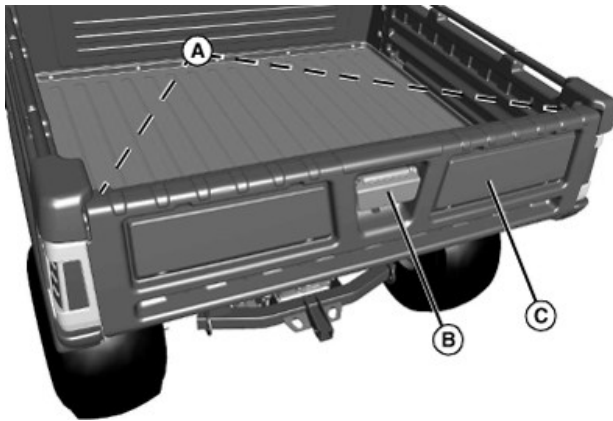

1. Check to be sure lanyards (A) are in place to support lowered tailgate.
2. Pull back on handle (B) to unlock and lower tailgate (C).

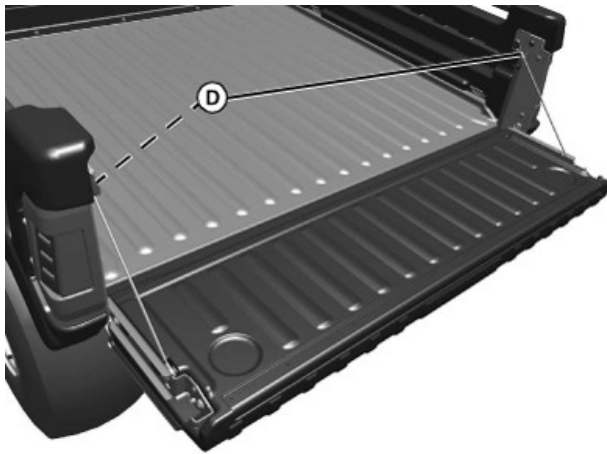

3. Loosen loop (D) on top of lanyards, disconnect from studs on cargo box side, and lower tailgate fully downward.

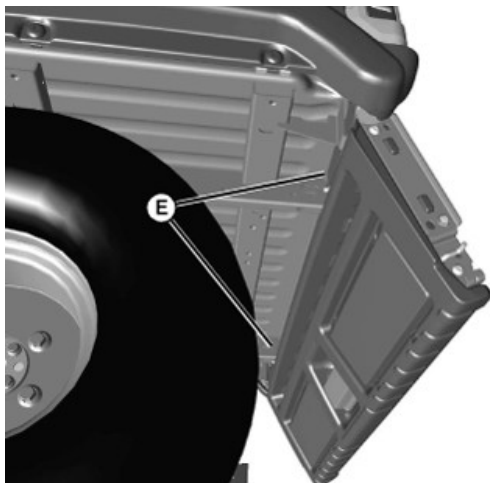

4. Loosen two nuts (E) on rear of floor panel, to allow side panels to be removed.

5. If equipped with tail lights, disconnect the wiring harness and hang the harness in the rear of the box.

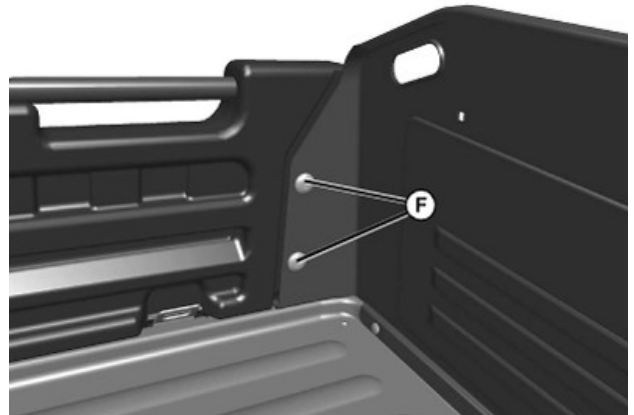

6. From behind drivers seat in cargo box, remove two nuts (F).

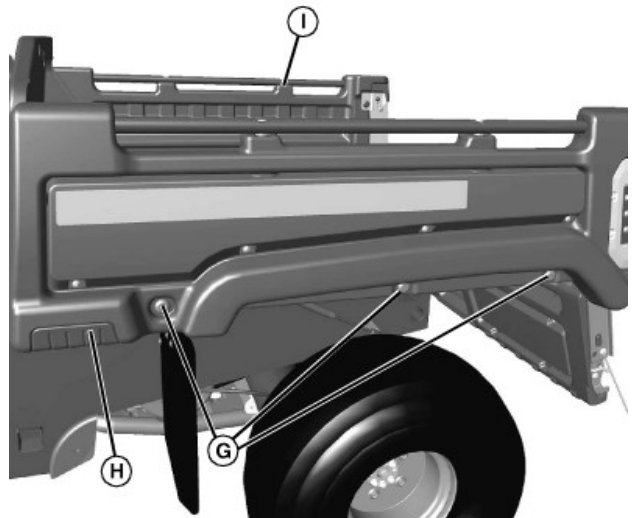

7. Loosen three bolts (G) in left side body panel (H). Do not completely remove bolts from clamp-on nuts.
8. Support the tailgate to avoid bushing damage. Move side body panel slightly outward and remove tailgate from left side body panel and right side body panel (I).
9. Install in reverse order of removal.

Operating in Flat Bed Mode

⚠ CAUTION: Avoid injury! Cargo box load guard protects operator and passenger from shifting loads. Do not remove load guard.

Operating

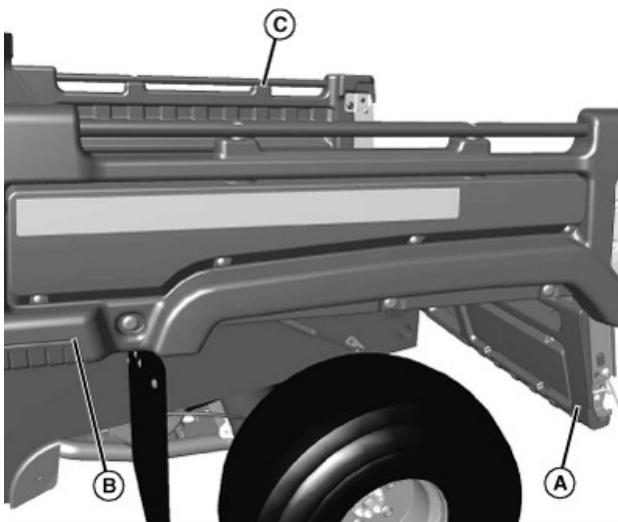

MXAL44179—UN—10APR13

1. To operate machine in flat bed mode, remove tailgate (A) (See Removing the Tailgate).
2. Remove left (B) and right (C) side body panels.

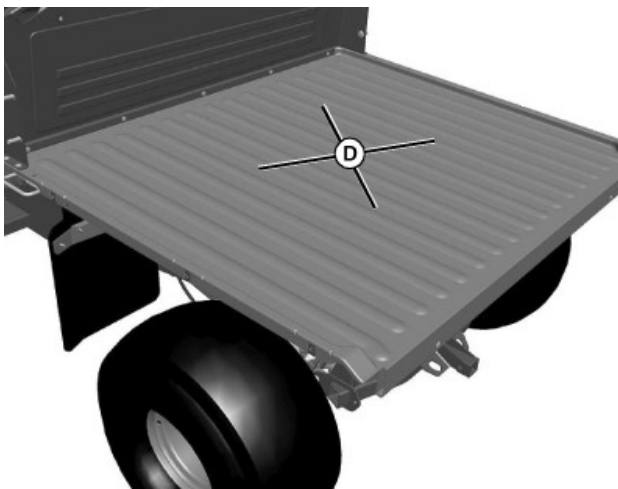

MXAL44180—UN—10APR13

3. Arrange load so the weight is centered over the main cargo area (D).
4. Install tailgate and side panels in reverse order of removal procedure (See Removing the Tailgate).

MX10673.0000084-19-01AUG18

Determining Vehicle Load Capacity

Find weights and capacities for your machine model in the Specifications section.

CAUTION: Avoid injury! Overloading the vehicle or trailer causes loss of control, resulting in serious injury or death.

- Do not allow the Gross Vehicle Weight (GVW) to exceed the Gross Vehicle Weight Rating (GVWR) of the vehicle.

- Remove excess weight before operating vehicle.

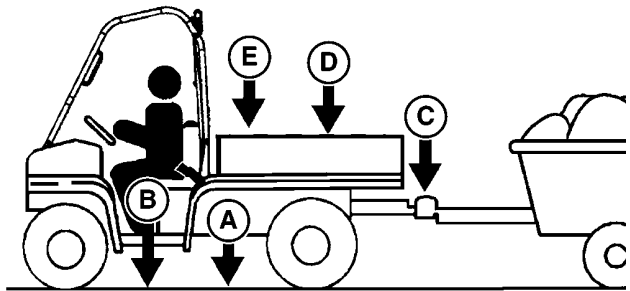

MXT022520—UN—14MAY18

The picture shows a Protective Structure installed on a two-passenger machine. Some machines do not have a Protective Structure installed as some models are not designed to include it.

Factors in Determining Vehicle Load Capacity

NOTE: Optional equipment, and attachments that are not standard equipment, reduce your cargo box capacity; so they must be included when determining gross vehicle weight.

- **Gross Vehicle Weight (GVW)** is the combination of the empty vehicle weight and payload.
- **Gross Vehicle Weight Rating (GVWR)** is the maximum permissible vehicle weight.
- **Payload** is the weight of all occupants, tongue weight, cargo, attachments, and options that were not standard equipment.

$$\text{Payload} = \text{B} + \text{C} + \text{D} + \text{E}$$

- **(A) Empty vehicle weight** is the weight of the vehicle (full fluids) without occupants or load or attachments.
- **(B) Occupant load** is the combined weight of the operator and passenger (or passengers).
- **(C) Trailer tongue weight** is the weight measured if the tongue of a loaded trailer was placed on a scale. The tongue weight must be approximately 10% of the total of the trailer weight and the weight of its load.
- **(D) Cargo load** is the weight of the cargo.
- **(E) Attachment and option weight** is the combined weight of all attachments and options that were not standard equipment. For help with this information, contact your John Deere dealer.
- **Vehicle load capacity** is the remaining amount of weight that the vehicle is able to haul.
- **Determine maximum vehicle load capacity:**
 - a. Calculate $\text{GVW} = \text{A} + \text{B} + \text{C} + \text{D} + \text{E}$
 - b. Subtract the Gross Vehicle Weight (GVW) from the Gross Vehicle Weight Rating (GVWR).
 - c. The weight difference between the two numbers is the vehicle load capacity.

Operating

Vehicle Load Capacity = GVWR-GVW

- d. The Gross Vehicle Weight must be less than or equal to the Gross Vehicle Weight Rating. If GVW exceeds GVWR, remove excess weight from the vehicle before operating.

Example:

The following is for a vehicle with 68 kg (150 lb) of cargo load, a 91 kg (200 lb) operator, 100 kg (220 lb) of attachments. Attachments include a heavy-duty brush guard, Protective Structure poly roof, cargo box power lift kit; towing a trailer with 23 kg (50 lb) of tongue weight.

Find the correct specifications for your machine model in the Specifications section in this manual. To determine your machine capacity, use those numbers.

Key	Description
(A) Empty Vehicle Weight:	553 kg (1220 lb)
(B) Operator Weight:	91 kg (200 lb)
(C) Trailer Tongue Weight:	23 kg (50 lb)
(D) Cargo Load:	68 kg (150 lb)
(E) Attachments and/or Options:	100 kg (220 lb)

GVW = 835 kg (1840 lb)

- 91 kg (200 lb) + 553 kg (1220 lb) + 23 kg (50 lb) + 68 kg (150 lb) + 100 kg (220 lb)

Vehicle Load Capacity = 81 kg (180 lb)

- GVWR 916 kg (2020 lb) less GVW 835 kg (1840 lb)

Utilize the remaining vehicle load capacity of 81 kg (180 lb) to haul an additional passenger (or passengers), cargo, trailer tongue, and attachment weight.

MX10673.000008A-19-07JUN18

Loading the Cargo Box

CAUTION: The utility vehicle may become unstable if the cargo box is loaded incorrectly. Avoid loose and shifting loads or uneven loading of material.

- Do not load above height of load guard.
- Securely anchor all loads in cargo box.
- Do not load beyond maximum capacity.

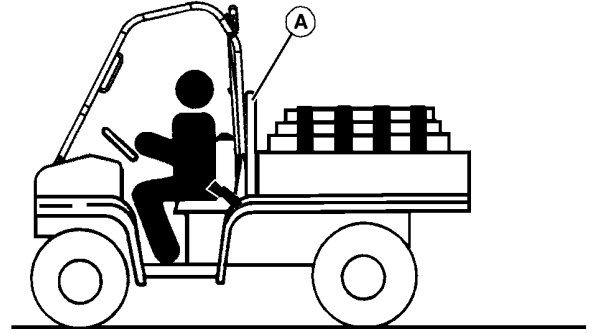

MXAL44182—UN—10APR13

See capacities in SPECIFICATIONS.

Reduce load by half when operating over rough, hilly, or steep terrain. Do not overload vehicle. Limit loads to those that can be safely controlled.

Reduce speed and exercise extreme caution when operating over rough, hilly, or steep terrain.

Securely anchor and evenly distribute loads in cargo box, when loading objects into vehicle. Shifting loads will affect stability.

Do not load above load guard (A).

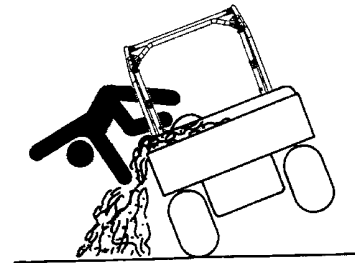

MXAL44183—UN—10APR13

Avoid concentrated loads at rear or side of cargo box to prevent vehicle from tipping over. Be sure load is evenly distributed.

Because there is a big difference in weight between dry and wet sand, the only way of getting true weight of the load you are carrying is by using a scale.

Printed weight is normally on bagged and other material.

Operating

Box Volume Capacity

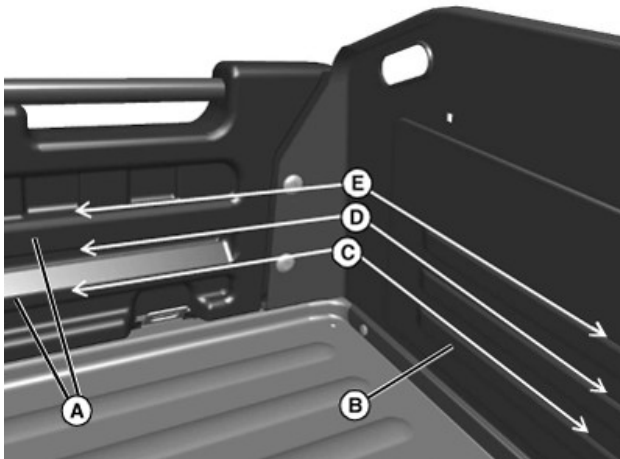

MXAL44184—UN—10APR13

Use rub rails (A) in left and right side panels, and form beads (B) in cargo box front panel to determine cargo box volume.

- 10.1 cm (4 in.) load height (C) = 150 L (5.3 cu ft).
- 15.2 cm (6 in.) load height (D) = 226 L (8 cu ft).
- 20.3 cm (8 in.) load height (E) = 303 L (10.7 cu ft).

NOTE: Use table below to determine height of common cargo box materials.

Do not exceed Gross Vehicle Weight Rating (GVWR).

Material	Estimated Density (lbs/cubic foot)	Capacity Height
Asphalt	45	12
Brick	120	6
Cement (Dry)	94	8
Sand (Dry)	100	7
Sand (Damp)	120	6
Sandstone (Broken)	94	8
Concrete (Set/Mix)	135	5
Soil (Dry/Loose)	78	9
Soil (Wet/Packed)	100	7
Clay (Dry/Lump)	67	11
Clay (Wet/Lump)	100	7
Fertilizer	60	12
Gravel (1/4 - 2 in.)	105	7
Turf/Sod	35	12

MX10673,000008B-19-12SEP17

Emptying Cargo Box

CAUTION: Raising a loaded cargo box changes the center of gravity. Keep vehicle a safe distance from the edge of ravine or drop-off when raising cargo box to empty.

A loaded cargo box can be very heavy. Do not attempt to manually raise a loaded cargo box. Unload cargo box before raising it by hand.

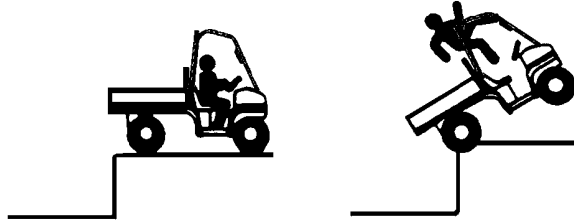

MXAL44185—UN—10APR13

1. Back up vehicle to dump site.
2. Park the vehicle safely. (See Parking Safely in the SAFETY section.)
3. Open tailgate.

IMPORTANT: Stop emptying immediately if overload pressure relief valve opens. Lower cargo box completely and remove excess load by hand before dumping.

4. Raise cargo box to dump load.
5. Lower cargo box when empty.
6. Close tailgate. Do not drive vehicle with cargo box in raised position.

MP47322,00F4854-19-03APR13

Towing Loads

CAUTION: Avoid injury! Excessive towed load can cause loss of traction and loss of control on slopes. Stopping distance increases with speed and weight of towed load.

Do not tow a load that exceeds the maximum allowable towing load for this vehicle, as specified in this operator's manual.

Secure towed loads before transporting.

- To provide adequate braking ability and traction, the weight of the towing vehicle (base vehicle + vehicle payload) should be at least 1.5 times the weight of the towed load (trailer + trailer payload).
- When operating over rough, hilly, or steep terrain and reducing cargo load by half, any towed load should also be reduced accordingly.
- Do not tow a load that exceeds towing capacity listed in SPECIFICATIONS.
- Do not exceed trailer tongue weight listed in SPECIFICATIONS.

Operating

- Tow load at a speed slow enough to maintain control.
- Towing heavy loads in high gear will reduce CVT belt life.

IMPORTANT: Avoid damage! When operating on terrain with extreme angles, use a ball type hitch (A).

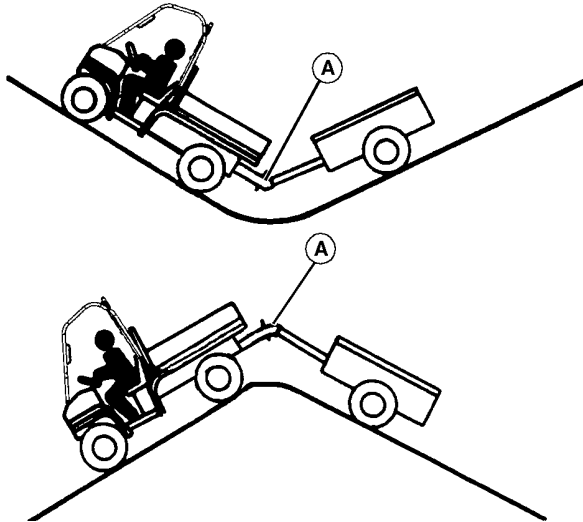

MXAL44186—UN—10APR13

- Always use approved hitch and hitch point provided for the utility vehicle. Do NOT modify the hitch or hitch point in any way.

Capacity Label

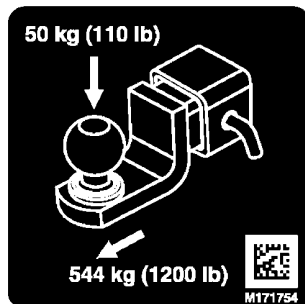

MXT007935—UN—18JUL13

Labels shown are for reference only. Confirm capacities on labels on your machine.

Your machine may have a hitch capacity label installed near the hitch area. The label indicates vertical and horizontal load capacities.

The vertical load capacity is the maximum down force which can be applied for safe operation. The horizontal

load capacity is the total weight of what is being towed which must not be exceeded for safe operation.

MX10673.000008C-19-12SEP17

Using Correct Tires and Inflation

CAUTION: Help prevent severe bodily injury or death, failure to observe these recommendations may result in loss of stability and operator control.

See tire descriptions and inflation pressures for load conditions in SPECIFICATIONS.

Tires

Use of John Deere approved original equipment or optional equipment is recommended. To ensure maximum machine performance and ride quality, do not mix size, type, or placement of tires. Failure to place tires per the guidelines could result in reduced machine performance, diminished traction and poor handling.

Inflation

CAUTION: Explosive separation of tire and rim parts is possible when they are serviced incorrectly:

- Do not attempt to mount a tire without the proper equipment and experience to perform the job.
- Do not inflate the tires above the recommended pressure.
- Do not weld or heat a wheel and tire assembly. Heat can cause an increase in air pressure resulting in an explosion. Welding can structurally weaken or deform the wheel.
- Do not stand in front or over the tire assembly when inflating. Use a clip-on chuck and extension hose long enough to allow you to stand to one side.

IMPORTANT: Over inflation may damage tires and diminish ride quality. Under inflation could cause wheel damage when riding over rough terrain.

An accurate low pressure gauge is available at your John Deere dealer.

MP47322.00F4856-19-03APR13

Tire Chains

IMPORTANT: Tire chains are not approved for use on this vehicle.

MP47322.00F4857-19-03APR13

Operating

Transporting Machine

Towing the Machine

IMPORTANT: Avoid damage! Never tow the vehicle above 40 km/h (25 mph); towing a vehicle at speeds above 40 km/h (25 mph) results in transmission damage.

To avoid damage, haul the vehicle in an enclosed trailer. If an open trailer must be used, haul on a heavy-duty trailer or on a full-size truck. Be cautious and travel at reduced speeds.

Optional accessories, such as a windshield, should be removed to avoid sudden unintentional separation from the vehicle.

Never use a car type dolly with the front wheels on the dolly.

1. Check to be sure that the ignition key switch is in the STOP position.
2. Make sure that the 2WD/4WD switch is in the 2WD position.
3. Unlock the park brake and move the transaxle shift lever to the neutral (N) position for towing.

Machine Tie-Down Locations

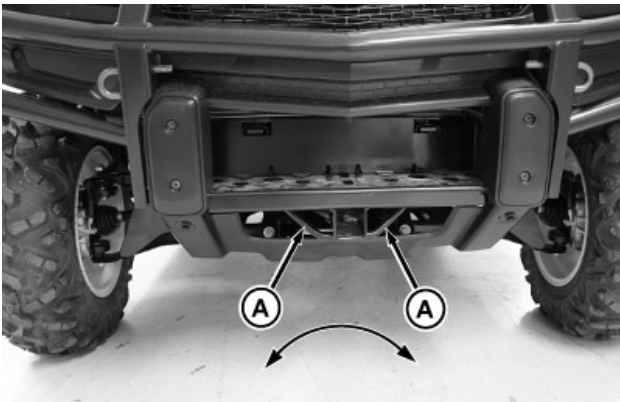

MXT018981—UN—04JAN17

- Fasten the front of the machine through tie-down points (A) on the front of the machine to trailer with a heavy-duty strap, chain, or cable. Strap must be directed down and outward from machine.

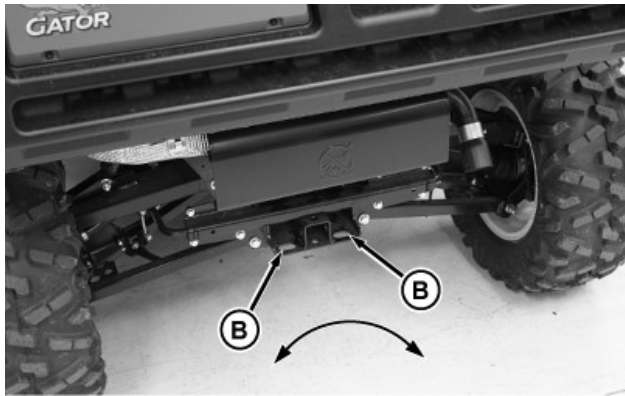

MXT018982—UN—04JAN17

- Fasten the rear of the machine through tie-down points (B) on the rear of the machine to trailer with a heavy-duty strap, chain, or cable. Strap must be directed down and outward from machine.

Hauling the Machine

NOTE: Space limitations can vary from one truck manufacturer to another. Short bed trucks do not have the necessary length requirement to accommodate the machine.

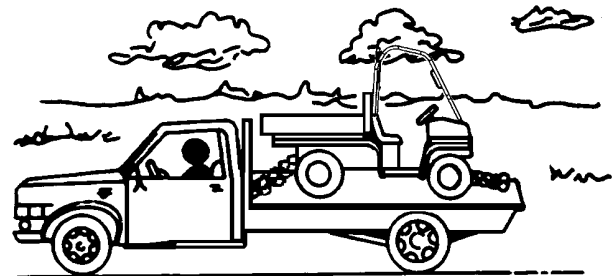
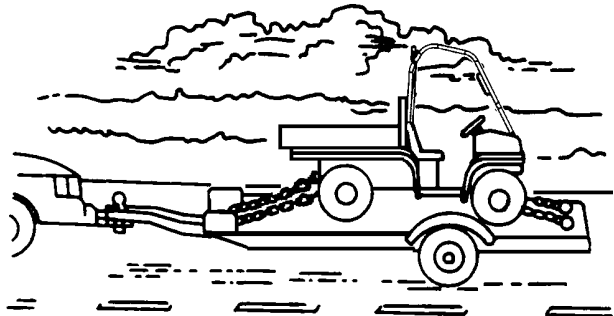

MXAL44189—UN—10APR13

1. Back machine onto the trailer or truck.
2. Leave transaxle shift lever in forward or reverse gear.
3. Park machine safely. (See Parking Safely in the SAFETY section.)
4. Fasten machine to trailer or truck with straps, chains, or cables.
5. Equip the trailer or truck with all the necessary lights

Operating

and signs required by local, state, provincial, or federal laws.

6. Remove or secure optional attachments, if equipped.

OUMX068,00011FF-19-04JAN17

Optional Attachments & Kits

Attachments and Kits

NOTE: All attachments and kits are not shown. Attachments and kits vary by machine model and may not be available in all regions. Specifications and design are subject to change without notice. See your John Deere dealer for availability in your region.

MX00654.00000E3-19-04SEP13

Backup Alarm

Periodically Check Alarm Function

1. Start machine.
2. Move transmission shift lever into Reverse gear and listen for alarm.
3. Contact your John Deere dealer if alarm does not function properly.

MP47322.00F485C-19-03APR13

Front Receiver Hitch

Using Hitch

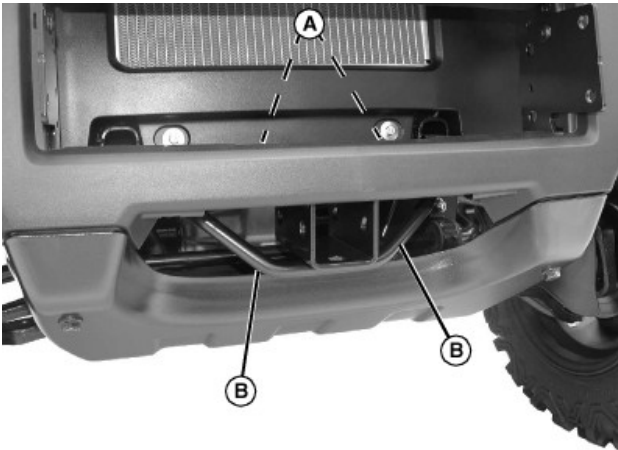

MXAL44203—UN—10APR13

1. Mount front accessories into holes (A) in front receiver hitch.
2. Use rings (B) as needed.

MP47322.00F485F-19-03APR13

Cargobox Toolboxes

IMPORTANT: Avoid damage! Toolbox lids open to the side may be damaged by contact with objects when operating the machine. Before operating the machine, check to be sure that the toolbox lids are closed and the latches are secure.



MXT015592—UN—15SEP15

Check to be sure toolbox lids which open to the side (A) are closed before operating machine.

Operating the Tailgate

CAUTION: Avoid injury! Riders can fall off and be injured or killed. Do not allow riders in the cargo box or on the tailgate.

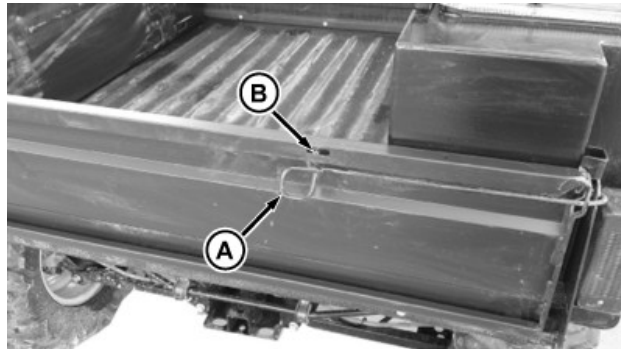

MXT015581—UN—14SEP15

1. To unhook rods from slot (B) in tailgate, push in and down on loop (A) of tailgate latch rods.
2. Pull latch rods out and down.

CAUTION: Avoid injury! When raising or lowering tailgate, latch rods can swing outward abruptly towards operator. Stand in center of tailgate and slowly lower or raise tailgate to make sure that latch rods do not contact operator.

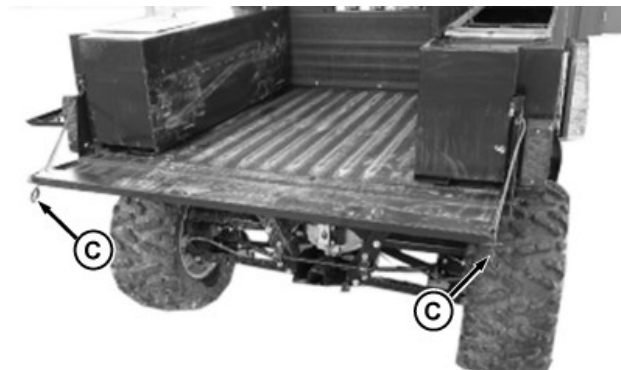

MXT015582—UN—17SEP15

3. Lower tailgate until it rests on ends of latch rods (C).

Optional Attachments & Kits

IMPORTANT: Avoid injury! Lower tailgate completely to unload cargo box only. Never drive with the tailgate hanging down. Tailgate can contact tires and cause damage.

4. To engage rod in slot (B) in tailgate raise tailgate, slowly push tailgate upward. Push inward and upward on loop (A) of latch rod.

Removing the Tailgate

⚠ CAUTION: Avoid injury! Riders can fall off and be injured or killed. Do not allow riders in the cargo box or on the tailgate.

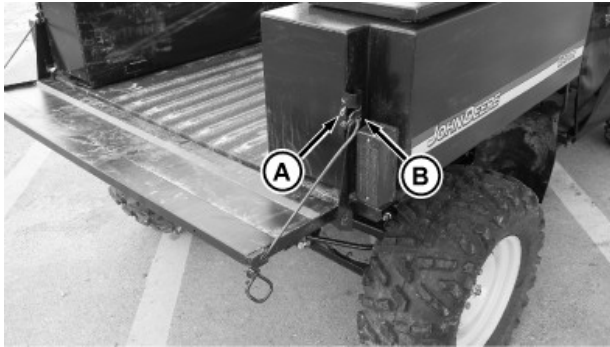

MXT015583—UN—14SEP15

1. Remove and retain rubber hose sleeves from latch rod ends (A).
2. To disengage from slots (B) in cargo box sides, raise tailgate slightly and rotate latch rods.
3. Remove latch rods from sides of tailgate.
4. Support tailgate by hand.

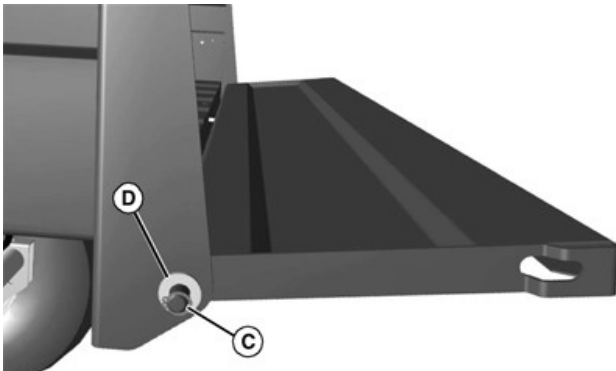

MXAL47430—UN—12APR13

5. Remove retaining ring (C) and bushing (D) from each tailgate rod end.
6. Slide tailgate sideways so tailgate rod end is clear of the cargo box bracket.
7. Pull the detached end of tailgate away from the cargo box enough to clear the cargo box bracket. Allow the tailgate to slide in opposite direction to complete removal.
8. To install, reverse the steps.

OOU2004,0000CF5-19-17SEP15

Using a Trailer

Follow all trailer manufacturers instructions for safe operation.

Follow all instructions in this Operators Manual for attaching optional equipment and towing loads safely.

MP47322,00F4860-19-23JUN15

Service Intervals

Servicing Your Machine

IMPORTANT: Operating in extreme conditions may require more frequent service intervals:

- Engine components may become dirty or plugged when operating in extreme heat, dust or other severe conditions.
- Engine oil can degrade if machine is operated constantly at slow or low engine speeds or for frequent short periods of time.

Please use the following timetables to perform routine maintenance on your machine.

Park the vehicle safely. See Park Safely in the SAFETY Section.

MP47322,00F464B-19-15MAR13

Break In

After First 8 Hours:

- Check and tighten wheel bolts to correct torque.
- Check brake fluid level.
- Check alignment of glass cab doors, if equipped. (See your John Deere dealer for this service.)

SB31882,000029D-19-31AUG18

Every 50 Hours or Annually

- Check brake fluid level, lines and connections.
- Lubricate drive line.
- Check 4WD front differential oil level.
- Check transaxle oil level.
- Inspect driveline CV boots for tears or punctures.
- Inspect park brake for proper function. (See your John Deere dealer for any adjustments needed.)
- Grease cargo box tailgate strikers.

MX10673,0000054-19-02AUG17

Every 200 Hours or Annually (whichever comes first)

- Change engine oil and filter.
- Change fuel filter.
- Check HVAC filter - if equipped.
- Check air cleaner dust unloading valve.
- Check HVAC dust unloading valve - if equipped.
- Clean radiator.
- Check drive belt condition.
- Inspect and clean primary and secondary clutch.
- Check compressor idler bearing - if equipped.

- Inspect compressor belt - if equipped.
- Inspect alternator belt.
- Inspect battery. Clean if necessary.
- Check toe-in.
- Check brake pad wear.
- Check park brake oil level.
- Check and tighten wheel bolts to correct torque.
- Check/clean spark arrestor if equipped.
- Check and tighten all hardware.
- Inspect cargo box lanyards.

MX10673,0000058-19-02AUG17

Every 400 Hours or 24 Months (whichever comes first)

- Inspect ball joints for play.
- Inspect suspension bushings for play. (See your John Deere dealer for this service.)
- Inspect wheel bearings for play. (See your John Deere dealer for this service.)

MX10673,0000056-19-02AUG17

Every 800 Hours or 24 Months (whichever comes first)

- Change transaxle oil.
- Change 4WD front differential oil.
- Replace drive belt.

MX10673,0000057-19-02AUG17

Every 1000 Hours or 24 Months (whichever comes first)

- Flush and refill brake fluid. (See your John Deere dealer for this service.)
- Inspect shocks and struts for leaks.
- Change engine coolant.

MX10673,0000055-19-02AUG17

Service Lubrication

Grease

IMPORTANT: Avoid Damage! Use recommended John Deere greases to avoid component failure and premature wear.

The following grease is recommended for service:

- John Deere Multi-Purpose HD Lithium Complex Grease
- Grease-Gard™ Premium Plus

Not all grease types are compatible; John Deere does not recommend mixing greases. If using any product other than the recommended grease in service, purge any remaining grease from the system prior to application. If this is not practical, grease twice as often until all old grease is purged from the system.

OUMX068,0000642-19-27AUG14

Lubricating Drive Line

1. Park the machine safely. (See Parking Safely in the SAFETY section.)

NOTE: To line up the grease fitting with the hole in the driveshaft cover, move the machine by hand to rotate shaft (B).

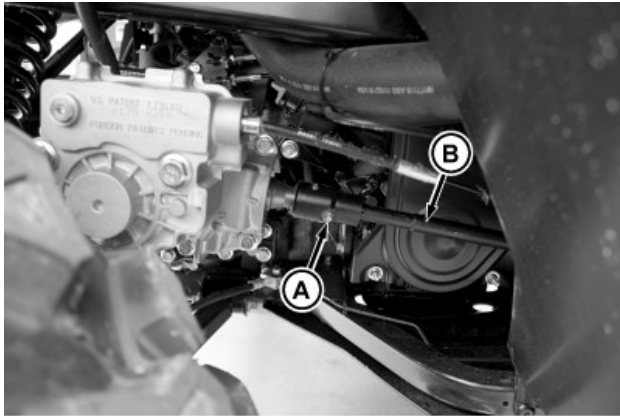

MXT018984—UN—04JAN17

Picture Note: View from right rear side of vehicle.

2. Lubricate grease fitting (A) on rear driveshaft coupler with one or two shots of grease.

OUMX068,0001201-19-09SEP17

Service Engine

Emissions Service Information

A qualified repair shop or person of the owner's choosing may maintain, replace, or repair emission control devices and systems with original or equivalent replacement parts. However, warranty, recall and all other services paid for by John Deere must be performed at an authorized John Deere service center.

Within the warranty period, John Deere will reimburse reasonable service costs incurred at service providers outside the John Deere authorized network only in an unsafe, emergency condition if an authorized John Deere dealer is not available and the failure does not arise from the owner's misuse or failure to perform required maintenance. An emergency situation exists under this section if, after 30 days, the authorized John Deere network is unable to perform the repairs or source replacement parts.

Emission Control System Certification Label

NOTE: Tampering with emission controls and components by unauthorized personnel may result in severe fines or penalties. Emission controls and components can only be adjusted by EPA and/or CARB authorized service centers. Contact your John Deere Retailer concerning emission controls and component questions.

The presence of an emissions label signifies that the engine has been certified with the United States Environmental Protection Agency (EPA) and/or California Air Resources Board (CARB).

The emissions warranty applies only to those engines marketed by John Deere that have been certified by the EPA and/or CARB; and used in the United States and Canada in off-road mobile equipment.

Altitude Adjustment (Gasoline or Propane Converted Engines Only)

If your engine features a carburetor it is calibrated by the engine manufacturer and is not adjustable.

If your engine is operated at altitudes below 610 m (2,000 ft.), a high altitude carburetor jet kit is not required. If your engine is operated at altitudes above 610 m (2,000 ft.), a high altitude carburetor jet kit may be required for proper engine performance and emissions control. Operating the engine with the wrong carburetor configuration at a given altitude may increase the engine's emissions and decrease fuel efficiency and performance.

See a qualified service provider for details on jet kit requirements for your specific product.

TC00531,00000EC-19-28MAR16

Avoid Fumes

CAUTION: Engine exhaust fumes contain carbon monoxide and can cause serious illness or death.

- Move the machine to an outside area before running the engine.
- Do not run an engine in an enclosed area without adequate ventilation.
- Connect a pipe extension to the engine exhaust pipe to direct the exhaust fumes out of the area.
- Allow fresh outside air into the work area to clear the exhaust fumes out.

MX00654,00000C2-19-24AUG13

Diesel Engine Oil

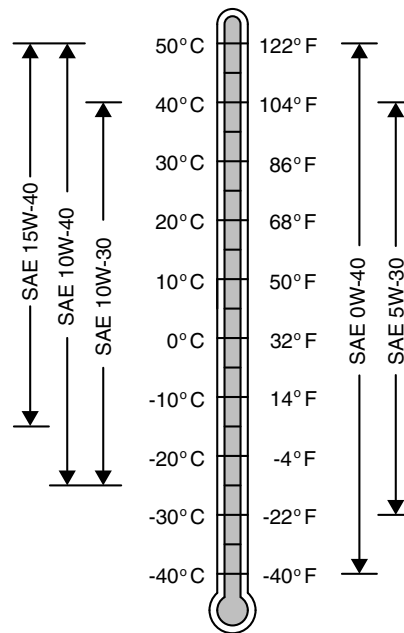

TS1691—UN—18JUL07

Oil Viscosities for Air Temperature Ranges

Failure to follow applicable oil standards and drain intervals can result in severe engine damage that might not be covered under warranty. Warranties, including any emissions warranty, are not conditioned on the use of John Deere oils, parts, or service.

Use oil viscosity based on the expected air temperature range during the period between oil changes.

John Deere Plus-50™ II is the recommended engine oil.

If John Deere Plus-50™ II engine oil is not available, engine oil meeting one or more of the following may be used:

Plus-50 is a trademark of Deere & Company

Service Engine

- API Service Category CD or higher
- ACEA Oil Sequence E3 or higher

DO NOT use engine oil containing more than 1.0% sulfated ash, 0.12% phosphorus, or 0.4% sulfur.

Multi-viscosity diesel engine oils are preferred.

Diesel fuel quality and fuel sulfur content must comply with all existing emissions regulations for the area in which the engine operates.

IMPORTANT: Avoid damage! Use only ultra-low sulfur diesel (ULSD) fuel with a maximum sulfur content of 15 mg/kg (15 ppm).

MK71445,000007F-19-14JUN18

Checking Engine Oil Level

IMPORTANT: Avoid damage! Failure to check the oil level regularly could lead to a serious engine problem when the oil level is out of the operating range:

- Check oil level before operating.
 - Check oil level when the engine is cold and not running.
 - Keep oil level between the dipstick marks.
 - Shut off engine before adding oil.
1. Park the vehicle safely. (See Parking Safely in the SAFETY section.)
 2. Raise and secure cargo box.

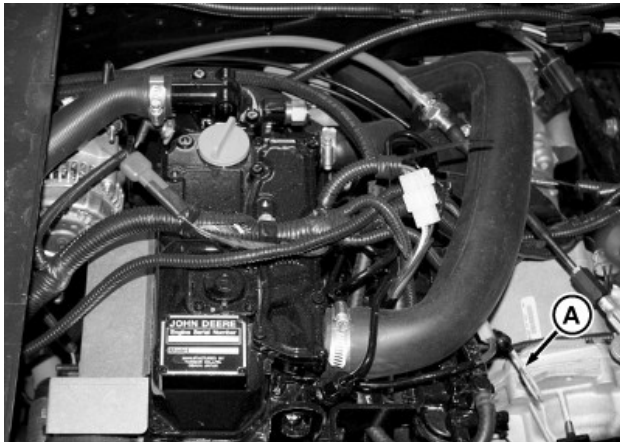

MXT019796—UN—10JAN17

3. Remove dipstick (A) and wipe it clean.
4. Install dipstick.
5. Remove dipstick.
6. Check oil level:
 - Oil level must be between fill marks on dipstick.

- If oil level is low, add oil to bring oil level no higher than upper mark on dipstick.
- If oil level is above the upper mark, drain to the proper level. Determine cause of this condition and correct.

7. Install dipstick.
8. Lower the cargo box.

OUMX068,000120B-19-10JAN17

Changing Engine Oil and Filter

IMPORTANT: Avoid damage! Change the oil more often when the vehicle is used in extreme conditions:

- Dusty conditions.
- Frequent slow or low-speed operation.
- Frequent short trips.

1. Run engine to warm the oil.
2. Park the vehicle safely. (See Parking Safely in the SAFETY section.)
3. Raise and secure cargo box.
4. Place drain pan under the engine drain plug.

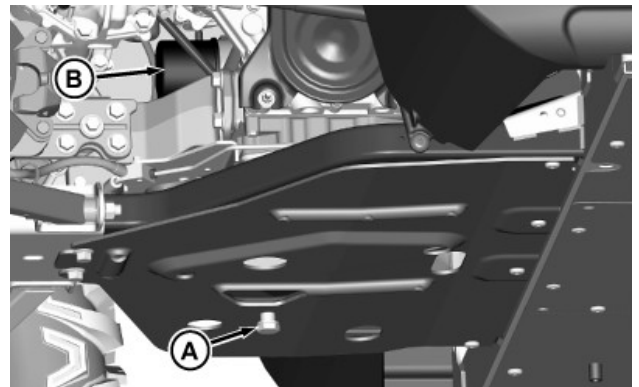

MXT019797—UN—10JAN17

View from under right (passenger) side.

5. Remove drain plug (A) on the bottom of engine and drain oil into the oil drain pan. Allow oil to drain completely.
6. Remove and discard oil filter (B) on the front of engine. Allow oil to drain into the drain pan.
7. Wipe off oil filter base on engine.
8. Put a light coat of clean engine oil on gasket of the new oil filter. Install new filter until rubber gasket contacts filter base. Tighten filter an additional one-half turn.
9. Install drain plug.

Service Engine

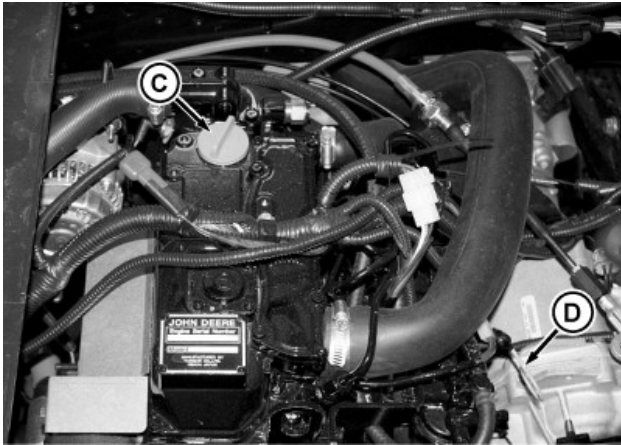

MXT019798—UN—10JAN17

10. Remove oil fill cap (C) from filler opening.

IMPORTANT: Avoid damage! Do not overfill the crankcase with oil. Oil capacities given are with engine and crankcase dry. Some oil remains in engine after draining.

11. Add oil no higher than upper mark on dipstick (D).
12. Install oil fill cap.
13. Start and run engine at idle to check for leaks. Stop engine. Fix any leaks before operating.
14. Check oil level, add oil if necessary.
15. Lower the cargo box.

OUMX068,000120C-19-10JAN17

Cleaning Dust Unloading Valve

IMPORTANT: Do not operate engine without air cleaner element and rubber dust unloading valve installed.

1. Park the vehicle safely. (See Parking Safely in the SAFETY section.)
2. Allow engine to cool.

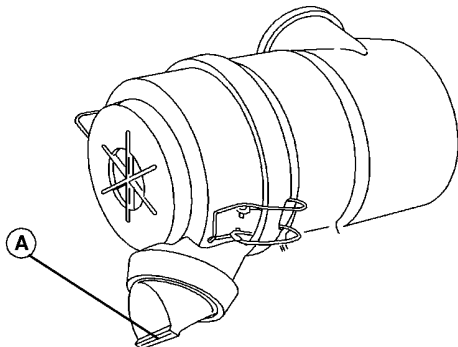

MXAL44211—UN—10APR13

3. Squeeze dust unloading valve (A) to clean. Remove and replace if damaged.

MP47322,00F4873-19-03APR13

Servicing Air Cleaner Element

IMPORTANT: Avoid damage! Dirt and debris can enter engine when air cleaner canister is opened. To keep contamination of the intake system to a minimum, do not open canister unless required for scheduled service.

Check filter element more frequently when operating in dusty conditions.

1. Park the vehicle safely. (See Parking Safely in the SAFETY section.)
2. Allow engine to cool.

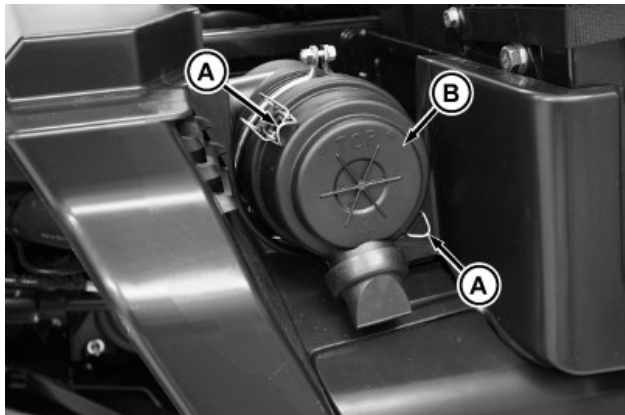

MXT019799—UN—11JAN17

3. Release latches (A) and remove air cleaner cover (B).

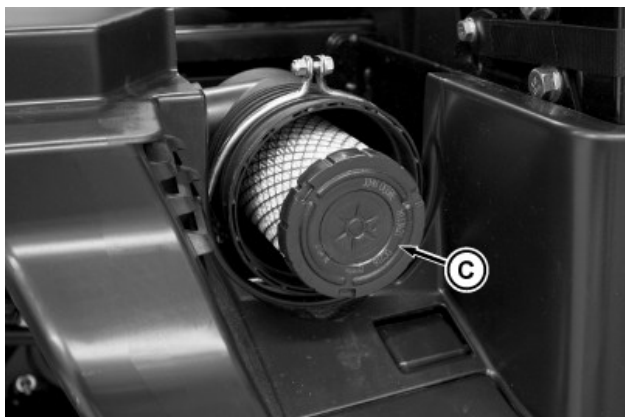

MXT019800—UN—11JAN17

4. Remove and discard primary filter element (C).

Service Engine

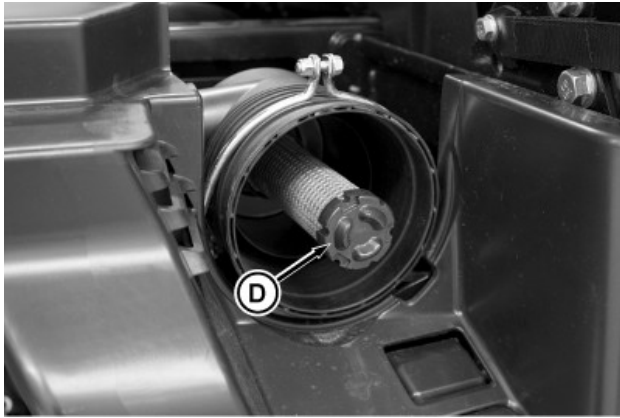

MXT019801—UN—11JAN17

5. Remove and discard secondary filter element (D).
6. Install new secondary filter element.
7. Install new primary filter element.
8. Install air cleaner cover with rubber dust unloading valve pointing downward. Check instruction molded into canister cover for proper installation.
9. Hook the canister cover latches.

OUMX068,000120D-19-12JAN17

Checking Air Intake Hoses and Clamps

1. Park the machine safely. (See Parking Safely in the SAFETY section.)
2. Allow engine to cool.
3. Raise and secure cargo box.

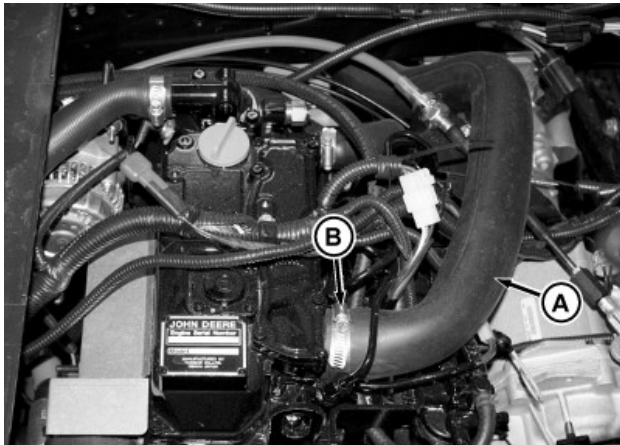

MXT019802—UN—11JAN17

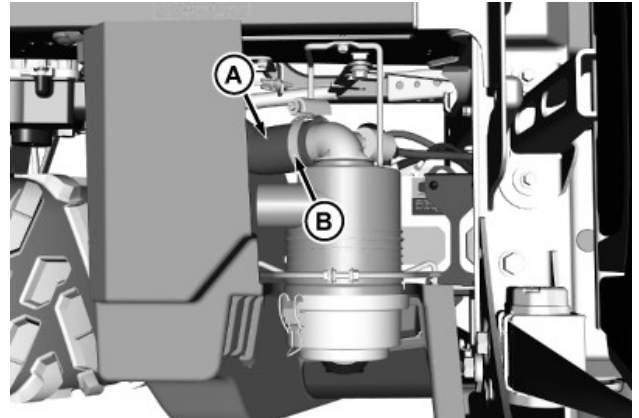

MXT020789—UN—31AUG17

4. Check intake hoses (A) for damage or cracking. Replace if necessary.
5. Check and tighten hose clamps (B) as needed.
6. Lower the cargo box.

OUMX068,000120E-19-31AUG17

Servicing Sediment Bowl

⚠ CAUTION: Fuel vapors are explosive and flammable:

- Do not smoke while handling fuel.
- Keep fuel away from flames or sparks.
- Shut off engine before servicing.
- Cool engine before servicing.
- Work in a well-ventilated area.
- Clean up spilled fuel immediately.

1. Park the vehicle safely. (See Park Safely in the SAFETY section.)
2. Allow engine to cool.
3. Raise and secure cargo box.

Service Engine

Checking



MXAL44558—UN—28MAR13

1. Check for water in sediment bowl (A):
 - Red ring will float on top of the water.
2. If necessary, clean bowl and replace filter.

Cleaning

1. Close fuel shut-off valve (B).
2. Turn collar (C) to remove bowl (A).
3. Remove filter from inside bowl. Discard filter.

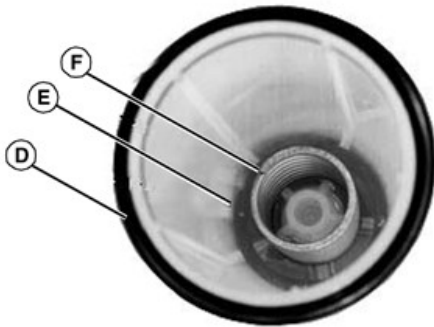

MXAL44559—UN—28MAR13

4. Remove and retain O-ring (D), float ring (E), and spring (F) from bowl. Clean bowl and allow drying.
5. Install O-ring, float ring, spring, and new filter into bowl.
6. Install bowl to filter head and tighten collar to secure.
7. Open fuel shut-off valve.
8. Lower the cargo box.
9. Bleed fuel system.

MX00654.000010A-19-06SEP13

Bleeding Fuel System

IMPORTANT: Modification or alteration of injection pump, pump timing, or fuel injectors in a manner not recommended by the manufacturers will terminate the warranty obligation to the purchaser.

DO NOT attempt to service injection pump or fuel injectors yourself. Special training and special tools are required. See your John Deere dealer.

Bleed air from fuel system:

- After servicing fuel system.
 - If you run out of fuel.
1. Make sure there is fuel in the tank.
 2. Open fuel shut-off valve on filter.

NOTE: If fuel filter has been cleaned or changed, fuel will be heard immediately returning to tank when primer lever is operated. Continue operating lever until you can hear the return flow stop and then start again.

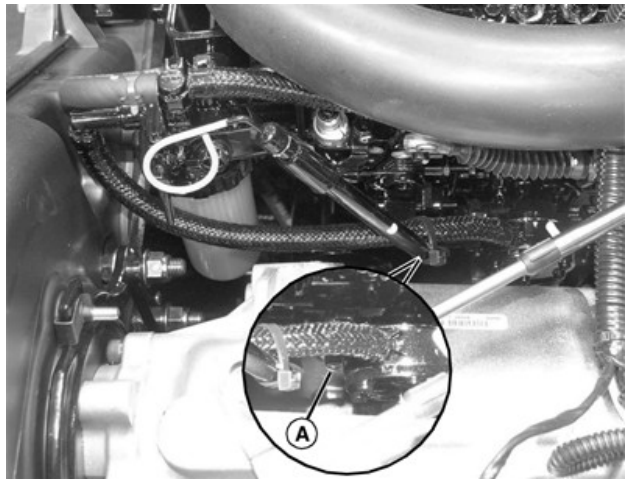

MXAL44560—UN—28MAR13

3. Access fuel pump primer lever (A) from underneath on right side. Move lever up and down. Continue operating lever until:
 - Fuel filter bowl is full of fuel.
 - You can hear fuel returning to tank through return hose.

MX00654.000010B-19-06SEP13

Servicing Fuel Injection Pump

IMPORTANT: Fuel injection pump is calibrated by the engine manufacturer and should not be adjusted.

Do not clean a warm fuel injection pump with steam or water.

Service Engine

Changing injection pump in any way not approved by the manufacturer will end warranty. See your John Deere warranty on this machine.

Do not service injection pump. See your John Deere dealer for service.

If engine is difficult to start, lacks power, or runs rough, check the TROUBLESHOOTING section of this manual. If your engine is still not performing correctly, contact your John Deere dealer.

MX00654,000010C-19-06SEP13

Servicing Fuel Injection Nozzles

IMPORTANT: Do not service or remove fuel injection nozzles. Service life of injection nozzles may be shortened by overheating, improper operation, poor fuel quality, or excessive idling.

Incorrectly functioning, or dirty injection nozzles, will cause the engine to run poorly. See your John Deere dealer for service.

MX00654,000010D-19-06SEP13

Cleaning Engine Compartment

CAUTION: Avoid injury! Touching hot surfaces can burn skin. The engine, components, and fluids are hot when the engine has been running. Allow the engine to cool before servicing or working near the engine and components.

1. Park the vehicle safely. (See Parking Safely in the SAFETY section.)
2. Allow the engine to cool.
3. Raise and secure cargo box.

CAUTION: Avoid injury! Compressed air can cause debris to fly a long distance.

- Clear work area of bystanders.
- Wear eye protection when using compressed air for cleaning purposes.
- Reduce compressed air pressure to 210 kPa (30 psi).

IMPORTANT: Avoid damage! High-pressure water can damage seals, gaskets, and force water into electrical connectors. Use water from a hose or pressure washer with pressures less than 420 kPa (60 psi).

4. Remove any debris in engine compartment, especially around exhaust components:

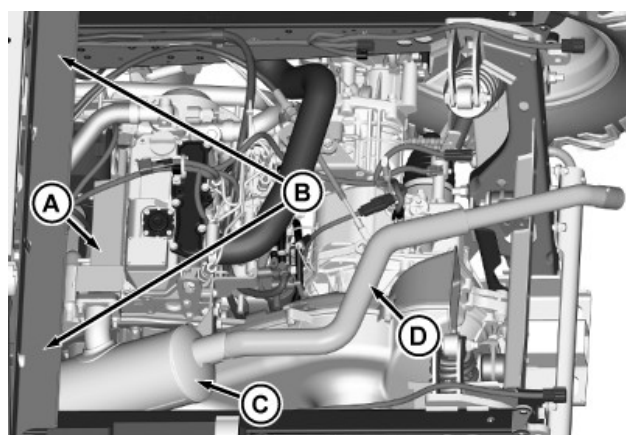

MXT019804—UN—11JAN17

- Keep exhaust manifold (A) and the top of the compartment closeout panel (B) clear of any debris.
- Keep muffler (C) and exhaust pipe (D) clear of any debris.

5. Check and remove any obstructions around the control cables and linkages.

OUMX068,000120F-19-11JAN17

Cleaning Radiator Cooling Fins (Without HVAC)

CAUTION: Avoid injury! Compressed air can cause debris to fly a long distance.

- Clear work area of bystanders.
- Wear eye protection when using compressed air for cleaning purposes.
- Reduce compressed air pressure to specification.

Specification

Air—Pressure. 210 kPa (30 psi)

IMPORTANT: Avoid damage! Cooling fins must be clean to prevent engine from overheating and to allow adequate air intake.

1. Park the vehicle safely. (See Parking Safely in the SAFETY section.)
2. Open hood.

IMPORTANT: Avoid damage! High-pressure water or air can damage cooling fins or other engine components. Use water from a hose or reduce compressed air pressure to 210 kPa (30 psi). Turn off engine before cleaning radiator screen and fins.

Service Engine

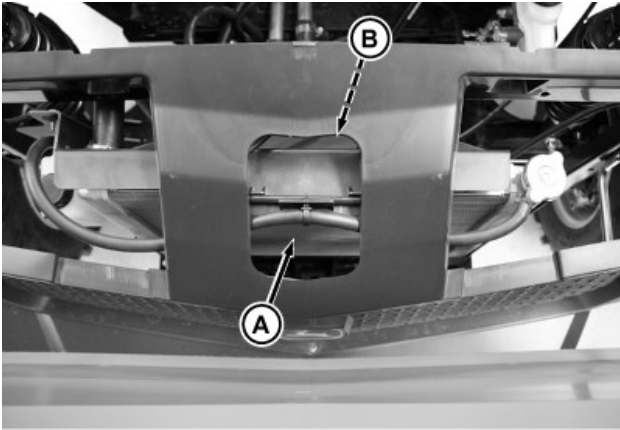

MXT019794—UN—09JAN17

3. Remove all dirt and debris from radiator fins (A) and fan shroud (B) using compressed air or water. Flow of compressed air or water must be from back to front.
4. Close hood.

OUMX068,0001207-19-09JAN17

Checking Coolant Level

1. Park the vehicle safely. (See Parking Safely in the SAFETY section.)
2. Allow engine to cool.
3. Open hood.

NOTE: Models without HVAC have the recovery tank mounted on the right side of the radiator. Models with HVAC have the recovery tank mounted on the left side of the radiator.

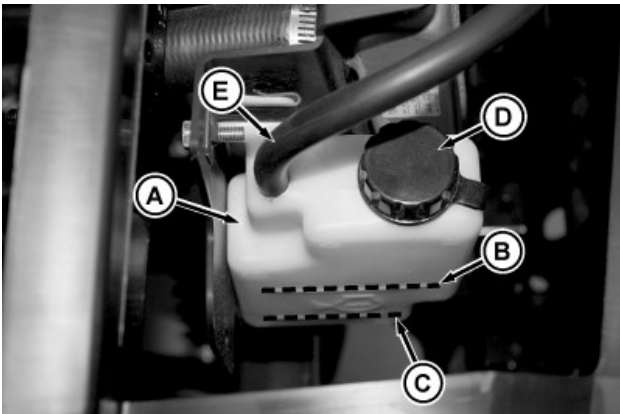

MXT019806—UN—12JAN17

Viewed from the right front side of the machine.

4. Check recovery tank (A) coolant level:
 - If engine is warm, coolant level should be between the FULL line (B) and the LOW line (C).
 - If engine is cold, coolant level should be at the LOW line (C) on the recovery tank.

5. Remove recovery tank cap (D) if necessary to add coolant.
6. Add coolant mixture to the recovery tank.

IMPORTANT: Avoid damage! Installing suction hose (E) incorrectly does not allow coolant into the coolant system. Do not allow the bottom of the hose to touch bottom of bottle or bend upwards out of coolant.

7. Install and tighten recovery tank cap.
8. Close hood.

OUMX068,0001208-19-12JAN17

Service Cooling System Safely

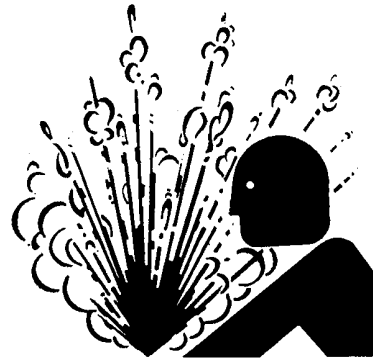

MXAL42730—UN—22MAR13

CAUTION: Avoid injury! The radiator is hot and burns skin. Built-up pressure causes explosive release of coolant when the radiator cap is removed:

- Shut off the engine and allow to cool.
- Do not remove the cap unless the radiator and the engine are cool enough to touch with bare hands.
- Slowly loosen the cap to the first stop to release all pressure. Then remove the cap.

MX00654,0000028-19-25MAR15

Servicing Cooling System

IMPORTANT: Avoid damage! Follow all service procedures exactly. If not equipped to perform this work, see your John Deere dealer for service.

Prepare Vehicle

1. Park the machine safely. (See Parking Safely in the SAFETY section.)
2. Raise cargo box.
3. Open hood.

Service Engine

4. Remove the storage tub under the hood, if equipped.
5. When the coolant system service is completed:
 - Install the storage tub under the hood, if equipped.
 - Close hood.
 - Lower cargo box.

Draining Cooling System

1. Make sure that engine has cooled completely.

CAUTION: Avoid injury! The radiator is hot and can burn skin. Built-up pressure may cause an explosive release of coolant when the radiator cap is removed:

- Shut off engine and allow to cool.
- Do not remove the cap unless the radiator and the engine are cool enough to touch with bare hands.
- To release all pressure, slowly loosen the cap to the first stop. Then remove the cap.



MXT020129—UN—05MAY17

2. Slowly open radiator cap (A) to the first stop to release all pressure.
3. Remove cap after all pressure is released.

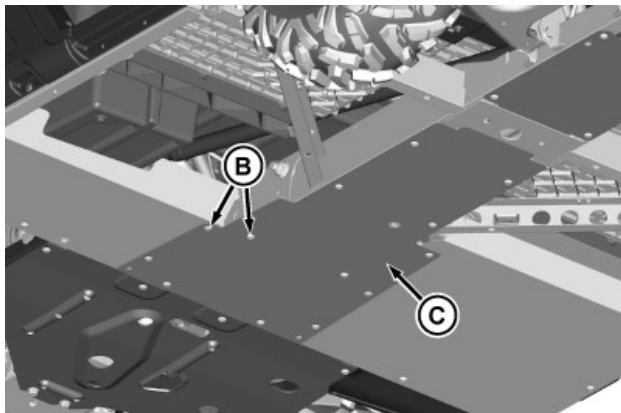

MXT020790—UN—31AUG17

4. Remove 13 screws (B) and closeout panel (C) from machine.

5. Place a coolant drain pan under area where closeout panel was removed.

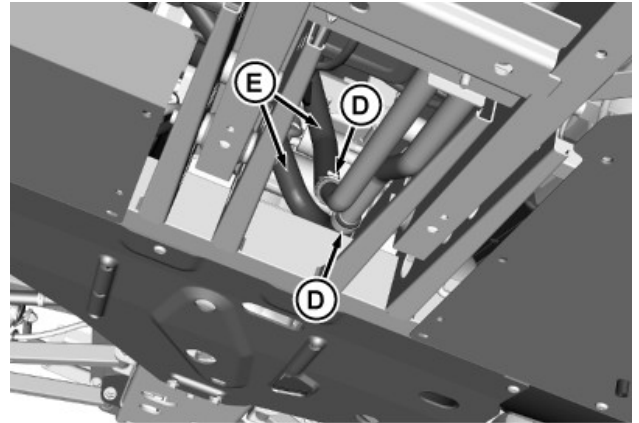

MXT020791—UN—31AUG17

View from under right (passenger) side.

6. Loosen hose clamps (D), and disconnect radiator hoses (E) from intermediate tubes.
7. Route radiator hoses over the drain pan and allow coolant to drain into the drain pan.

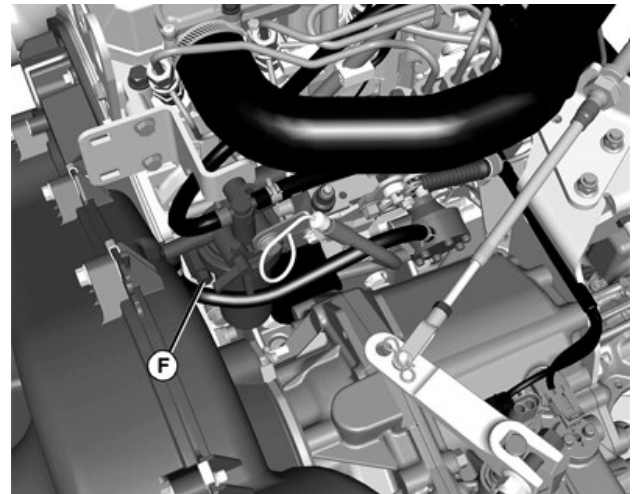

MXAL44570—UN—28MAR13

8. Loosen engine block drain screw (F).
9. Raise the front of the machine to ensure complete drainage of coolant.
10. After all coolant has drained, lower front of machine, connect radiator hoses (E), tighten the hose clamps (D), and tighten the drain screw (F).

NOTE: Models without HVAC have the recovery tank mounted on the right side of the radiator. Models with HVAC have the recovery tank mounted on the left side of the radiator.

Service Engine

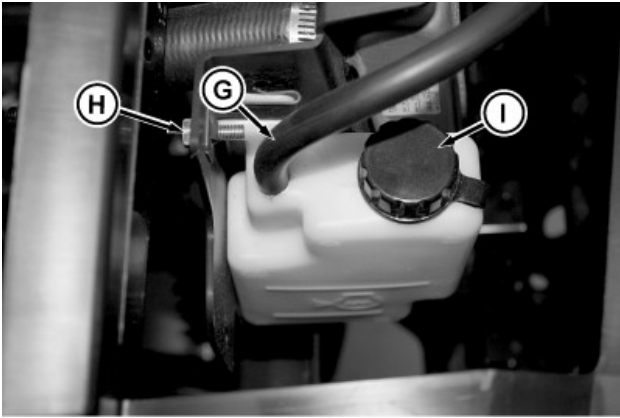

MXT020792—UN—31AUG17

11. Remove overflow hose (G) from recovery tank.
12. Remove the screw (H) and lift recovery tank out of machine.
13. Remove cap (I) and empty recovery tank into drain pan.
14. Check condition of all hoses. Replace as needed. Check all hose clamps and tighten as needed.
15. Install recovery tank in machine and secure with screw (H).

IMPORTANT: Avoid damage! Install overflow hose properly to ensure proper function of the cooling system. Position hose slightly above bottom of reservoir. Do not allow the hose to contact bottom of reservoir or bend upwards out of the coolant.

16. Install overflow hose (G) and cap (I).
17. Install closeout panel with 13 screws.
18. Fill and bleed cooling system.

Draining Coolant from Heater Core (Machines with HVAC)

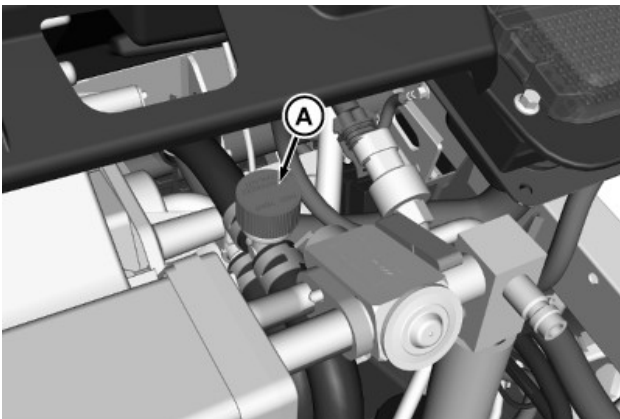

MXT020793—UN—31AUG17

1. Remove cap (A) on the bleed/fill fitting.
2. Place a coolant drain pan under the lower radiator hose on the left side of the machine.

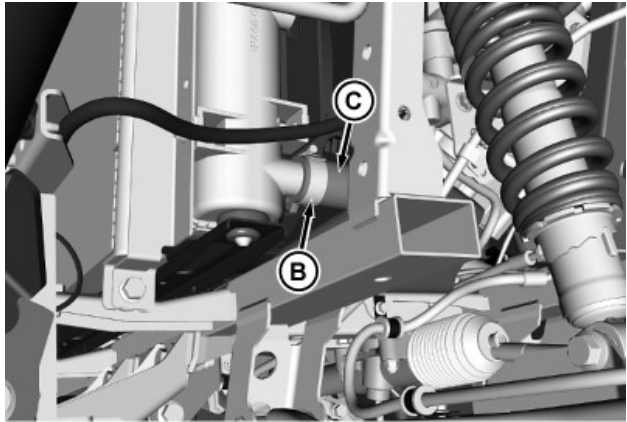

MXT020142—UN—09MAY17

3. Loosen hose clamp (B) and disconnect the lower radiator hose (C).
4. Route radiator hose over the drain pan and allow coolant to drain into the pan.
5. Raise the right side of the machine to ensure complete drainage of coolant.
6. After all coolant has drained, lower right side of the machine.
7. Connect lower radiator hose (C) and tighten the clamp (B).
8. Install cap on the bleed/fill fitting.

Filling and Bleeding Cooling System

IMPORTANT: Avoid damage! Using incorrect coolant mixture can damage the radiator:

- Do not operate engine without coolant or with plain water.
- Do not exceed a 50% antifreeze mixture for the coolant.
- Use antifreeze approved for use in aluminum engines.
- Do not pour coolant or water into radiator when engine is hot.
- Do not add Stop Leak or other additives.

NOTE: John Deere Cool-Gard™ coolant is recommended when adding coolant to the cooling system. Follow the directions on the container for the correct mixture ratio.

IMPORTANT: Avoid damage! Bleed screw uses a special aluminum seal washer. Do not lose or substitute with any other type of washer.

NOTE: Engine block bleed screw may be black in color.

Cool-Gard is a trademark of Deere & Company

Service Engine

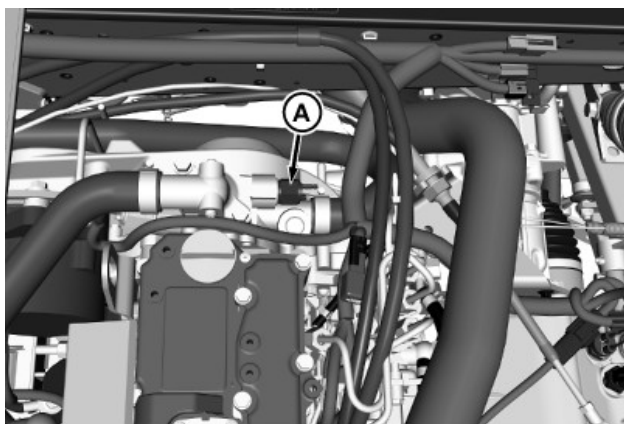

MXT020794—UN—31AUG17

1. Remove engine coolant switch (A) from manifold bleed port.
2. Remove radiator cap and add recommended coolant mixture to radiator until coolant runs out of bleed port.
3. Install and tighten coolant switch.
4. Add additional coolant mixture to radiator until coolant runs out of overflow port and into the recovery tank.
5. Install radiator cap.

IMPORTANT: Avoid damage! Position hose slightly above bottom of recovery tank. Do not allow hose to contact bottom of recovery tank or bend upwards out of the coolant.

6. Remove recovery tank cap and add coolant mixture to recovery tank until it is approximately half full.
7. Install recovery tank cap.

IMPORTANT: Avoid damage! If coolant temperature indicator comes on while engine is running, stop engine and add more coolant mixture to radiator.

8. Start and run engine at medium speed until upper and lower radiator hoses have become warm (10 - 15 minutes), indicating thermostat has opened and coolant is circulating.
9. Allow engine to cool.
10. Loosen bleed screw and allow air to bubble out until air bubbles are no longer visible at bleed port. Tighten bleed screw completely.
11. Remove radiator cap and add recommended coolant mixture to radiator until coolant runs out of overflow port and into the recovery tank.
12. Install radiator cap.
13. **On models equipped with HVAC:**
 - a. Raise the left front of the machine.

- b. Remove cap from the filler port near the heater core.
 - c. Add recommended coolant mixture until coolant appears at the base of the filler neck.
 - d. Install cap on the filler port.
 - e. Lower the machine.
14. Run engine until cooling fan starts, indicating the engine and coolant has reached operating temperature.
 15. Stop engine and remove key.
 16. Allow engine to cool and suction back any excess coolant from overflow recovery tank. Fill recovery tank as needed to lower line.

Flushing Cooling System

1. Drain cooling system.
2. Prepare a cooling system flushing solution using clean water and John Deere Cooling System Cleaner, John Deere Cooling System Quick Flush, or an equivalent.
3. Fill radiator completely with flushing solution. Install and tighten radiator cap.
4. Start and run engine until it reaches operating temperature.
5. Stop engine.

⚠ CAUTION: Avoid injury! The radiator is hot and can burn skin. Built-up pressure may cause an explosive release of coolant when the radiator cap is removed:

- Shut off engine and allow to cool.
 - Do not remove the cap unless the radiator and the engine are cool enough to touch with bare hands.
 - To release all pressure, slowly loosen the cap to the first stop. Then remove the cap.
6. Turn radiator cap slowly to the stop to release system pressure. Remove radiator cap.
 7. Drain cooling system immediately into a container before rust and dirt settle:
 - Disconnect radiator hoses from engine.
 - Loosen engine block drain screws.
 8. After all solution has drained, connect radiator hoses and tighten engine block drain screws.
 9. Remove and clean recovery tank.
 10. Install the recovery tank.
 11. Fill cooling system with recommended coolant mixture.

MX10673,000005B-19-31AUG17

Service Engine

Recommended Engine Coolant

IMPORTANT: Avoid damage! Using incorrect coolant mixture overheats and damages the radiator and engine:

- Do not operate engine with plain water.
- Do not exceed a 50% mixture of coolant and water.
- Aluminum engine blocks and radiators require approved ethylene glycol-based coolant.

The engine cooling system is filled to provide year-round protection against corrosion and cylinder liner pitting. Winter freeze protection is to -37 degrees C (-34 degrees F). If protection at lower temperatures is required, consult your John Deere dealer for recommendations.

The following coolants are preferred:

- John Deere Cool-Gard™ II Premix
- John Deere Cool-Gard™ Premix
- John Deere Cool-Gard™ PG Premix

John Deere Cool-Gard™ II Premix and John Deere Cool-Gard™ Premix are available in a concentration of 50% propylene glycol.

John Deere Cool-Gard™ PG Premix is available in a concentration of 55% propylene glycol.

Additional recommended coolants:

- John Deere Cool-Gard™ II Concentrate in a 40% to 60% mixture of concentrate with water.
- John Deere Cool-Gard™ Concentrate in a 40% to 60% mixture of concentrate with water.

If the recommended coolants are unavailable, use an ethylene glycol or propylene glycol base coolant that meets the following specification:

- ASTM D3306 prediluted (50%) coolant.
- ASTM D3306 coolant concentrates in a 40% to 60% mixture of concentrate with water.

Check container label before using to be sure that it has the appropriate specifications for your machine. Use coolant with conditioner or add conditioner to coolant before using.

Water Quality

- Water quality is important to the performance of the cooling system. Distilled, deionized, or demineralized water is recommended with ethylene glycol base engine coolant concentrate.

MX00654,0000029-19-25MAR15

Checking Radiator Hoses and Clamps

1. Park the vehicle safely. (See Parking Safely in the SAFETY section.)
2. Raise cargo box.
3. Open hood.
4. Remove the under hood storage tub, if equipped.

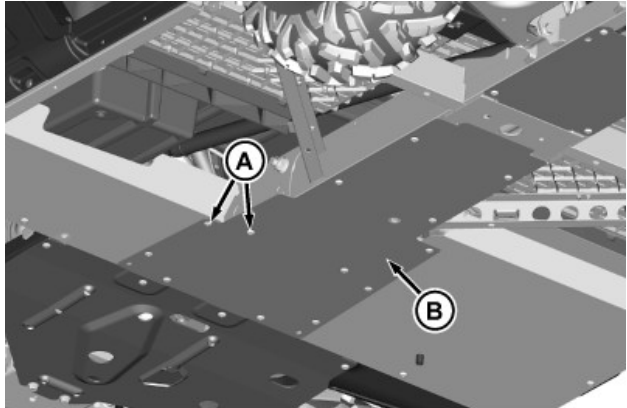

MXT019807—UN—17JAN17
Viewed from under right (passenger) side.

5. Remove 13 screws (A) and closeout panel (B) from machine.

NOTE: Visually inspect hoses for cracks and wear. Squeeze hoses to check for deterioration. Hoses should not be hard and brittle, nor soft or swollen.

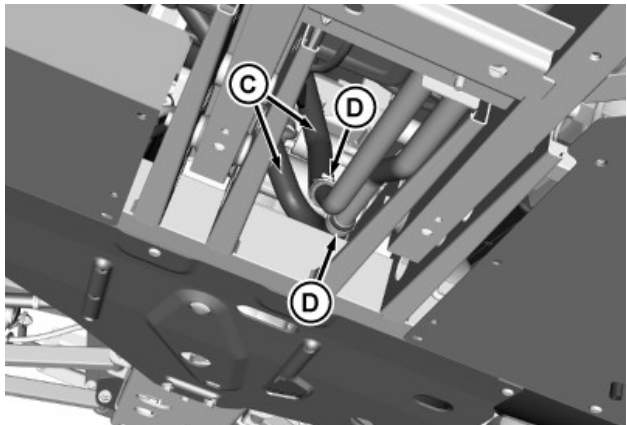

MXT019808—UN—17JAN17

Service Engine

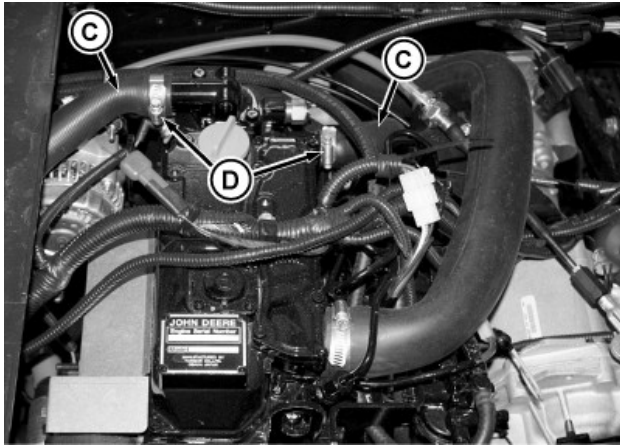

MXT019809—UN—17JAN17

6. Check radiator hoses (C) between intermediate tubes and engine for damage or cracking. Replace if necessary.
7. Check hose clamps (D) and tighten or replace as needed.

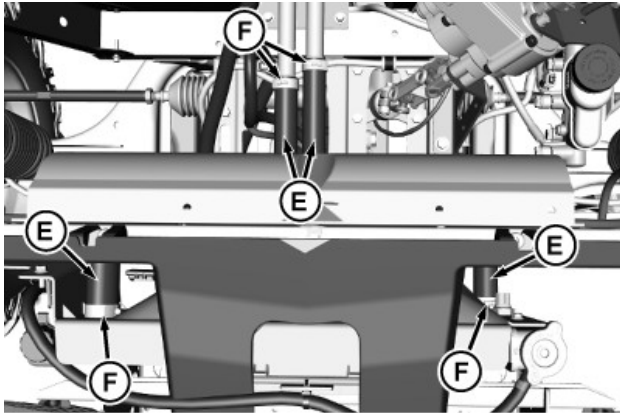

MXT019810—UN—17JAN17

8. Check radiator hoses (E) between intermediate tubes and radiator for damage or cracking. Replace if necessary.
9. Check hose clamps (F) and tighten or replace as needed.
10. Install the under hood storage tub, if equipped.
11. Install closeout panel with 13 screws.
12. Close hood.
13. Lower cargo box.

OUMX068,0001211-19-16JAN17

Inspecting Alternator Belt

1. Park the machine safely. (See Parking Safely in the SAFETY section.)
2. Raise and secure cargo box.

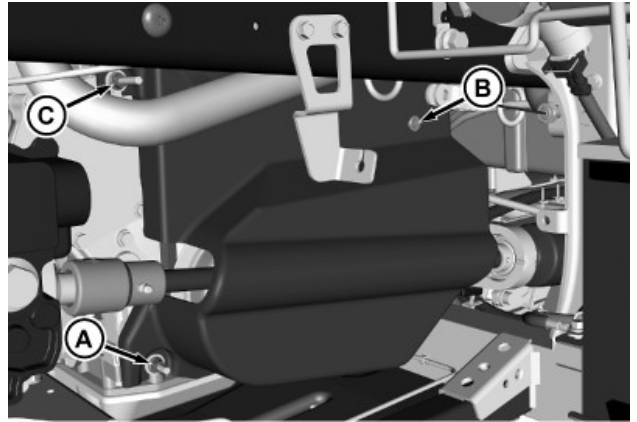

MXT020826—UN—09SEP17

Components hidden for a better view.

3. Loosen lower nut (A).
4. Remove push retainer (B).
5. Remove upper nut (C) and washer.

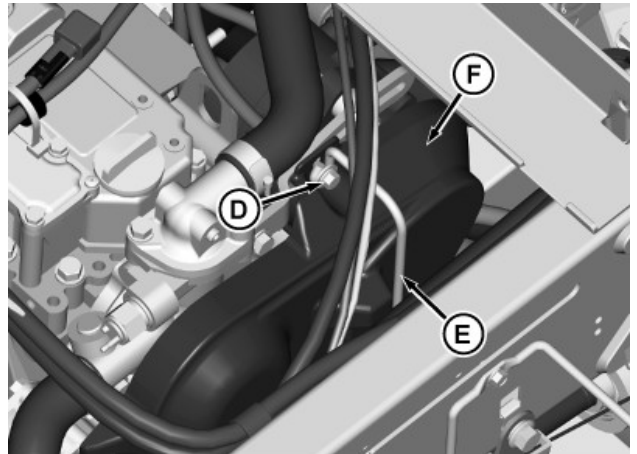

MXT020827—UN—09SEP17

6. Remove bolt (D) and washer, and remove hose hanger (E).
7. Remove belt cover (F).

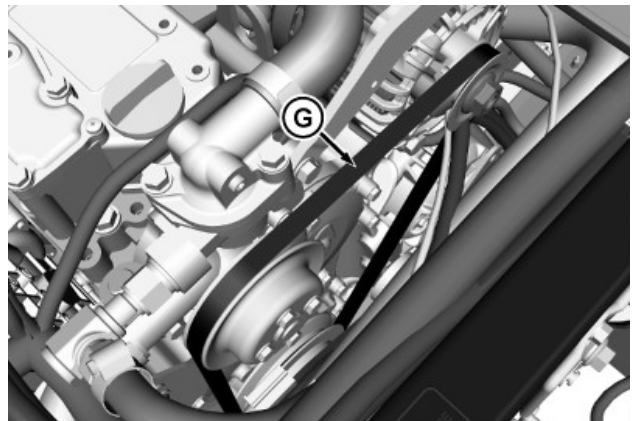

MXT020828—UN—09SEP17

8. Inspect belt (G) for wear or damage. Replace if worn

Service Engine

or damaged. (See your John Deere dealer for replacement.)

OUMX068,0001374-19-09SEP17

Inspecting HVAC Belt

1. Park the machine safely. (See Parking Safely in the SAFETY section.)
2. Raise and secure cargo box.

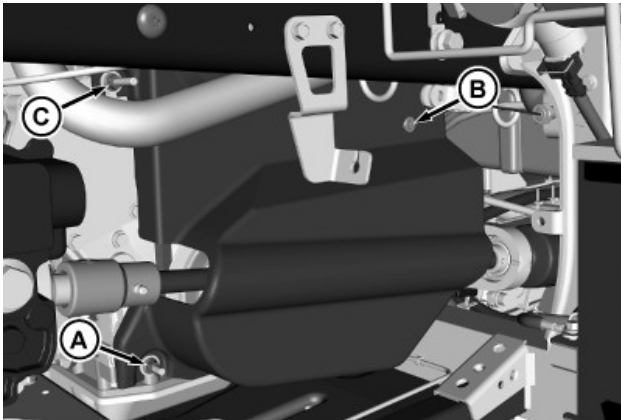

MXT020826—UN—09SEP17

Components hidden for a better view.

3. Loosen lower nut (A).
4. Remove push retainer (B).
5. Remove upper nut (C) and washer.

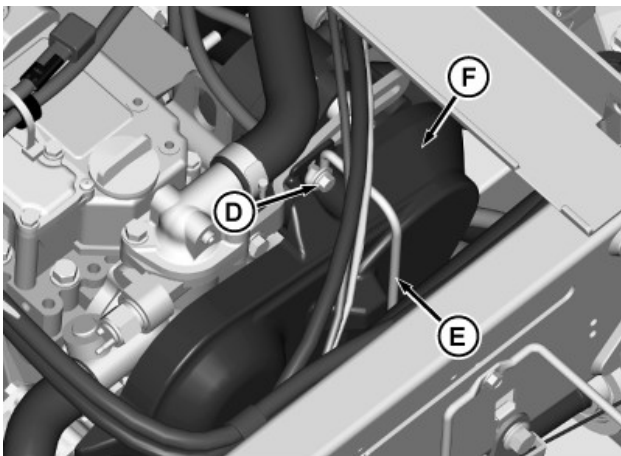

MXT020827—UN—09SEP17

6. Remove bolt (D) and washer, and remove hose hanger (E).
7. Remove belt cover (F).

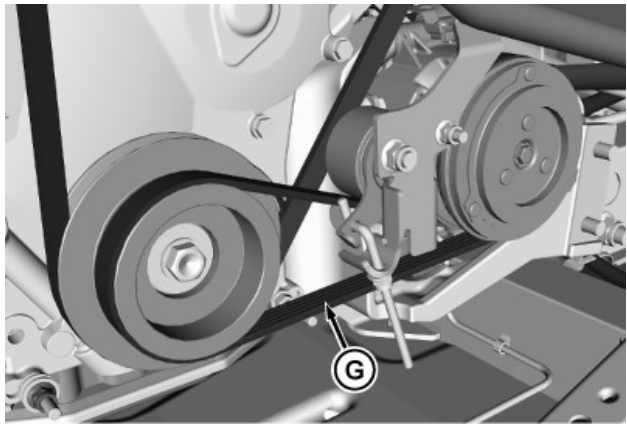

MXT020829—UN—09SEP17

8. Inspect belt (G) for wear or damage. Replace if worn or damaged. (See your John Deere dealer for replacement.)

OUMX068,0001375-19-09SEP17

Checking Spark Arrestor

⚠ CAUTION: Avoid injury! Touching hot surfaces can burn skin. The engine, components, and fluids are hot if the engine has been running. Allow the engine to cool before servicing or working near the engine and components.

1. Park the vehicle safely. (See Parking Safely in the SAFETY section.)
2. Allow machine to cool completely.

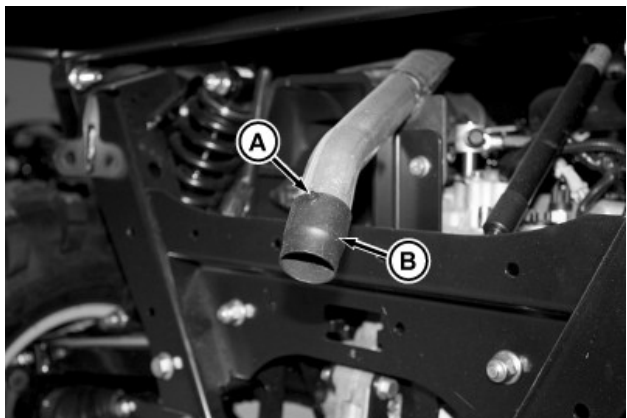

MXT019813—UN—17JAN17

3. Remove and retain screw (A) securing spark arrestor (B) to muffler exhaust pipe.
4. Remove the spark arrestor.

⚠ CAUTION: Avoid injury! Compressed air can cause debris to fly a long distance.

- Clear work area of bystanders.
- Wear eye protection when using compressed air for cleaning purposes.

Service Engine

- Reduce compressed air pressure to 210 kPa (30 psi).
5. Make sure that the deflector screen inside arrestor is not plugged or damaged:
 - If plugged, spray with carburetor/choke cleaner and blow dry with low pressure compressed air.
 - If damaged, replace the spark arrestor.
 6. Install the spark arrestor with original hardware.

OUMX068,0001213-19-17JAN17

Service Transmission

Transaxle Oil

Use the appropriate oil viscosity based on these air temperature ranges. Operating outside of these recommended oil air temperature ranges may cause premature hydrostatic transmission or hydraulic system failures.

IMPORTANT: Mixing of LOW VISCOSITY HY - GARD™ and HY - GARD™ oils is permitted. DO NOT mix any other oils in this transmission. DO NOT use engine oil or “Type F” (Red) Automatic Transmission Fluid in this transmission.

John Deere J20C HY-GARD™ transmission and hydraulic oil is recommended. John Deere J20D Low Viscosity HY-GARD™ transmission and hydraulic oil may be used, if within the specified temperature range.

Other oils may be used if above recommended John Deere oils are not available, provided they meet one of the following specifications:

- John Deere Standard JDM J20C;
- John Deere Standard JDM J20D.

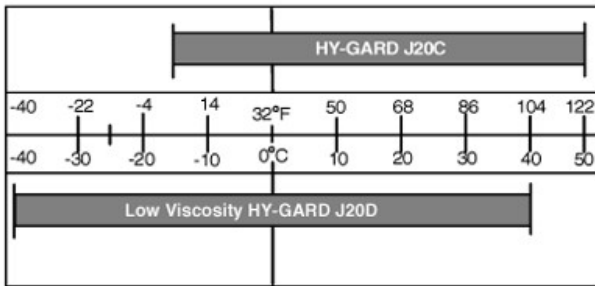

MXAL44246—UN—10APR13
MX00654,00000C5-19-24AUG13

4WD Front Differential Oil

Use the appropriate oil viscosity based on these air temperature ranges. Operating outside of these recommended oil air temperature ranges may cause premature hydrostatic transmission or hydraulic system failures.

IMPORTANT: Mixing of LOW VISCOSITY HY - GARD™ and HY - GARD™ oils is permitted. DO NOT mix any other oils in this transmission. DO NOT use engine oil or “Type F” (Red) Automatic Transmission Fluid in this transmission.

John Deere J20C Low Viscosity HY-GARD™ transmission and hydraulic oil is recommended.

Other oils may be used if above recommended John Deere oils are not available, provided they meet the following specifications:

- John Deere Standard JDM J20C.

MX00654,00000C6-19-24AUG13

Checking 4WD Front Differential Oil Level

1. Park machine safely. (See Parking Safely in the SAFETY section.)
2. Allow machine to cool down for at least 1 hour.

IMPORTANT: Avoid damage! Dirt and debris in the oil can damage the 4WD differential. Clean area around opening before removing plug.

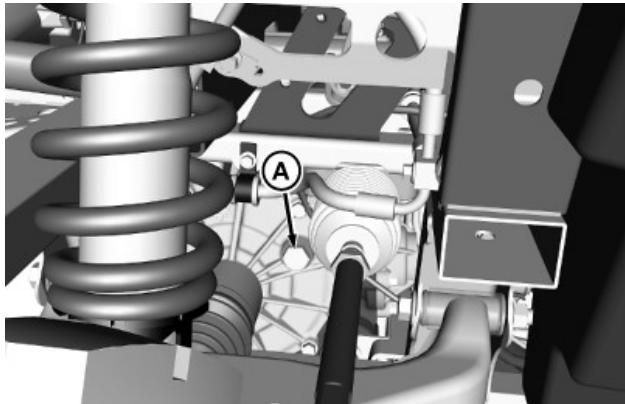

MXT019814—UN—17JAN17

Fill plug under left front side.

3. Remove the fill plug (A) on the left side of the 4WD front differential.
4. Oil must be level with the bottom of the fill port. If oil level is low:
 - a. Add oil through the fill port until level is correct.
 - b. Install and tighten the fill plug to specification.

Specification

Fill Plug—Torque. 11—40 N·m (8—30 lb·ft)

OUMX068,0001214-19-17JAN17

Changing 4WD Front Differential Oil

1. Operate machine to warm 4WD front differential oil.
2. Park machine safely. (See Parking Safely in the SAFETY section.)

IMPORTANT: Avoid damage! Dirt and debris in the oil can damage the 4WD differential. Clean area around opening before removing plug.

Service Transmission

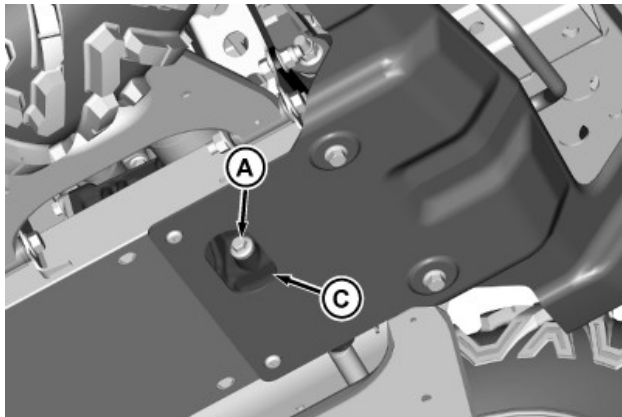

MXT019815—UN—17JAN17

Drain plug under right front side.

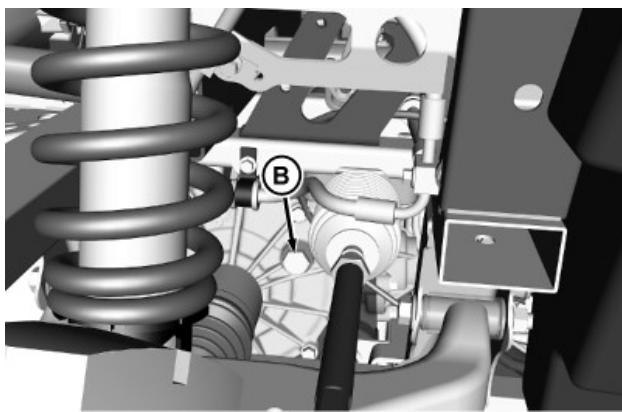

MXT019816—UN—17JAN17

Fill plug under left front side.

3. Position drain pan under the 4WD front differential drain plug (A) at bottom right of housing.
4. Remove the fill plug (B) on the left side of the 4WD front differential.
5. Remove 4WD front differential drain plug (A) and allow oil to drain through opening (C) in skid plate and into the drain pan.
6. Check washer on the drain plug. Replace if missing or in poor condition.
7. Install and tighten drain plug to specification after all oil has drained.

Specification

Drain Plug—Torque. 7—14 N·m (5—10 lb·ft)

8. Add oil until the level is even with the bottom of the fill port.
9. Install and tighten the fill plug to specification.

Specification

Fill Plug—Torque. 11—40 N·m (8—30 lb·ft)

10. Check 4WD front differential oil level again after the first several hours of operation.

OUMX068,0001215-19-17JAN17

Checking Transaxle Oil Level

IMPORTANT: Hot hydraulic oil will expand and show incorrect oil level. Check oil level:

- When oil is cold.
- With engine not running.

1. Park the vehicle safely. (See Parking Safely in the SAFETY section.)
2. Raise and secure cargo box.

IMPORTANT: Dirt and debris in oil may cause damage to the transaxle. Clean area around opening before removing dipstick.

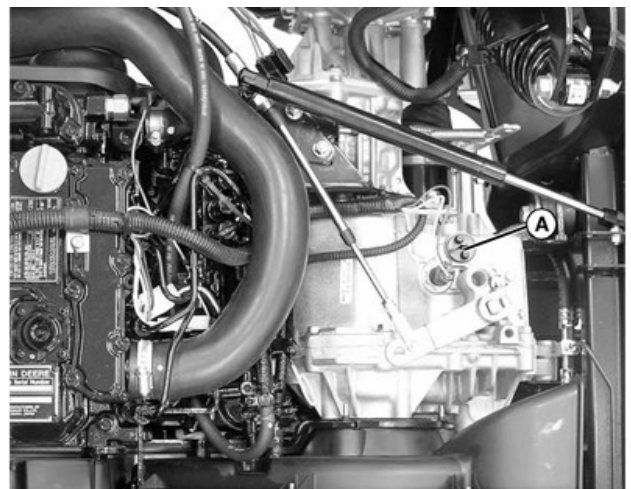

MXAL44586—UN—28MAR13

3. Remove dipstick (A) located on the top of the transaxle housing. Wipe dipstick clean.
4. Check oil level by setting dipstick on threads in transaxle case, then removing and checking oil level.
5. Add oil as needed through the dipstick fill hole.
6. Install and tighten dipstick.
7. Lower the cargo box.

MX00654,0000115-19-06SEP13

Changing Transaxle Oil

1. Park the vehicle safely. (See Parking Safely in the SAFETY section.)
2. Raise and secure cargo box.

IMPORTANT: Avoid damage! Dirt and debris in the oil can damage the transaxle. Clean area around opening before removing dipstick.

Service Transmission

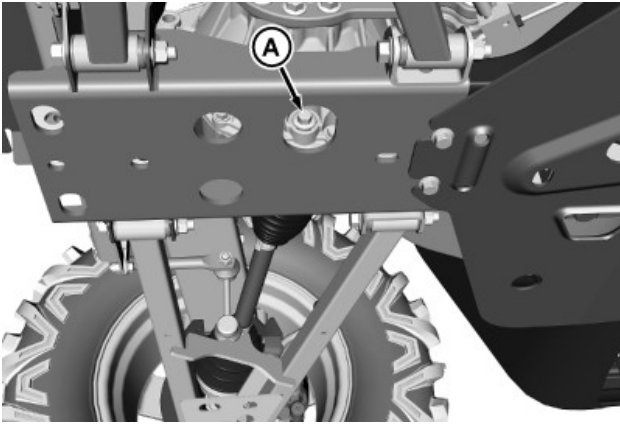

MXT019818—UN—17JAN17

3. Position drain pan under the transaxle drain plug (A).
4. Remove plug and drain oil.
5. Check washer on the drain plug. Replace if missing or in poor condition.
6. Install and tighten drain plug to specification.

Specification

Drain Plug—Torque. 44—54 N·m (32.5—40 lb·ft)

7. Remove dipstick on top of the transaxle housing. Wipe dipstick clean.
8. Add recommended fluid.

NOTE: Check oil level by setting dipstick on threads in transaxle case, then removing and checking oil level.

9. Wait for two minutes, then check oil level. Add oil if necessary.
10. Install dipstick and tighten.
11. Lower the cargo box.

OUMX068,0001217-19-17JAN17

Inspecting Driveline CV Boots

1. Park the vehicle safely. (See Parking Safely in the SAFETY section.)

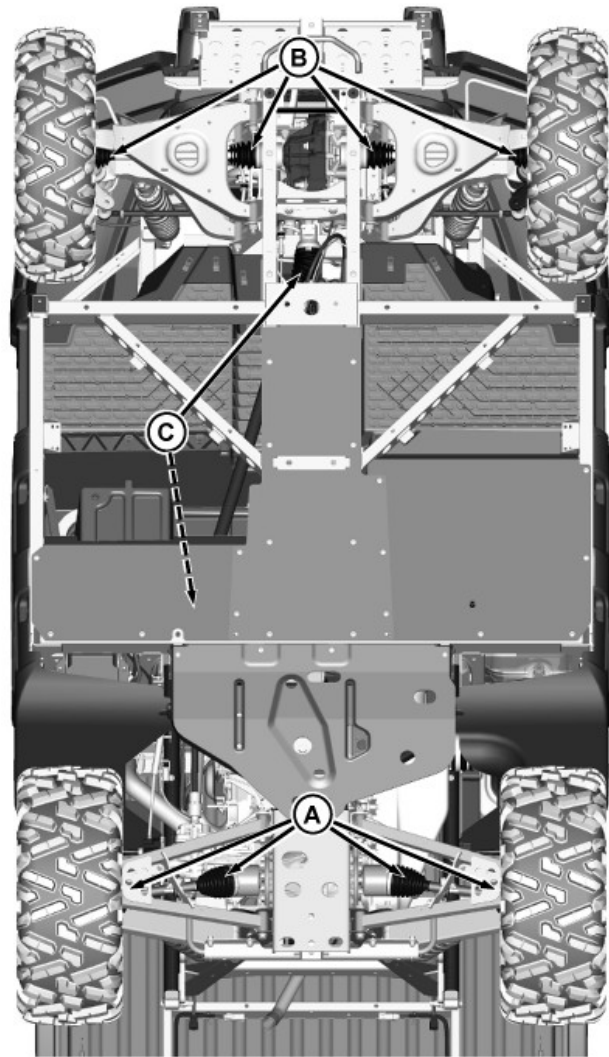

MXT019819—UN—15FEB17

Viewed from under the machine.

2. Inspect four rear CV boots (A) for tears or punctures.
3. Inspect four front CV boots (B) for tears or punctures.
4. Inspect front and rear driveshaft boots (C) for tears or punctures.
5. If replacement of a boot is necessary, see your John Deere dealer.

OUMX068,0001218-19-17JAN17

Servicing Drive Belt

Inspecting Drive Belt

⚠ CAUTION: Avoid injury! Rotating parts can catch fingers, loose clothing, or long hair. Wait for engine and all moving parts to stop before leaving operator's station to adjust or service machine.

Service Transmission

1. Park the machine safely. (See Parking Safely in the SAFETY section.)
2. Raise and secure the cargo box.

NOTE: Drive belt can be inspected through enclosure exhaust port (A) without removing clutch enclosure cover.

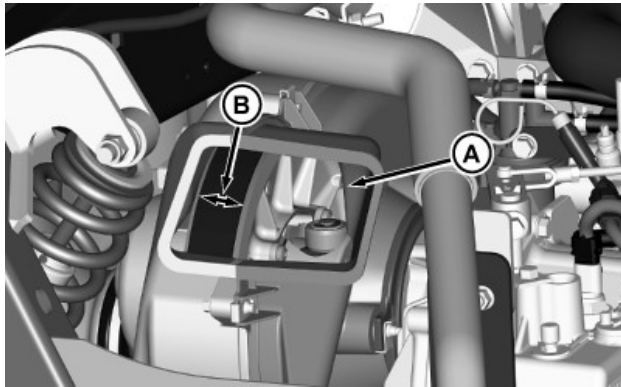

MXT020795—UN—31AUG17

3. Measure the top surface of the belt width at (B). Replace belt if dimension is less than minimum specification.

Specification

Drive Belt Top Surface
(min.)—Width. 29 mm (1.1 in.)

4. Check for debris inside enclosure exhaust port and clean if needed.

Removing Drive Belt

CAUTION: Avoid injury! Rotating parts can catch fingers, loose clothing, or long hair. Wait for engine and all moving parts to stop before leaving operator's station to adjust or service machine.

1. Park the machine safely. (See Parking Safely in the SAFETY section.)
2. Raise and secure the cargo box.

CAUTION: Avoid injury! The machine can fall or slip from an unsafe lifting device or supports.

- Use a safe lifting device rated for the load to be lifted.
- Lower machine onto jack stands or other stable supports and block wheels before servicing.

3. Lift the machine and secure so tires are off the ground and the suspension hangs freely.

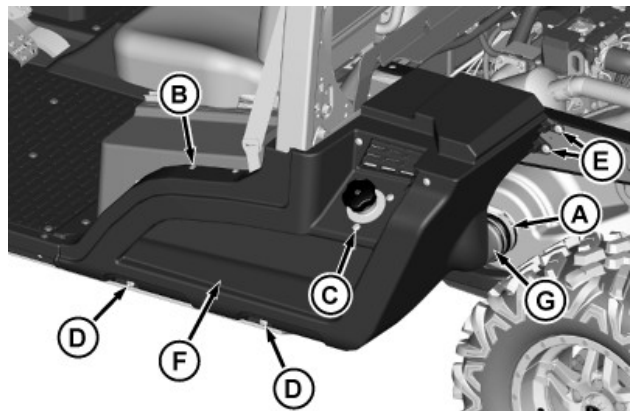

MXT020796—UN—31AUG17

4. Loosen clamp (A) on intake hose.
5. Remove five push retainers (B).
6. Remove three screws (C) around filler neck.
7. Remove two lower screws (D) and two frame screws (E).
8. Remove side panel (F) and intake hose (G) as one assembly.

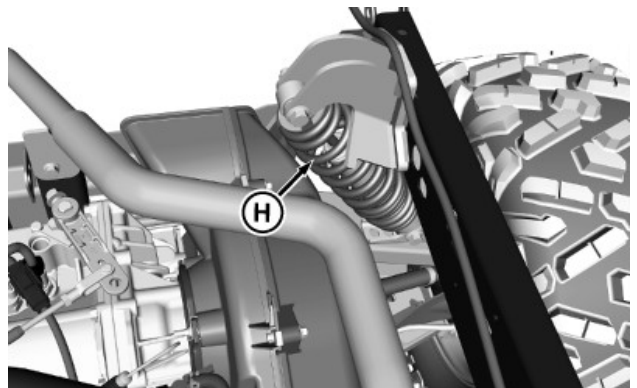

MXT020798—UN—31AUG17

9. Remove left rear shock (H).

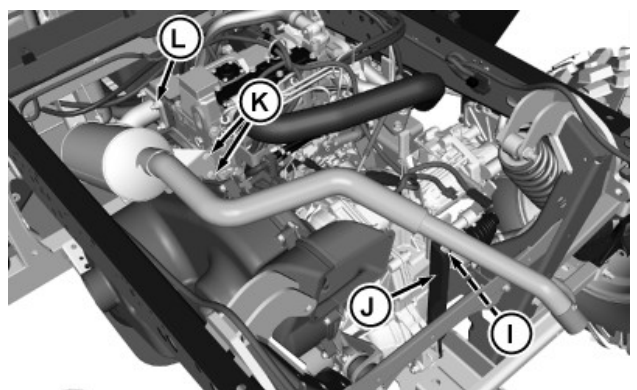

MXT020797—UN—31AUG17

10. Remove bolt and nut (I) securing exhaust pipe to bracket (J).
11. Remove two bolts and nuts (K).
12. Remove four nuts (L) and remove muffer and exhaust pipe.

Service Transmission

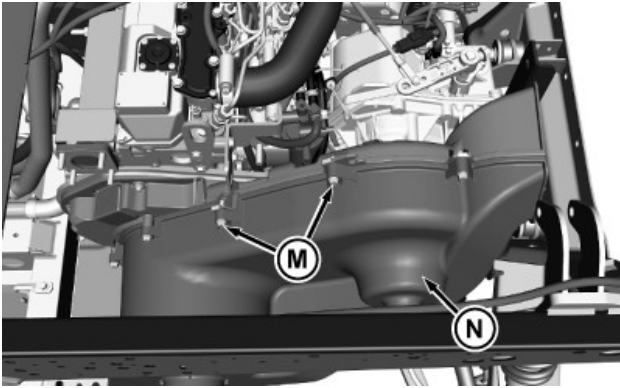

MXT020799—UN—31AUG17

13. Remove eleven bolts around (M) clutch enclosure cover (N). Remove clutch enclosure cover.

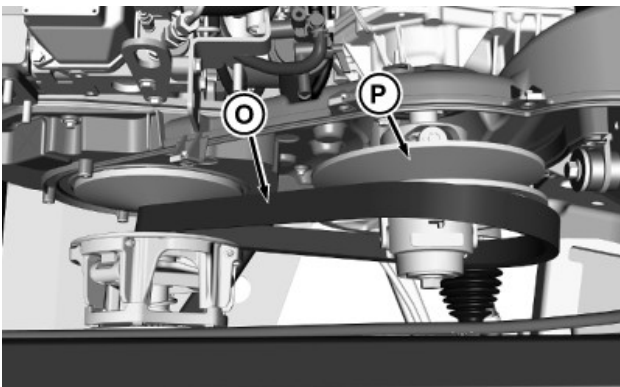

MXT020800—UN—31AUG17

14. Lift up on drive belt (O) to make slack.
15. Start drive belt over edge of driven clutch (P) and turn clockwise until drive belt is removed.

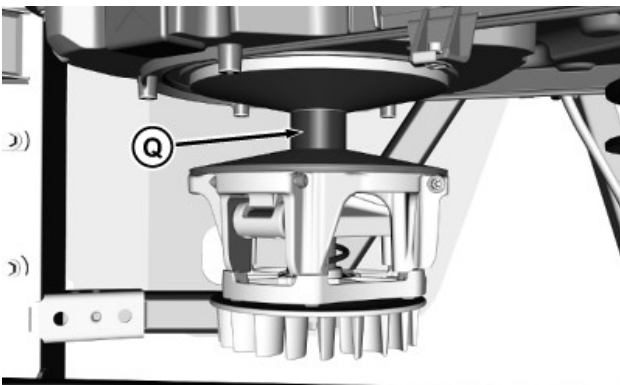

MXT020801—UN—31AUG17

16. Spin idler sleeve bearing (Q). Confirm bearing rotates smoothly. If not, contact your John Deere dealer for possible bearing replacement.

Replacing Drive Belt

NOTE: Make sure arrows on drive belt face towards the front of machine.

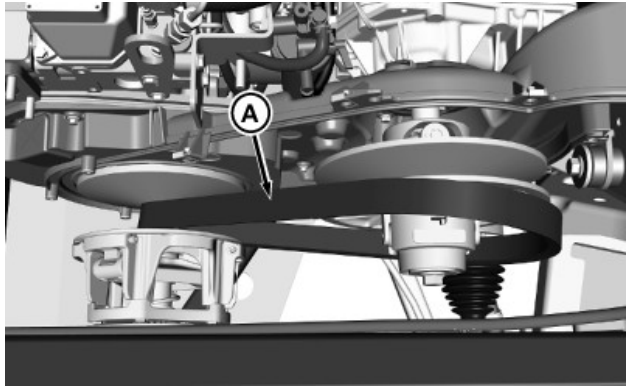

MXT020802—UN—31AUG17

1. Loop belt (A) over drive clutch and around driven clutch, starting at bottom and slide belt into driven clutch while turning.

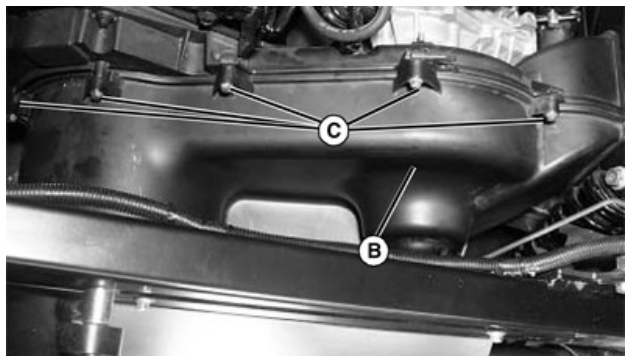

MXAL44596—UN—28MAR13

2. Install clutch enclosure cover (B) and eleven bolts (C).

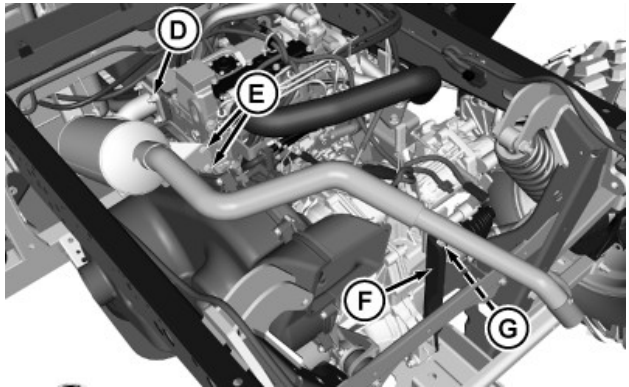

MXT020804—UN—31AUG17

3. Loosely install muffler to exhaust manifold with four nuts (D).
4. Loosely install two bolts and nuts (E) securing muffler to bracket.
5. Loosely install exhaust pipe to bracket (F) with bolt and nut (G).
6. Tighten all bolts and nuts.

Service Transmission

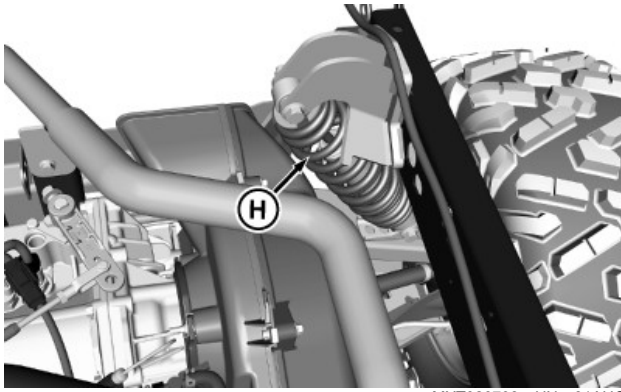

MXT020798—UN—31AUG17

7. Install left rear shock (H).

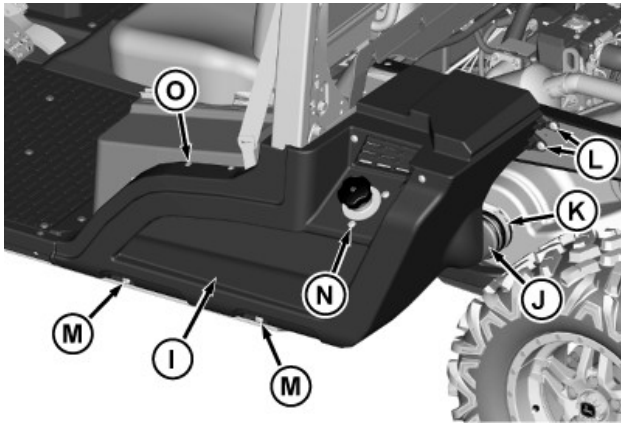

MXT020805—UN—31AUG17

8. Install side panel (I) over filler neck and onto machine.
9. Connect intake hose (J) to clutch enclosure and tighten clamp (K).
10. Loosely install two frame screws (L) and two lower screws (M).
11. Loosely install three screws (N) around filler neck.
12. Install five push retainers (O).
13. Tighten the seven screws.

MX10673,000005C-19-31AUG17

Checking Driven Clutch Rollers

1. Park the vehicle safely. (See Parking Safely in the SAFETY section.)
2. Raise and secure cargo box.

NOTE: Clutch rollers can be inspected through enclosure exhaust port (B) without removing clutch enclosure covers.

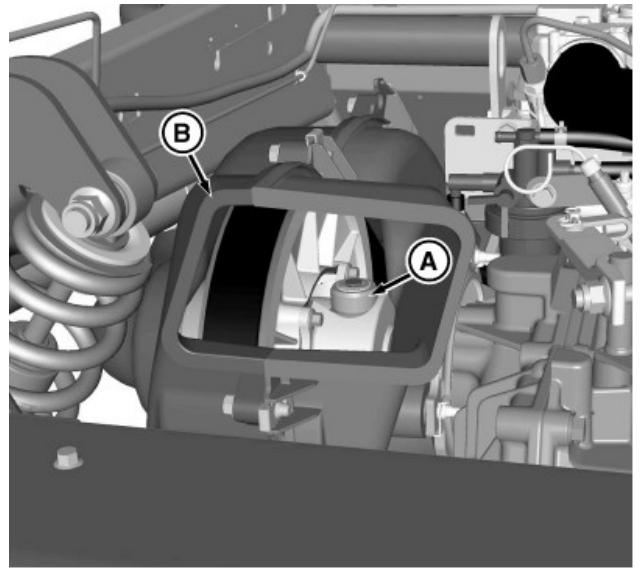

MXT008468—UN—07SEP13

3. Move machine slightly forward or backward so clutch roller (A) can be seen through the exhaust port (B).
4. Check worn clutch rollers (A):
 - a. There should not be any excessive wear, play, or metal-to metal contact.
 - b. If replacement is necessary, see your John Deere dealer.
5. Lower the cargo box.

MX00654,0000123-19-18SEP14

Cleaning Primary Drive Clutch and Enclosure

IMPORTANT: Avoid damage! Never lubricate any part of the primary drive clutch.

1. Park the machine safely. (See Parking Safely in the SAFETY section.)
2. Raise and secure the cargo box.

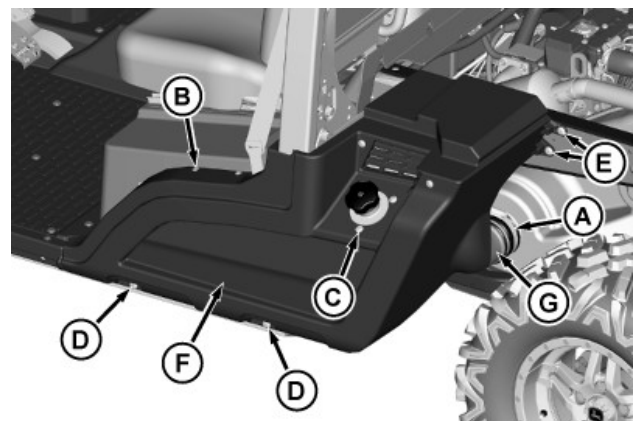

MXT020796—UN—31AUG17

3. Loosen clamp (A) on intake hose.

Service Transmission

4. Remove five push retainers (B).
5. Remove three screws (C) around filler neck.
6. Remove two lower screws (D) and two frame screws (E).
7. Remove side panel (F) and intake hose (G) as one assembly.

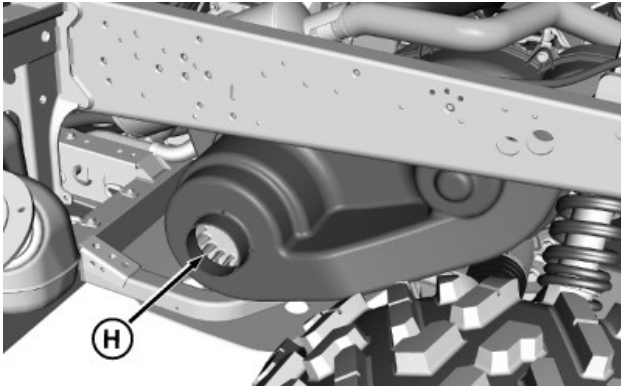

MXT020806—UN—31AUG17

8. Through access hole (H), use compressed air and blow dust and debris out of clutch fan area.

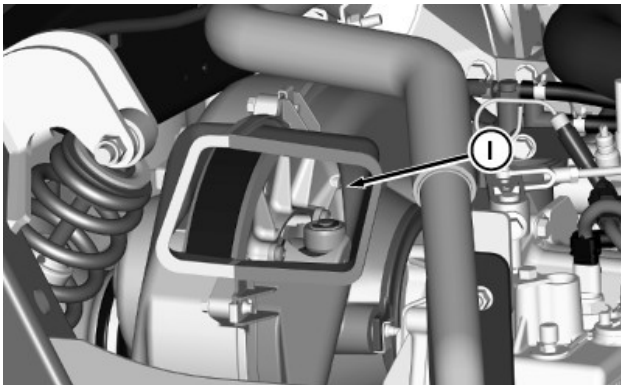

MXT020807—UN—31AUG17

9. Check exhaust port (I) for debris.
10. If debris is found inside exhaust port, remove the following:

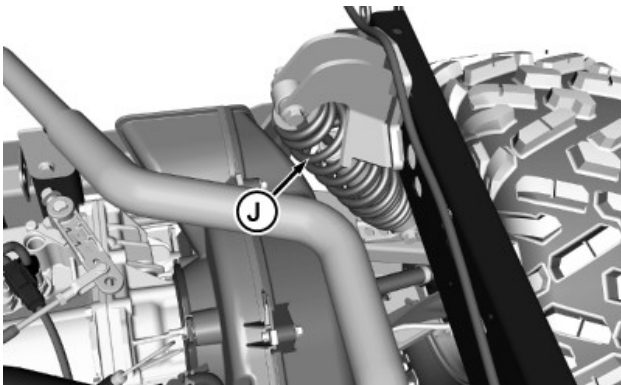

MXT020808—UN—31AUG17

- a. Remove left rear shock (J).

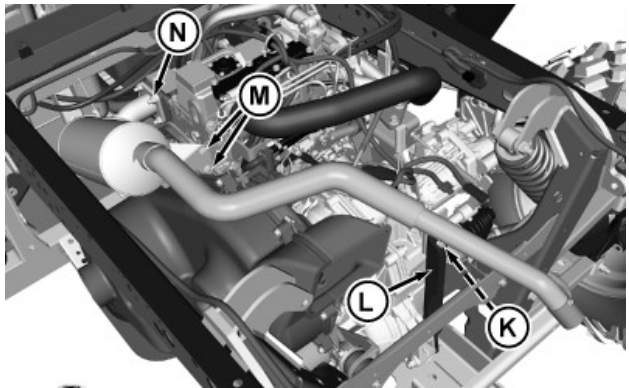

MXT020809—UN—31AUG17

- b. Remove bolt and nut (K) securing exhaust pipe to bracket (L).
- c. Remove two bolts and nuts (M).
- d. Remove four nuts (N) and remove muffler and exhaust pipe.

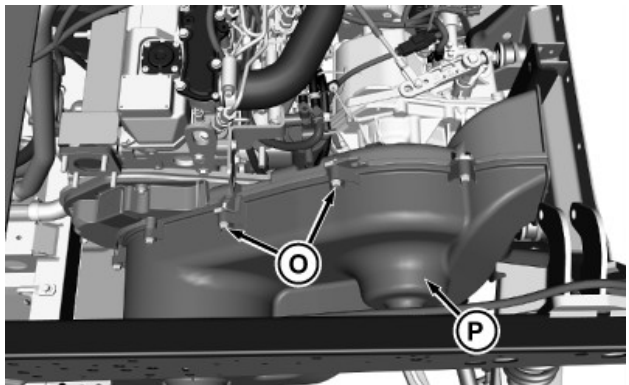

MXT020810—UN—31AUG17

- e. Remove eleven bolts around (O) clutch enclosure cover (P). Remove clutch enclosure cover.

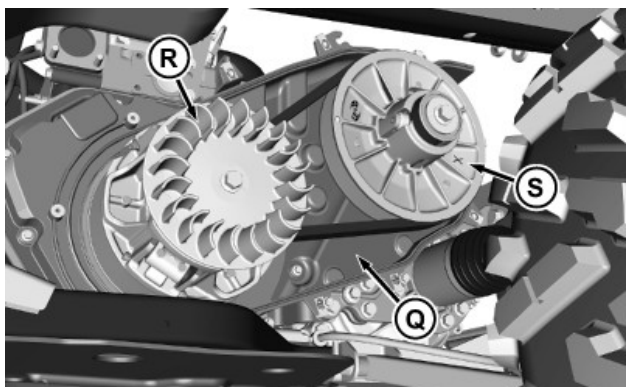

MXT020811—UN—31AUG17

11. Clean inside clutch enclosure base (Q), and around drive (R) and driven clutch (S) assemblies.
12. Install enclosure cover.
13. Install muffler and exhaust pipe.
14. Install shock.
15. Install air intake hose and side panel.

Service Transmission

16. Lower the cargo box.

MX10673,000005D-19-31AUG17

Service Steering & Brakes

Brake Fluid

The following heavy duty brake fluid is **PREFERRED** for all drum and disc brakes:

- Brake Fluid - DOT4
Other brake fluids may be used if they provide the following:
 - Conforms to Motor Vehicle Safety Standard No. 116.
 - Minimum wet boiling point 155°C (311°F).
 - Minimum dry boiling point 230°C (446°F) to prevent vapor lock.

MX00654,00000C7-19-24AUG13

Checking Brake Fluid Level

IMPORTANT: Avoid damage! Avoid contamination of the brake fluid. Clean the area around the filler cap before removing. Do not open the reservoir cap unless necessary.

Use extreme care when filling the reservoir. Fluid spilled on painted surfaces causes damage.

Use only brake fluid from a sealed container.

1. Park machine safely. (See Parking Safely in the SAFETY section.)
2. Open hood.

NOTE: Do not overfill the reservoir. Overfilling causes leakage.

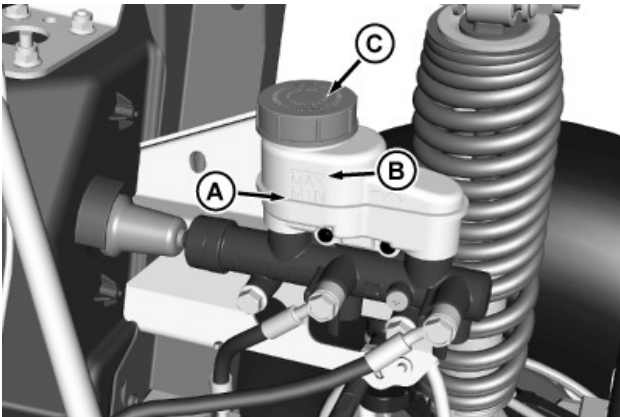

MXT019887—UN—22FEB17

3. Visually check brake fluid reservoir. Brake fluid level must be between "MIN" (A) and "MAX" (B) marks. If fluid is low:

- Carefully clean area around the reservoir cap (C).
- Remove reservoir cap and add fluid to the "MAX" mark.

4. Install reservoir cap.

5. Close hood.

OUMX068,0001240-19-22FEB17

Checking Brake Pads

1. Park machine safely. (See Parking Safely in the SAFETY section.)

⚠ CAUTION: Avoid injury! The machine can fall or slip from an unsafe lifting device or supports.

- Use a safe lifting device rated for the load to be lifted.
- Lower machine onto jack stands or other stable supports and block wheels before servicing.

IMPORTANT: Avoid damage! Place jack stands under frame, not under transmission or engine, when raising or supporting machine

2. Raise machine with a safe lifting device and lower machine onto jack stands or other stable supports. Block wheels remaining on the ground to prevent machine movement
3. If present, remove center cap before removing wheel.

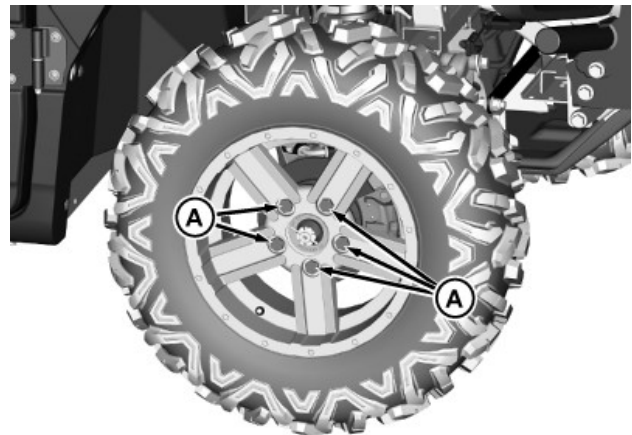

MXT019891—UN—22FEB17

4. Remove the wheel bolts (A).
5. Remove the wheel assembly.

Service Steering & Brakes

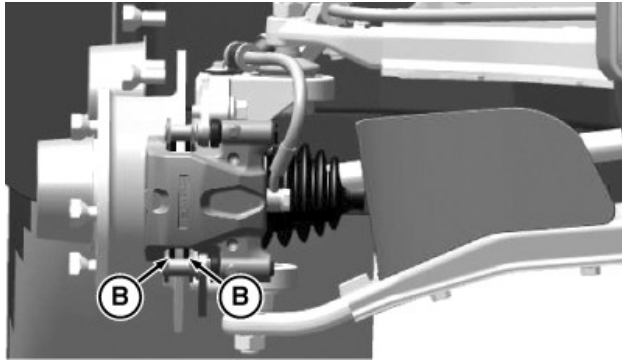

MXT023345—UN—01AUG18
Right front brake pads are shown

- Inspect brake pads (B) for wear or damage. Check each pads thickness. Material must not be less than minimum specification. If below specification or brake pad is damaged, see your John Deere dealer for replacement service.

Specification

Pad Friction
Material—Thickness. 1 mm (3/64 in)

- Install wheel assembly with the valve stem to the outside.
- Tighten wheel bolts evenly in alternating sequence until snug.
- Repeat procedure for remaining three wheels.
- Lower machine to the ground.
- Tighten wheel bolts to:
 - Standard wheel assembly: 108 N·m (80 lb·ft)
 - Sport wheel assembly: 142 N·m (105 lb·ft)

OUMX068,0001241-19-01AUG18

Checking Park Brake Fluid

- Park machine safely on a level surface. (See “Park Machine Safely” in the SAFETY section.)
- Raise and secure cargo box.

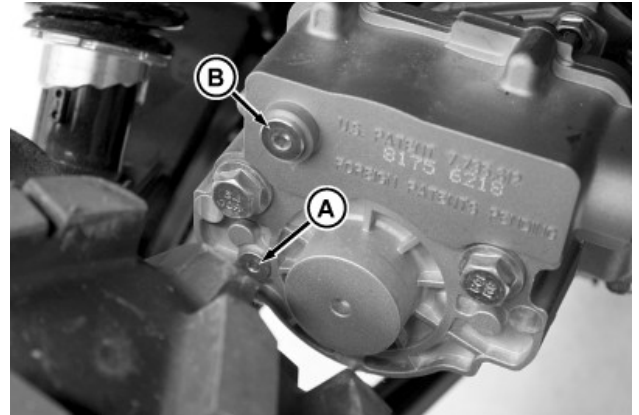

MXT019889—UN—22FEB17
Viewed from right rear side of machine.

- Remove hex socket plug (A) and check lubricant level in the park brake housing. Fluid level must be at bottom of plug opening.
- If not at the proper level, remove hex socket plug (B). Add recommended fluid until at bottom of plug (A) opening. Install plug (A).
- Install plug (B).

OUMX068,0001242-19-22FEB17

Checking Brake Lines

- Park machine safely. (See Parking Safely in the SAFETY section.)
- Protect any painted surfaces from expelled brake fluid and wipe any areas of excess brake fluid.
- Open hood.

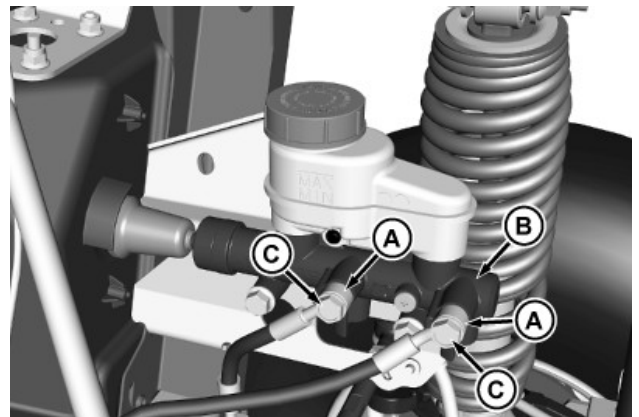

MXT019890—UN—22FEB17

- Check the brake line fittings (A) on the side of the master cylinder (B) for leaks.
- Tighten banjo bolts (C), as needed, to specification.

Specification

Banjo Bolts—Torque. 27 N·m (20 lb·ft)

- Rotate wheels for access to brake calipers.

Service Steering & Brakes

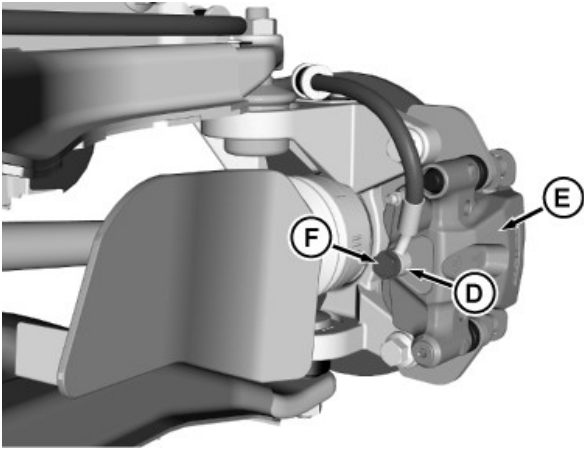

MXT019892—UN—22FEB17

Left front brake line shown.

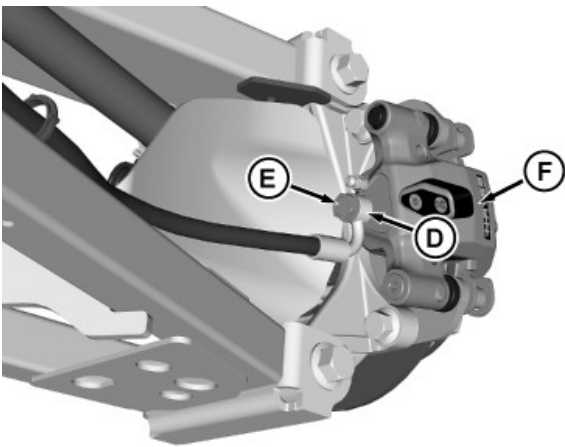

MXT019893—UN—22FEB17

Left rear brake line shown.

7. Check brake line fitting (D) on each brake caliper (E) for leaks. Tighten banjo bolt (F), as needed, to specification.

Specification

Banjo Bolt—Torque. 27 N·m (20 lb·ft)

8. Lower hood.
9. Start vehicle and press brake pedal. If leaks are still found, see your John Deere Dealer for service.

OUMX068,0001243-19-22FEB17

Adjusting Park Brake

For proper adjustment of the park brake system, see your John Deere Dealer.

JG81906,0000742-19-01APR13

Service Electrical

Electrical

WARNING: Battery posts, terminals and related accessories contain lead and lead components, chemicals known to the State of California to cause cancer and reproductive harm. **Wash hands after handling.**

MP47322,00F466E-19-15MAR13

Service the Battery Safely



MXAL41890—UN—18FEB13

CAUTION: Avoid injury! Battery electrolyte contains sulfuric acid. It is poisonous and can cause serious burns:

- Wear eye protection and gloves.
- Keep skin protected.
- If electrolyte is swallowed, get medical attention immediately.
- If electrolyte is splashed into eyes, flush immediately with water for 15-30 minutes and get medical attention.
- If electrolyte is splashed onto skin, flush immediately with water and get medical attention if necessary.

The battery produces a flammable and explosive gas. The battery may explode:

- Do not smoke near battery.
- Wear eye protection and gloves.
- Do not allow direct metal contact across battery posts.
- Remove negative cable first when disconnecting.
- Install negative cable last when connecting.

OOU1023,000009A-19-26MAY15

Checking the Battery (Sealed Batteries)

NOTE: Do not attempt to open, add fluid or service battery. Any attempt to do so will void warranty.

- Keep battery and terminals clean.
- Keep battery bolts tight.
- Keep small vent holes open.

IMPORTANT: This battery comes fully charged. If the machine is not used by the service expiration date indicated on the battery, charge the battery.

- Recharge, if necessary, at 6-10 amperes for 1 hour.

MP47322,00F4892-19-03APR13

Removing and Installing Battery

Removing

1. Park the machine safely. (See Parking Safely in the SAFETY section.)

NOTE: To aid in the removal of the side panel, remove air cleaner cover for clearance.

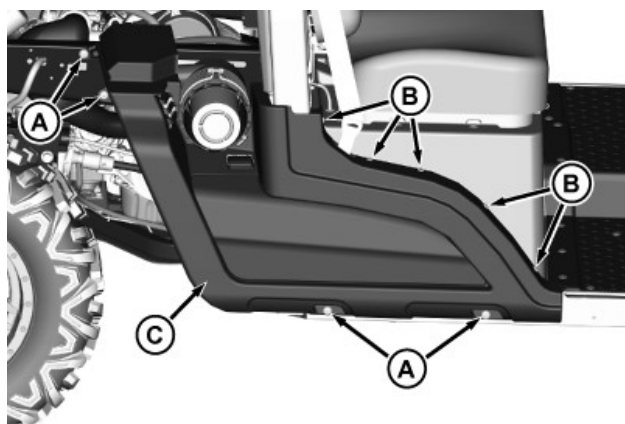

MXT020778—UN—29AUG17

2. Remove four screws (A) and five push retainers (B), and remove side panel (C).

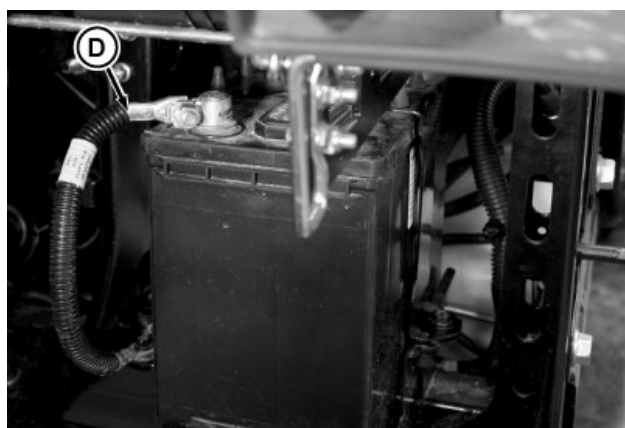

MXT020779—UN—29AUG17

3. Disconnect the negative (-) battery cable (D) from the battery.

Service Electrical

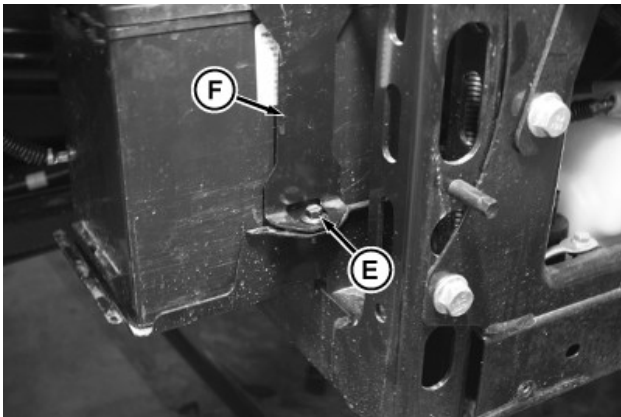

MXT020780—UN—29AUG17

4. Remove screw (E) on each side of the battery securing the mounting bracket (F).
5. Remove mounting bracket by lifting it over the negative (-) post.
6. Lift and slide the battery half way off the tray toward the rear of the machine.

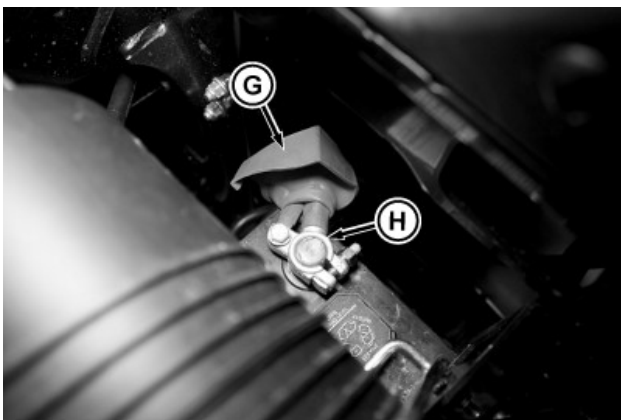

MXT020781—UN—29AUG17

7. Slide back rubber protective cover (G) and disconnect the positive (+) battery cable (H) from the battery.
8. Remove battery from the machine.

Installing

1. Install battery half way into the battery tray with the negative (-) terminal positioned toward the rear of the machine.
2. Connect positive (+) cable to positive (+) battery terminal. Tighten the hardware.
3. Apply general-purpose grease or silicone spray to positive (+) battery terminal to help prevent corrosion.
4. Slide protective cover down the positive (+) cable and seat it over the positive (+) terminal.
5. Slide the battery forward until it is properly seated in the tray.

NOTE: On winch ready machines, be sure that the mounting bracket (A) is clear of the negative (-) cable (B) for the winch power.

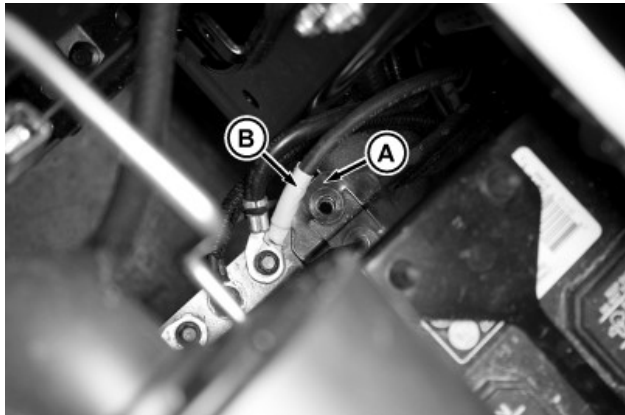

MXT020782—UN—29AUG17

6. Slide the mounting bracket over the negative (-) post and install with two screws. Tighten the screws.
7. Connect negative (-) cable to negative (-) battery terminal. Tighten the hardware.
8. Apply general-purpose grease or silicone spray to negative (-) battery terminal to help prevent corrosion.
9. Install the side panel.
10. Install air cleaner cover.
11. Lower the cargo box.

MX10673,0000033-19-08SEP17

Cleaning Battery and Terminals

1. Park machine safely. (See Parking Safely in the SAFETY section.)
2. Disconnect and remove battery.
3. Wash battery with solution of four tablespoons of baking soda to one gallon of water. Be careful not to get the soda solution into the cells.
4. Rinse the battery with plain water and dry.
5. Clean terminals and battery cable ends with wire brush until bright.
6. Install battery.
7. Attach cables to battery terminals, beginning with the positive cable, using washers and nuts.
8. Apply spray lubricant to terminal to prevent corrosion.

MP47322,00F4671-19-15MAR13

Service Electrical

Using Booster Battery

CAUTION: Avoid injury! The battery produces a flammable and explosive gas.

To prevent the battery from exploding:

- Do not smoke or have open flame near battery.
- Wear eye protection and gloves.
- Do not jump-start or charge a frozen battery. Warm battery to specification.

Specification

Battery—Temperature. 16°C (60°F)

- Do not connect the negative (-) booster cable to the negative (-) terminal of the discharged battery. Connect at a good ground location away from the discharged battery.

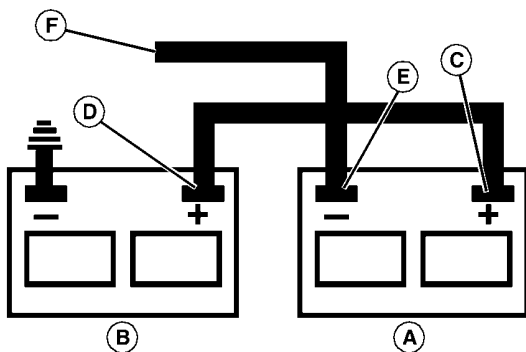

MXAL42872—UN—09APR13

- A—Booster Battery
- B—Disabled Vehicle Battery
- C—Positive (+) Post
- D—Positive (+) Post
- E—Negative (-) Post
- F—Negative (-) Booster Cable End

1. Connect positive (+) booster cable to booster battery (A) positive (+) post (C).
2. Connect the other end of positive (+) booster cable to the disabled vehicle battery (B) positive (+) post (D).
3. Connect negative (-) booster cable to booster battery negative (-) post (E).

IMPORTANT: Avoid damage! Electric charges from the booster battery damages machine components. Do not install negative booster cable to machine frame. Install only to the engine block.

Install negative booster cable away from moving parts in the engine compartment, such as belts and fan blades.

4. Connect the other end (F) of negative (-) booster cable to a metal part of the disabled machine engine block away from battery.

5. Start the engine of the disabled machine and run machine for several minutes.
6. Carefully disconnect the booster cables in the exact reverse order: negative cable first and then the positive cable.

MP47322.00F4672-19-05JUN15

Replacing Headlight

1. Park the machine safely. (See Parking Safely in the SAFETY section.)
2. Locate headlight housing under the front fender.

Standard Bulbs

CAUTION: Avoid injury! Halogen light bulb contains gas under pressure. The bulb may shatter if the glass is scratched or dropped. Wear eye protection and handle bulb with care when replacing.

IMPORTANT: Avoid damage! Do not touch glass portion of new bulb with bare skin. Contact with oils or dirt reduces bulb life. Handle bulb by the base or with a clean cloth or gloves.

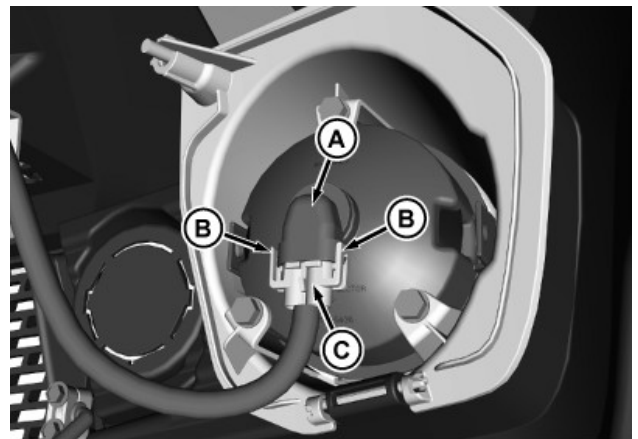

MXT019894—UN—23FEB17

1. Rotate bulb socket (A) 1/8 of a turn counterclockwise and remove the socket from the housing.
2. Pull outward on tabs (B) and disconnect wire connector (C) from socket. Discard the bulb/socket assembly.
3. Connect wiring connector to new bulb/socket assembly. Install the assembly into housing and rotate 1/8 turn clockwise to lock in place.
4. Test headlight function.

Service Electrical

Dual Beam Light

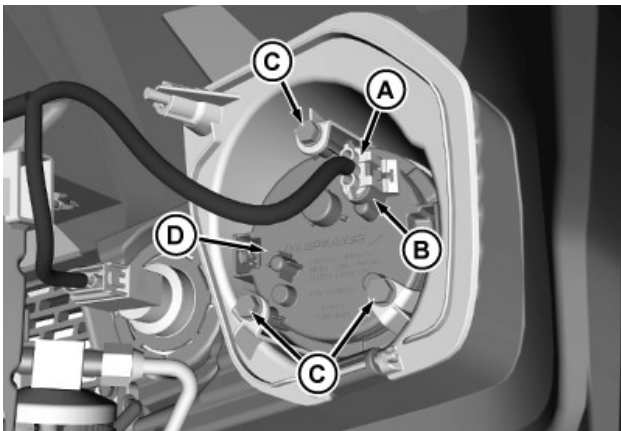

MXT019895—UN—23FEB17

1. Disconnect wiring connector (A) from socket (B).
2. Remove three screws (C).
3. Remove light assembly (D) from bezel.
4. Install new light assembly with three screws.
5. Connect wiring connector to socket.
6. Test headlight function.

OUMX068,0001244-19-23FEB17

Checking and Replacing Fuses

IMPORTANT: Avoid damage! If incorrect replacement fuses are used, the electrical system can be damaged. Replace the bad fuse with a fuse of the same amperage rating.

1. Park the machine safely. (See Parking Safely in the SAFETY section.)
2. Open the hood.

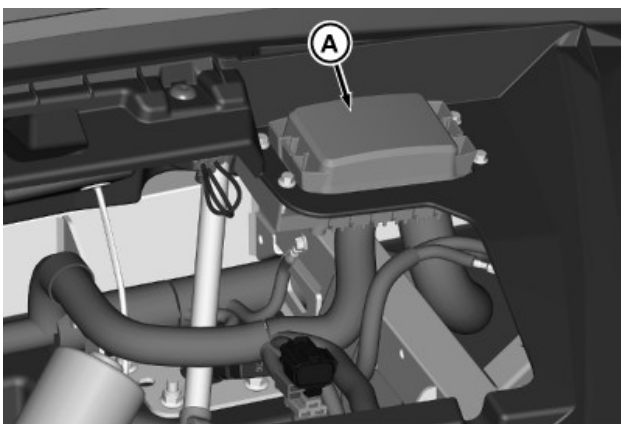

MXT020089—UN—05APR17

3. Remove load center cover (A).

Load Center—E Series

1. Fuse identification:

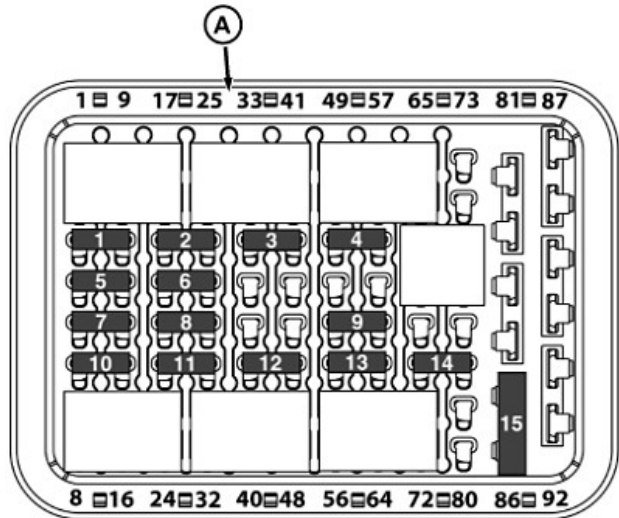

MXT020086—UN—05APR17

Position	Circuit	Fuse Size
1	AMS Component Power	10 A
2	Auxiliary	20 A
3	Fuel Pull-In	25 A
4	Flasher Module	15 A
5	Battery Power	20 A
6	Headlights	10 A
7	Starter Motor Solenoid	20 A
8	Work Lights	20 A
9	Dash Power Port	10 A
10	Ignition Key Switch Power	20 A
11	Relayed Key Power	20 A
12	Dash Attachments Power	20 A
13	Glow Plug	30 A
14	Diagnostic Power	5 A
15	Engine Fan	30 A

2. Pull fuse from the load center (A).
3. Look for a broken filament in the fuse. (See Checking Fuse Filaments in SERVICE MISCELLANEOUS section.)
4. Push new fuse of the correct amperage rating into correct position in the load center.
5. Install cover and close hood.

Load Center—M Series

1. Fuse identification:

Service Electrical

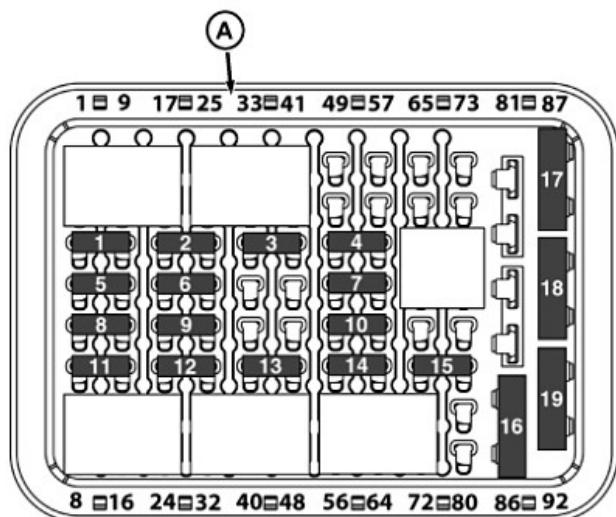

MXT020087—UN—05APR17

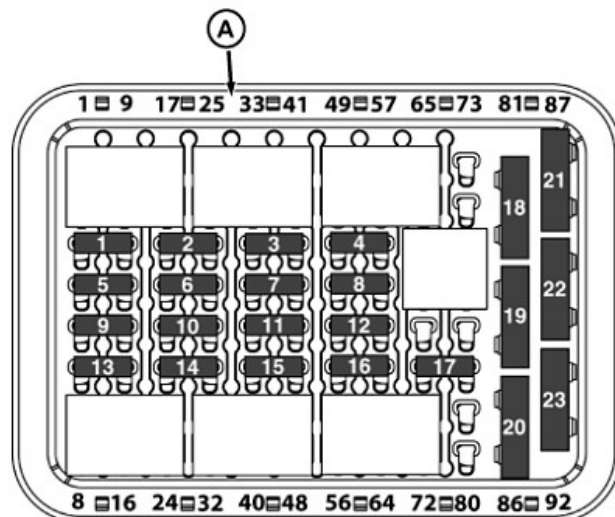

MXT020088—UN—04APR17

Position	Circuit	Fuse Size
1	AMS Component Power	10 A
2	Auxiliary	20 A
3	Fuel Pull-In	25 A
4	Flasher Module	15 A
5	Battery Power	20 A
6	Headlights	10 A
7	Glove Box Power Port	10 A
8	Starter Motor Solenoid	20 A
9	Work Lights	20 A
10	Dash Power Port	10 A
11	Ignition Key Switch Power	20 A
12	Relayed Key Power	20 A
13	Dash Attachments	20 A
14	Glow Plug	30 A
15	Diagnostic Power	5 A
16	Engine Fan	30 A
17	Load Shed	40 A
18	Front Attachment Power	20 A
19	Dash Attachment Power	20 A

Position	Circuit	Fuse Size
1	AMS Component Power	10 A
2	Auxiliary	20 A
3	Fuel Pull-In	25 A
4	Flasher Module	15 A
5	Battery Power	20 A
6	Headlights	10 A
7	HVAC Compressor	7.5 A
8	Glove Box Power Port	10 A
9	Starter Motor Solenoid	20 A
10	Work Lights	20 A
11	HVAC Controller	10 A
12	Dash Power Port	10 A
13	Ignition Key Switch Power	20 A
14	Relayed Key Power	20 A
15	Dash Attachments	20 A
16	Glow Plug	30 A
17	Diagnostic Power	5 A
18	HVAC Fan	30 A
19	HVAC Blower Motor	25 A
20	Engine Fan	30 A
21	Load Shed	40 A
22	Front Attachment Power	20 A
23	Dash Attachment Power	20 A

2. Pull fuse from the load center (A).
3. Look for a broken filament in the fuse. (See Checking Fuse Filaments in SERVICE MISCELLANEOUS section.)
4. Push new fuse of the correct amperage rating into correct position in the load center.
5. Install cover and close hood.

Load Center—R, M Series with A/C

1. Fuse identification:

2. Pull fuse from the load center (A).
3. Look for a broken filament in the fuse. (See Checking Fuse Filaments in SERVICE MISCELLANEOUS section.)
4. Push new fuse of the correct amperage rating into correct position in the load center.
5. Install cover and close hood.

Rear Attachment Fuse

1. Raise cargo box.

Service Electrical

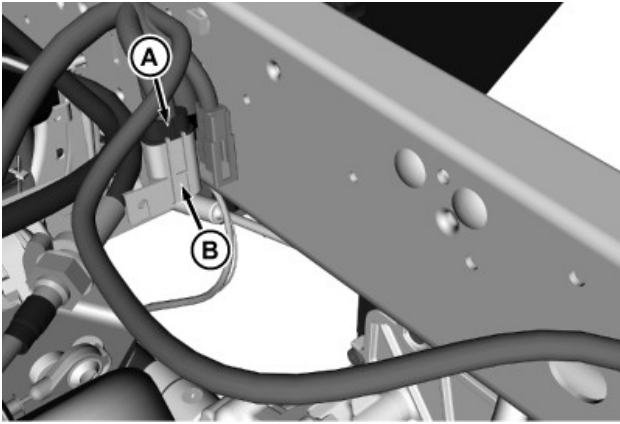

MXT020090—UN—11APR17

2. Locate fuse holder (A) on the right rear frame.
3. Remove cover (B) and remove fuse.
4. Look for a broken filament in the fuse. (See Checking Fuse Filaments in SERVICE MISCELLANEOUS section.)
5. Push new fuse of the correct amperage rating into fuse holder:

Position	Circuit	Fuse Size
—	Rear Attachment	40 A

6. Install cover on the fuse holder.
7. Lower cargo box.

Electronic Power Assisted Steering (EPAS) Fuse (If Equipped)

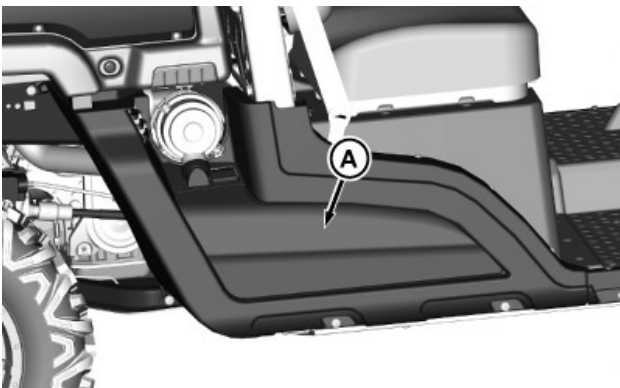

MXT020098—UN—25APR17

1. Remove access panel (A).

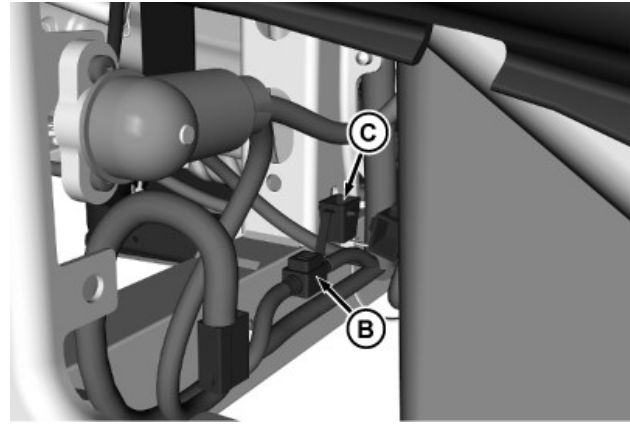

MXT020092—UN—11APR17

Components hidden for a better view.

2. Locate fuse holder (B).
3. Remove cover (C) and remove fuse.
4. Look for a broken filament in the fuse. (See Checking Fuse Filaments in SERVICE MISCELLANEOUS section.)
5. Push new fuse of the correct amperage rating into fuse holder:

Position	Circuit	Fuse Size
—	Electronic Power Assisted Steering (EPAS)	50 A

6. Install cover on the fuse holder.
7. Install access panel.

Winch Power Harness Fuse (If Equipped)

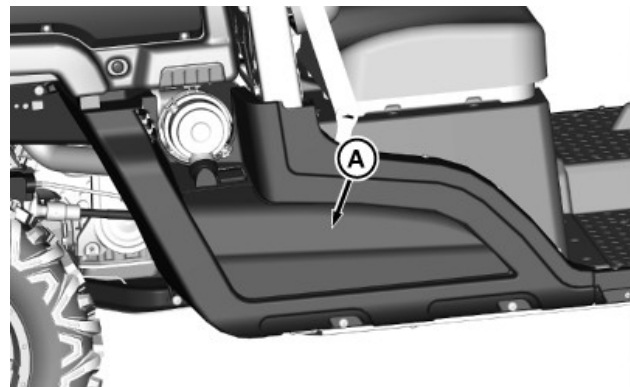

MXT020098—UN—25APR17

1. Remove access panel (A).

Service Electrical

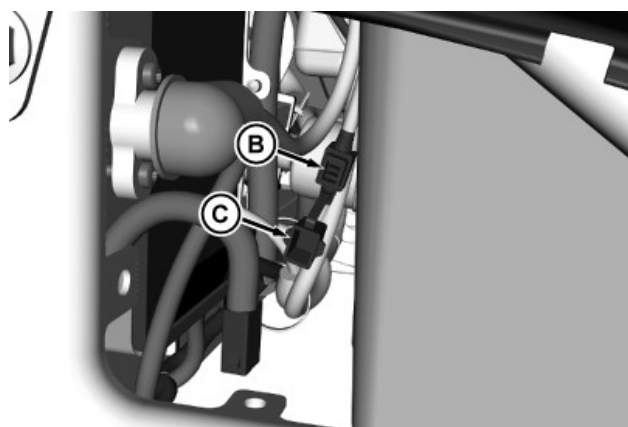

MXT020093—UN—11APR17

2. Locate fuse holder (B).
3. Remove cover (C) and remove fuse.
4. Look for a broken filament in the fuse. (See Checking Fuse Filaments in SERVICE MISCELLANEOUS section.)
5. Push new fuse of the correct amperage rating into fuse holder:

Position	Circuit	Fuse Size
—	Winch Power Harness	40 A

6. Install cover on the fuse holder.
7. Install access panel.

OUMX068,0001282-19-31AUG18

Replacing LED Work Lights

Front Light

1. Park the machine safely. (See Parking Safely in the SAFETY section.)
2. Remove the headliner, if equipped.

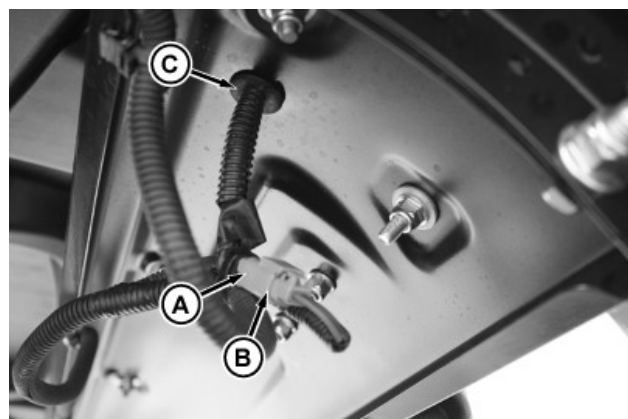

MXT020783—UN—30AUG17

3. Unplug light harness connector (A) from the roof harness connector (B).

4. Push grommet (C) and light harness through the hole in Protective Structure. Remove grommet from light harness.

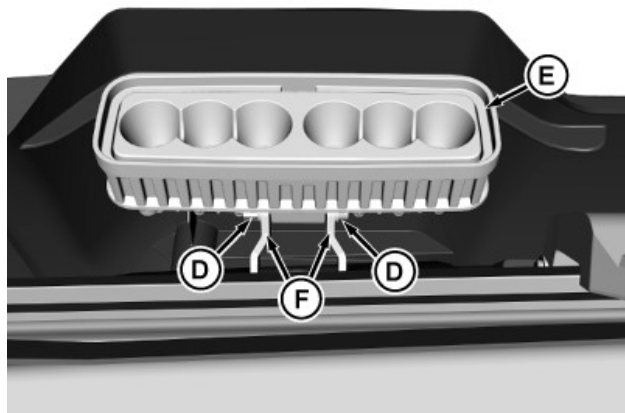

MXT020784—UN—30AUG17

5. Remove hardware (D) securing light assembly (E) to bracket (F) and remove light assembly.
6. Loosely install new light assembly to bracket with hardware.
7. Route the light harness through the hole in the Protective Structure.
8. Plug light harness connector into the roof harness connector.
9. Install grommet onto light harness and press into the hole in the Protective Structure. Make sure that the grommet is seated properly.
10. Position the light as desired and tighten the hardware.
11. Install the headliner, if equipped.

Rear Light

1. Park the machine safely. (See Parking Safely in the SAFETY section.)

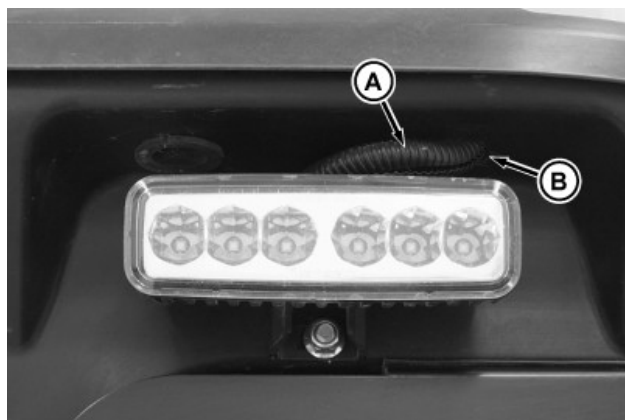

MXT020785—UN—30AUG17

2. To access light harness connector, pull light harness (A) out from the hole (B) in the roof.
3. Unplug light harness connector from the roof harness connector.

Service Electrical

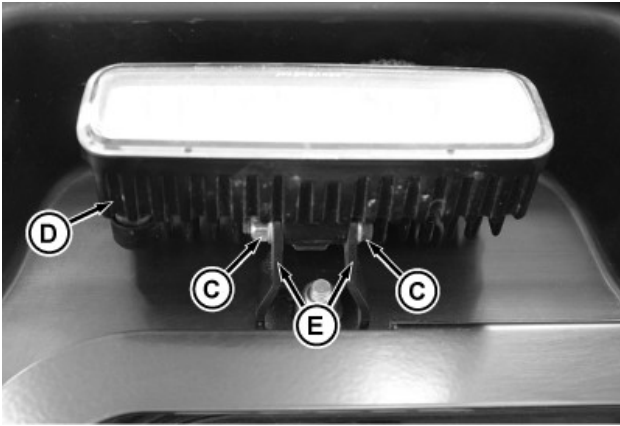

MXT020786—UN—30AUG17

4. Remove hardware (C) securing light assembly (D) to bracket (E) and remove light assembly.
5. Loosely install new light assembly to bracket with hardware.
6. Plug light harness connector into the roof harness connector.
7. Route light and roof harness back through the hole in the roof.
8. Position the light as desired and tighten the hardware.

OUMX068,0001370-19-08SEP17

Service Miscellaneous

Diesel Fuel

Consult your local fuel distributor for properties of the diesel fuel available in your area.

In general, diesel fuels are blended to satisfy the low temperature requirements of the geographical area in which they are marketed.

Diesel fuels specified to EN 590 or ASTM D975 are recommended.

Required Fuel Properties

In all cases, the fuel shall meet the following properties:

Cetane number of 45 minimum. Cetane number greater than 47 is preferred, especially for temperatures below -20°C (-4°F) or elevations above 1675 m (5500 ft).

Cloud Point should be below the expected lowest ambient temperature or **Cold Filter Plugging Point** (CFPP) should be a maximum 10°C (18°F) below the fuel cloud point.

Fuel lubricity should pass a maximum scar diameter of 0.52 mm (0.018 in) as measured by ASTM D6079 or ISO 12156-1. A maximum scar diameter of 0.45 mm (0.020 in) is preferred.

Diesel fuel quality and sulfur content must comply with all existing emissions regulations for the area in which the engine operates. DO NOT use diesel fuel with sulfur content greater than 5000 mg/kg (5000 ppm).

E-Diesel fuel

DO NOT use E-Diesel (Diesel fuel and ethanol blend). Use of E-Diesel fuel in any John Deere machine may void the machine warranty.

CAUTION: Avoid injury! Avoid severe injury or death due to the fire and explosion risk from using E-Diesel fuel.

Sulfur content for Interim Tier 4, Final Tier 4, Stage III B, Stage IV Engines, and Stage V engines

- Use ONLY ultra-low sulfur diesel (ULSD) fuel with a maximum of 15 mg/kg (15 ppm) sulfur content.

Sulfur Content for Tier 3 and Stage III A Engines greater than 37 kW

- Use of diesel fuel with sulfur content less than 1000 mg/kg (1000 ppm) is REQUIRED.

Sulfur Content for other Engines

- Use of diesel fuel with sulfur content less than 2000 mg/kg (2000 ppm) is RECOMMENDED.
- Use of diesel fuel with sulfur content 2000—5000 mg/kg (2000—5000 ppm) REDUCES the oil and filter change interval. Contact your dealer.

IMPORTANT: Avoid damage! Do not mix used diesel engine oil or any other type of lubricating oil with diesel fuel.

Improper fuel additive usage may cause damage to fuel injection equipment of diesel engines.

MK71445,0000080-19-01AUG18

Biodiesel Fuel

Biodiesel fuel is comprised of monoalkyl esters of long chain fatty acids derived from vegetable oils or animal fats. Biodiesel blends are biodiesel mixed with petroleum diesel fuel on a volume basis.

Before using fuel containing biodiesel, review the Biodiesel Use Requirements and Recommendations in this Operator's Manual.

Environmental laws and regulations can encourage or prohibit the use of biofuels. Operators should consult with appropriate governmental authorities prior to using biofuels.

Stage V Engines Operating in the European Union

Where the engine is to be operated within the Union on diesel or non-road gas-oil, a fuel with a FAME content not greater than 8% volume/volume (B8) shall be used.

Engines Except Stage V Engines Operating in the European Union

Biodiesel blends up to B20 can be used ONLY if the biodiesel (100% biodiesel or B100) meets ASTM D6751, EN 14214, or equivalent specification. Expect a 2% reduction in power and a 3% reduction in fuel economy when using B20.

Biodiesel blends above B20 cannot be used.

Biodiesel Use Requirements and Recommendations

The petroleum diesel portion of all biodiesel blends must meet the requirements of ASTM D975 (US) or EN 590 (EU) commercial standard.

Biodiesel users in the U.S. are strongly encouraged to purchase biodiesel blends from a BQ-9000 Certified Marketer and sourced from a BQ-9000 Accredited Producer (as certified by the National Biodiesel Board). Certified Marketers and Accredited Producers can be found at the following website: <http://www.bq9000.org>.

Biodiesel contains residual ash. Ash levels exceeding the maximums allowed in either ASTM D6751 or EN14214 can result in more rapid ash loading and require more frequent cleaning of the exhaust filter (if present).

The fuel filter can require more frequent replacement when using biodiesel fuel, particularly if switching from diesel. Check engine oil level daily prior to starting engine. A rising oil level can indicate fuel dilution of the

Service Miscellaneous

engine oil. Biodiesel blends up to B20 must be used within 90 days of the date of biodiesel manufacture.

When using biodiesel blends up to B20, the following must be considered:

- Cold-weather flow degradation
- Stability and storage issues (moisture absorption, microbial growth)
- Possible filter restriction and plugging (usually a problem when first switching to biodiesel on used engines)
- Possible fuel leakage through seals and hoses (primarily an issue with older engines)
- Possible reduction of service life of engine components

Request a certificate of analysis from your fuel distributor to ensure that the fuel is compliant with the specifications provided in this Operator's Manual.

Consult your John Deere dealer for John Deere fuel products to improve storage and performance with biodiesel fuels.

MK71445,0000081-19-01AUG18

Filling Fuel Tank

CAUTION: Avoid injury! Fuel vapors are explosive and flammable:

- Shut engine off before filling fuel tank.
- Allow engine to cool before refueling.
- Do not smoke while handling fuel.
- Keep fuel away from flames or sparks.
- Fill fuel tank outdoors or in ventilated area.
- Clean up spilled fuel immediately.
- To prevent static electric discharge, use a clean, approved non-metal container.

IMPORTANT: Avoid damage! Dirt and water in fuel causes engine damage:

- Clean dirt and debris from the fuel tank opening.
- Use clean, fresh, stabilized fuel.
- To keep condensation out of the fuel tank, fill the fuel tank at the end of operation each day.
- If using a funnel, make sure it is plastic and has no screen or filter.

To prevent condensation and freezing during cold weather, fill fuel tank at the end of operation each day.

1. Park machine safely. (See Parking Safely in the Safety section.)
2. Allow engine to cool.

3. Remove any trash from area around fuel tank cap.
4. Remove fuel tank cap slowly to allow any pressure built up in tank to escape.
5. Fill fuel tank only to bottom of filler neck. Do not overfill.
6. Install fuel tank cap.
 - Gas models: turn cap until it clicks.

MP47322,00F4675-19-05JUL17

Removing and Installing Wheel Assembly

Removing

1. Park machine safely. (See Parking Safely in the SAFETY section.)

CAUTION: The machine can fall or slip from an unsafe lifting device or supports.

- Use a safe lifting device rated for the load to be lifted.
- Lower machine onto jack stands or other stable supports and block wheels before servicing.

IMPORTANT: Place jack stands under frame, not under transmission or engine, when raising or supporting machine.

2. Raise machine with a safe lifting device and lower machine onto jack stands or other stable supports. Block wheels remaining on the ground to prevent machine movement.

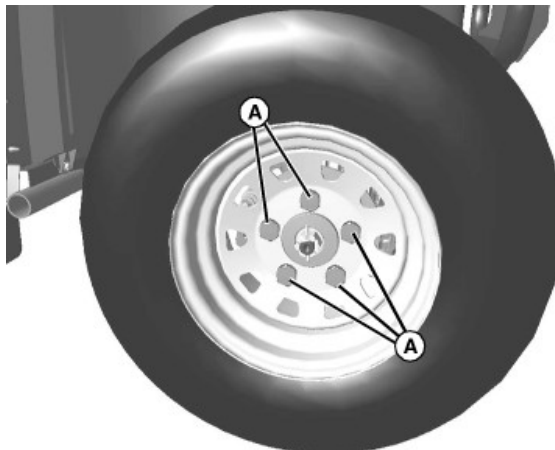

MXAL44281—UN—10APR13

Wheel may or may not have a cap to remove when removing the wheel.

3. Remove the wheel bolts (A).
4. Remove the wheel assembly.

Service Miscellaneous

CAUTION: Explosive separation of tire and rim parts is possible when they are serviced incorrectly:

- Do not attempt to mount a tire without the proper equipment and experience to perform the job.

5. Take wheel assembly to an authorized service dealer for repairs.

Installing

1. Install wheel assembly with valve stem to the outside.
2. Tighten wheel bolts evenly in alternating sequence until snug.
3. Lower machine completely to the ground.
4. Tighten wheel bolts to:
 - Standard wheel assembly - 108 N·m (80 lb-ft)
 - Sport wheel assembly - 142 N·m (105 lb-ft)
5. If new bolts or wheels are used, tighten wheel bolts again after 8 hours of vehicle use.

MP47322,00F489A-19-03APR13

Removing and Installing Seats

Removing and Installing Bucket Seat

1. Tip seat forward.

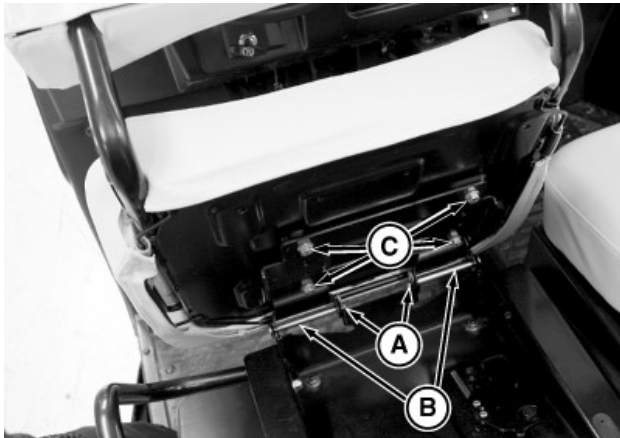

2. Remove cotter pins (A) and drilled pins (B).
3. If removing seat from bracket, remove bolts (C).
4. Remove seat from the bracket.
5. Installation is the reverse of removal.
6. Tighten seat bracket bolts to specification:

Specification

Seat Bracket Bolts—Torque. 10 N·m (7.4 lb-ft)

Removing and Installing Bench Seat

1. Tip seat forward.

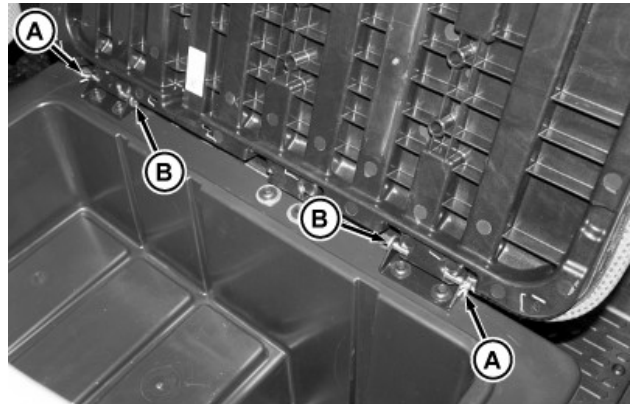

2. Remove spring locking pins (A) and pins (B).
3. Remove seat from brackets.
4. Installation is the reverse of removal.

OUMX068,0001245-19-24AUG17

Replacing Cab Air Filter (If Equipped)

1. Park the machine safely. (See Parking Safely in the SAFETY section.)

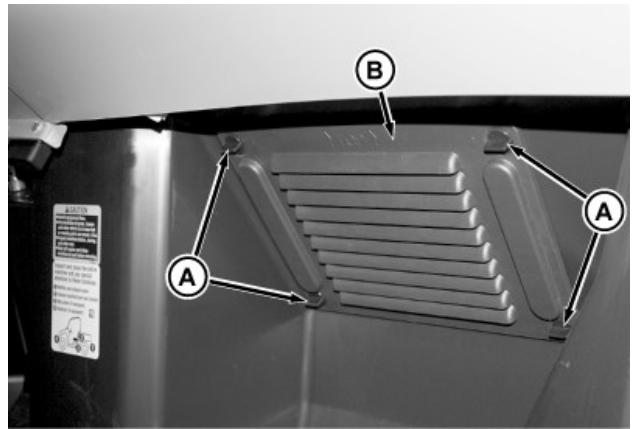

2. Rotate four knobs (A) a 1/4 turn and remove filter cover (B).

Service Miscellaneous



MXT019899—UN—24FEB17

3. Remove and inspect filter (C). Replace as necessary.
4. Install new filter. Make sure that the arrows on the filter point up.
5. Install filter cover.

OUMX068,0001246-19-08SEP17

Lifting Machine

1. Park machine safely. (See Parking Safely in the SAFETY section.)

CAUTION: Avoid injury! The machine can fall or slip from an unsafe lifting device or supports.

- Use a safe lifting device rated for the load to be lifted.
- Lower machine onto jack stands or other stable supports and block wheels before servicing.

IMPORTANT: Avoid damage! To prevent slipping, be certain to include bolt heads (A) and embossed area (B) inside the jack cup.

NOTE: Remove all attachments before lifting machine.

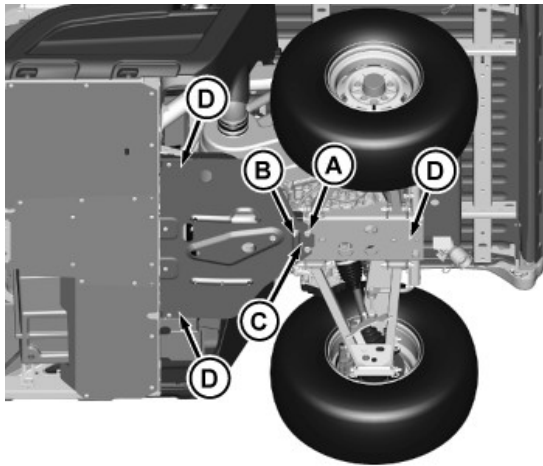

MXT020830—UN—09SEP17

Your machine model may not be shown, but jack locations are as shown.

2. Safely lift the rear of the machine at frame point (C).
3. Place jack stands or other stable supports under three frame locations (D).
4. If only lifting rear of machine, block front wheels remaining on ground to avoid movement of the machine.

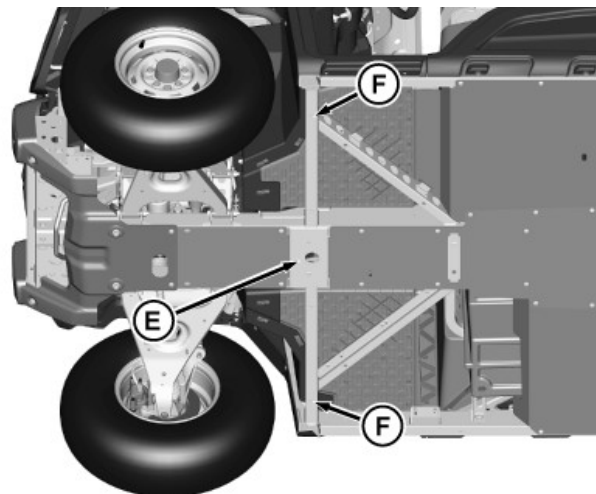

MXT019902—UN—27FEB17

Your machine model may not be shown, but jack locations are as shown.

5. Safely lift the front of the machine at frame point (E) or locations (F). Place jack stands or other stable supports under two machine frame locations (F).
6. If only lifting front of machine, block rear wheels remaining on ground to avoid movement of the machine.
7. To lower the machine, lift front and/or rear of machine, and remove jack stands or supports. Lower machine.

OUMX068,0001247-19-09SEP17

Service Miscellaneous

Opening and Closing Hood

CAUTION: Avoid injury! Never store flammable, heavy, or loose breakable objects in the storage tray. Always latch hood before operating machine.

IMPORTANT: Avoid damage! Do not store items that prevent the hood from closing properly. Properly secure loose or sharp items, which damage the storage tray or other items within the tray.

1. Park the machine safely. (See Parking Safely in the SAFETY section.)

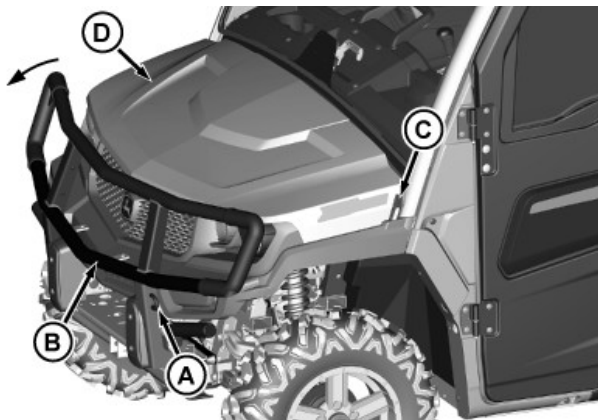

MXT019906—UN—28FEB17

2. Pull out on locking pin (A) on each side of the front bumper (B).
3. Rotate the top of the front bumper forward.
4. Release the rubber latch (C) attached to each side of the hood (D).
5. Raise the hood.
6. Close hood. Secure with two rubber latches.
7. Lower front bumper and secure with locking pins.

OUMX068,0001249-19-28FEB17

Inspecting Seat Belt



MXT019907—UN—28FEB17

IMPORTANT: Avoid damage! Do not bleach or dye webbing. Webbing could become severely weakened by this process. Do not use a pressure washer or other automatic washing machine to clean belt or connectors.

- Hand wash webbing (A) with warm water and mild soap. Rinse thoroughly and air dry.
- Inspect outer seat belt connector (B) and inner connector (C) for damage or wear. If assembly does not operate properly or if the webbing is torn or frayed, the seat belt must be replaced.

OUMX068,000124A-19-28FEB17

Inspecting Nets or Doors

- Keep nets, doors, and supporting components clean.
- If needed hand wash with garden hose and mild soap.
- Latch and unlatch metal tab of net from buckle during washing for better cleaning. Allow to dry before use.
- Extended machine operation under harsh conditions may require more frequent inspection and cleaning.

OUMX068,00002E5-19-04OCT13

Service Miscellaneous

Cleaning and Repairing Cargo Box

Repairing Accessory Tubes

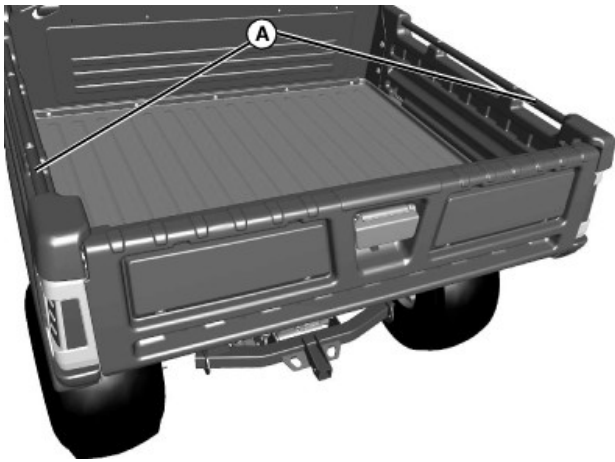

MXAL44293—UN—10APR13

Use 3M™ Scotchbrite™ pad to polish and smooth nicks, scrapes or scratches in the vinyl surface of the tubes (A).

Cargo Box Floor

A rejuvenating product is available for cargo boxes with the optional spray-in liner. See your John Deere dealer.

MP47322.00F48A0-19-03APR13

Checking Fuse Filaments

1. Remove fuse.

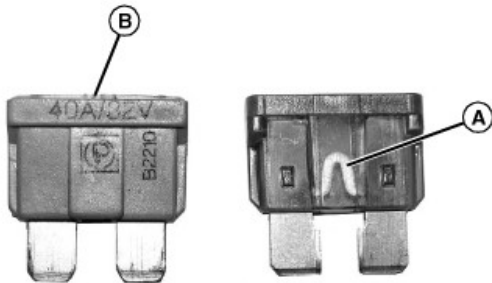

MXAL44294—UN—10APR13

2. Check visually for broken filament:

- For clear housing fuses, check filament (A).
- For all other fuses, check filament (B) in top of fuse housing.

MP47322.00F48A1-19-03APR13

Replacing Cargo Box Tailgate Bushings

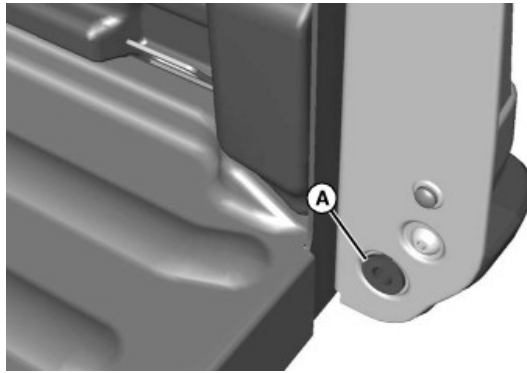

MXAL44295—UN—10APR13

1. Remove the cargo box tailgate (See Removing the Tailgate in OPERATING).
2. Remove snapfit bushing (A) from both sides of cargo box.
3. Replace bushings and reinstall the tailgate.

MP47322.00F48A2-19-03APR13

Checking and Adjusting Toe-In

In order to set front wheel toe-in accurately, suspension and steering components must be in good condition. All fasteners must be tightened to specification.

1. Park machine safely. (See Parking Safely in the SAFETY section.)
2. Turn steering wheel so that front tires are in straight-ahead position.
3. Check tire pressure. Adjust to specification if needed (See SPECIFICATIONS section).



MXAL44296—UN—10APR13

4. Measure front wheel center height (A) from surface.
5. Mark tread centerline (B) and hub center height at front and back of both front tires.

Service Miscellaneous

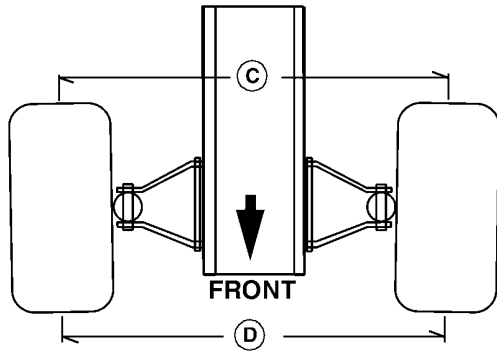

MXAL44297—UN—10APR13

6. Measure distance (C) between tread centerlines at the rear of the tires at hub height.
7. Measure distance (D) between tread centerlines at the front of the tires at hub height.
8. Subtract front measurement from rear measurement and determine toe-in.
9. Adjust toe-in if not within specification:

Specification

Tire Centerline—Distance. 4±3 mm (0.16±0.12 in)

NOTE: If the boot clamp (G) is too tight, the steering rack boot may turn with the tie rod. If the boot rotates, loosen the boot clamp enough to allow the boot to remain stationary when the tie rod is turned.

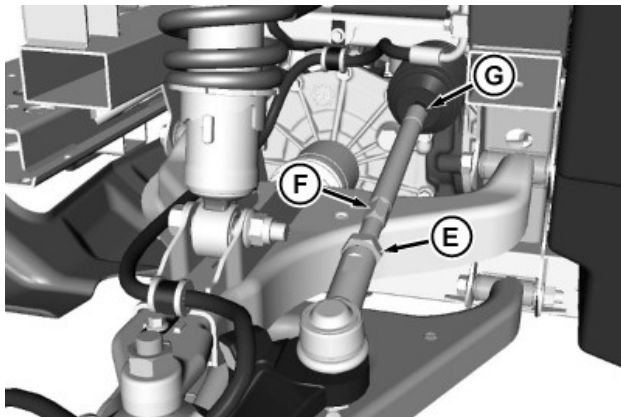

MXT019908—UN—01MAR17

Left front side shown.

- a. Loosen nuts (E) on left and right tie rod.
- b. Rotate tie rod by placing wrench on hex (F).
- c. Loosen boot clamps (G) if boots rotate with tie rod adjustment.
- d. Adjust left and right tie rods equally until the toe-in is within specification.
- e. Tighten nuts to specification.

Specification

Nuts—Torque. 33—55 N·m (24—41 lb-ft)

- f. Check that front tires do not contact suspension when fully turned left or right.

OUMX068,000124B-19-01MAR17

Adjusting Suspension (Standard Shocks)

Preload Adjustment

When to Adjust:

- Front preload adjustment - increase preload if operating with front attachment or under heavy load condition.
- Rear preload adjustment - increase preload if operating under heavy load condition.

How to Adjust:

1. Park machine safely. (See Parking Safely in the SAFETY section).
2. Block tire not intended to be lifted off the ground.
3. Raise the machine with a safe lifting device and lower machine onto jack stands or other stable support.

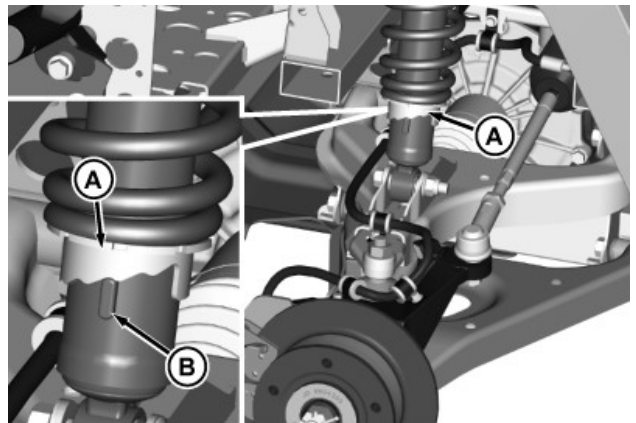

MXT019909—UN—01MAR17

Left front side shown.

4. Using the supplied spanner wrench, securely engage the adjustable preload collar (A) on shock. Rotate preload collar to desired preload condition making sure to engage detent feature (B) between shock and preload collar.

CAUTION: Avoid injury! Be sure that both front preload collars are set to the same position. Be sure that both rear preload collars are set to the same position.

5. Repeat procedure on all shocks as needed.

OUMX068,000124C-19-01MAR17

Service Miscellaneous

Cleaning Vehicle Surfaces

Cleaning:

Keeping your vehicle clean will maintain its appearance and can also extend the life of various components. Immediately after your vehicle has been exposed to salt water or operated on muddy trails, rough terrain, or in dusty conditions, wash your vehicle. With some precautions, your vehicle can be cleaned much like a sport utility vehicle.

IMPORTANT: Improper care of machine plastic surfaces can damage that surface:

- Do not wipe plastic surfaces when they are dry. Dry wiping will result in minor surface scratches.
- Use a soft, clean cloth (bath towel, diaper, automotive mitt).
- Do not use abrasive materials, such as polishing compounds, on plastic surfaces.

Washing Vehicle:

The recommended and safest way to clean your vehicle is with a garden hose and a pail of mild, soapy water. Use a professional type wash mitt. Clean the upper body first and the lower parts last. Rinse frequently with water and dry with a chamois to prevent water spotting.

1. Rinse hood and entire machine with clean water to remove dirt and dust that may scratch the surface.

IMPORTANT: High pressure may damage vehicle components. It is recommended that your vehicle be washed by hand or with a garden hose using mild soap.

Avoid spraying water with any great force near or into the following places:

- Clutch enclosure air outlet
- Air intake
- Electrical connections (including battery compartment)
- CV boots
- Wheel bearings
- Master cylinder
- Pillow block bearings
- Radiator
- Warning labels
- Decals
- Ignition switch
- Instrument panel (gauges and switches)
- Breather/tube vents

2. Wash surface with clean water and a mild liquid automotive washing soap.

3. Immediately after washing, lubricate all grease fittings with grease.
4. Dry thoroughly to avoid water spots.
5. Wax the surface with a liquid automotive wax. Use products that specifically say "contains no abrasives."

IMPORTANT: Do not use a power buffer to remove wax.

6. Buff applied wax by hand using a clean, soft cloth.

MP47322,00F48A6-19-04APR13

Cleaning and Repairing Metal Surfaces

Cleaning:

Follow automotive practices to care for your vehicle painted metal surfaces. Use a high-quality automotive wax regularly to maintain the factory look of your vehicle's painted surfaces.

Repairing Minor Scratches (surface scratch):

1. Clean area to be repaired thoroughly.

IMPORTANT: Avoid damage! Do not use rubbing compound on painted surfaces.

2. Use automotive polishing compound to remove surface scratches.
3. Apply wax to entire surface.

Repairing Deep Scratches (bare metal or primer showing):

1. Clean area to be repaired with rubbing alcohol or mineral spirits.
2. Use paint stick with factory-matched colors available from your authorized dealer to fill scratches. Follow directions included on paint stick for use and for drying.
3. Smooth out surface using an automotive polishing compound. Do not use power buffer.
4. Apply wax to surface.

MP47322,00F467A-19-26MAY15

Cleaning Plastic Hood and Body Panel Surfaces

IMPORTANT: Improper care of machine plastic surfaces can damage that surface:

- Do not wipe plastic surfaces when they are dry. Dry wiping will result in minor surface scratches.
- Use a soft, clean cloth (bath towel, diaper, automotive mitt).

Service Miscellaneous

- **Do not use abrasive materials, such as polishing compounds, on plastic surfaces.**

1. Rinse with clean water to remove dirt and dust.
2. Dry thoroughly to avoid water spots.
3. Spray PLEDGE® onto hood and surfaces and leave on for 30 to 60 seconds.
4. Wipe off with cheesecloth to bring out lustre.

MP47322,00F48A8-19-03APR13

Windshield Maintenance

Inspecting Windshield

 **CAUTION: Avoid injury! If cracks or surface crazing are observed, or viewing through windshield is impaired, replace windshield.**

1. Inspect windshield condition.
2. Fill in existing scratches.
3. Polish or wax windows regularly.

Cleaning Windshield

IMPORTANT: Avoid damage! Some cleaning compounds may attack the polycarbonate material, resulting in cracks that weaken the material.

Never use compounds that contain substances such as ammonia, gasoline, lacquer thinner, and turpentine.

Use of abrasive cleaners on windshield may cause damage.

Never use substances such as acetic acid, acetone, benzene, benzyl alcohol, brake fluid, butyric acid, carbon tetrachloride, ethyl ether, methyl alcohol, phenol, sodium sulfide, sodium hydroxide, sodium nitrate, trichloroethylene, toluene, xylene, or petroleum products.

NOTE: The windshield and windscreen are a polycarbonate material which is softer, but stronger than, glass.

The following cleaning agents are compatible with polycarbonate when used according to the manufacturer's recommendations: Formula 409® (without ammonia), Joy®, Ultra Palmolive® Original, Top Job®, Mr. Clean®, and Fantastik®.

*Formula 409 is a trademark of The Clorox Company
Joy is a trademark of Procter & Gamble
Palmolive is a trademark of The Colgate-Palmolive Company
Top Job is a trademark of KIK Custom Products
Mr. Clean is a trademark of Procter & Gamble
Fantastik is a trademark of SC Johnson*

1. Rinse as much loose dirt off as possible with warm water and a soft cloth or sponge before washing.
2. Wash with mild soap or detergent and rinse thoroughly with clean water.
3. Cleaning in direct sunlight causes streaking on surface.
4. Thoroughly dry windshield with a chamois or moist sponge to prevent water spots.

Polishing or Waxing Windshield

Minimize scratches and minor abrasions with a mild automobile polish.

Test effectiveness of polish or wax in a small corner of windshield before using on entire windshield.

OUMX068,000BC0-19-05MAY15

Troubleshooting

Using Troubleshooting Chart

If you are experiencing a problem that is not listed in this chart, see your Technical Manual or authorized dealer for service.

MP47322,00F467B-19-07SEP17

Engine

IF	CHECK
Engine will not start	Wrong Engine oil viscosity. Battery has low voltage. Loose or corroded battery connections. Blown fuse(s). Cold start system not being used, or malfunctioning. Stale fuel/improper fuel/low fuel level. Dirty or Faulty Fuel Injectors. Fuel shut-off valve turned off. No fuel or improper fuel. Plugged fuel filter. Defective starter solenoid. Open-circuit in wiring.
Engine is hard to start	Check glow plug fuse. Engine is cold. Plugged fuel filter. Engine oil viscosity too heavy. Cold start system not being used, or malfunctioning. Dirty or Faulty Fuel Injectors. Loose or corroded electrical connections. Stale or improper fuel. Blown fuse.
Engine misses under load	Stale or dirty fuel. Plugged fuel filter.
Engine vapor locks	Fuel tank vent plugged. Dirt in fuel filter.
Engine runs unevenly	Loose electrical connections. Improper fuel. Stale or dirty fuel. Fuel line or fuel filter plugged. Dirty or faulty fuel injectors. Plugged air intake system.
Engine overheats	Air cleaner element missing or plugged. Defective radiator cap. Engine oil low. Engine operated too long at slow engine speed. Bleed cooling system. Check cooling fan switch. Check thermostat. Check water pump. Clean radiator screens. Check coolant level.
Engine loses power	Engine overheating. Too much oil in engine. Fuel supply being restricted. Fuel filter plugged. Fuel line pinched or kinked. Improper fuel. Air cleaner element plugged. Injection pump out of time. Dirty or faulty fuel injectors. Improper valve clearance.
Engine knocks	Low engine speed. Stale fuel. Engine overloaded. Excessively early timing of fuel injection pump.

MX00654,000011A-19-06SEP13

Troubleshooting

Electrical

IF	CHECK
Starter does not work	Loose or corroded connections. Low battery output. Sulfated or worn out battery. Faulty starter.
Starter cranks slowly	Low battery output. Sulfated or worn out battery. Engine oil too heavy. Loose or corroded connections.
Entire electrical system does not work	Blown fuse. Loose or corroded connections. Sulfated or worn out battery.
Dead battery	Shorted starter solenoid. Ignition key switch not turned to STOP position. Component connected to accessory outlet left on with engine off. Turn signal and/or hazard lights left on with engine off. Sulfated or worn out battery. Low engine speed or excessive idling. Battery cables and terminals are dirty. Dead cell in the battery. Faulty charging system. Current draw higher than charging system output. (If several attachments are added and used frequently at the same time with the standard charging system. Especially at low engine speeds.)
Correct indicator light(s) do not come on when checking instrument panel.	Faulty bulb. Faulty wiring. Faulty switch or sensor.
Battery will not take a charge	Dead cell in battery. Loose or corroded connections. Sulfated or worn out battery. Electrolyte level low. Low engine speed or excessive idling. Faulty charging system.
Headlights dim or flicker	Current draw higher than charging system output. (If installed, Electric Power Assist Steering will draw current.)
Power reduction or cut off to equipment or attachments.	This may be part of load shedding function. See Load Shedding in OPERATING Section.

MX10673,000005F-19-30AUG18

Brakes

IF	CHECK
Brakes not working correctly	Brake fluid level low - check fluid level. Air in brake system, system not bled properly. Replace worn brake pads. (See your John Deere dealer.)

MP47322,00F48AD-19-11APR13

Cargo Box

IF	CHECK
Tailgate doesn't latch properly	Bushings worn/damaged - inspect bushings. Strikers not connecting - inspect and lubricate strikers.
Power lift doesn't operate	No power - check all power connections. Actuator motor overheated - allow actuator to cool.
Power lift actuator ratchets/clicks/squeals when operating	Too much weight in box - remove weight or move it rearward in box.

Troubleshooting

MP47322.00F48AE-19-11APR13

Steering

IF	CHECK
Steering effort feels "heavy"	Current battery draw higher than charging system output amperage. (If installed, Electric Power Assist Steering will draw current.) Turn off optional equipment. Tire pressure or tread below recommended levels. Toe-in may need adjustment. Electric Power Assist Steering (EPAS) malfunction.

MP47322.00F48AF-19-30AUG18

Troubleshooting Diagnostic Trouble Codes (XUV865)

NOTE: In the chart below, "troubleshooting required" means that service by an authorized John Deere dealer is required to resolve the problem.

NOTE: Reference System Settings Menu in the Operating section for information on accessing Diagnostic Trouble Codes (DTC's).

SPN	FMI	Level 1 SYSTEM and CONDITION	Level 2 IMPACT and MITIGATION
84	00	Wheel Speed System Fault	Unable to accurately determine ground speed. Troubleshooting required.
84	09	Wheel Speed Not Detected	Unable to accurately determine ground speed. Troubleshooting required.
84	31	CAN Communication Error	Troubleshooting required.
96	02	Fuel Level System Fault	Unable to accurately determine fuel level. Troubleshooting required.
100	01	Engine Oil Pressure Low	Engine damage may occur. Check oil level. Troubleshooting required.
107	16	Engine Air Filter Restricted	Clean or replace filter.
110	00	Engine Coolant Temperature High	Engine damage may occur. Clean radiator. Check coolant level. Troubleshooting required.
168	00	Charging System Voltage High	Troubleshooting required.
168	01	Charging System Voltage Low	Check battery and battery cable connections. Turn off accessories. Troubleshooting required.
190	00	Engine Speed High	Unable to accurately record engine speed. Troubleshooting required.
629	12	Display Unit Fault	Display will not function. Troubleshooting required.
629	13	Display Unit Fault	Display will not function. Troubleshooting required.
639	12	CAN Communication Error	Troubleshooting required.
639	14	CAN Communication Error	Troubleshooting required.
676	03	Glow Plug Circuit Fault	Loss of battery power. Troubleshooting required.
676	04	Glow Plug Circuit Fault	Difficulty starting engine. Troubleshooting required.
677	03	Starter Relay Circuit Fault	Starter continuously engaged. Troubleshooting required.
677	04	Starter Relay Circuit Fault	Starter will not engage. Troubleshooting required.
677	14	Maximum Crank Time Exceeded	Engine cranking disabled. Cycle ignition switch and wait 60 seconds for starter cool down.
677	31	Maximum Crank Time Exceeded	Engine cranking disabled. Wait 60 seconds for starter cool down.
920	03	Audible Alarm Circuit Fault	Troubleshooting required.
920	04	Audible Alarm Circuit Fault	Audible alarm will not sound. Troubleshooting required.
1071	03	Cooling System Circuit Fault	Radiator fan stays on. Troubleshooting required.
1071	04	Cooling System Circuit Fault	Radiator fan will not turn on. Machine may overheat. Troubleshooting required.
1072	03	Cooling System Circuit Fault	Radiator fan stays on. Troubleshooting required.
1072	04	Cooling System Circuit Fault	Radiator fan will not turn on. Machine may overheat. Troubleshooting required.
3353	03	HVAC System Circuit Fault	Troubleshooting required.
3353	04	HVAC System Circuit Fault	HVAC fan speed will not increase. Troubleshooting required.

Troubleshooting

SPN	FMI	Level 1 SYSTEM and CONDITION	Level 2 IMPACT and MITIGATION
3354	03	Elec Accessory Supply Circuit Fault	Turn accessories off to prevent battery discharge. Troubleshooting required.
3354	04	Elec Accessory Supply Circuit Fault	Accessory loads always off. Troubleshooting required.
516124	03	Fuel Solenoid System Circuit Fault	Troubleshooting required.
516124	04	Fuel Solenoid System Circuit Fault	Engine will not run. Troubleshooting required.
516125	03	Fuel System Circuit Fault	Engine may not start. Troubleshooting required.
516125	04	Fuel System Circuit Fault	Engine will not start. Troubleshooting required.
516182	03	4WD Circuit Fault	4WD continuously engaged. Troubleshooting required.
516182	04	4WD Circuit Fault	4WD will not engage. Troubleshooting required.
517289	07	Service Brake System Fault	Brake performance limited. Check brake fluid level. Troubleshooting required.
520425	07	Communication System Fault CAN Communication Error	Troubleshooting required.
520426	07	Communication System Fault CAN Communication Error	Troubleshooting required.
520542	03	Communication System Fault CAN Communication Error	Troubleshooting required.
520543	04	Communication System Fault CAN Communication Error	Troubleshooting required.
520870	31	Instrument Cluster Control Unit Fault	ICC will not function. Troubleshooting required.
520871	31	Instrument Cluster Control Unit Fault	ICC will not function. Troubleshooting required.
520872	31	Instrument Cluster Control Unit Fault	ICC will not function. Troubleshooting required.
520873	31	Instrument Cluster Control Unit Fault	ICC will not function. Troubleshooting required.
520874	31	Instrument Cluster Control Unit Fault	ICC will not function. Troubleshooting required.
520875	31	Instrument Cluster Control Unit Fault	ICC will not function. Troubleshooting required.
520876	31	Instrument Cluster Control Unit Fault	ICC will not function. Troubleshooting required.
523899	03	HVAC System Circuit Fault	May experience poor engine performance. Troubleshooting required.
523899	04	HVAC System Circuit Fault	Air conditioning is off. Troubleshooting required.
523910	31		
524265	31	Instrument Cluster Control Unit Fault	ICC will not function. Troubleshooting required.

SB31882.000027E-19-31AUG18

Storage

Storing Safety

⚠ CAUTION: Avoid injury! Fuel vapors are explosive and flammable.

Engine exhaust fumes contain carbon monoxide and cause serious illness or death:

- **Run the engine only long enough to move the machine to or from storage.**
- **If a machine is stored before allowing it to cool, machine fires and structure fires can occur. Fires can occur if debris is not removed from around the engine and muffler, or if stored near combustible materials.**
- **Do not store vehicle with fuel in the tank inside a building where fumes reach an open flame or spark.**
- **Allow the engine to cool before storing the machine in any enclosure.**

MP47322.00F4680-19-06MAY15

Preparing Machine for Storage

1. Repair any worn or damaged parts. Replace parts if necessary. Tighten loose hardware.
2. Repair scratched or chipped metal surfaces to prevent rust.
3. Remove grass and debris from machine.
4. Wash the machine with low pressure water and apply wax to metal and plastic surfaces.
5. Run machine for five minutes to dry belts and pulleys.
6. Apply light coat of engine oil to pivot and wear points to prevent rust.
7. Lubricate grease points.
8. Check tire pressure.

MX00654.00000C8-19-24AUG13

Preparing Fuel and Engine For Storage

Fuel:

If you have been using "Stabilized Fuel," add stabilized fuel to tank until the tank is full.

NOTE: Filling the fuel tank reduces the amount of air in the fuel tank and helps reduce deterioration of fuel.

If you are not using "Stabilized Fuel:"

1. Park machine safely in a well-ventilated area. (See Parking Safely in the Safety section.)

NOTE: Try to anticipate the last time the machine will be used for the season so very little fuel is left in the fuel tank.

2. Turn on engine and allow to run until it runs out of fuel.
3. For machines equipped with an ignition key switch, turn the ignition key switch to the OFF position.

IMPORTANT: Avoid damage! Stale fuel can produce varnish and plug carburetor or injector components and affect engine performance.

- **Add fuel conditioner or stabilizer to fresh fuel before filling tank.**
4. Mix fresh fuel and fuel stabilizer in separate container. Follow stabilizer instructions for mixing.
 5. Fill fuel tank with stabilized fuel.
 6. Run engine for a few minutes to allow fuel mixture to circulate through carburetor on gas engine or fuel injectors on diesel engine.

Engine:

Engine storage procedure should be used when vehicle is not to be used for longer than 60 days.

1. Change engine oil and filter while engine is warm.
2. Service air filter if necessary.
3. Clean debris from engine air intake screen.
4. On gas engines:
 - Remove spark plugs. Put 30 mL (1 oz.) of clean engine oil in cylinders.
 - Install spark plugs, but do not connect spark plug wires.
 - Crank the engine 5 or 6 times to allow oil to be distributed.
5. Clean the engine and engine compartment.
6. Remove battery.
7. Clean the battery and battery posts. Check the electrolyte level, if your battery is not maintenance free.
8. Close fuel shut-off valve, if your machine is equipped.
9. Store the battery in a cool, dry place where it will not freeze.

NOTE: The stored battery should be recharged every 90 days.

10. Charge the battery.

Storage

IMPORTANT: Avoid damage! Prolonged exposure to sunlight could damage the hood surface. Store machine inside or use a cover if stored outside.

11. Store the vehicle in a dry, protected place. If vehicle is stored outside, put a waterproof cover over it.

MP47322,00F4682-19-30AUG18

Storage

Removing Machine From Storage

1. Check tire pressure.
2. Check engine oil level.
3. Check battery electrolyte level, if your battery is not maintenance free. Charge battery if necessary.
4. Install battery.
5. On gas engines: Check spark plug gap. Install and tighten plugs to specified torque.
6. Lubricate all grease points.
7. Open fuel shut-off valve, if your machine is equipped.
8. Be sure all shields and guards or deflectors are in place.

MX00654,00000C9-19-24AUG13

Specifications

Engine

Make Yanmar 3TNV70
Type Diesel
Displacement 854 cc
Cylinders 3
Oil Filter Spin On Filter
Air Cleaner Dual Element, Replaceable
Cooling Liquid

OUMX068,0000D1E-19-31JUL15

Drive Train and Travel Speeds

Type Continuously Variable Transmission (CVT) with Clutch Enclosure
Gear Ranges Forward HI and LO - Neutral - Reverse
Travel Speeds:
Forward HI 52 km/h (32 mph)
Forward LO 27 km/h (17 mph)
Reverse 32 km/h (20 mph)

SB31882,0000286-19-07AUG18

Electrical System

Type 12 Volt
Battery Size480 Cold Cranking Amps @ -18° C (0° F)
Alternator55 Amp

MX00654,000011D-19-06SEP13

Fuel System

Fuel Filter Replaceable Element
Fuel Diesel

MX00654,000011E-19-06SEP13

Steering and Brakes

Steering Rack and Pinion
Brakes Hydraulic Disc

OUMX068,000099C-19-09SEP14

Specifications

Tires

All tires can carry permissible axle loads.

NOTE: All tire load conditions are not to exceed Gross Vehicle Weight Rating (GVWR).

Front Tires

Terra Hawk AT	25x9-12
Front Axle Load < 621 kg (1370 lb)	97 kPa (14 psi)
Front Axle Load 621 - 764 kg (1370 - 1685 lb)	138 kPa (20 psi)
Maxxis Bighorn 2.0, Radial	27x9 R14
Front Axle Load < 687 kg (1515 lb)	97 kPa (14 psi)
Front Axle Load 687 - 839 kg (1515 - 1850 lb)	138 kPa (20 psi)

Rear Tires

Terra Hawk AT	25x11-12
Rear Axle Load < 746 kg (1645 lb)	97 kPa (14 psi)
Rear Axle Load 746 - 1064 kg (1645 - 2347 lb)	179 kPa (26 psi)
Maxxis Bighorn 2.0, Radial	27x11-R14
Rear Axle Load < 843 kg (1860 lb)	97 kPa (14 psi)
Rear Axle Load 843 - 1064 kg (1860 - 2347 lb)	152 kPa (22 psi)

SB31882,000027F-19-17SEP18

Capacities

Fuel Tank	42.4 L (11.2 gal)
Crankcase (with filter)	1.7 L (1.8 qt)
4WD Front Differential	0.66 L (22.3 oz)
Transaxle	4.1 L (4.3 qt)

Specifications

Cooling System (including recovery tank)	4.9 L (5.2 qt)
Brake	364 mL (12.3 oz)
Park Brake	50 mL (1.7 oz)

MX10673.0000061-19-02SEP17

Fluorinated Greenhouse Gas

Air Conditioner System contains Fluorinated Greenhouse Gas (F-Gas)	
Type of F-Gas:	R-134a
F-Gas Mass (kg):	1.09 kg (2.4 lb)
CO ₂ Equivalent (tonnes):	1.56 t
Global Warming Potential (GWP):	1430

MK71445.0000034-19-31AUG17

Dimensions

Width (with cab)	1.8 m (70 in.)
Length (with bumper)	3.4 m (132 in.)
Height (with OPS)	2.0 m (78 in.)
Ground Clearance	28 cm (11.0 in.)

MX10673.0000062-19-02SEP17

Weights

Weight XUV865E (Empty vehicle with full fluids)	880 kg (1936 lb)
Weight XUV865M (Empty vehicle with full fluids)	884 kg (1944 lb)
Weight XUV865M w/cab (Empty vehicle with full fluids)	982 kg (2160 lb)
Weight XUV865M w/ cab, HVAC (Empty vehicle with full fluids)	1043 kg (2293 lb)
Weight XUV865R (Empty vehicle with full fluids)	1071 kg (2356 lb)
Gross Vehicle Weight Rating (GVWR)	1542 kg (3400 lb)
Payload Capacity XUV865E	664 kg (1464 lb)
Payload Capacity XUV865M	660 kg (1456 lb)
Payload Capacity XUV865M w/cab	562 kg (1240 lb)
Payload Capacity XUV865M w/ cab, HVAC	502 kg (1107 lb)
Payload Capacity XUV865R	473 kg (1044 lb)
Cargo Box Capacity (Not to exceed GVWR)	454 kg (1000 lb)
Towing Capacity (Not to exceed GVWR)	907kg (2000 lb)
Maximum Trailer Tongue Weight	91 kg (200 lb)
Maximum Front Axle Load	841 kg (1850 lb)
Maximum Rear Axle Load	1067 kg (2347 lb)

MX10673.0000063-19-12SEP17

Specifications

Recommended Lubricants

Engine Oil	John Deere PLUS-50™
	John Deere Torq-Gard Supreme™
Grease	John Deere Multi-Purpose HD Lithium Complex Grease
	Grease-Gard™ Premium Plus
Transmission Oil (Transaxle)	John Deere HY-GARD™ (JDM J20C)
Transmission Oil (4WD Front Differential)	John Deere HY-GARD™ (JDM J20C)

(Specifications and design subject to change without notice.)

OUMX068,00009B0-19-11SEP14

Warranty

Product Warranty

John Deere offers a standard warranty on new John Deere products. For a copy of the product warranty statement or for details on the warranty terms and conditions for products purchased in the United States and Canada, please contact your local John Deere Dealer or utilize the following resources:

United States

Website:

http://www.deere.com/en_US/services_and_support/warranty/warranty.page

Toll Free: 1-800-537-8233

Dealer Locator:

<http://dealerlocator.deere.com/servlet/country=US>

Canada

Website (English):

http://www.deere.ca/en_CA/services_and_support/service_plans_warranties/service_plans_warranties.page

Website (French):

http://fr.deere.ca/en_CA/services_and_support/service_plans_warranties/service_plans_warranties.page

Toll Free: 1-800-537-8233

Dealer Locator:

<http://dealerlocator.deere.com/servlet/country=CA>

Emission-related warranties are included in this Operator's Manual, and applicable if required by law or regulation.

For products purchased in a country other than the United States or Canada, please contact your local John Deere dealer for assistance.

MP47322.00F4690-19-09JUL15

EMISSION-RELATED WARRANTY STATEMENT OFF-ROAD UTILITY VEHICLE OVER 25 MPH

YOUR WARRANTY RIGHTS AND OBLIGATIONS

To determine if the John Deere off-road utility vehicle qualifies for the additional warranties set forth below, look for the "Vehicle Emission Control Information" label located on the vehicle. If the vehicle is operated in the United States or Canada and the "Vehicle Emissions Control Information" label states: "This vehicle meets U. S. EPA exhaust and evap regulations" refer to the "United States and Canada Emission-Related Warranty Statement." If the vehicle is operated in California, and the label states: "This vehicle meets California

regulations" also refer to the "California Evaporative Emissions Control System Warranty Statement."

UNITED STATES AND CANADA EMISSIONS-RELATED WARRANTY STATEMENT

Warranties stated on this certificate refer only to emissions-related parts and components of your engine. The complete engine warranty, less emissions-related parts and components, is provided separately. If you have a question about your emissions warranty coverage, how to make an emissions warranty claim or how to make arrangements for emissions-related authorized repairs, you should contact your John Deere Turf and Utility retailer, or the John Deere Customer Contact Center at 1-800-537-8233, or email John Deere from https://www.deere.com/en_US/services_and_support/technology-solutions/stellarsupport/answer-center/turf-answer-center.page

JOHN DEERE'S WARRANTY RESPONSIBILITY:

John Deere warrants to the ultimate purchaser and each subsequent purchaser that this off-road utility vehicle engine and equipment, including all parts of its emission-control system was designed, built and equipped so as to conform at the time of sale with 40 CFR Part 1051 and Section 213 of the Clean Air Act and is free from defects in materials and workmanship that would cause the engine to fail to conform with applicable US EPA regulations. The emission-related warranty period for vehicles without an odometer is 30 months from when the engine is placed into service. The emission-related warranty period for vehicles with an odometer is 30 months from when the engine is placed into service, 500 hours or 5000 kilometers, whichever comes first, after the engine and equipment is delivered to the ultimate purchaser.

Where a warrantable condition exists, John Deere will repair or replace, as it elects, any part or component with a defect in materials or workmanship that would increase the engine's emissions of any regulated pollutant within the stated warranty period at no cost to you, including expenses related to diagnosing and repairing or replacing emission-related parts. Coverage under this warranty includes, but is not limited to, the parts listed below (the emissions control system parts) to the extent these parts were present on the engine and equipment purchased. Warranty coverage is subject to the limitations and exclusions set forth herein. Emission-related components include engine parts developed to control emissions related to the following:

I. For exhaust emissions, emission-related components include any engine parts related to the following systems:

1. Air-induction system.
2. Fuel system.
3. Ignition system.
4. Exhaust gas recirculation systems.

Warranty

II. The following parts are also considered emission-related components for exhaust emissions:

1. Aftertreatment devices.
2. Crankcase ventilation valves.
3. Sensors.
4. Electronic control units.

III. The following parts are considered emission-related components for evaporative emissions:

1. Fuel Tank.
2. Fuel Cap.
3. Fuel Line.
4. Fuel Line Fittings.
5. Clamps*.
6. Pressure Relief Valves*.
7. Control Valves*.
8. Control Solenoids*.
9. Electronic Controls*.
10. Vacuum Control Diaphragms*.
11. Control Cables*.
12. Control Linkages*.
13. Purge Valves.
14. Vapor Hoses.
15. Liquid/Vapor Separator.
16. Carbon Canister.
17. Canister Mounting Brackets.
18. Carburetor Purge Port Connector..
19. Carburetor bowl gaskets

***As related to the evaporative emission control system.**

EMISSION-RELATED WARRANTY EXCLUSIONS:

John Deere may deny emission-related warranty claims for malfunctions or failures caused by:

- Non-performance of maintenance requirements listed in the Operator's Manual.
- The use of the engine / equipment in a manner for which it was not designed.
- Abuse, neglect, improper maintenance or unapproved modifications or alterations.
- Accidents for which John Deere does not have responsibility or by acts of God.

The off-road utility vehicle engine is designed to operate on those fuels specified in the Fuels, Lubricants and Coolants section in the Operators Manual. Use of any other fuel can harm the emissions control system of the engine / equipment and is not approved for use.

To the extent permitted by law John Deere is not liable for damage to other engine components caused by a

failure of an emission-related part, unless otherwise covered by standard warranty, nor shall it be liable for travel or mileage expenses on emissions warranty service calls.

Limited Liability

a. The liability of John Deere under this Emission-Related Warranty is limited solely to the remedying of defects in materials or workmanship. This warranty does not cover inconvenience or loss of use of the off-road utility vehicle engine and equipment or transportation of the equipment to or from the John Deere Turf and Utility retailer. John Deere shall not be liable for any other expense, loss, or damage, whether direct, incidental, consequential or exemplary arising in connection with the sale or use of or inability to use the off-road utility vehicle engine and equipment for any other purpose.

b. THIS WARRANTY AND ANY OTHER APPLICABLE JOHN DEERE WARRANTIES ARE EXPRESSLY IN LIEU OF ANY OTHER WARRANTIES, EXPRESS OR IMPLIED, INCLUDING ANY WARRANTY OF MERCHANTABILITY OR FITNESS FOR A PARTICULAR PURPOSE. REMEDIES UNDER THIS WARRANTY ARE LIMITED TO THE PROVISIONS OF MATERIAL AND SERVICES AS SPECIFIED HEREIN. WHERE PERMITTED BY LAW, NEITHER JOHN DEERE NOR ANY AUTHORIZED JOHN DEERE ENGINE DISTRIBUTOR, DEALER, OR REPAIR FACILITY OR ANY COMPANY AFFILIATED WITH JOHN DEERE WILL BE LIABLE FOR INCIDENTAL OR CONSEQUENTIAL DAMAGES.

c. No dealer is authorized to modify this John Deere and Federal Emission-Related Warranty.

CALIFORNIA EVAPORATIVE EMISSIONS CONTROL WARRANTY STATEMENT

To determine if the John Deere off-highway recreational vehicle qualifies for the additional warranties set forth below, look for the "Vehicle Emission Control Information" label located on the vehicle. If the vehicle is operated in the United States or Canada and the "Vehicle Emissions Control Information" label states: "This vehicle meets U.S. EPA exhaust and evap regulations" refer to the "United States and Canada Emission-Related Warranty Statement." If the vehicle is operated in California, and the label states: "This vehicle meets California regulations" also refer to the "California Evaporative Emissions Control System Warranty Statement."

YOUR WARRANTY RIGHTS AND OBLIGATIONS

The California Air Resources Board and John Deere are pleased to explain the evaporative emissions control system warranty on your 2018 or 2019 off-highway recreational vehicle. In California, new off-highway recreational vehicles must be designed, built, and equipped to meet the State's stringent anti-smog standards. John Deere must warrant the evaporative emissions control system on your off-highway recreational vehicle for the periods of time listed below

Warranty

provided there has been no abuse, neglect, improper maintenance, or unapproved modification of your off-highway recreational vehicle.

Your evaporative emissions control system may include parts such as the carburetor or fuel-injection system, fuel tank, fuel hoses, carbon canister, and engine computer. Also included may be hoses, belts, connectors and other evaporative emissions-related assemblies. Where a warrantable condition exists, John Deere will repair your off-highway recreational vehicle at no cost to you including diagnosis, parts and labor.

JOHN DEERE'S WARRANTY COVERAGE:

For 2018 and later model year off-highway recreational vehicles, the warranty period for this off-highway recreational vehicle is 30 months, or 2500 miles, or 250 hours, whichever comes first, except for "high-priced" warranty parts [for example: fuel tanks, fuel injectors (if installed), and carburetors (if installed)], which are covered for 60 months, or 5000 miles, or 500 hours, whichever comes first, after the engine and equipment is delivered to the ultimate purchaser.

The following parts are considered emission-related components for evaporative emissions:

1. Fuel Tank**
2. Fuel Cap
3. Fuel Line
4. Fuel Line Fittings
5. Clamps*
6. Pressure Relief Valves*
7. Control Valves*
8. Control Solenoids*
9. Electronic Controls*
10. Vacuum Control Diaphragms*
11. Control Cables*
12. Control Linkages*
13. Purge Valves
14. Vapor Hoses
15. Liquid/Vapor Separator
16. Carbon Canister
17. Canister Mounting Brackets
18. Carburetor Purge Port Connector
19. Carburetor bowl gaskets
20. Carburetor**
21. Fuel Injector**

***As related to the evaporative emission control system.**

****Denotes "high-priced" warranty parts.**

If any evaporative emissions-related part on your off-highway recreational vehicle is defective the part will be repaired or replaced by John Deere.

OWNER'S WARRANTY RESPONSIBILITIES:

As the off-highway recreational vehicle owner you are responsible for the performance of the required maintenance listed in your owner's manual. John Deere recommends that you retain all receipts covering maintenance on your off-highway recreational vehicle, but John Deere cannot deny warranty solely for the lack of receipts or for your failure to ensure the performance of a scheduled maintenance.

As an owner you are responsible for presenting your off-highway recreational vehicle to a John Deere dealer as soon as a problem exists. The warranty repairs should be completed in a reasonable amount of time, not to exceed 30 days.

As an off-highway recreational vehicle owner, you should also be aware that John Deere may deny you warranty coverage if your off-highway recreational vehicle or a part has failed due to abuse, neglect, improper maintenance or unapproved modifications.

If you have any questions regarding your warranty rights and responsibilities, you should contact a John Deere Turf and Utility retailer, or the John Deere Customer Contact Center at 1-800-537-8233, or email John Deere from https://www.deere.com/en_US/services_and_support/technology-solutions/stellarsupport/answer-center/turf-answer-center.page or the California Air Resources Board at 9528 Telstar Avenue, El Monte, CA 91731.

ADDITIONAL EVAPORATIVE EMISSIONS CONTROL SYSTEM WARRANTY INFORMATION:

Subject to the conditions and exclusions of the Limited Liability Section below, the warranty on emissions-related parts must function as follows:

(1) Any warranted part which is not scheduled for replacement as part of maintenance in the written instructions (see the "Service Intervals" section of the Operator's manual) must be warranted for the warranty period defined in the Warranty Coverage section above. If any such part fails during the warranty period, it must be repaired or replaced by John Deere according to part 4 of this section. Any such part repaired or replaced under warranty must be fully warranted.

(2) Any warranted part which is scheduled only for regular inspection in the written instructions (see the "Service Intervals" section of the Operator's manual) must be warranted for the Warranty Coverage section above. A statement in such written instructions to the effect of "repair or replace as necessary" must not reduce the period of warranty coverage. Any such part repaired or replaced under warranty must be warranted for the remaining warranty period.

(3) Any warranted part which is scheduled for replacement as part of maintenance in the written instructions (see the "Service Intervals" section of the Operator's manual) must be warranted for the period of time prior to the first scheduled replacement point for

Warranty

that part. If the part fails before the first scheduled replacement point, the part must be repaired or replaced by John Deere according to part 4 of this section. Any such part repaired or replaced under warranty must be warranted for the remainder of the period prior to the first scheduled replacement point for the part.

(4) Repair or replacement of any warranted part under this warranty must be performed at no charge to the off-highway recreational vehicle owner, at a warranty station, except in the case of a temporary repair when a warranted part or a warranty station is not reasonably available to the off-highway recreational vehicle owner. In the event a temporary repair is permitted under this warranty, repairs may be performed at any available service establishment, or by the owner, using any replacement part. John Deere must reimburse the owner for his or her expenses including diagnostic charges for such temporary repair or replacement, not to exceed John Deere's suggested retail price for all warranted parts replaced and labor charges based on John Deere's recommended time allowance for the warranty repair and the geographically appropriate hourly labor rate.

(5) Warranty services or repairs must be provided at all John Deere dealerships.

(6) The off-highway recreational vehicle owner must not be charged for diagnostic labor which leads to the determination that a warranted part is, in fact, defective, provided that such diagnostic work is performed at a warranty station.

(7) John Deere is liable for damages to other vehicle components proximately caused by a failure, under warranty, of any warranted part.

(8) Throughout the off-highway recreational vehicle's warranty period defined in the Warranty Coverage section above, John Deere must maintain a supply of warranted parts sufficient to meet the expected demand for such parts. The lack of availability of such parts or the incompleteness of repairs within a reasonable time period, not to exceed 30 days from the time the off-highway recreational vehicle is initially presented to the warranty station for repair, will qualify the need for a temporary repair for purposes of part 4 of this section.

(9) Any replacement part designated by John Deere may be used in warranty repairs provided without charge to the off-highway recreational vehicle owner. Such use will not reduce the warranty obligations of John Deere, except that John Deere will not be liable under this Warranty for repair or replacement of any replacement part which is not a warranted part (except as provided under part 7 of this section).

(10) Any add-on or modified part exempted by the Air Resources Board from the prohibitions of section 27156 of the California Vehicle Code may be used on an off-highway recreational vehicle. Such use, in and of itself, will not be grounds for disallowing a warranty claim made under this Warranty. John Deere is not liable

under this Warranty to warrant failures of warranted parts caused by the use of an add-on or modified part(s) unless such part(s) are also warranted.

Limited Liability

a. The liability of John Deere under this Evaporative Emissions Control Warranty is limited solely to the remedying of defects in materials or workmanship. This warranty does not cover inconvenience or loss of use of the off-highway recreational vehicle engine and equipment or transportation of the equipment to or from the John Deere Turf and Utility retailer. John Deere shall not be liable for any other expense, loss, or damage, whether direct, incidental, consequential or exemplary arising in connection with the sale or use of or inability to use the off-road utility vehicle engine and equipment for any other purpose.

b. THIS WARRANTY AND ANY OTHER APPLICABLE JOHN DEERE WARRANTIES ARE EXPRESSLY IN LIEU OF ANY OTHER WARRANTIES, EXPRESS OR IMPLIED, INCLUDING ANY WARRANTY OF MERCHANTABILITY OR FITNESS FOR A PARTICULAR PURPOSE. REMEDIES UNDER THIS WARRANTY ARE LIMITED TO THE PROVISIONS OF MATERIAL AND SERVICES AS SPECIFIED HEREIN. WHERE PERMITTED BY LAW, NEITHER JOHN DEERE NOR ANY AUTHORIZED JOHN DEERE ENGINE DISTRIBUTOR, DEALER, OR REPAIR FACILITY OR ANY COMPANY AFFILIATED WITH JOHN DEERE WILL BE LIABLE FOR INCIDENTAL OR CONSEQUENTIAL DAMAGES.

c. No dealer is authorized to modify this John Deere and California Evaporative Emissions Control Warranty.

TC00531.00000EE-19-30AUG18

Tire Warranty

John Deere warranty applies for tires available through the John Deere parts system. For tires not available through the John Deere parts system, the tire manufacturer's warranty applicable to your machine may not apply outside the U.S. (See your John Deere dealer for specific information.)

MX00654.0000314-19-21AUG14

Limited Battery Warranty For Factory Installed Batteries

NOTE: Applicable in North America only. For complete machine warranty, reference a copy of the John Deere warranty statement. Contact your John Deere dealer to obtain a copy.

TO SECURE WARRANTY SERVICE

The purchaser must request warranty service from a John Deere dealer authorized to sell John Deere

Warranty

batteries, and present the battery to the dealer with the top cover plate codes intact.

FREE REPLACEMENT PERIOD

Any new battery which becomes unserviceable (not merely discharged) due to defects in material or workmanship within the FREE REPLACEMENT PERIOD will be replaced free of charge. Installation costs will be covered by warranty if the unserviceable battery was installed by a John Deere factory or dealer and the replacement battery is installed by a John Deere dealer.

PRO RATA ADJUSTMENT (batteries with letter code identification only)

Any new battery which becomes unserviceable (not merely discharged) due to defects in material or workmanship within the Pro Rata Warranty Period will be replaced upon payment of the battery's current list price less a pro rata credit for unused months of service. The applicable adjustment period is determined from the Warranty Code printed at the top of the battery and table below. Installation costs are not covered after the battery warranty period has ended.

THIS WARRANTY DOES NOT COVER

- A. Breakage of the container, cover, or terminals.
- B. Depreciation or damage caused by lack of reasonable and necessary maintenance or by improper maintenance.
- C. Transportation, mailing, or service call charges for warranty service.
- D. Batteries that are merely discharged.

LIMITATION OF IMPLIED WARRANTIES AND PURCHASER'S REMEDIES

To the extent permitted by law, neither John Deere nor any company affiliated with it makes any warranties, representations, or promises as to the quality, performance or freedom from defect of the products covered by this warranty. IMPLIED WARRANTIES OF MERCHANTABILITY AND FITNESS FOR A PARTICULAR PURPOSE, TO THE EXTENT APPLICABLE, SHALL BE LIMITED IN DURATION TO THE APPLICABLE ADJUSTMENT PERIOD SET FORTH HERE. THE PURCHASER'S ONLY REMEDIES IN CONNECTION WITH THE BREACH OR PERFORMANCE OF ANY WARRANTY ON JOHN DEERE BATTERIES ARE THOSE SET FORTH HERE. IN NO EVENT WILL THE DEALER, JOHN DEERE OR ANY COMPANY AFFILIATED WITH JOHN DEERE BE LIABLE FOR INCIDENTAL OR CONSEQUENTIAL DAMAGES. (Note: Some states do not allow limitations on how long an implied warranty lasts or the exclusion or limitation of incidental or consequential damages. So these limitations and exclusions may not apply to you.) This warranty gives you specific legal rights, and you may also have some rights which vary from state to state.

NO DEALER WARRANTY

The selling dealer makes no warranty of its own and the dealer has no authority to make any representation or promise on behalf of John Deere, or to modify the terms or limitations of this warranty in any way.

WARRANTY TERMS TABLE

NOTE: If your battery is not labeled with a warranty code, it is a warranty code 6.

Warranty Code	Free Replacement Period	Pro Rata Warranty Period
A	90 Days	40 Months
B	90 Days	36 Months
C	90 Days	24 Months
D	12 Months	48 Months
E	90 Days	12 Months
F	90 Days	60 Months
G	12 Months	60 Months
H	12 Months	60 Months
6	6 Months	0 Months
12	12 Months	0 Months
18	18 Months	0 Months

OUMX068,0000504-19-10MAY17

Warranty

John Deere Quality Statement

John Deere Quality

John Deere equipment is more than just a purchase, it's an investment in quality. That quality goes beyond our equipment to your John Deere dealer's parts and service support. This support is needed to keep you a satisfied customer.

That's why John Deere has initiated a process to handle your questions or problems, should they arise. The following three steps will help guide you through the process.

Step 1

Refer to your operator's manual

- A. It has many illustrations and detailed information on the safe and proper operation of your equipment.
- B. It gives troubleshooting procedures, and specification information.
- C. It gives ordering information for parts catalogs, service and technical manuals.
- D. If your questions are not answered in the operator's manual, then go to Step 2.

Step 2

Contact your dealer

- A. Your John Deere dealer has the responsibility, authority, and ability to answer questions, resolve problems, and fulfill your parts and service needs.
- B. First, discuss your questions or problems with your dealer's trained parts and service staff.
- C. If the parts and service people are unable to resolve your problem, see the dealership manager or owner.
- D. If your questions or problems are not resolved by the dealer, then go to Step 3.

Step 3

Contact John Deere

- A. Your John Deere dealer is the most efficient source in addressing any concern, but if you are not able to resolve your problem after checking your operator's manual and contacting your dealer, contact John Deere for assistance.
- B. For prompt, effective service, please have the following ready before you call:
 - The name of the dealer with whom you've been working.
 - Your equipment model number.
 - Number of hours on machine (if applicable).
 - Your serial number which you recorded on the inside front cover of this manual.
 - If the problem is with an attachment, your attachment identification number.

C. Then call 1-800-537-8233 (United States and Canada) and our advisor will work with your dealer to investigate your concern. If you are outside the United States and Canada, visit the following website:

http://www.deere.com/globalhome/deerecom/global_home.page?CC=true

Select your country and then click on the Contact Us link.

SP66632.00043A7-19-10MAY17

Index

A		F	
Accessory Outlet, Using	36	Filter, changing engine oil	53
Adjustment, Altitude	52	Fluid, Brake	74
Air cleaner element, servicing	54	Fluorinated greenhouse gas, specifications	103
Air intake, checking hoses and clamps	55	Four Wheel Drive, Using	39
Alarm, Backup	48	Front Blade Switch, Using	36
Alternator Belt, Inspecting	63	Front Differential Oil, 4WD	66
B		Fuel	
Battery and Terminals, Cleaning	78	Biodiesel	85
Battery, Checking the	77	Diesel	85
Battery, Removing and Installing	77	Fuel Safety	22
Battery, service safely	77	Fuel Storage	98
Battery, Using Booster	79	Fuel System, Bleeding	56
Bench seat, using	27, 28	Fuel Tank, Filling	86
Biodiesel fuel	85	Fuse Filaments, Checking	90
Brakes		Fuses, replacing	80
Brake fluid, checking	74	G	
Brake lines, checking	75	Grease	51
Brake pads, checking	74	H	
Brakes, Troubleshooting	95, 96	Hand holds, using	28
Bushings, Tailgate, Replacing	90	Hazard Lights, Using	36
C		Headlight, replacing	79
Cab air filter, replacing	87	Headlights, Using	32
Cargo Box, Emptying	44	Hitch, Front Receiver	48
Cargo Box, Loading	43	Hood, opening and closing	89
Cargo Box, Troubleshooting	95	HVAC Belt, Inspecting	64
Cargo Box, Using	39	HVAC controls, using	36
Chains, Tire, Using	45	I	
Cleaning	92	Ignition Key Switch, Using	32
Clutch, Enclosure, Cleaning	71	Instrument cluster controller buttons, using	34
Controls, Operator	26	Instrument cluster controller, using	32
Coolant level, checking	58	L	
Coolant, Engine	62	Labels, safety with text	6
Cooling System, Service Safely	58	Labels, safety without text	11
Cooling System, Servicing	58	LED work lights, replacing	83
CV boots, checking	68	Lifting machine	88
D		Load capacity	42
Diesel fuel	85	Load Shedding	27
Doors or nets, using	27	Loads, Towing	44
Drive Belt, Checking	68	M	
Drive line, lubricating	51	Metal Surfaces, Repairing and Cleaning	92
Dust Unloading Valve, Cleaning	54	N	
E		Nets or doors, inspecting	89
Electrical, Troubleshooting	95	Nets or doors, using	27
Electronic display, use properly	22	O	
Emergency Stopping	38	Oil, checking engine	53
Engine compartment, cleaning	57	Oil, Transaxle	66
Engine, Starting the	37		
Engine, Stopping	38		
Engine, Troubleshooting	94		
Exit lighting, operation	35		

Index

Operating Checklist, Daily	27
Operator seat, adjusting	28

P

Park brake fluid, checking	75
Park Brake, Adjusting	76
Park Brake, Using	31
Parking Safely	16
Plastic And Painted Surfaces, Avoid Damage To	27
Plastic Surfaces, Cleaning	92
Power Steering, Using	38

R

Radiator Cooling Fins Cleaning (without HVAC)	57
Radiator hoses and clamps, checking	62
Record service dates	112
Replacement parts	2

S

Safety labels, with text	6
Safety labels, without text	11
Safety Start System, Testing	30
Safety Systems, Testing	30
Safety, tire	21
Seat Bench, using	27, 28
Operator, adjusting	28
Seat belt, inspecting	89
Seat belt, using	29
Seats, removing and installing	87
Sediment Bowl, Servicing	55
Service Information, Emissions	52
Service Safety	20
Spark arrestor, checking	64
Spark Arrestor, Using	16
Storage areas, using	37
Storage, Preparing Machine for	98
Storage, Removing Machine from	100
Storing Safety	98
Suspension, standard shocks, adjusting	91

T

Tilt steering wheel, adjusting	31
Tires, Inflation	45
Toe-in, checking and adjusting	90
Traction Assist, Using	38
Transaxle, changing oil	67
Transaxle, Checking Oil	67
Transporting	46
Travel controls, using	31
Troubleshooting chart	94
Turn Signal Switch, Using	36

W

Warranty, product	105
Wheel Assembly, Removing and Installing	86
Windshield, maintenance	93

Notes
